

# DLP® LightCrafter™ Display 160CP Evaluation Module



## Description

The DLP® LightCrafter™ Display .16 nHD Evaluation Module (EVM) is designed to enable microcontroller (MCU) generated graphics display without the need of a video processor; opening new possibilities for affordable DLP free-form on-demand display implementations in industrial and personal electronic applications such as appliances, human machine interface, robotics, and toys. This EVM features [DLP160CP](#) chipset including [DLPC3421](#), .16 nHD (640x360) optical engine, and [MSPM0G3507](#) MCU for image generation out of the box.

## Features

- Small form factor (66mm x 56mm)
- First DLP display EVM capable of displaying MCU generated content
- Easily evaluate image display from Micro SD card
- MSPM0G MCU family compatible (ARM® SWD, UART supported)
- nHD (640x360) resolution
- 20lm out of the box

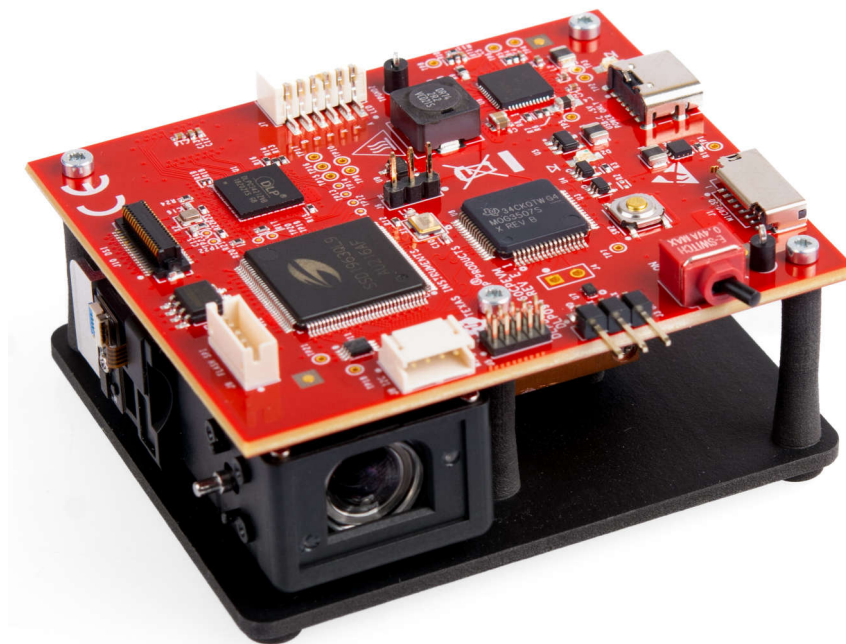

# 1 Evaluation Module Overview

## 1.1 Introduction

This user's guide presents an overview of the DLP® LightCrafter™ Display 160CP evaluation module (EVM) (DLPDLCR160CPEVM) and a general description of the main features and functions. The guide explains the first steps to get started, and shows a detailed description of onboard LEDs, connectors, and overall EVM assembly.

The EVM can be used as a standalone to display nHD (640x360) resolution graphics or images either generated by the DLPC3421 display controller or the MSPM0G3507 MCU (microcontroller). Images can also be added from a Micro-SD card through the MSPM0 MCU.

This guide provides the user with further information on how to successfully operate the EVM and get content projected on the wall.

## 1.2 Kit Contents

The DLPDLCR160CPEVM is shipped as a fully assembled unit. The only component required to power up the unit is a compatible power adapter (not included).

A 5V power adapter with a 1A minimum output and a USB-C connector is required.

## 1.3 DLPDLCR160CPEVM Subsystems

The DLP LightCrafter Display module consists of two subsystems:

- **Formatter Board:** includes the DLP chipset (DLPC3421 display controller and DLPA2005 PMIC/LED driver). The MSPM0G3507 MCU, SSD1963 video interface driver, and Micro-SD card connector are also included.
- **Light Engine:** includes optics, RGB LEDs, and DLP160CP DMD displaying 640 × 360 pixels (nHD) on screen. See light engine subsystem description in the table below.

**Table 1-1. EVM LED Currents and ANSI Lumens**

EVM Configuration	LED Currents (A) (Typ)			ANSI Lumens (Typ)
	Red	Green	Blue	
Default LED Current	0.20	0.25	0.25	20
Max LED Current	0.30	0.40	0.40	32

The DLPDLCR160CPEVM is designed to operate at a maximum ambient temperature of 30°C. A block diagram of the DLPDLCR160CPEVM is shown in [Figure 1-1](#).

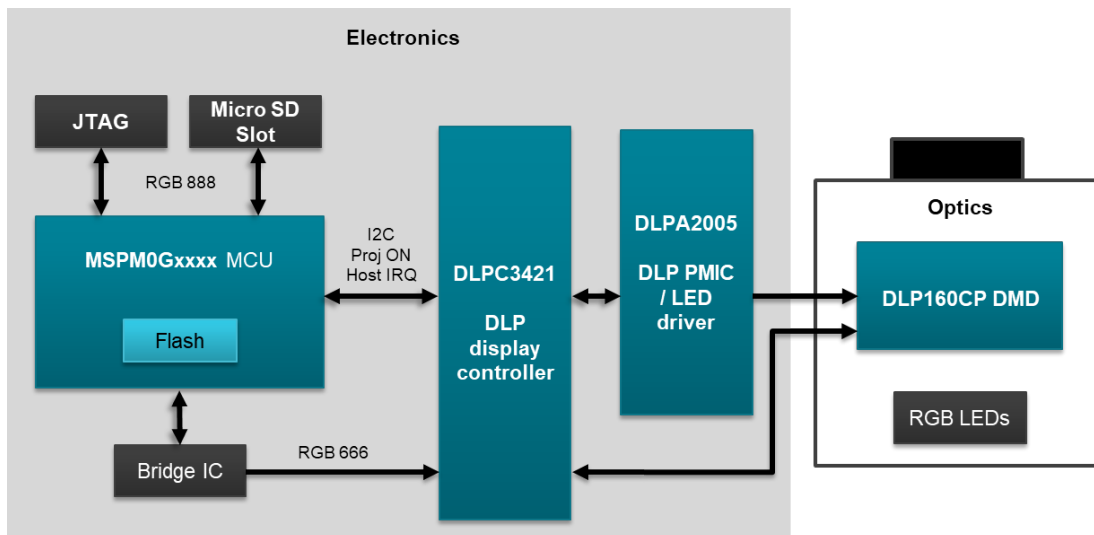

**Figure 1-1. DLPDLCR160CPEVM Block Diagram**

## 1.4 Device Information

- **DLPC3421** (Figure 2-1): display controller controls the DLPA2005 (Figure 2-1) PMIC/RGB illumination driver and the DLP160CP DMD (digital micromirror device).
- **DLP160CP** DMD is assembled with an ELEPN optical module using SFM-03X-CG and SFM-03X-RAB LEDs from Luminus with a brightness of 20L out of the box (the module is capable to deliver 50L, but requires additional thermal designs for proper operation).
- **MSPM0G3507** (Figure 2-1): MCU provides control application, nHD image generation through the SSD1963 (Figure 2-1), and UART (Universal Asynchronous Receiver/ Transmitter) (Figure 2-1) communication programmable capabilities. The MCU can be programmed using ARM® SWD (Serial Wire Debug) interface through the connector J5 (Figure 2-1).
- **SSD1963** (Bridge IC) video interface driver gets 8080 commands from the MCU and outputs RGB666 format data parallel interface signals to the DLPC3421 DLP display controller.
- **DSI input** (Figure 2-1): to the DLPC3421 controller is provided through an external interface connector. Video can be input through an external interface connector over the DSI interface. Please refer to the [DLPDLCR160CPEVM Software Programers Guide](#) and the [TI E2E®](#) community forums for additional support.
- **Power ON switch** (Figure 2-1) is used to gently power up and power down the DLP display system.
- **Programmable push button** (Figure 2-1) is used to provide user input controlled by the MCU.
- **MicroSD card slot** (Figure 2-1) is provided to add custom images controlled by the MCU (MicroSD card not included).
- **USB Type-C power supply interface** (Figure 2-1) is used to power the EVM unit (USB Type-C cable and power supply not included).

This DLP chipset is combined with illumination, projection optics, and RGB LEDs to create a projector that offers brightness of approximately 20 lumens out of the box for image or informational video display in a very small volume form factor.

**The DLPDLCR160CPEVM is not a production design, and is intended for evaluation only.**

## 2 Hardware

### 2.1 EVM Images

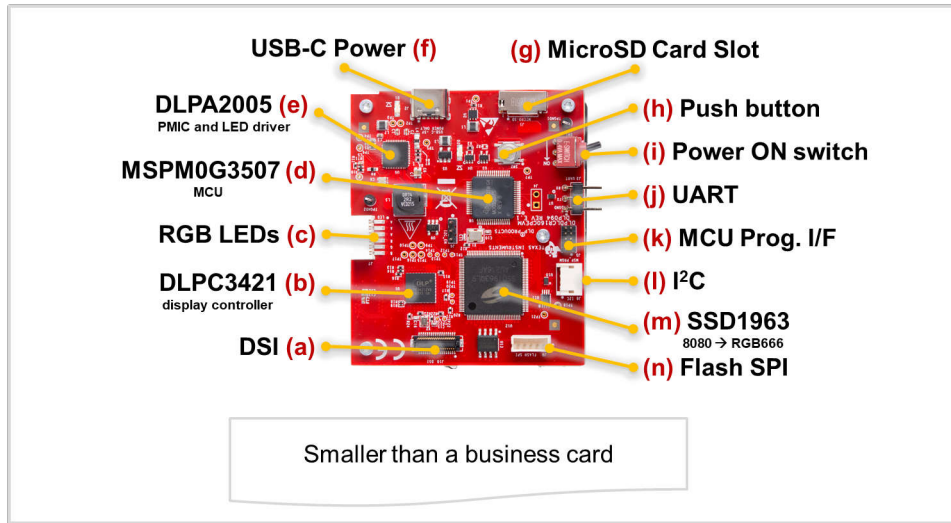



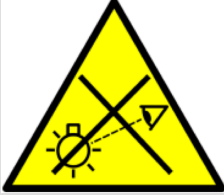

Figure 2-1. DLPDLCR160CPEVM Unit (top view)



Figure 2-2. DLPDLCR160CPEVM Unit (perspective view)

## 2.2 Safety Instructions





### Cautions and Warnings

	<p><b>WARNING</b></p> <p>Observe handling precautions. Electrostatic sensitive devices.</p>
	<p><b>CAUTION</b></p> <p>Do not stare into operating LED.</p>
	<p><b>CAUTION</b></p> <p>Do not leave EVM powered when unattended.</p>
	<p><b>CAUTION</b></p> <p>Caution hot surface. Contact may cause burns. Do not touch.</p>

## 2.3 Setup

Use the following instructions to set up and run the DLPDLCR160CPEVM. A 5V power adapter with a 1A minimum output and a USB-C connector is required.

**Table 2-1. Steps to Use the EVM**

Step	Action	Comments
Power switch (SW1) at OFF position	Power switch (Figure 2-1), SW1, needs to be in the OFF position before power is turned ON to the board. Toggle lever to the OFF position, opposite direction of the arrow shown on the board.	TI does not recommend to pull out the power cable or turn off the input power while the EVM is running. The SW1 switch is also used to turn off the EVM before the input power is turned off.   OFF
Connect power supply	Connect a USB-C power supply supporting 5V at 1A.	<b>Note</b> <b>Do not use a multi-voltage output USB-C power adapter.</b>
LED D1 turns on	The green LED, D1, lights up to indicate the board is receiving power.	
Power switch (SW1) ON	<b>Power switch (SW1) to the ON position</b> in the direction of the arrow on the board.	 ON
LED D2 turns on	The green LED, D2, lights up to indicate the board is in operational mode.	The RGB LEDs in the Optical Engine (OE) are turned on.
Splash Screen	The EVM shows a DLP Logo as a quick power up splash screen for approximately 1 second.	
DLP logo animation	A DLP Logo animation using graphics generated by the MCU plays for approximately 5 seconds.	
Main menu	A user selectable main menu is displayed.	  A description for each menu can be found in <a href="#">Section 2.3.1</a> .
Change menu selection	Quick button (SW2) press to cycle through all the menus. Selected menu button changes to yellow to confirm menu selection change.	There are 4 main menu options: View images in SD card, View images in Flash, Smart home demo, and Reserved. Menu selections are explained below.
Confirm menu selection	Long (>2 sec) button (SW2) press to confirm the menu selection.	The user action results in a button press animation to confirm selection.

### 2.3.1 Main Menu

After initial powerup and demo display, the push-button switch, SW2, can be used to cycle through the following four main input/display selections. See [Table 2-2](#) for reference.

**Table 2-2. Main Input/Display Selections**

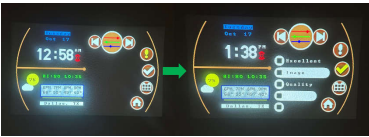
Option	Description	Instructions
MicroSD card	Display images from MicroSD card (not included).	Load content in the MicroSD card per <a href="#">Section 2.3.2</a> . Insert MicroSD card before selecting the menu. Images on the MicroSD are cycled on screen. Quick button (SW2) press after images start displaying causes the image display to abort and the screen display goes to the <i>Return to Menu</i> screen.
Images from Flash memory	Display pre-loaded images from display controller Flash memory.	Eight images stored in Flash memory shown individually. Quick button (SW2) press after images start displaying causes the image display to abort and the screen display goes to the <i>Return to Menu</i> screen.
Smart Home demo	Smart Home user interface demo. MCU generated images using media library.	Cycle through the <i>Smart Home</i> menus with a quick button press. Select each menu by long pressing the button. Select the <i>Home</i> icon to return the main menu. 
Reserved	Reserved space for future capabilities	

### 2.3.2 MicroSD Card Image

Images stored on a microSD card can be displayed by the EVM. Images must be stored on the card from a computer before inserting into J1, microSD card slot. Images are read out by the MSPM0G3507 MCU before being displayed. Each image is read out by the MCU and displayed until the new image is transferred. The images on the card are cycled through while in this mode.

#### MicroSD Card Requirements:

- Resolution: nHD (640 x 360) only
- Format: 24-bit RGB888 bitmap (.bmp) only
- Card Size: 32GB max. Larger card sizes must be formatted to FAT32 because exFAT is not supported.
- Number of images:
  - Four images max (limit in MSPM0G3507 Rev\_E15 code)
  - 20 images max (limit in MSPM0G3507 v1.24.3.2 code)
- The conf.txt file must be updated with any changes to the number of files, names of the files or the order that the files are to be displayed.

#### Note

For additional microSD card information, refer to [DLPDLR160CPEVM Software Programmer's Guide](#).

### 2.3.3 UART Communication

The UART interface is the main communication interface to the EVM through the J3 connector to the MSPM0G3507. The EVM commands and control can be sent by computer over a terminal interface, or the DLP EVM GUI program. Refer to the EVM MSPM0 Software and the DLPC3421 Software Programmer's Guide for command and programming info.

#### Note

After the GUI is used to communicate to the EVM, the menus displayed on screen are no longer functional. Cycle the SW1 switch OFF – ON to power cycle the display control and return functionality to the on-screen display menus.



## 3 Software

### 3.1 Programming Instructions

Use the following instructions to program the MSPM0 or the DLPC3421 flash memory.

#### 3.1.1 Programming MSPM0 MCU

The MSPM0G3507 MCU can be reprogrammed using either the Uniflash programming tool or the Code Composer Studio: Theia IDE.

Refer to the following documentation links for more detailed information:

- [MSPM0 MCUs Quick Reference Guide](#)
- [Code Composer Studio](#)
- [MSPM0 SDK](#)
- [UniFlash Guide for MSPM0](#)
- [UniFlash Quick Start Guide](#)

Refer to [Appendix](#) for more detailed EVM MSPM0 programming instructions.

#### 3.1.2 Programming DLPC3421 Display Controller Flash

The DLPC3421 Display Controller flash memory is pre-programmed with a control program binary file.

The EVM GUI can be used to generate a new binary file for programming based on selected options provided in the GUI. The new binary file can be programmed using the GUI over the UART interface.

Refer to the following documentation links for more detailed information:

- [DLPC3421 Software Programmer's Guide](#)



## 4 Appendix

### 1. Program MSPM0 Controller

- a. Items needed (\*not included with EVM)
  - i. XDS110 Debug Probe ([TMDSEMU110-U](#)) kit (with included cables & adapters) or [LP-XDS110](#) and 10-pin 2x5 Socket 1.27mm IDC (SWD) cable, purchased separately.\*
  - ii. TI UniFlash programming application.\*
  - iii. MSPM0 software or programming file.\*
  - iv. EVM UUT
  - v. 5V Power supply for EVM.\*
  - vi. Computer.\*
- b. If using the XDS110 Debug Probe, then connect to the computer with USB cable (USB-A to Micro USB cable included in kit).
- c. Connect the 20-pin debug cable to 20-pin debug header on the XDS110 Debug Probe.
- d. Connect the ARM® Cortex®-M 10-pin (CM10) adapter to the other end of the debug cable.
- e. Connect the CM10 adapter to J1 on the EVM (MSPM0 ARM® SWD connector).

---

#### Note

See example of LP-XDS110 and XDS110 Debug Probe Assembly in [Figure 4-1](#), [Figure 4-2](#), and [Figure 4-3](#).

- f. Connect power supply to board.
- g. Turn on power to board.

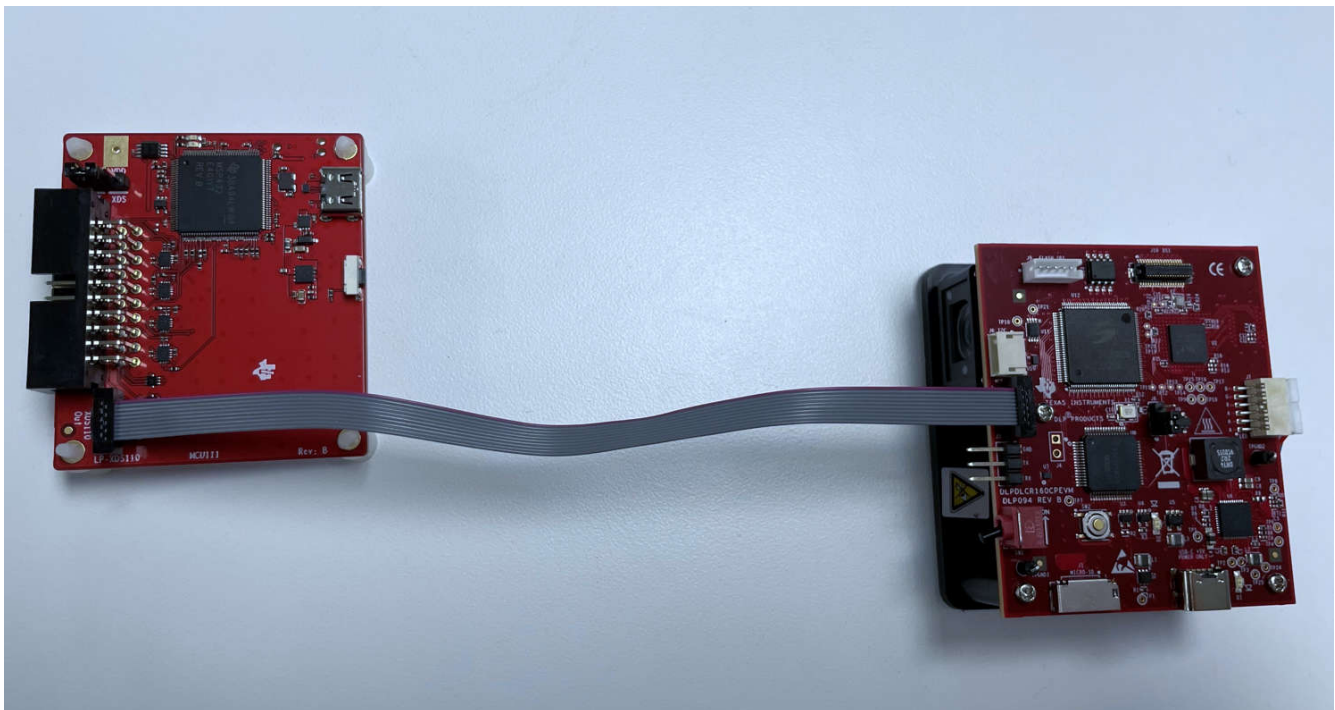

**Figure 4-1. LP-XDS110 Debug Probe and EVM**

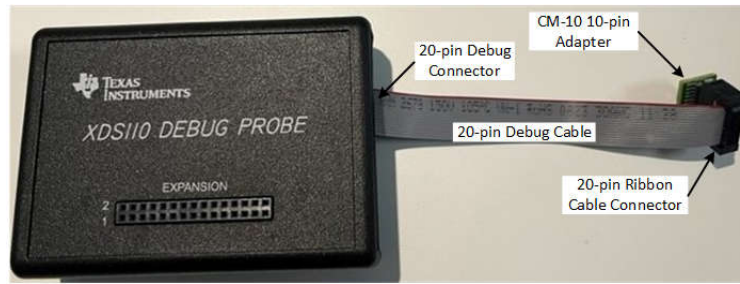

**Figure 4-2. XDS110 Debug Probe Assembly**



**Figure 4-3. XDS110 Debug Probe and Board Assembly**

2. UniFlash Programming
  - a. Download and install the TI UniFlash flash programming tool (version 8.4.0 or later) from TI.com at <https://www.ti.com/tool/UNIFLASH>.
  - b. Launch the UniFlash.exe

---

**Note**

The XDS110 firmware must be updated to v3.0.0.26 (or newer) to support the MSPM0 devices. The XDS firmware can be updated using the UNIFLASH programming tool.

- c. In the New Configuration tab, select the *MSPM0G3507* device, and *Texas Instruments XDS110 USB Debug Probe* connection:

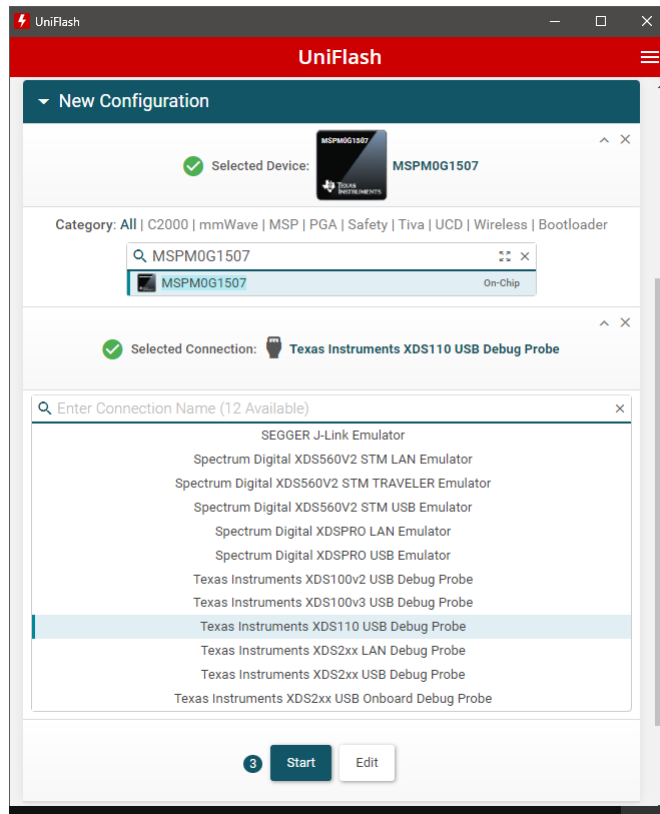

- d. Click the Start button.
- e. Browse for and select the *DLPDLCR160CPEVM\_RevE19.out* (or later) image.

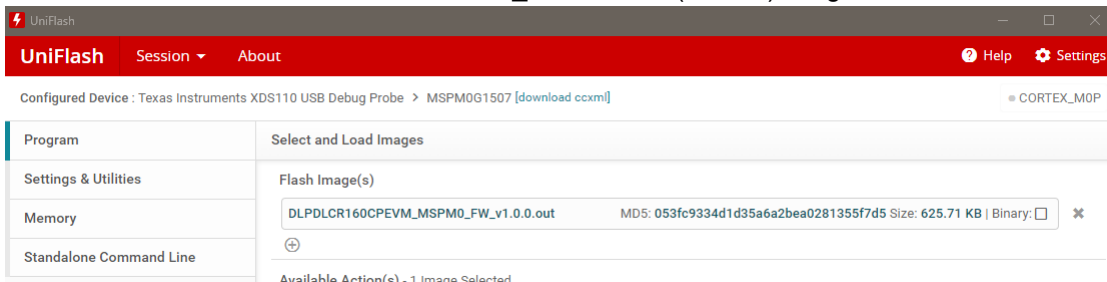

- f. Click the *Load image* button, and wait for the Load Program routine to complete.

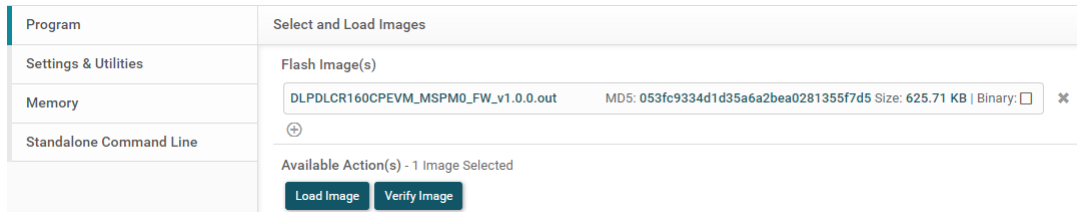

- g. Once the Load is completed successfully, click the *Verify Image* button.

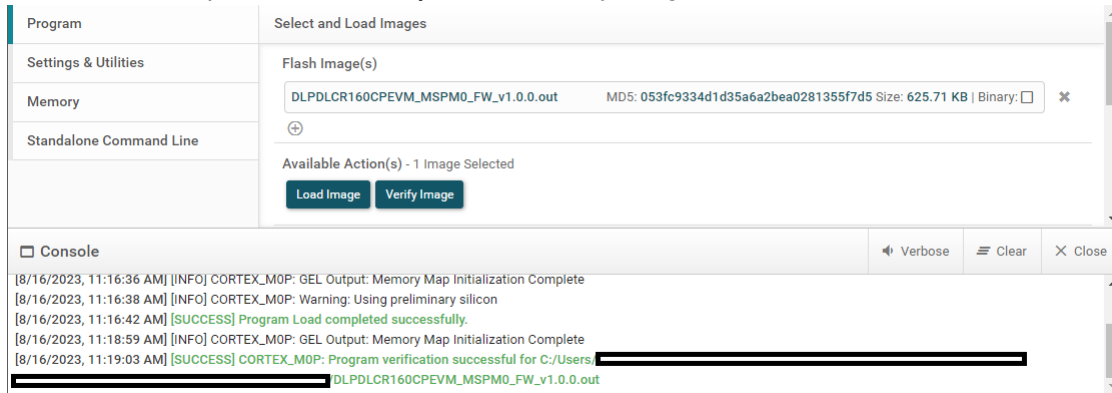

- h. If the verification is reported successful in the Console, then the flash programming of the MSPM0 is complete. If verification fails, then recheck setup and connections and retry programming.
- i. Procedure complete.
- j. Power down and disconnect cables.
- k. References:
- i. XDS110 Debug Probe User's Guide ([SPRUI94](#)).
  - ii. XDS110 web page, [www.ti.com/xds110](http://www.ti.com/xds110).

## 5 Additional Information

### 5.1 Notifications

In Compliance with Article 33 of the EU REACH regulation, we are notifying that this EVM includes a component containing at least one Substance of Very High Concern (SVHC) above 0.1%.

These uses by Texas Instruments do not exceed 1 ton per year. The SVHS's are:

**Table 5-1. REACH Compliance SVHC Substances**

Component Manufacturer	Component Type	Component Part #	SVHC Substance	SVHC CAS
Dailywell Electronics Co., Ltd.	Toggle Switch	2US1T1A1M6RES	Boron Oxide	1303-86-21
			Cadmium Oxide	1306-19-0
			Octamethylcyclotetrasiloxane	556-67-2
			Lead Oxide	1317-36-8
			Lead	7439-92-1
Chimei Corp.	Baseplate	MCH068	2,2',6,6'-tetrabromo-4, 4'-isopropylidenediphenol	79-94-7

### 5.2 Trademarks

LightCrafter™ is a trademark of Texas Instruments.

E2E™ is a trademark of Texas Instruments.

DLP® is a registered trademark of Texas Instruments.

ARM® and Cortex® are registered trademarks of Arm Limited.

All trademarks are the property of their respective owners.

## 6 Related Documentation

The following documents are applicable to the DLPDLCR160CPEVM and are available at ([www.ti.com](http://www.ti.com)).

- [DLPDLCR160CPEVM Software Programmer's Guide](#)
- [DLP160CP \(0.16 nHD\) DMD Data Sheet](#)
- [DLPA2005 Power Management and LED Driver IC Data Sheet](#)
- [DLPC3421 Display Controller Data Sheet](#)
- [DLPC3421 Software Programmer's Guide](#)

For additional documentation including Gerber files, schematics, BOM, and more, click on the links provided on the product page of the EVM on ti.com ([DLPDLCR160CPEVM](#)) under the technical documentation section.

For further assistance, see the [DLP Products and MEMS TI E2E™ community support forums](#).

## 7 Revision History

NOTE: Page numbers for previous revisions may differ from page numbers in the current version.

Changes from Revision * (November 2023) to Revision A (September 2024)	Page
• Added <i>EVM LED Currents and ANSI Lumens</i> table.....	2
• Updated <i>Device Information</i> section.....	3
• Updated <i>Setup</i> section.....	6
• Updated <i>Main Menu</i> section.....	7
• Updated <i>MicroSD Card Image</i> section.....	7
• Added <i>UART Communication</i> section.....	7
• Added <i>Notifications</i> section.....	13
• Updated <i>Related Documentation</i> section.....	13

## IMPORTANT NOTICE AND DISCLAIMER

TI PROVIDES TECHNICAL AND RELIABILITY DATA (INCLUDING DATA SHEETS), DESIGN RESOURCES (INCLUDING REFERENCE DESIGNS), APPLICATION OR OTHER DESIGN ADVICE, WEB TOOLS, SAFETY INFORMATION, AND OTHER RESOURCES "AS IS" AND WITH ALL FAULTS, AND DISCLAIMS ALL WARRANTIES, EXPRESS AND IMPLIED, INCLUDING WITHOUT LIMITATION ANY IMPLIED WARRANTIES OF MERCHANTABILITY, FITNESS FOR A PARTICULAR PURPOSE OR NON-INFRINGEMENT OF THIRD PARTY INTELLECTUAL PROPERTY RIGHTS.

These resources are intended for skilled developers designing with TI products. You are solely responsible for (1) selecting the appropriate TI products for your application, (2) designing, validating and testing your application, and (3) ensuring your application meets applicable standards, and any other safety, security, regulatory or other requirements.

These resources are subject to change without notice. TI grants you permission to use these resources only for development of an application that uses the TI products described in the resource. Other reproduction and display of these resources is prohibited. No license is granted to any other TI intellectual property right or to any third party intellectual property right. TI disclaims responsibility for, and you will fully indemnify TI and its representatives against, any claims, damages, costs, losses, and liabilities arising out of your use of these resources.

TI's products are provided subject to [TI's Terms of Sale](#) or other applicable terms available either on [ti.com](https://www.ti.com) or provided in conjunction with such TI products. TI's provision of these resources does not expand or otherwise alter TI's applicable warranties or warranty disclaimers for TI products.

TI objects to and rejects any additional or different terms you may have proposed.

Mailing Address: Texas Instruments, Post Office Box 655303, Dallas, Texas 75265  
Copyright © 2024, Texas Instruments Incorporated