

PCM4202EVM User's Guide

This document provides the information needed to set up and operate the PCM4202EVM evaluation module (EVM). For a more detailed description of the PCM4202, please refer to the product datasheet available from the Texas Instruments web site at <http://www.ti.com>. Additional support documents are listed in the sections of this guide entitled **Related Documentation from Texas Instruments** and **Additional Documentation**. Throughout this document, the acronym **EVM** and the phrase *evaluation module* are synonymous with the PCM4202EVM. This user's guide includes setup and configuration instructions, information regarding absolute operating conditions for power supplies and input/output connections, an electrical schematic, PCB layout drawings, and a bill of materials (BOM) for the EVM.

Contents

1	Introduction	3
2	Getting Started	7
3	Hardware Description and Configuration	8
4	Schematic, PCB Layout, and Bill of Materials	13

List of Figures

1	PCM4202 Functional Block Diagram	3
2	PCM4202EVM Functional Block Diagram	5
3	DIT (Transmitter) Reset Circuitry	13
4	PCM4202EVM Schematic Diagram	14
5	Top Side Silkscreen	16
6	Bottom Side Silkscreen	17
7	Top Layer (Component Side)	18
8	Ground Plane Layer	19
9	Power Plane Layer	20
10	Bottom Layer (Solder Side)	21

List of Tables

1	Absolute Operating Conditions	8
2	Audio Data Format Selection	9
3	System Clock Source Selection	10
4	Sampling Mode Selection: PCM Slave Mode Audio Formats	11
5	Sampling Mode Selection: PCM Master Mode Audio Formats	11
6	Sampling Mode Selection: DSD Output Mode	11
7	Digital High-Pass Filter Configuration	11

8	Digital Interface Transmitter Configuration	12
9	Transmitter Master Clock Configuration.....	12
10	Transmitter Output Mode Configuration.....	12
11	PCM4202EVM Bill of Materials	22

1 Introduction

The PCM4202 is a high-performance, two-channel stereo audio analog-to-digital (A/D) converter designed for use in professional and broadcast audio applications. The PCM4202 features simultaneous 24-bit linear PCM or 1-bit Direct Stream Digital (DSD) data output for both channels. Sampling rates up to 216kHz are supported for PCM output formats, while 64x or 128x oversampled 1-bit data is supported for the DSD output mode. Native support for both PCM and DSD data formats makes the PCM4202 ideal for use in a variety of audio recording and processing applications.

The PCM4202 features 1-bit delta-sigma ($\Delta\Sigma$) modulators employing a novel density modulated dithering scheme, yielding improved dynamic performance. Differential voltage inputs are utilized for the modulators, providing excellent common-mode rejection. On-chip voltage references are provided for the modulators, in addition to generating DC common-mode bias voltage outputs for use with external input circuitry. Linear phase digital decimation filtering is provided for the 24-bit PCM output, with a minimum stop band attenuation of -100dB for all sampling modes.

The PCM output mode features clipping flag outputs for each channel, as well as a digital high-pass filter for DC removal. The PCM4202 is configured using dedicated input pins for sampling mode and audio data format selection, high-pass filter enable/disable, and reset/power-down operation.

A +5V power supply is required for the analog section of the device, while a +3.3V power supply is required for the digital circuitry. Figure 1 shows the functional block diagram of the PCM4202.

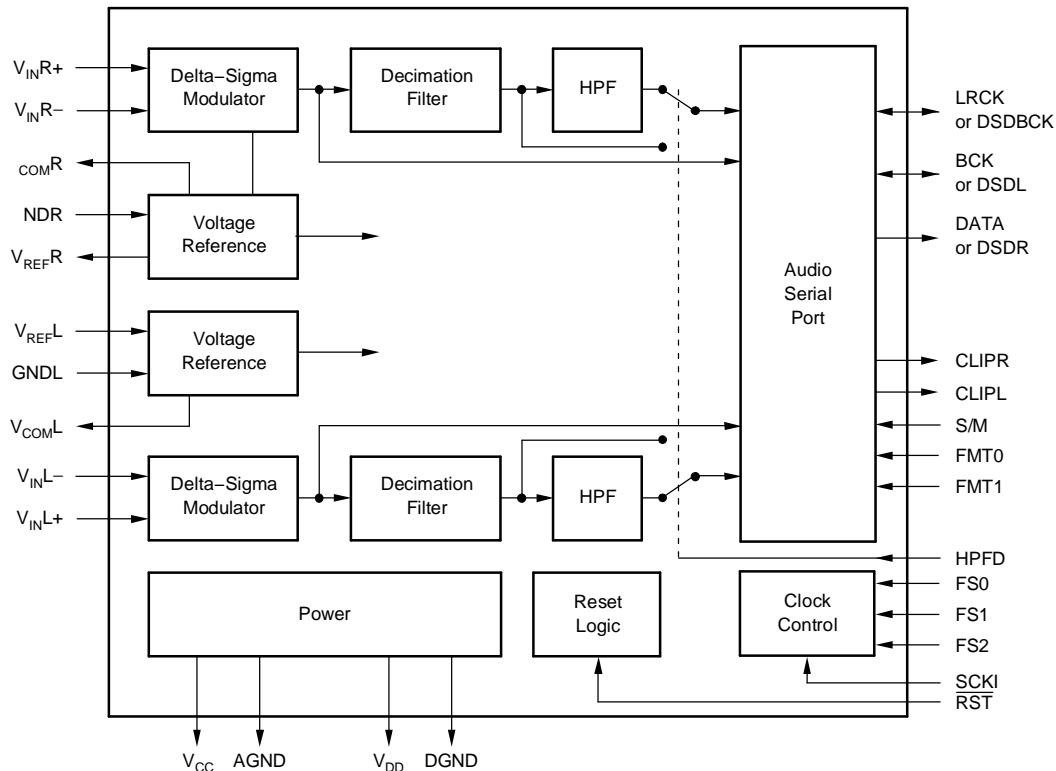

Figure 1. PCM4202 Functional Block Diagram

1.1 **PCM4204EVM Features**

The PCM4202EVM provides a convenient platform for evaluating the performance and functionality of the PCM4202 product. The primary EVM features include:

- Simple configuration using onboard DIP switches
- Two differential voltage inputs supporting either 3-pin XLR or Balanced TRS connections
- Low-noise input buffer circuits utilizing the OPA1632 fully differential audio amplifier
- Two 75 Ω AES3-encoded outputs, supporting operation up to 216kHz sampling rates
- Buffered Audio Serial Port supports a two-channel, 24-bit linear PCM data interface for external hardware and signal processors. Sampling rates up to 216kHz are supported.
- Two onboard system clock oscillators, operating at 22.5792MHz and 24.576MHz respectively, supporting standard PCM sampling rates, including 44.1kHz, 48kHz, 88.2kHz, 96kHz, 176.4kHz, and 192kHz.
- External system clock inputs supporting alternative sampling rates up to 216kHz.

The PCM4202EVM requires +15V, -15V, and +5V analog power supplies. Additionally, a +5V digital power supply is required, with a +3.3V digital supply being derived onboard using a linear voltage regulator IC.

1.2 **PCM4202EVM General Description and Functional Block Diagram**

The PCM4202EVM provides a complete platform for evaluating the performance and features of the PCM4202 stereo audio A/D converter. [Figure 2](#) illustrates the functional block diagram for the evaluation module.

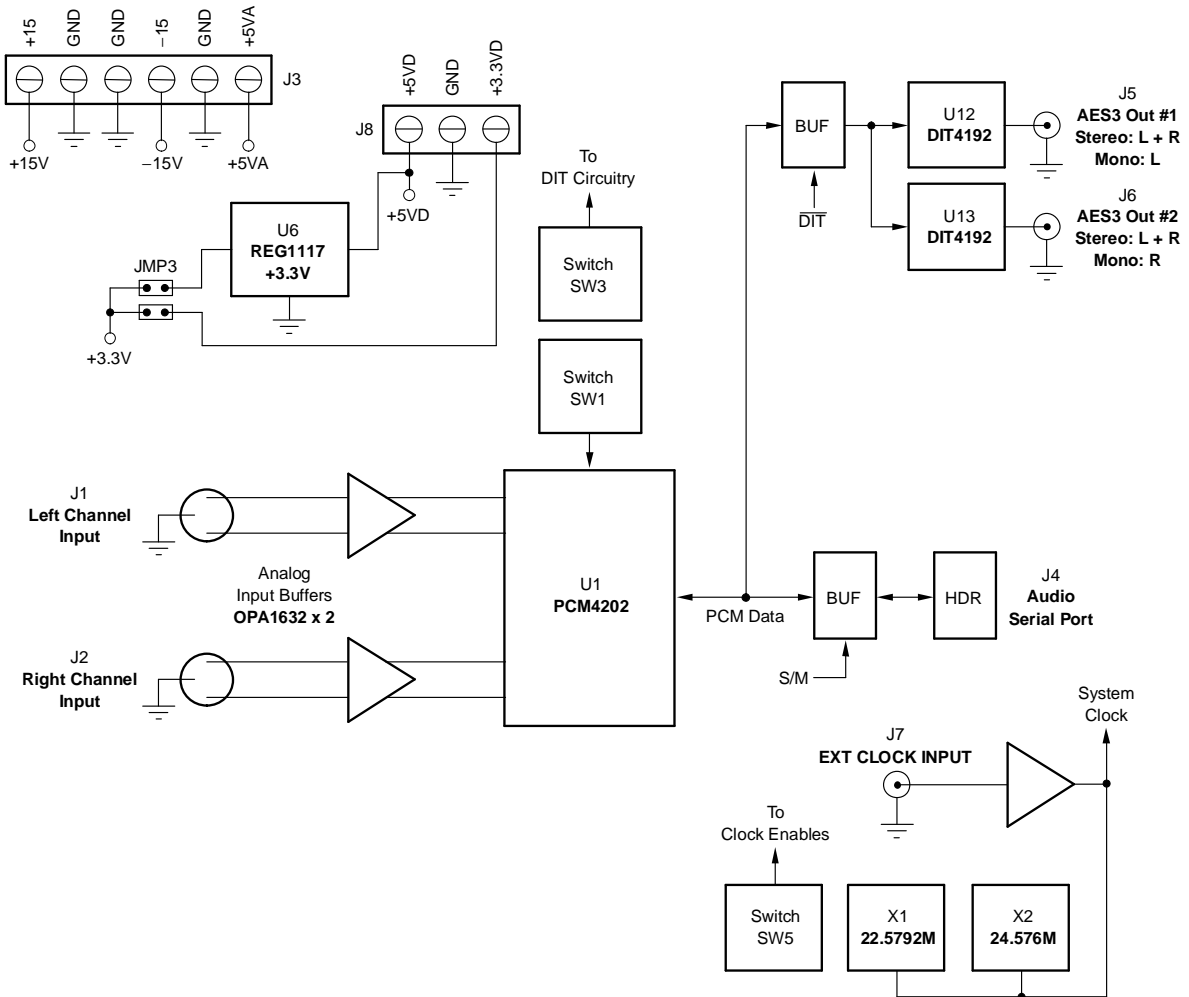

Figure 2. PCM4202EVM Functional Block Diagram

Two differential analog inputs are supported at connectors J1 and J2, corresponding to Left and Right analog input channels, respectively. These connectors support either 3-pin male XLR or balanced TRS input plugs. Each of the analog inputs is buffered and filtered using a low noise input circuit, utilizing a Texas Instruments OPA1632 fully differential amplifier. The output of each buffer circuit is connected to a corresponding differential input of the PCM4202. The PCM4202 is then used to convert the analog signal to either a 24-bit linear PCM or 1-bit DSD representation in the digital domain.

The 24-bit PCM or 1-bit DSD data output is made available at header J4. The 24-bit PCM audio data is also made available at the AES3 encoded data outputs provided at RCA jacks J5 and J6. The buffered header is convenient for interfacing to external development hardware or digital signal processors, while the AES3 encoded outputs may be connected to audio test systems or commercial audio equipment.

Power is connected to the board at either terminal block J3 for the analog supplies, or at terminal block J8 for the digital supplies.

Manual reset circuits are provided for both the PCM4202 (U1) and the AES3 transmitters (U12 and U13). The ADC RESET switch (SW2) is utilized for resetting the A/D converter, while the DIT RESET switch (SW4) is utilized for resetting the AES3 transmitters.

The system or master clock for the evaluation module may be generated onboard or by an external clock source. Oscillators X1 and X2 operate at fixed clock frequencies of 22.5792MHz and 24.576MHz, respectively. The oscillators provide low jitter clock sources for measuring the performance of the PCM4202 in Master mode operation. Alternatively, an external clock source may be connected at J7 for Master mode operation, supporting alternate system clock and sampling frequencies. For Slave mode operation, the system clock is provided from an external source through header J4 and buffer U9. Switch SW5 provides clock configuration control for the oscillators and the external clock input at connector J7.

1.3 **Related Documentation from Texas Instruments**

The following documents provide information regarding Texas Instrument integrated circuits used in the assembly of the PCM4202EVM. The latest revisions of these documents are available from the TI web site at <http://www.ti.com>.

Data Sheet	Literature Number
PCM4202 Datasheet	SBAS290
DIT4192 Datasheet	SBOS229
OPA227 Datasheet	SBOS110
OPA1632 Datasheet	SBOS286
REG1117 Datasheet	SBVS001
SN74AHC08 Datasheet	SCLS236
SN74AHC14 Datasheet	SCLS238
SN74ALVC245 Datasheet	SCES271
SN74LVC1G125 Datasheet	SCES223

1.4 **Additional Documentation**

The following documents or references provide information regarding selected non-TI components used in the assembly of the PCM4202EVM. These documents are available from the corresponding manufacturer.

Document/Reference	Manufacturer
SM7745H Series CMOS Oscillators	Pletronics (http://www.pletronics.com)

2 Getting Started

This section provides information regarding handling and unpacking the PCM4202EVM, as well as absolute operating conditions for the unit.

2.1 Electrostatic Discharge Warning

CAUTION
Failure to observe proper ESD handling precautions may result in damage to EVM components.

Many of the components on the PCM4202EVM are susceptible to damage by electrostatic discharge (ESD). Customers are advised to observe proper ESD handling procedure when unpacking and handling the EVM, including the use of a grounded wrist strap at an approved ESD workstation. Failure to observe ESD handling procedures may result in damage to EVM components.

2.2 EVM Package Contents

Upon opening the PCM4202EVM package, please check to make sure that the following items are included:

- One PCM4202EVM
- One printed copy of the PCM4202 product datasheet
- One printed copy of this PCM4202EVM User's Guide

If any of these items are missing, please contact the Texas Instruments Product Information Center nearest you to inquire about replacements.

2.3 Absolute Operating Conditions

CAUTION
Exceeding the absolute operating conditions may result in damage to the evaluation module and/or the equipment connected to it.

The user should be aware of the absolute operating conditions for the PCM4202EVM. [Table 1](#) summarizes the critical data points.

Table 1. Absolute Operating Conditions

	Min	Max	Units
Power Supplies			
+15V	+5.0	+16.0	V
-15V	-5.0	-16.0	V
+5VA	+4.5	+5.5	V
+5VD	+4.5	+5.5	V
EXT +3.3V	+3.0	+3.6	V
Audio Serial Port (J4)			
V _{IH} , Input High Voltage (V _{DD} = +3.0V to +3.6V)	0.7 × V _{DD}	V _{DD} + 0.3	V
V _{IL} , Input Low Voltage (V _{DD} = +3.0V to +3.6V)	-0.3	0.3 × V _{DD}	V
Analog Inputs (connectors J1 and J2)			
Differential Input Voltage, RMS		7.9	V _{RMS}
Differential Input Voltage, Peak-to-Peak		22.3	V _{PP}

3 Hardware Description and Configuration

This section provides hardware description and configuration information for the PCM4202EVM.

3.1 Power Supply Configuration

The PCM4202EVM requires three analog power supplies and one digital power supply for operation. The analog supplies are connected at terminal block J3, while the digital supply is connected at terminal block J8.

Analog supplies include +15V and -15V DC for powering the input buffer circuits, as well as +5.0V DC for powering the analog section of the PCM4202. All supplies should be rated for at least 500mA of output current.

The digital supply requires +5.0V DC and should be rated for at least 500mA of output current. The +5.0V supply is regulated to +3.3V DC by an onboard Texas Instruments REG1117 linear voltage regulator (U6), which is used to power the digital section of the PCM4202 and the majority of the support logic circuitry. The core logic and line driver sections of the AES3 transmitters (U12 and U13) utilize the +5.0V digital supply directly.

An optional external +3.3V DC digital power supply is supported at terminal block J8. Jumper JMP3 is utilized to select either the onboard voltage regulator (U6) or an external +3.3V power source. Shorting pins 1 and 2 together using the supplied jumper block selects the onboard +3.3V voltage regulator. Shorting pins 3 and 4 together will select the external +3.3V supply terminal (EXT +3.3VD) on terminal block J14. Only one source may be selected at any time.

3.2 Analog Inputs

The PCM4202EVM includes two Neutrik combo XLR connectors, which accept either 3-pin male XLR or ¼-inch TRS phono plugs. The connectors are numbered J1 and J2, corresponding to the left and right channels, respectively.

The analog inputs can accept up to a $7.9V_{RMS}$ (or $22.3V_{PP}$) differential input signal. This signal is then attenuated by a factor of 3.7 by the input buffer circuit, which corresponds to the $6.0V_{PP}$ full-scale differential input voltage for the PCM4202 analog inputs.

The input buffer circuits are each comprised of a single OPA1632 fully differential audio amplifier and associated passive components. The input buffer provides active attenuation and low pass filtering for the analog input signal. The OPA1632 outputs are DC level-shifted by approximately +2.5V using the amplifiers V_{COMIN} input (pin 2), which are connected to a buffered version of either the PCM4202 V_{COML} (pin 3) or V_{COMR} outputs (pin 26).

3.3 Audio Data Format Selection

Switch SW1 is used to select the audio data format for the PCM4202. [Table 2](#) summarizes the available audio data formats for both Slave and Master mode operation and the corresponding SW1 switch settings.

Table 2. Audio Data Format Selection

FMT1	FMT0	Audio Data Format (Slave or Master Mode)
LO	LO	24-Bit Left Justified PCM Data
LO	HI	24-Bit I ² S PCM Data
HI	LO	24-Bit Right Justified PCM Data
HI	HI	DSD Output Mode (Master Mode only)

For Slave mode operation, the Audio Serial Port header (connector J4) is utilized to interface to a Master device, such as a digital signal processor, FPGA, or an audio test system with a synchronous serial port interface. The system clock (SCKI), bit clock (BCK), and left/right word clock (LRCK) are generated by the Master device and are used to drive the SCKI (pin 18), BCK (pin 16), and LRCK (pin 17) inputs of the PCM4202. Serial audio data is output at DATA (pin 15). Slave mode supports PCM-formatted output data only. DSD output data is available only in Master mode.

For Master mode, the system clock is provided by one of the sources described in Section 3.4 of this document. The PCM4202 internally generates the BCK and LRCK clocks, which are then output to the Audio Serial Port header (connector J4) and the AES3 digital interface transmitters, which then drive output connectors J5 and J6.

Master mode may also be configured to support 1-bit DSD-formatted audio output data, as shown in [Table 2](#). For the DSD mode formats, header J4 provides the output interface. The DATA output functions as the Right channel DSD output (DSDR), the BCK output servers as the left channel DSD output (DSDL), and the LRCK output becomes the DSD bit clock (DSDBCK).

3.4 System Clock Configuration

Switch SW5 is used to select the system clock source for the PCM4202EVM. [Table 3](#) summarizes the available clock source options. The onboard oscillators support standard PCM sampling rates in Master mode, including 44.1kHz, 48kHz, 88.2kHz, 96kHz, 176.4kHz, and 192kHz. The external clock input (connector J7) may be used to supply alternate system clock frequencies that support alternative sample rates.

Table 3. System Clock Source Selection

Switch SW5			System Clock Source	Used for Master or Slave Mode Operation?
EXT	OSC1	OSC0		
LO	LO	LO	External clock input at J7	Master
HI	LO	LO	External clock input at the SCKI pin of header J4	Slave
HI	LO	HI	Oscillator X1, 22.5792MHz	Master
HI	HI	LO	Oscillator X2, 22.576MHz	Master

3.5 Sampling Mode Selection

The sampling mode of the PCM4202 is selected using switch SW1. [Table 4](#) through [Table 6](#) summarize the available sampling modes for both PCM and DSD output modes.

Single Rate sampling mode is designed for output sampling rates up to 54kHz. The modulator oversampling rate is set to 128x.

Dual Rate sampling mode is designed for output sampling rates greater than 54kHz and up to 108kHz. The modulator oversampling rate is set to 64x.

Quad Rate sampling mode is designed for output sampling rates greater than 108kHz and up to 216kHz. The modulator oversampling rate is set to 32x.

Table 4. Sampling Mode Selection: PCM Slave Mode Audio Formats

FS2	FS1	FS0	Sampling Mode
LO	LO	LO	Single Rate with Clock Auto-Detection
LO	LO	HI	Dual Rate with Clock Auto-Detection
LO	HI	LO	Quad Rate with Clock Auto-Detection
LO	HI	HI	Reserved
HI	LO	LO	Reserved
HI	LO	HI	Reserved
HI	HI	LO	Reserved
HI	HI	HI	Reserved

Table 5. Sampling Mode Selection: PCM Master Mode Audio Formats

FS2	FS1	FS0	Sampling Mode
LO	LO	LO	Single Rate with $f_{SCKI} = 768f_S$
LO	LO	HI	Single Rate with $f_{SCKI} = 512f_S$
LO	HI	LO	Single Rate with $f_{SCKI} = 384f_S$
LO	HI	HI	Single Rate with $f_{SCKI} = 256f_S$
HI	LO	LO	Dual Rate with $f_{SCKI} = 384f_S$
HI	LO	HI	Dual Rate with $f_{SCKI} = 256f_S$
HI	HI	LO	Quad Rate with $f_{SCKI} = 192f_S$
HI	HI	HI	Quad Rate with $f_{SCKI} = 128f_S$

Table 6. Sampling Mode Selection: DSD Output Mode

FS2	FS1	FS0	Sampling Mode
LO	LO	LO	128 f_S DSD Output Rate with $f_{SCKI} = 768f_S$
LO	LO	HI	128 f_S DSD Output Rate with $f_{SCKI} = 512f_S$
LO	HI	LO	128 f_S DSD Output Rate with $f_{SCKI} = 384f_S$
LO	HI	HI	128 f_S DSD Output Rate with $f_{SCKI} = 256f_S$
HI	LO	LO	64 f_S DSD Output Rate with $f_{SCKI} = 384f_S$
HI	LO	HI	64 f_S DSD Output Rate with $f_{SCKI} = 256f_S$
HI	HI	LO	Reserved
HI	HI	HI	Reserved

3.6 Digital High-Pass Filter

The PCM4202 includes a digital high-pass filter function for both channels, designed for removing the DC component from the digitized signal. The high-pass filter is not available when using the DSD output mode. The high-pass filter function may be enabled or disabled using the HPFD switch on SW1. [Table 7](#) summarizes the operation of the HPFD switch.

Table 7. Digital High-Pass Filter Configuration

HPFD	Digital High-Pass Filter Function
LO	Enabled
HI	Disabled

3.7 Digital Interface Transmitter Configuration

Two Texas Instruments DIT4192 digital interface transmitters provide AES3-encoded outputs for the PCM4202EVM. Switch SW3 is utilized to configure the transmitters. The outputs of the transmitters are available at connectors J5 and J6, which are RCA phono jacks. These outputs are designed for use with 75Ω coaxial cable connections.

The transmitters are enabled using the $\overline{\text{DIT}}$ switch of SW3. The $\overline{\text{DIT}}$ switch operation is summarized in [Table 8](#).

Table 8. Digital Interface Transmitter Configuration

DIT	Digital Interface Filter Function
LO	Enabled
HI	Disabled

The audio data format for the transmitters is hardwired for 24-bit I²S data format. When using the transmitters, the PCM4202 audio data format must be set to 24-bit I²S, as shown in [Table 2](#).

Like the PCM4202, the DIT4192 transmitters must be configured for the proper master (or system) clock frequency. The transmitter master clock is driven by the same source as the PCM4202 system clock, as described in Section 3.4 of this document. [Table 9](#) summarizes the master clock options for the DIT4192 transmitters using switch SW3.

Table 9. Transmitter Master Clock Configuration

CLK1	CLK0	Transmitter MCLK Frequency
LO	LO	128f _S
LO	HI	256f _S
HI	LO	384f _S
HI	HI	512f _S

The DIT4192 transmitters may be operated in either Stereo or Mono mode. In Stereo mode, two channels of audio data are transmitted at the input sampling frequency. In Mono mode, two consecutive samples of only one channel are transmitted at one-half the input sampling rate. The Mono mode is useful for performance testing with f_S = 176.4kHz or f_S = 192kHz with a system that can only accept only half these rates. This is the case with the Audio Precision System Two Cascade or Cascade Plus test system, which was used for factory performance testing of the PCM4202. Mono mode can be used in conjunction with the Audio Precision Dual BNC digital input mode to test at sampling rates up to 216kHz.

The MONO switch on SW3 is used to enable or disable Mono mode operation. [Table 10](#) summarizes the operation of the MONO switch.

Table 10. Transmitter Output Mode Configuration

MONO	Transmitter Output Mode
LO	Stereo Mode Left and Right channel data are output on both J5 and J6
HI	Mono Mode Left channel data is output on J5 Right channel data is output on J6

3.8 Reset Operations

The PCM4202EVM includes two reset switches, SW2 and SW4. Both are momentary contact pushbutton switches that are normally open. SW2 provides the manual reset for the PCM4202 (U1), while switch SW4 provides the manual reset for the two DIT4192 transmitters (U12 and U13).

The PCM4202 may be reset at any time by momentarily pressing and then releasing switch SW2. This generates a reset pulse and initiates a reset sequence for the device.

For the DIT reset function, the output of the reset circuit is connected to the \overline{RST} pins of DIT4192 transmitters (U12 and U13). The transmitters may be reset only when the \overline{DIT} switch of SW3 is set LO by momentarily pressing and then releasing switch SW4. If the \overline{DIT} switch is set HI, the output of the AND gate in the reset circuit is forced low, which will force both transmitters into power-down mode. The transmitter reset circuit is shown in [Figure 3](#).

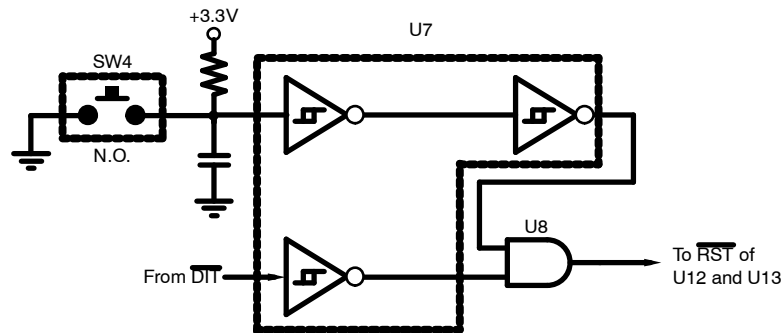

Figure 3. DIT (Transmitter) Reset Circuitry

4 Schematic, PCB Layout, and Bill of Materials

This section provides the electrical schematic and physical layout information for the PCM4202EVM. The bill of materials is included as a component reference.

NOTE

Board layouts are not to scale. These figures are intended to show how the board is laid out; they are not intended to be used for manufacturing PCM4202EVM PCBs.

4.1 Schematic

The electrical schematic for the PCM4202EVM is shown in [Figure 4](#). The components shown in the schematic are listed in [Table 11](#) for reference.

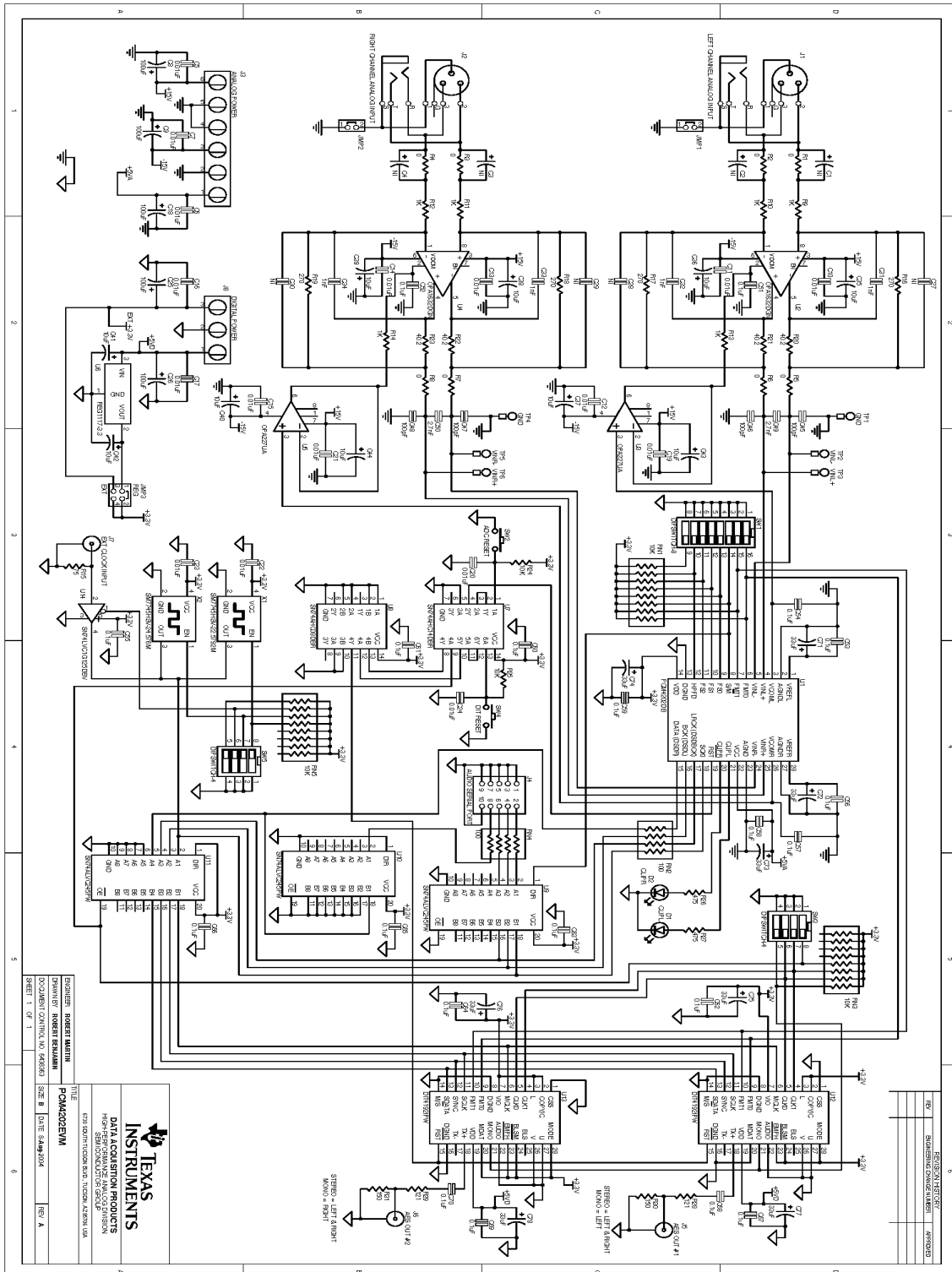

Figure 4. PCM4202EVM Schematic Diagram

4.2 PCB Layout

The PCM4202EVM is a 4-layer printed circuit board with the following layer structure:

- Layer 1: Top (Component Side)
- Layer 2: Ground Plane
- Layer 3: Power
- Layer 4: Bottom (Solder Side)

The ground plane doubles as a heat sink for the PCM4202 PowerPAD package. Refer to the product datasheet for more information on the purpose and application of the PowerPAD connection.

[Figure 5](#) through [Figure 10](#) show the top side silk screen, along with the top, ground plane, power, and bottom layers of the printed circuit board.

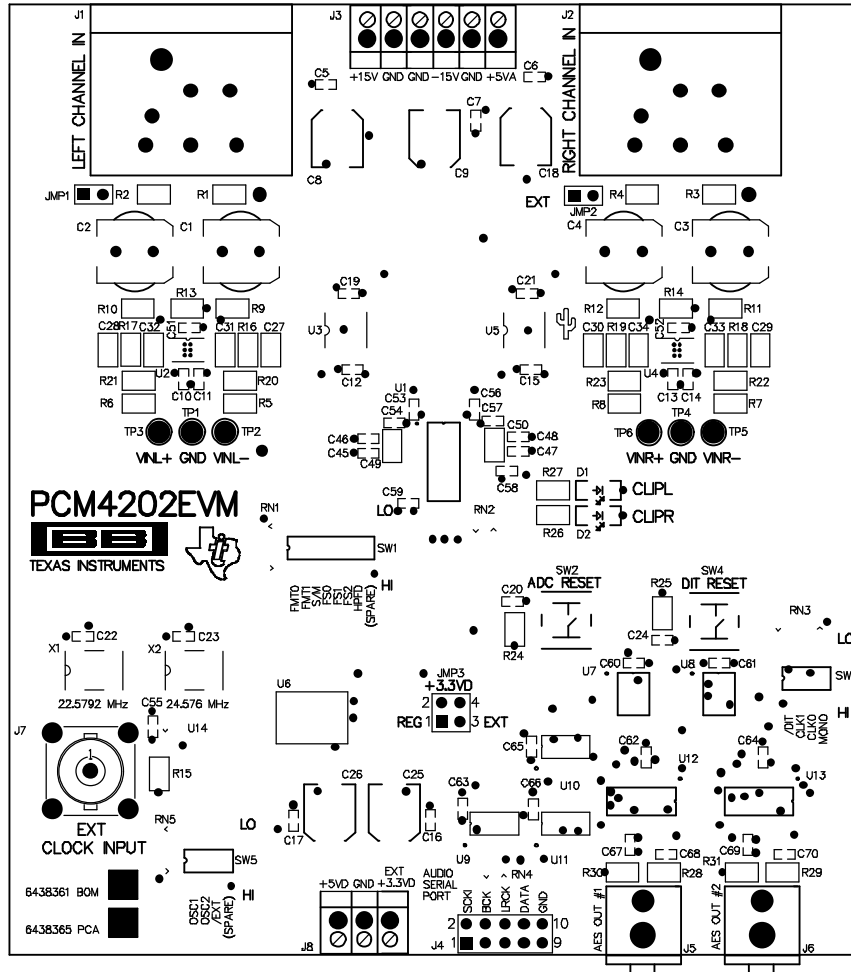

Figure 5. Top Side Silkscreen

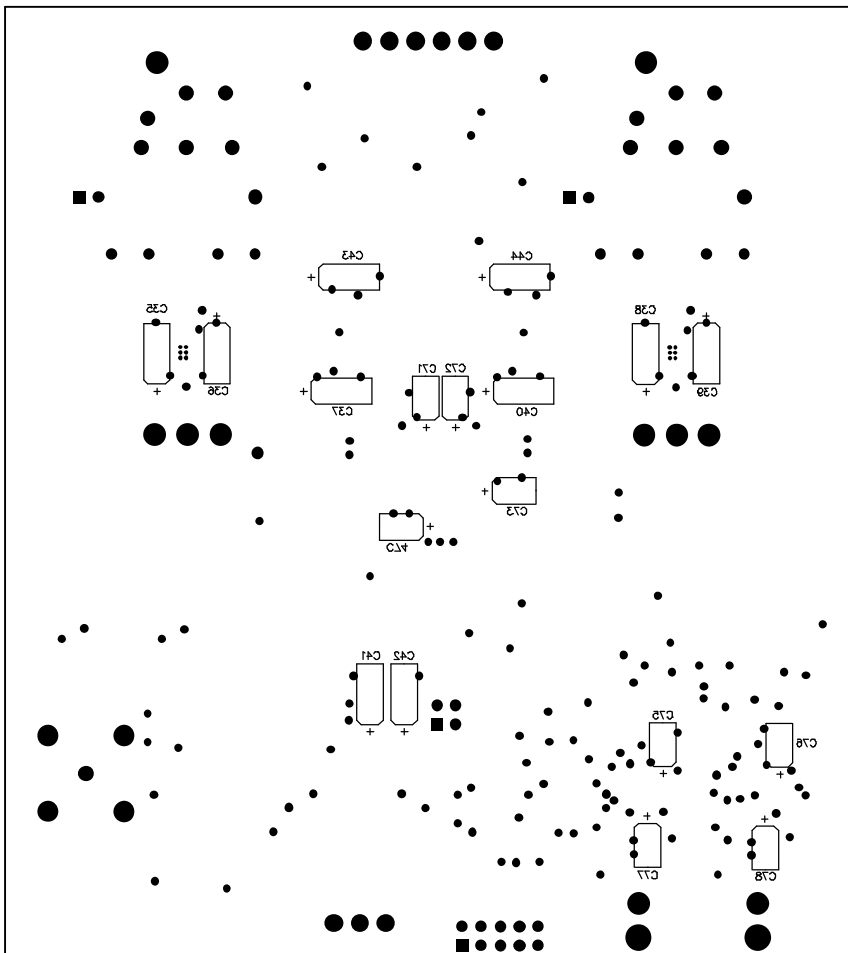

Figure 6. Bottom Side Silkscreen

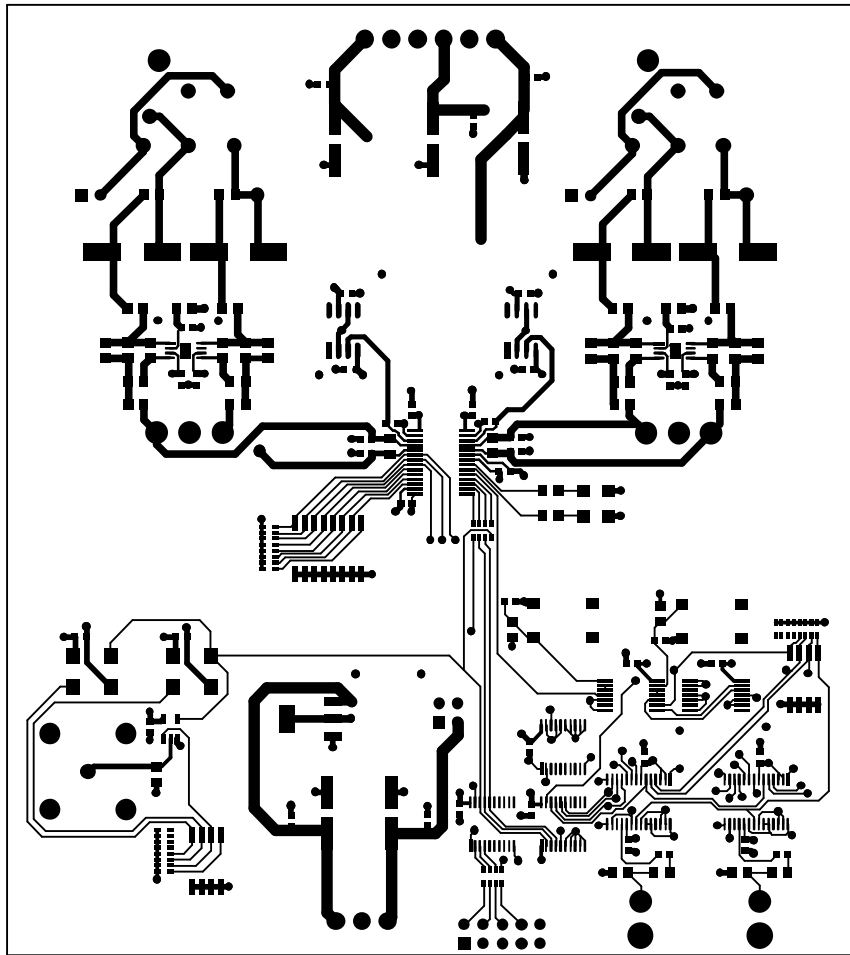

Figure 7. Top Layer (Component Side)

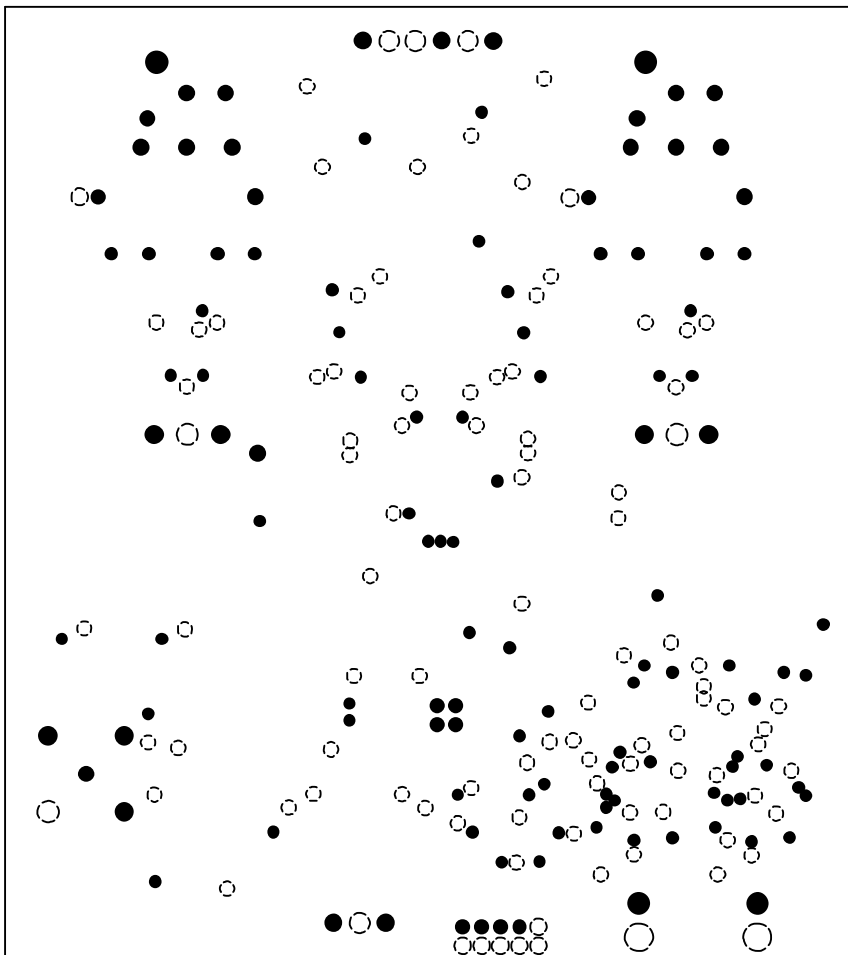

Figure 8. Ground Plane Layer

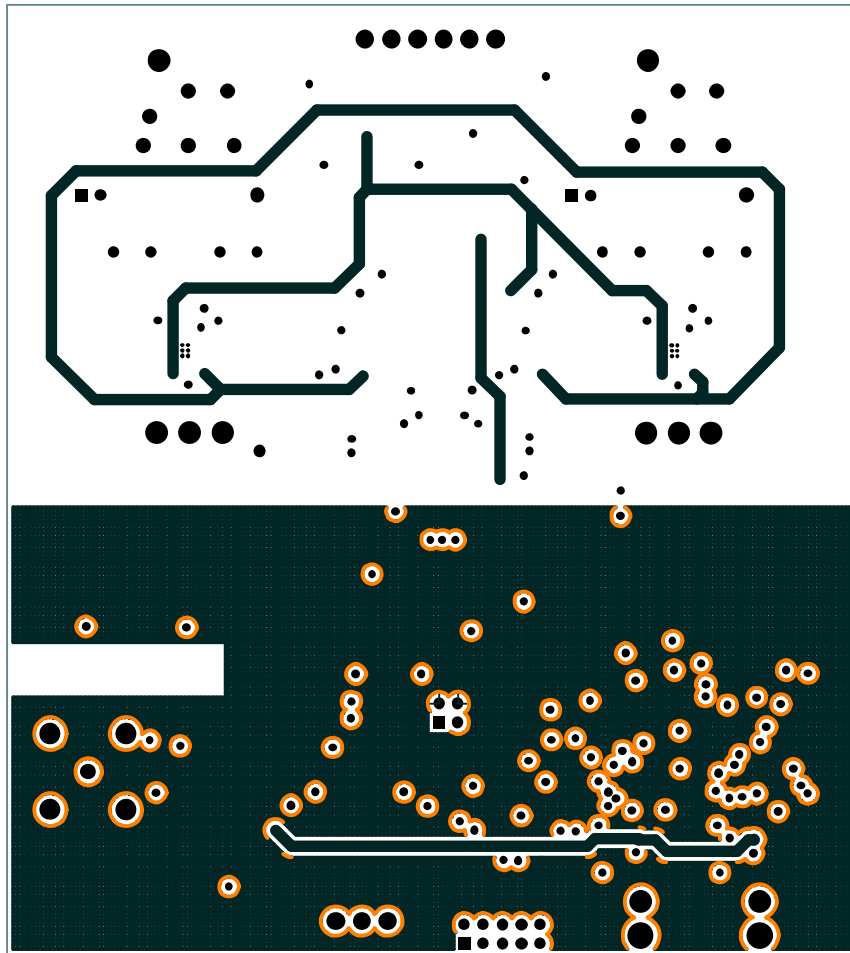

Figure 9. Power Plane Layer

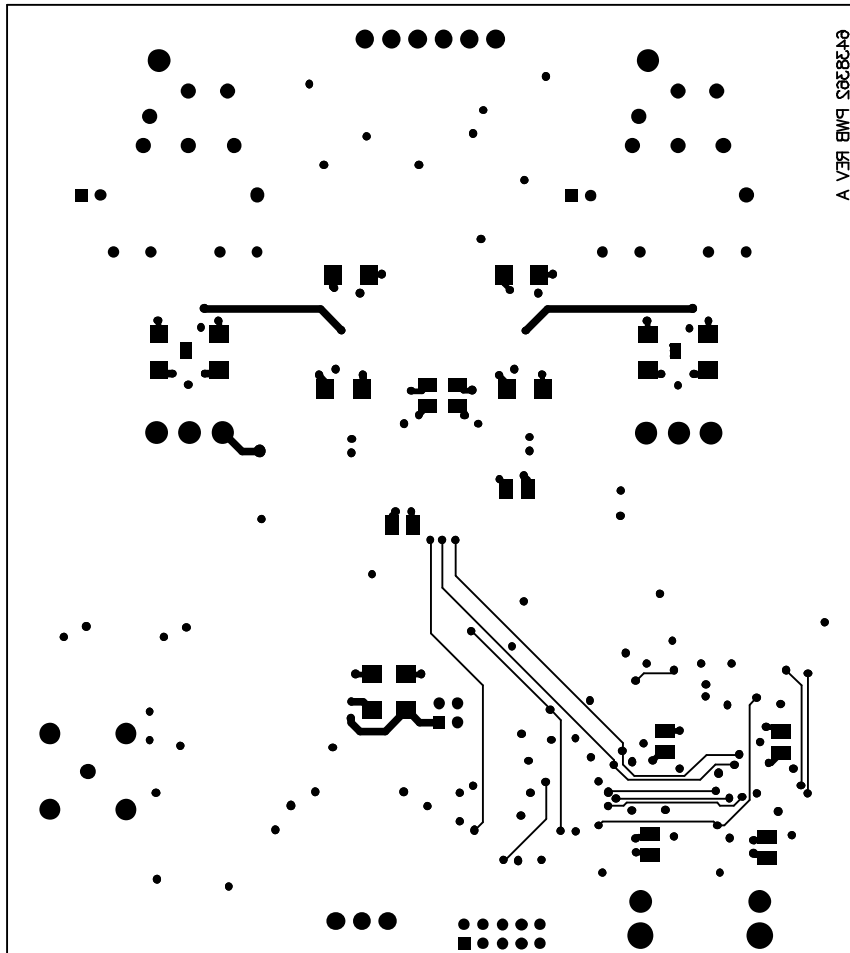

Figure 10. Bottom Layer (Solder Side)

4.3 Bill of Materials

The Bill of Materials, listing the components used in the assembly of the PCM4202EVM, is shown in [Table 11](#).

Table 11. PCM4202EVM Bill of Materials

ITEM	VALUE	Ref Des	QTY PER BOARD	MFR	MFR PART NUMBER	DESCRIPTION
1	100pF	C45-C48	4	Kemet	C0603C101J5GACTU	Chip Capacitor, C0G Ceramic, 100pF ±5%, 50WV, Size = 0603
2	1nF	C31-C34	4	Kemet	C0805C102J3GAC	Chip Capacitor, C0G Ceramic, 1nF ±5%, 25WV, Size = 0805
3	2.7nF	C49, C50	2	Kemet	C0805C272J3GAC	Chip Capacitor, C0G Ceramic, 2.7nF ±5%, 25WV, Size = 0805
4	0.01μF	C5-C7, C10-C17, C19-C24	17	Kemet	C0603C103J5RACTU	Chip Capacitor, X7R Ceramic, 0.01μF ±5%, 50WV, Size = 0603
5	0.1μF	C51-C70	20	Kemet	C0603C104J4RACTU	Chip Capacitor, X7R Ceramic, 0.1μF ±5%, 16WV, Size = 0603
6	10μF	C35-C44	10	Kemet	T494C106K025AS	Chip Capacitor, Low ESR Tantalum, 10μF ±10%, 25WV, Size = C
7	33μF	C71-C78	8	Kemet	T494B336K010AS	Chip Capacitor, Low ESR Tantalum, 33μF ±10%, 10WV, Size = B
8	100μF	C8, C9, C18, C25, C26	5	Panasonic	EEV-FK1E101XP	Capacitor, SMT Aluminum Electrolytic, 100μF ±20%, 25WV
9		D1, D2	2	Lumex	SML-LX1206IC-TR	Red LED, Surface Mount, Size = 1206
10		J1, J2	2	Neutrik	NCJ6FI	Combo Connector, Female XLR and TRS, Vertical PC Mount
11		J3	1	Weidmuller	9967720000	3.5mm PCB Terminal Block, 6 poles
12		J4	1	Samtec	TSW-105-07-G-D	Terminal Strip, 10-pin (5x2)
13		J5, J6	2	CUI Stack	RJC-041	RCA Phono Jack, Black Shell
14		J7	1	Kings Electronics	KC-79-274-M06	BNC Connector, Female, PC Mount
15		J8	1	Weidmuller	169968000	3.5mm PCB Terminal Block, 3 poles
16		JMP1, JMP2	2	Samtec	TSW-102-07-G-S	Terminal Strip, 2-pin (2x1)
17		JMP3	1	Samtec	TSW-102-07-G-D	Terminal Strip, 4-pin (2x2)
18	0	R1-R8	8	Panasonic	ERJ-6EY0R00V	Chip Resistor, 0Ω, Shunt, Size = 0805
19	40.2	R20-R23	4	Panasonic	ERJ-6EN-F40R2V	Chip Resistor, Thick Film, 1% Tolerance, 40.2Ω, 1/10W, Size = 0805
20	75	R15	1	Panasonic	ERJ-6ENF75R0V	Chip Resistor, Thick Film, 1% Tolerance, 75Ω, 1/10W, Size = 0805
21	121	R28, R29	2	Panasonic	ERJ-6ENF1210V	Chip Resistor, Thick Film, 1% Tolerance, 121Ω, 1/10W, Size = 0805
22	150	R30, R31	2	Panasonic	ERJ-6ENF1500V	Chip Resistor, Thick Film, 1% Tolerance, 150Ω, 1/10W, Size = 0805
23	270	R16-R19	4	Panasonic	ERA-6YEB271V	Chip Resistor, Metal Film, 0.1% Tolerance, 270Ω, 1/10W, Size = 0805
24	475	R26, R27	2	Panasonic	ERJ-6ENF4750V	Chip Resistor, Thick Film, 1% Tolerance, 475Ω, 1/10W, Size = 0805
25	1K	R9-R14	6	Panasonic	ERA-6YEB102V	Chip Resistor, Metal Film, 0.1% Tolerance, 1kΩ, 1/10W, Size = 0805
26	10K	R24, R25	2	Panasonic	ERJ-6ENF1002V	Chip Resistor, Thick Film, 1% Tolerance, 10kΩ, 1/10W, Size = 0805
27	100	RN2, RN4	2	CTS	742C083101J	Thick Film Chip Resistor Array, 100Ω, 8-Terminal, 4 Resistors, Isolated

Table 11. PCM4202EVM Bill of Materials (continued)

ITEM	VALUE	Ref Des	QTY PER BOARD	MFR	MFR PART NUMBER	DESCRIPTION
28	10K	RN1, RN3, RN5	3	CTS	742C163103J	Thick Film Chip Resistor Array, 10k Ω , 16-Terminal, 8 Resistors, Isolated
29		SW1	1	ITT Industries/ C&K	TDA08H0SK1	DIP Switch, 8 Element, Half-Pitch, Surface-Mount, Tape Sealed
30		SW2, SW4	2	Omron	B3S-1000	Momentary Tact Switch, SMT without Ground Terminal
31		SW3, SW5	2	ITT Industries/ C&K	TDA04H0SK1	DIP Switch, 4 Element, Half-Pitch, Surface-Mount, Tape Sealed
32		U1	1	Texas Instruments	PCM4202DB	Stereo Audio A/D Converter
33		U2, U4	2	Texas Instruments	OPA1632DGN	Fully-Differential Audio Amplifier
34		U3, U5	2	Texas Instruments	OPA227UA	Precision Operational Amplifier
35		U7	1	Texas Instruments	SN74AHC14DBR	Hex Schmitt-Trigger Inverters
36		U8	1	Texas Instruments	SN74AHC08DBR	Quad 2-Input Positive AND Gates
37		U9-U11	3	Texas Instruments	SN74ALVC245PW	Octal Bus Transceiver with Tri-State Outputs
38		U12, U13	2	Texas Instruments	DIT4192IPW	192kHz Digital Audio Transmitter
39		U14	1	Texas Instruments	SN74LVC1G125DBV	Single Non-Inverting Buffer with Tri-State Output
40		U6	1	Texas Instruments	REG1117-3.3	Linear Voltage Regulator, +3.3V
41		TP1-TP6	6	Keystone Electronics	5006	PCB Test Point, Compact, Through-hole
42		X1	1	Pletronics	SM7745HSW-22.5792M	+3.3V Surface-Mount Clock Oscillator, CMOS Output with Active High Enable, 22.5792MHz \pm 50ppm
43		X2	1	Pletronics	SM7745HSW-24.576M	+3.3V Surface-Mount Clock Oscillator, CMOS Output with Active High Enable, 24.576MHz \pm 50ppm
44			3	Samtec	SNT-100-BK-G-H	Shorting Blocks
42			4	3M Bumpon	SJ-5003	Self-Adhesive Rubber Feet

FCC Warnings

This equipment is intended for use in a laboratory test environment only. It generates, uses, and can radiate radio frequency energy and has not been tested for compliance with the limits of computing devices pursuant to subpart J of part 15 of FCC rules, which are designed to provide reasonable protection against radio frequency interference. Operation of this equipment in other environments may cause interference with radio communications, in which case the user at his own expense will be required to take whatever measures may be required to correct this interference.

EVM IMPORTANT NOTICE

Texas Instruments (TI) provides the enclosed product(s) under the following conditions:

This evaluation kit being sold by TI is intended for use for **ENGINEERING DEVELOPMENT OR EVALUATION PURPOSES ONLY** and is not considered by TI to be fit for commercial use. As such, the goods being provided may not be complete in terms of required design-, marketing-, and/or manufacturing-related protective considerations, including product safety measures typically found in the end product incorporating the goods. As a prototype, this product does not fall within the scope of the European Union directive on electromagnetic compatibility and therefore may not meet the technical requirements of the directive.

Should this evaluation kit not meet the specifications indicated in the EVM User's Guide, the kit may be returned within 30 days from the date of delivery for a full refund. **THE FOREGOING WARRANTY IS THE EXCLUSIVE WARRANTY MADE BY SELLER TO BUYER AND IS IN LIEU OF ALL OTHER WARRANTIES, EXPRESSED, IMPLIED, OR STATUTORY, INCLUDING ANY WARRANTY OF MERCHANTABILITY OR FITNESS FOR ANY PARTICULAR PURPOSE.**

The user assumes all responsibility and liability for proper and safe handling of the goods. Further, the user indemnifies TI from all claims arising from the handling or use of the goods. Please be aware that the products received may not be regulatory compliant or agency certified (FCC, UL, CE, etc.). Due to the open construction of the product, it is the user's responsibility to take any and all appropriate precautions with regard to electrostatic discharge.

EXCEPT TO THE EXTENT OF THE INDEMNITY SET FORTH ABOVE, NEITHER PARTY SHALL BE Liable to the other FOR ANY INDIRECT, SPECIAL, INCIDENTAL, OR CONSEQUENTIAL DAMAGES.

TI currently deals with a variety of customers for products, and therefore our arrangement with the user **is not exclusive**.

TI assumes **no liability for applications assistance, customer product design, software performance, or infringement of patents or services described herein.**

Please read the EVM User's Guide and, specifically, the EVM Warnings and Restrictions notice in the EVM User's Guide prior to handling the product. This notice contains important safety information about temperatures and voltages. For further safety concerns, please contact the TI application engineer.

Persons handling the product must have electronics training and observe good laboratory practice standards.

No license is granted under any patent right or other intellectual property right of TI covering or relating to any machine, process, or combination in which such TI products or services might be or are used.

EVM WARNINGS AND RESTRICTIONS

It is important to operate this EVM with the operating conditions specified within [Table 1](#) of this document.

Exceeding the specified input range may cause unexpected operation and/or irreversible damage to the EVM. If there are questions concerning the input range, please contact a TI field representative prior to connecting the input power.

Applying loads outside of the specified output range may result in unintended operation and/or possible permanent damage to the EVM. Please consult the EVM User's Guide prior to connecting any load to the EVM output. If there is uncertainty as to the load specification, please contact a TI field representative.

During normal operation, some circuit components may have case temperatures greater than 37°C. The EVM is designed to operate properly with certain components above 60°C as long as the input and output ranges are maintained. These components include but are not limited to linear regulators, switching transistors, pass transistors, and current sense resistors. These types of devices can be identified using the EVM schematic located in the EVM User's Guide. When placing measurement probes near these devices during operation, please be aware that these devices may be very warm to the touch.

Mailing Address: Texas Instruments, Post Office Box 655303, Dallas, Texas 75265
Copyright © 2004, Texas Instruments Incorporated

IMPORTANT NOTICE

Texas Instruments Incorporated and its subsidiaries (TI) reserve the right to make corrections, modifications, enhancements, improvements, and other changes to its products and services at any time and to discontinue any product or service without notice. Customers should obtain the latest relevant information before placing orders and should verify that such information is current and complete. All products are sold subject to TI's terms and conditions of sale supplied at the time of order acknowledgment.

TI warrants performance of its hardware products to the specifications applicable at the time of sale in accordance with TI's standard warranty. Testing and other quality control techniques are used to the extent TI deems necessary to support this warranty. Except where mandated by government requirements, testing of all parameters of each product is not necessarily performed.

TI assumes no liability for applications assistance or customer product design. Customers are responsible for their products and applications using TI components. To minimize the risks associated with customer products and applications, customers should provide adequate design and operating safeguards.

TI does not warrant or represent that any license, either express or implied, is granted under any TI patent right, copyright, mask work right, or other TI intellectual property right relating to any combination, machine, or process in which TI products or services are used. Information published by TI regarding third-party products or services does not constitute a license from TI to use such products or services or a warranty or endorsement thereof. Use of such information may require a license from a third party under the patents or other intellectual property of the third party, or a license from TI under the patents or other intellectual property of TI.

Reproduction of information in TI data books or data sheets is permissible only if reproduction is without alteration and is accompanied by all associated warranties, conditions, limitations, and notices. Reproduction of this information with alteration is an unfair and deceptive business practice. TI is not responsible or liable for such altered documentation.

Resale of TI products or services with statements different from or beyond the parameters stated by TI for that product or service voids all express and any implied warranties for the associated TI product or service and is an unfair and deceptive business practice. TI is not responsible or liable for any such statements.

TI products are not authorized for use in safety-critical applications (such as life support) where a failure of the TI product would reasonably be expected to cause severe personal injury or death, unless officers of the parties have executed an agreement specifically governing such use. Buyers represent that they have all necessary expertise in the safety and regulatory ramifications of their applications, and acknowledge and agree that they are solely responsible for all legal, regulatory and safety-related requirements concerning their products and any use of TI products in such safety-critical applications, notwithstanding any applications-related information or support that may be provided by TI. Further, Buyers must fully indemnify TI and its representatives against any damages arising out of the use of TI products in such safety-critical applications.

TI products are neither designed nor intended for use in military/aerospace applications or environments unless the TI products are specifically designated by TI as military-grade or "enhanced plastic." Only products designated by TI as military-grade meet military specifications. Buyers acknowledge and agree that any such use of TI products which TI has not designated as military-grade is solely at the Buyer's risk, and that they are solely responsible for compliance with all legal and regulatory requirements in connection with such use.

TI products are neither designed nor intended for use in automotive applications or environments unless the specific TI products are designated by TI as compliant with ISO/TS 16949 requirements. Buyers acknowledge and agree that, if they use any non-designated products in automotive applications, TI will not be responsible for any failure to meet such requirements.

Following are URLs where you can obtain information on other Texas Instruments products and application solutions:

Products		Applications	
Amplifiers	amplifier.ti.com	Audio	www.ti.com/audio
Data Converters	dataconverter.ti.com	Automotive	www.ti.com/automotive
DSP	dsp.ti.com	Broadband	www.ti.com/broadband
Interface	interface.ti.com	Digital Control	www.ti.com/digitalcontrol
Logic	logic.ti.com	Military	www.ti.com/military
Power Mgmt	power.ti.com	Optical Networking	www.ti.com/opticalnetwork
Microcontrollers	microcontroller.ti.com	Security	www.ti.com/security
RFID	www.ti-rfid.com	Telephony	www.ti.com/telephony
Low Power Wireless	www.ti.com/lpw	Video & Imaging	www.ti.com/video
		Wireless	www.ti.com/wireless

Mailing Address: Texas Instruments, Post Office Box 655303, Dallas, Texas 75265
Copyright © 2007, Texas Instruments Incorporated