

INA231EVM Evaluation Board and Software Tutorial

This user's guide describes the characteristics, operation, and use of the INA231EVM evaluation board. It discusses how to set up and configure the software and hardware, and reviews various aspects of the program operation. Throughout this document, the terms *evaluation board*, *evaluation module*, and *EVM* are synonymous with the INA231EVM. This user's guide also includes information regarding operating procedures and input/output connections, an electrical schematic, printed circuit board (PCB) layout drawings, and a parts list for the EVM.

Contents

1	Overview	3
2	INA231EVM Hardware Setup	4
3	INA231EVM Hardware	6
4	INA231EVM Software Setup	11
5	INA231EVM Software Overview	13
6	INA231EVM Documentation	21

List of Figures

1	Hardware Included with INA231EVM Kit.....	3
2	INA231EVM Hardware Setup	4
3	INA231EVM Test Board Block Diagram	4
4	SM-USB-DIG Platform Block Diagram	5
5	Typical Hardware Test Connections for the INA231EVM	6
6	Connecting the USB Cable to the SM-USB-DIG Platform.....	7
7	Confirmation of SM-USB-DIG Platform Driver Installation.....	7
8	INA231EVM Default Jumper Settings	8
9	Typical Filter Setup.....	10
10	INA231 Shunt Configurations	10
11	INA231EVM Software Installation	11
12	INA231EVM License Agreements.....	12
13	INA231EVM Software Installation Progress	12
14	INA231EVM Software Interface	13
15	INA231EVM Software: Communication Error with the SM-USB-DIG Platform.....	14
16	Setting the A1 Address	15
17	Configuring Operating Mode	16
18	Configuring Conversion Times.....	16
19	Setting the Configuration Register (Calibration Register)	17
20	Setting the Configuration Register (Current LSB)	17
21	Configuring the Alert Pin.....	17
22	INA231 Results Bar	18
23	Theory of Operation Flowchart on the Calculation Tab	18
24	Registers Tab	19

Microsoft, Windows are registered trademarks of Microsoft Corporation.
 I²C is a trademark of NXP Semiconductors.
 WinZIP is a registered trademark of WinZip International LLC.
 All other trademarks are the property of their respective owners.

25	Graphing the INA231 Data	20
26	Auto-Write, Power Button, and Voltage Control	20
27	INA231EVM Schematic.....	21
28	INA231EVM PCB Top Layer (Component Side)	22

List of Tables

1	INA231EVM Kit Contents	3
2	Related Documentation	4
3	Signal Definition of J1 on INA231EVM Board.....	5
4	INA231EVM Test Board Jumper Functions	8
5	INA231 I ² C Address Configuration	14
6	Bill of Materials: INA231EVM	23

1 Overview

The [INA231](#) is a high-side current sensor and power monitor with an I²C™ interface. The INA231 monitors both current and supply voltage, with programmable conversion times and averaging modes. The INA231EVM is a platform for evaluating the performance of the INA231 under various signal, shunt, and supply conditions.

This document gives a general overview of the INA231EVM, and provides a general description of the features and functions to be considered while using this evaluation module.

1.1 INA231EVM Kit Contents

[Table 1](#) summarizes the contents of the INA231EVM kit. [Figure 1](#) shows all of the included hardware. Contact the [Texas Instruments Product Information Center](#) nearest you if any component is missing. It is highly recommended that you also check the [INA231 product folder](#) on the TI web site at www.ti.com to verify that you have the latest versions of the related software.

Table 1. INA231EVM Kit Contents

Item	Quantity
INA231EVM PCB Test Board	1
SM-USB-DIG Platform PCB	1
USB Extender Cable	1
SM-USB-DIG Connector Ribbon Cable	1
User's Guide CD-ROM	1

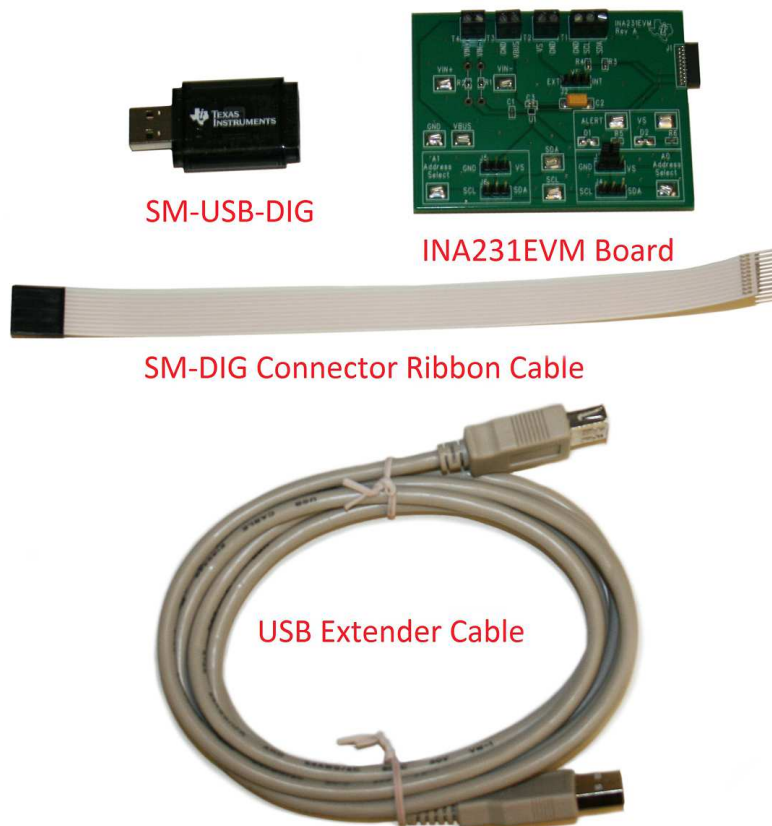

Figure 1. Hardware Included with INA231EVM Kit

1.2 Related Documentation from Texas Instruments

The following documents provide information regarding Texas Instruments' integrated circuits used in the assembly of the INA231EVM. This user's guide is available from the TI web site under literature number **SBOU128**. Any letter appended to the literature number corresponds to the document revision that is current at the time of the writing of this document. Newer revisions may be available from www.ti.com, or call the Texas Instruments' Literature Response Center at (800) 477-8924 or the Product Information Center at (972) 644-5580. When ordering, identify the document by both title and literature number.

Table 2. Related Documentation

Document	Literature Number
INA231 Product Data Sheet	SBOS644
SM-USB-DIG Platform User Guide	SBOU098

2 INA231EVM Hardware Setup

Figure 2 shows the overall system setup for the INA231EVM. The PC runs software that communicates with the SM-USB-DIG Platform. The SM-USB-DIG Platform generates the analog and digital signals used to communicate with the INA231 test board. Connectors on the INA231EVM test board allow the user to connect to the system under test conditions to monitor the power, current, and voltage.

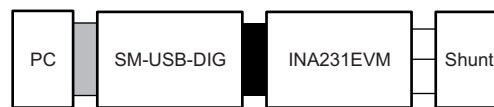

Figure 2. INA231EVM Hardware Setup

2.1 Theory of Operation for INA231 Hardware

A block diagram of the INA231 test board hardware setup is shown in Figure 3. The PCB provides connections to the I²C interface and general-purpose inputs/outputs (GPIOs) on the SM-USB-DIG Platform board. The PCB also provides connection points for external connections of the shunt voltage, bus voltage, and ground.

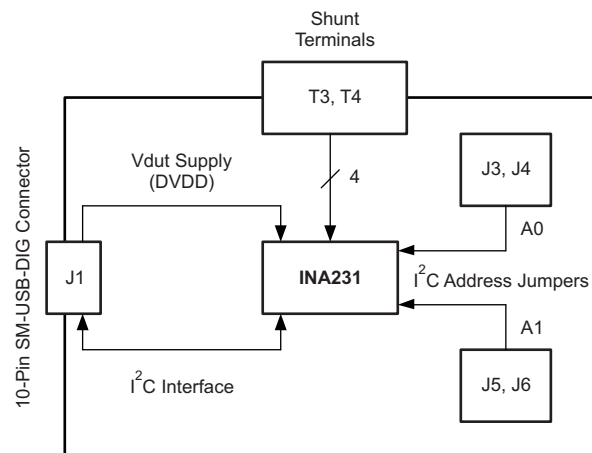

Figure 3. INA231EVM Test Board Block Diagram

2.2 Signal Definitions of H1 (10-Pin Male Connector Socket)

Table 3 lists the pinout for the 10-pin connector socket used to communicate between the INA231EVM and the SM-USB-DIG. It should be noted that the INA231EVM only uses the necessary I²C communication lines (pins 1 and 3) and the V_{DUT} and GND pins (pin 6 and pin 8) to issue commands to the INA231 chip.

Table 3. Signal Definition of J1 on INA231EVM Board

Pin on J1	Signal	Description
1	I2C_SCL	I ² C Clock Signal (SCL)
2	CTRL/MEAS4	GPIO: Control Output or Measure Input
3	I2C_SDA1	I ² C Data Signal (SDA)
4	CTRL/MEAS5	GPIO: Control Output or Measure Input
5	SPI_DOUT1	SPI Data Output (MOSI)
6	V _{DUT}	Switchable DUT Power Supply: +3.3 V, +5 V, Hi-Z (Disconnected) ⁽¹⁾
7	SPI_CLK	SPI Clock Signal (SCLK)
8	GND	Power Return (GND)
9	SPI_CS1	SPI Chip Select Signal (\overline{CS})
10	SPI_DIN1	SPI Data Input (MISO)

⁽¹⁾ When V_{DUT} is Hi-Z, all digital I/O are Hi-Z as well.

2.2.1 Theory of Operation for SM-USB-DIG Platform

Figure 4 shows the block diagram for the SM-USB-DIG Platform. This platform is a general-purpose data acquisition system that is used on several different Texas Instruments evaluation modules. The details of its operation are included in a separate document, [SBOU098](#) (available for download at [www.ti.com](#)). The block diagram shown in Figure 4 gives a brief overview of the platform. The primary control device on the SM-USB-DIG Platform is the [TUSB3210](#). The TUSB3210 is an 8052 microcontroller that has an onboard USB interface. The microcontroller receives information from the host computer that it interprets into power, I²C, SPI, and other digital I/O patterns. During the digital I/O transaction, the microcontroller reads the response of any device connected to the I/O interface. The response from the device is sent back to the PC where it is interpreted by the host computer.

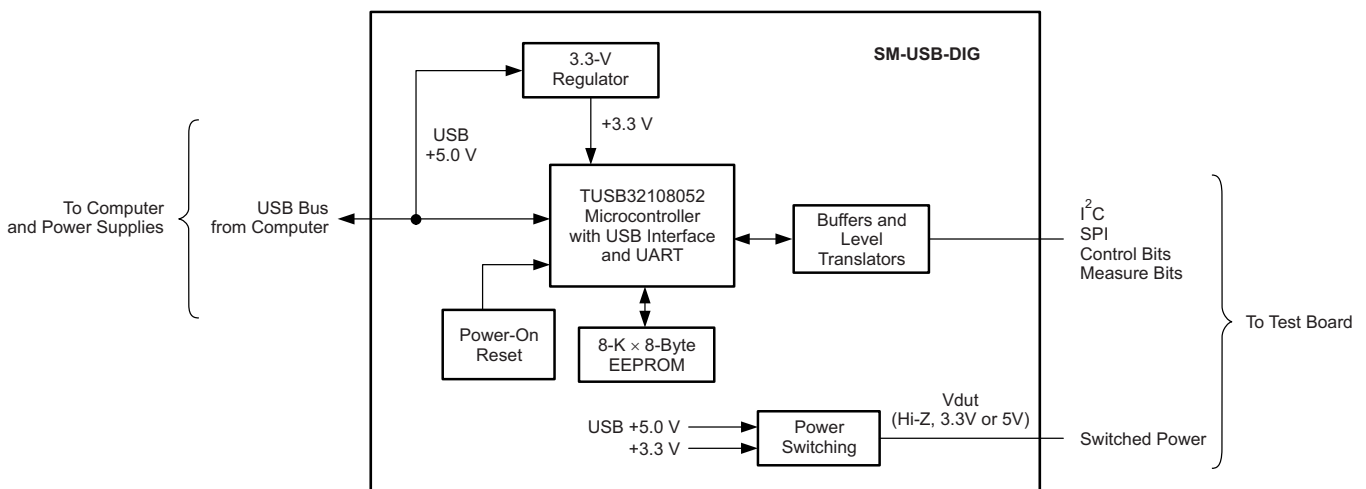

Figure 4. SM-USB-DIG Platform Block Diagram

3 INA231EVM Hardware

Setting up the INA231EVM hardware involves connecting the two PCBs of the EVM together, applying power, connecting the USB cable, and setting the jumpers. This section presents the details of this procedure.

3.1 Electrostatic Discharge Warning

CAUTION

Many of the components on the INA231EVM are susceptible to damage by electrostatic discharge (ESD). Customers are advised to observe proper ESD handling precautions when unpacking and handling the EVM, including the use of a grounded wrist strap at an approved ESD workstation.

3.2 Connecting the Hardware

To set up the INA231EVM and connect the two PCBs of the EVM together (that is, the INA231 Test Board and SM-USB-DIG Platform board), gently slide the male and female ends of the 10-pin connectors together. Make sure that the two connectors are completely pushed together; loose connections may cause intermittent operation.

3.3 Connecting Power

After the EVM and SM-USB-DIG are connected, as [Figure 5](#) illustrates, make the desired V_{BUS} and shunt connections. Typically, setup involves a high- or low-side load and a shunt resistor across V_{IN+} and V_{IN-} . The setup in [Figure 5](#) represents a test scenario with a low-side shunt attached. This source for V_{BUS} is not included with the kit, and its voltage may differ depending on your testing needs. The external power source is connected to the terminal strip T3.

NOTE: It is always necessary to connect the power to the SM-USB-DIG Platform board before connecting the USB cable.

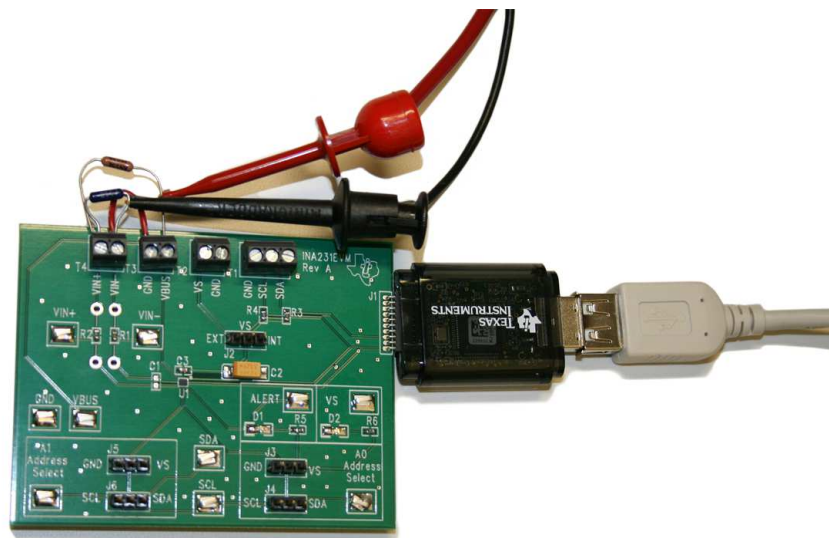

Figure 5. Typical Hardware Test Connections for the INA231EVM

3.4 Connecting the USB Cable to the SM-USB-DIG Platform

Once power is connected, as shown in [Figure 6](#), the computer typically responds with a *Found New Hardware, USB Device* pop-up dialog. The pop-up window typically changes to *Found New Hardware, USB Human Interface Device*. This pop-up indicates that the device is ready to be used. The SM-USB-DIG Platform uses the human interface device drivers that are part of the Microsoft® Windows® operating system.

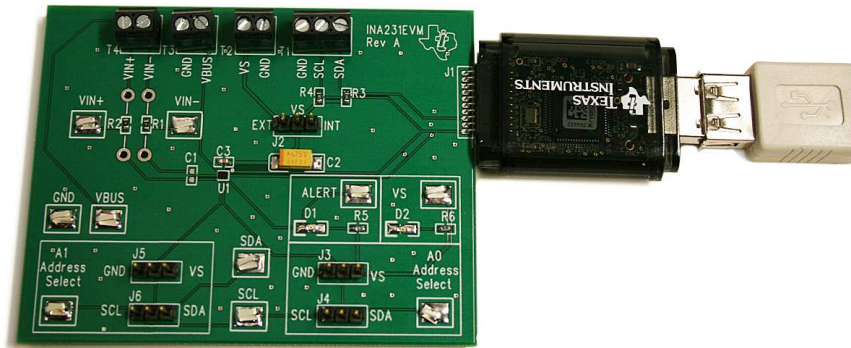

Figure 6. Connecting the USB Cable to the SM-USB-DIG Platform

In some cases, the Windows *Add Hardware Wizard* may pop up. If this prompt appears, allow the system device manager to install the human interface drivers by clicking **Yes** when requested to install drivers. Windows then confirms installation of the drivers with the message shown in [Figure 7](#).



Figure 7. Confirmation of SM-USB-DIG Platform Driver Installation

3.5 INA231EVM Default Jumper Settings

Figure 8 shows the default jumper configuration for the INA231EVM. In general, the jumper settings of the SM-USB-DIG Platform do not need to be changed. You may want to change some of the jumpers on the INA231EVM board to match your specific configuration. For example, you may wish to set a specific I²C address by configuring J3-J6.

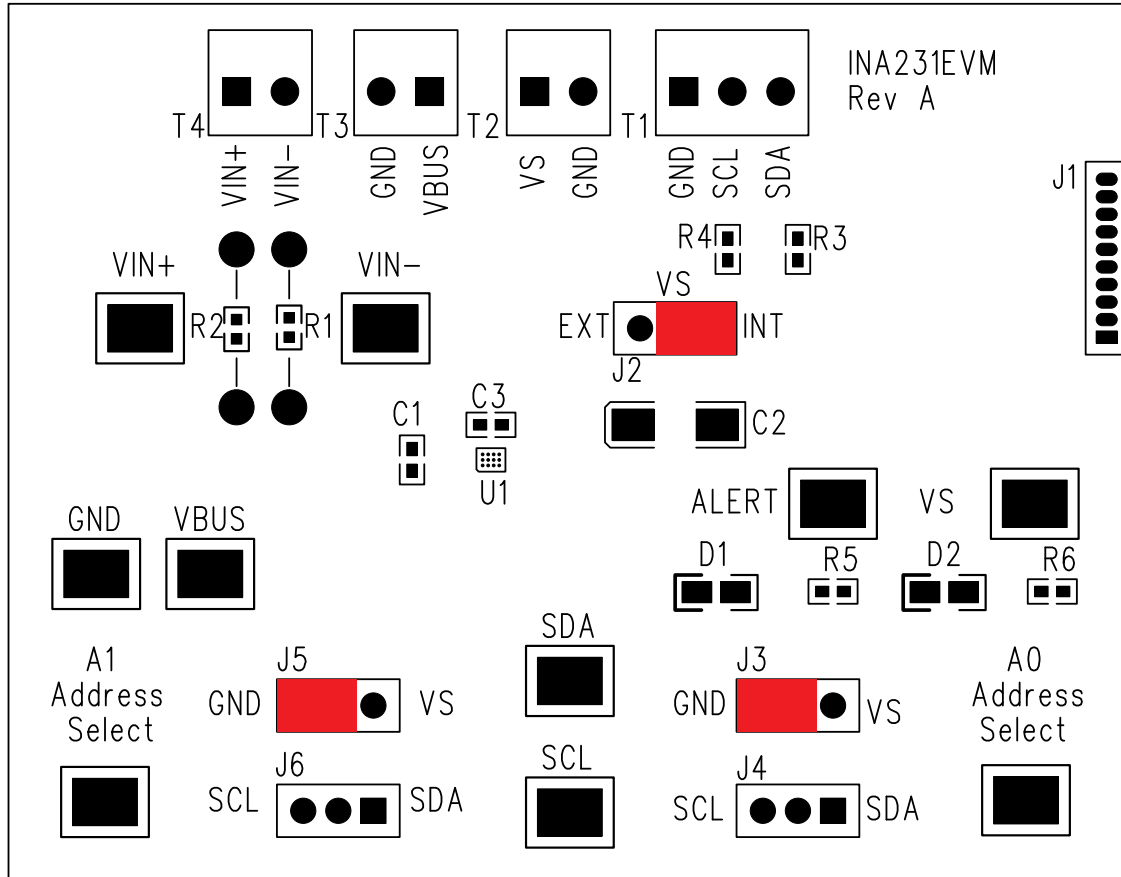

Figure 8. INA231EVM Default Jumper Settings

Typically, jumper 2 on the INA231EVM is always set to the INT position. When set to the INT position, the SM-USB-DIG Platform provides the supply for the INA231. When this jumper is set to the EXT position, an external supply voltage can be connected to terminal strip T2 to provide the supply for the INA231.

Jumpers 3 through 6 control the I²C address pins for the INA231. These jumpers can set the address for A0 and A1 to either supply, ground, SCL, or SDA. Make sure to only connect one jumper at a time for each address control. Failure to properly connect jumpers can cause shorts or interruptions in the communication lines. For more information on the INA231 addressing, refer to the [INA231 product data sheet](#).

Table 4 summarizes the function of the INA231 Test Board jumpers. For most applications, all jumpers should be left in the respective default configurations.

Table 4. INA231EVM Test Board Jumper Functions

Jumper	Default	Purpose
J2	INT	This jumper selects whether the V _S pin on the INA231 is connected to the V _{DUT} signal generated from the SM-USB-DIG Platform or whether the digital supply pin is connected to terminal T2, allowing for an external supply to power the device. The default INT position connects the V _S pin to the V _{DUT} control signal.
J3/J4	GND	This jumper selects the I ² C A0 address selection for A0.
J5/J6	GND	This jumper selects the I ² C A1 address selection for A1.

3.6 INA231EVM Features

This section describes some of the hardware features present on the INA231EVM test board.

3.6.1 J2: I²C V_S Control Setting

Jumper J2 selects what the INA231 supply pin is connected to. If J2 is set to the INT position, the V_S pin is connected to the switchable V_{DUT} signal generated from the SM-USB-DIG Platform. This voltage can be set to either 3.3 V or 5 V, depending on how it is configured in the software. While J4 is set in the INT position, the V_S Power button in the INA231EVM software is able to control whether the V_{DUT} supply voltage is turned on or off.

When J2 is set in the EXT position, an external supply connected to terminal T2 can be used to provide the supply voltage for the INA231.

3.6.2 J3 and J4: I²C Address Hardware Setting (A0)

Jumpers J3 and J4 are used to set the hardware setting for the A0 I²C address pin on the INA231. Using J3, the A0 address can be set to either a logic '1' or a logic '0'. Using J4, the A0 address can be set to either the SCL or SDA communication line. Make sure to only have either J3 or J4 connected individually; failure to keep these lines separate can lead to board shorts and problems with the I²C communication lines. See [Section 5.2.1](#) on how to configure the INA231EVM software to match the J3/J4 hardware setting.

3.6.3 J5 and J6: I²C Address Hardware Setting (A1)

Jumpers J5 and J6 are used to set the hardware setting for the A1 I²C address pin on the INA231. Using J3, the A1 address can be set to either a logic '1' or a logic '0'. Using J4, the A1 address can be set to either the SCL or SDA communication line. Make sure to only have either J5 or J6 connected individually; failure to keep these lines separate can lead to board shorts and problems with the I²C communication lines. See [Section 5.2.1](#) on how to configure the INA231EVM software to match the J5/J6 hardware setting.

3.6.4 External I²C Lines and Terminal Block T1

The I²C communication lines on the INA231EVM are tied to two sources: the internal I²C communication lines from the SM-USB-DIG and the terminal block T1. If the user wants to add external signals separate from the SM-USB-DIG, simply disconnect the SM-USB-DIG from the INA231EVM board and hook up the necessary SDA, SCL, and GND lines. Also, remember to apply an external supply to the lines that is compatible with the I²C communication device being used.

NOTE: Failure to disconnect the SM-USB-DIG while using external I²C communication can cause damage to the SM-USB-DIG or any external communication devices that are connected.

3.6.5 VIN+ and VIN- Input filter (R1, R2, and C1)

The INA231EVM has an optional input filter to remove high-frequency noise from the inputs VIN+ and VIN-. The default values for R1 and R2 are 0-Ω. Figure 9 shows the typical setup, which is recommended for basic INA231 evaluation.

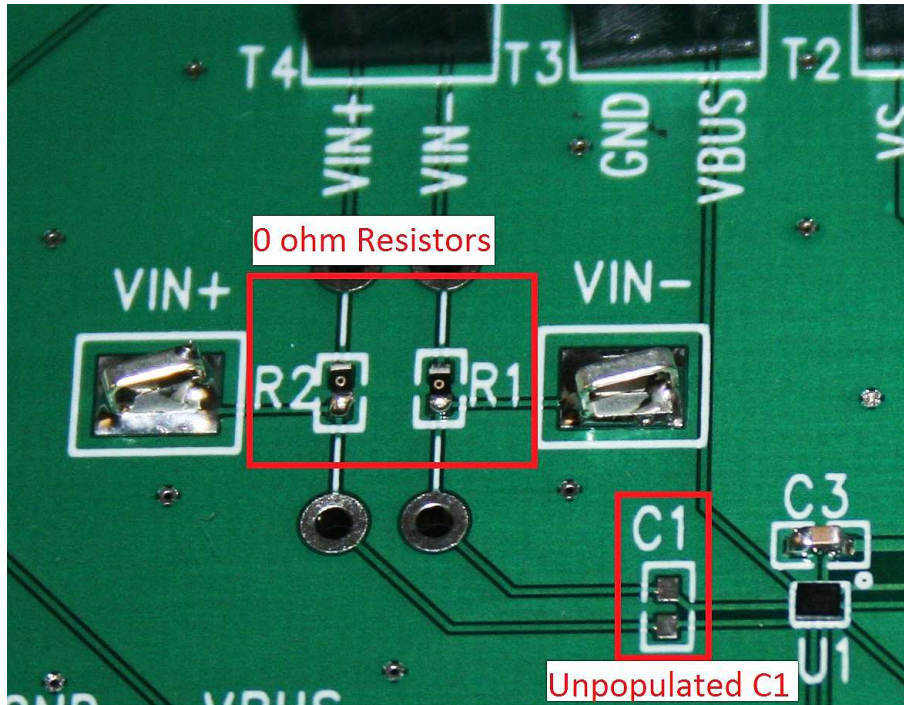

Figure 9. Typical Filter Setup

3.6.6 Shunt Monitor Configuration and Terminal Blocks T3 and T4

The INA231 is generally used in either a high-side or low-side shunt configuration, as shown in Figure 10. Terminal block T3 represents V_{BUS} and ground, while terminal block T4 represents VIN+ and VIN-. Depending on the user's needs, either of these configurations may be used without making any changes to the INA231EVM board or software.

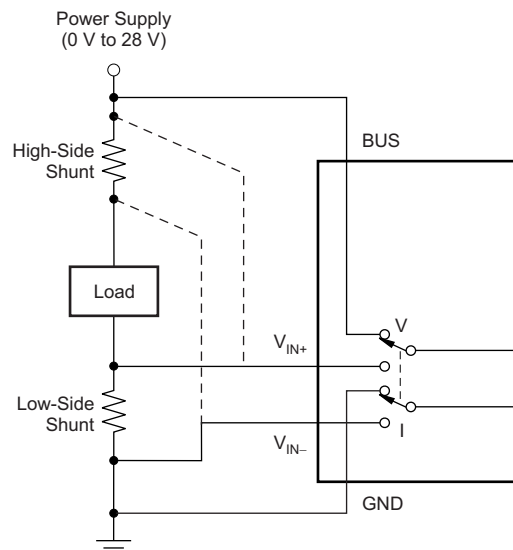

Figure 10. INA231 Shunt Configurations

4 INA231EVM Software Setup

This section discusses how to install the INA231EVM software.

4.1 Operating Systems for the INA231EVM Software

The INA231EVM software has been tested on Microsoft® Windows® XP operating systems (OS) with United States and European regional settings. The software should also function on other Windows OS platforms.

4.2 Software Installation

The INA231EVM software is included on the CD that is shipped with the EVM kit. It is also available through the [INA231EVM product folder](#) on www.ti.com. To install the software to a computer, insert the disc into an available CD-ROM drive. Navigate to the drive contents and open the INA231EVM software folder. Locate the compressed file (*INA231EVM.zip*) and open it using WinZIP® or a similar file compression program; extract the INA231EVM files into a specific INA231EVM folder (for example, *C:\INA231EVM*) on your hard drive.

Once the files are extracted, navigate to the INA231EVM folder you created on the hard drive. Locate the *setup.exe* file and execute it to start the installation. The INA231 software installer file then begins the installation process as shown in [Figure 11](#).

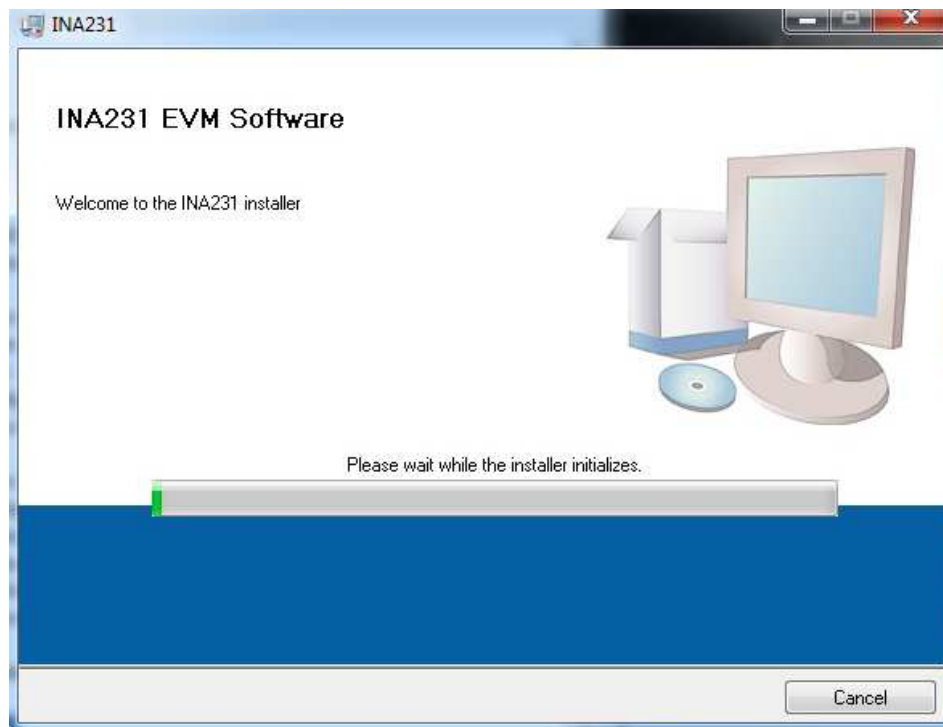

Figure 11. INA231EVM Software Installation

After the installation process initializes, the user is given the choice of selecting the directory in which to install the program; the default location is *C:\Program Files\INA231* and *C:\Program Files\National Instruments*. Following this option, two license agreements are presented that must be accepted, as shown in [Figure 12](#). After accepting the Texas Instruments and National Instruments license agreements, the progress bar opens and shows the installation of the software, as [Figure 13](#) illustrates. Once the installation process is completed, click **Finish**.

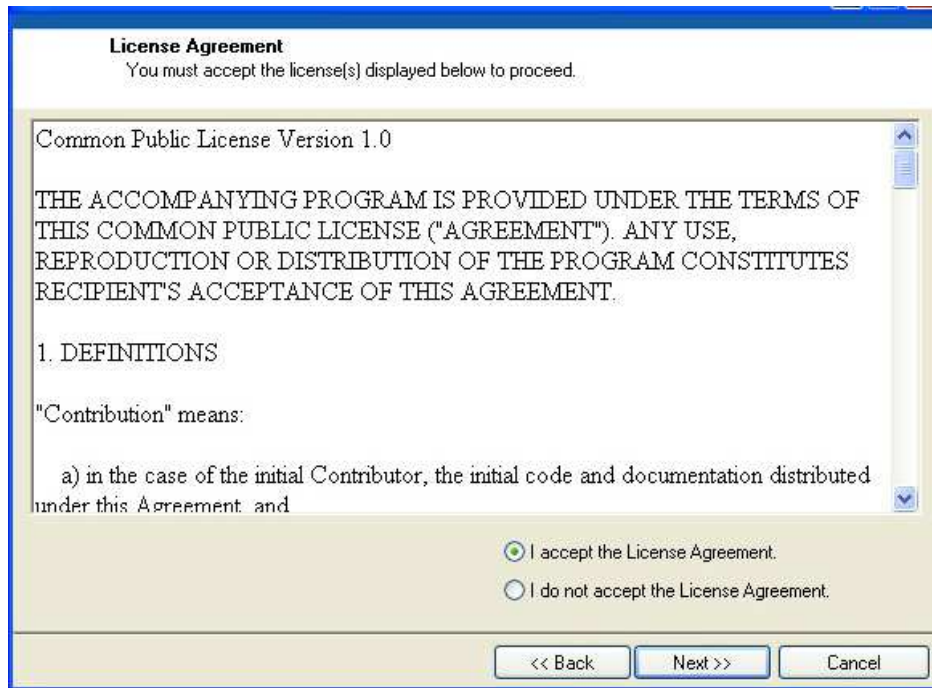

Figure 12. INA231EVM License Agreements

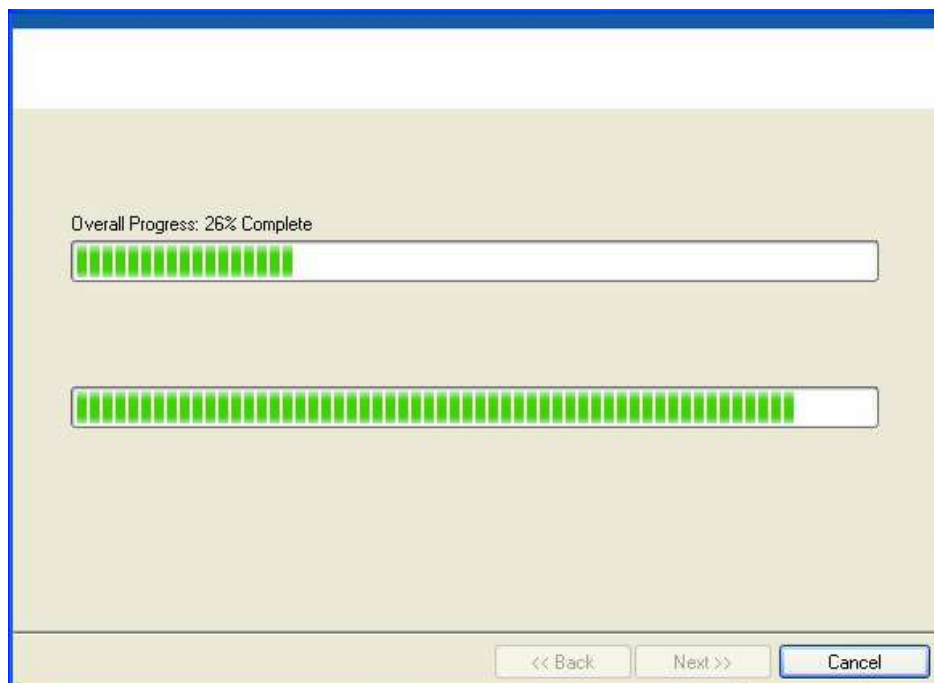

Figure 13. INA231EVM Software Installation Progress

5 INA231EVM Software Overview

This section discusses how to use the INA231EVM software. Software operation involves a two-step process: configuration of the INA231 settings, and operation of the tool.

5.1 Starting the INA231EVM Software

The INA231 software can be operated through the Windows *Start* menu. From *Start*, select *All Programs*; then select the *INA231EVM* program.

Figure 14 illustrates how the software should appear if the INA231EVM is functioning properly.

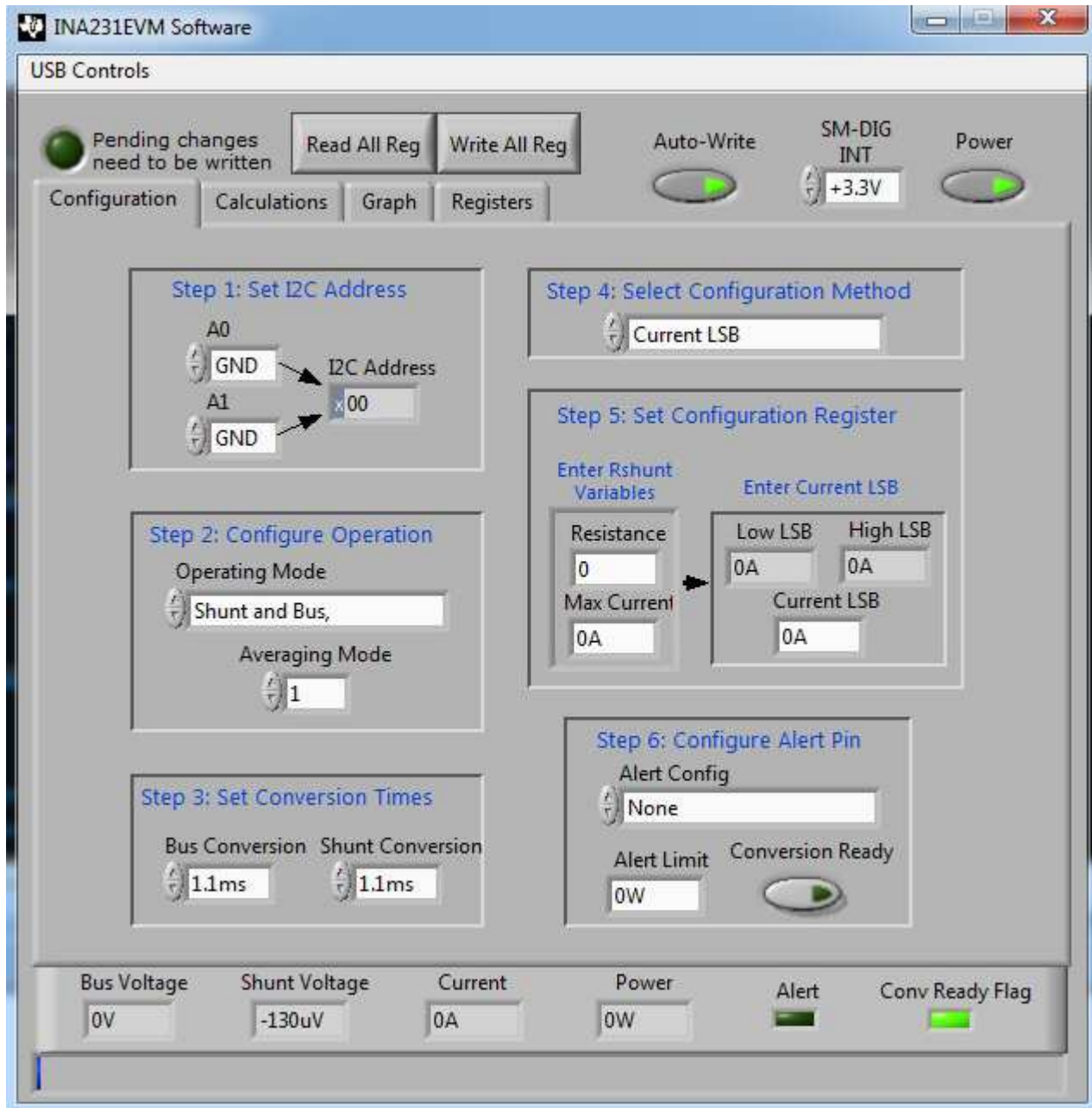

Figure 14. INA231EVM Software Interface

Figure 15 shows an error that pops up if the computer cannot communicate with the EVM. If you receive this error, first check to see that the USB cable is properly connected on both ends. This error can also occur if you connect the USB cable before the SM-USB-DIG Platform power source. Another possible source for this error is a problem with your PC USB Human Interface Device driver. Make sure that the device is recognized when the USB cable is plugged in; recognition is indicated by a Windows-generated confirmation sound.

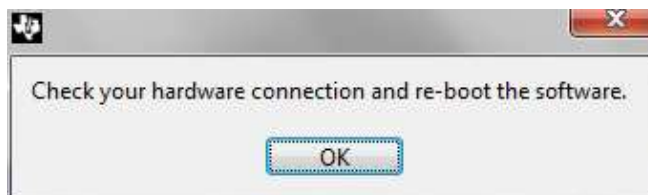

Figure 15. INA231EVM Software: Communication Error with the SM-USB-DIG Platform

5.2 Configuring the INA231EVM Software

The INA231EVM software first requires a series of setup processes to configure the device and ensure that it works properly. On the Configuration tab (see Figure 14), there are six steps noted:

- Step 1. Set I²C Address
- Step 2. Configure Operation
- Step 3. Set Conversion Times
- Step 4. Select Configuration Method
- Step 5. Set Configuration Register
- Step 6. Configure Alert Pin

This section explains how to configure the software and reviews some of the different setups that can be done.

5.2.1 I²C Address Selection

The INA231 device has a flexible I²C address configuration that allows for multiple devices to be on the same I²C lines. By moving the A0 and A1 addresses on jumpers J3-J6 to either GND, V_{S+}, SDA or SCL, the INA231 can be changed to a total of 16 I²C addresses as shown in Table 5.

Table 5. INA231 I²C Address Configuration

A1	A0	Slave Address
GND	GND	1000000
GND	V _{S+}	1000001
GND	SDA	1000010
GND	SCL	1000011
V _{S+}	GND	1000100
V _{S+}	V _{S+}	1000101
V _{S+}	SDA	1000110
V _{S+}	SCL	1000111
SDA	GND	1001000
SDA	V _{S+}	1001001
SDA	SDA	1001010
SDA	SCL	1001011
SCL	GND	1001100
SCL	V _{S+}	1001101
SCL	SDA	1001110
SCL	SCL	1001111

Figure 16 illustrates how to configure the I²C addresses. Click on either the A0 or A1 box and select how the hardware is configured on the EVM. Failure to select the correct address prevents the INA231 device from communicating with the software.

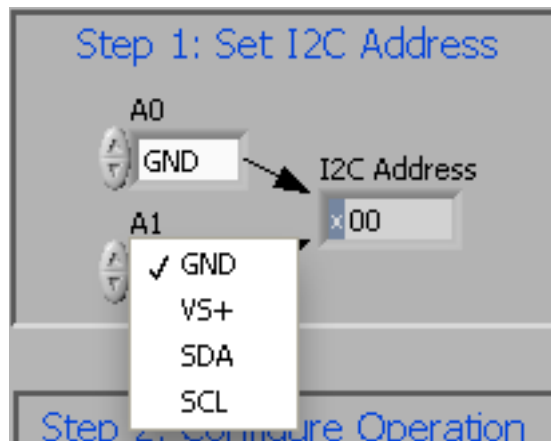

Figure 16. Setting the A1 Address

5.2.2 Configure Operating Mode

The second step of the INA231EVM configuration process allows the user to set the operating mode and the averaging mode.

The Operating mode allows the user to restrict the amount of calculations done within the INA231 by changing the conversion to be triggered or continuous, or shutting down the part altogether. When the device is operating in triggered mode, it only performs conversions when the operating mode is set and the *Write All Reg* button at the top of the screen is selected. After the mode changes and *Write All Reg* has been selected, the *Read All Reg* button must also be selected in order for the changes on the device to be reflected in the software.

When the INA231 is operating in continuous mode, conversions are performed directly after the previous conversion is completed. When the INA231EVM software is in continuous mode, the software can be updated at any time by pressing the *Read All Reg* button.

Power Down mode stops all conversions from taking place until the operating mode changes again. The device remains attached to power but draws minimal current and does not perform any conversions.

All three operating modes can also be limited to only measuring certain components of the device, as shown in [Figure 17](#). It is important to note that for complete functionality of the INA231, a configuration must be chosen with Shunt and Bus configuration. Failure to choose Shunt and Bus configuration disables a considerable portion of the unit functionality as discussed in the [INA231 data sheet](#).

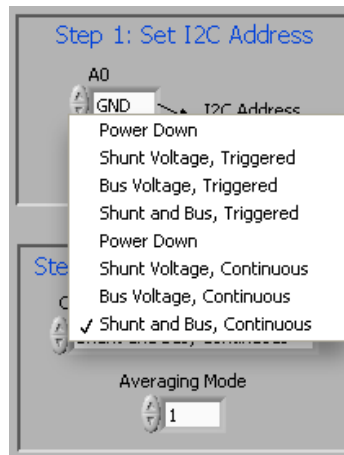

Figure 17. Configuring Operating Mode

The Configure Operation step also contains a drop down box for selecting the Averaging Mode. The INA231 can be setup to take the average of several measurements before storing the value of the measurements in the register table.

5.2.3 Set Conversion Times

Setting the conversion times allows the user to customize the amount of measurement time for conversions. Typically, for the INA231EVM software, the user is not able to notice a visual difference between the conversion times unless a high averaging mode and conversion time are chosen. The Shunt and Bus conversion times can be set as shown in [Figure 18](#).

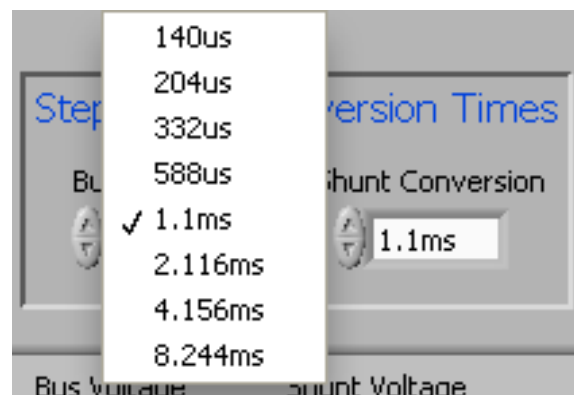

Figure 18. Configuring Conversion Times

5.2.4 Set Configuration Register

The Configuration Register must then be set correctly for the software to operate properly. There are two methods used to set the Configuration Register: first, the user can manually calculate the desired value and then input that value into the register table, as shown in Equation 1. Alternatively, the user can allow the software to create a recommended window and choose an LSB for the current as shown in Figure 20. Both methods accomplish the same goal by using Equation 1, but the method is selected by changing the value in Step 4: Select Configuration Method (as Figure 19 and Figure 20 show).

$$\text{Calibration Register} = \frac{0.00512}{\text{Current}_{\text{LSB}} \times R_{\text{SHUNT}}} \tag{1}$$

The current LSB is calculated by a recommended range in the INA231 data sheet as shown in Equation 2. It is important to note that with either of the methods used, the Current LSB and the Calibration Register values are calculated based on the other variable and the R_{SHUNT} value. See the section, *Programming the INA231* in the [product data sheet](#) for more information on setting the Calibration Register value.

$$\frac{\text{Max Expected Current}}{2^{15}} \leq \text{Current}_{\text{LSB}} \leq \frac{\text{Max Expected Current}}{2^{12}} \tag{2}$$

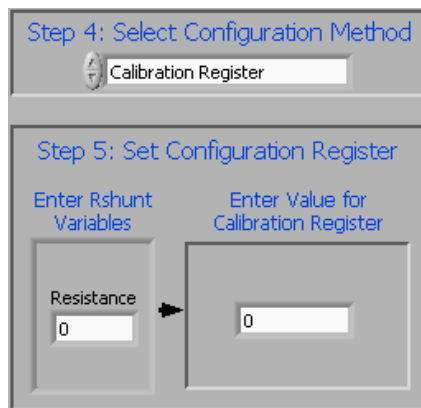

Figure 19. Setting the Configuration Register (Calibration Register)

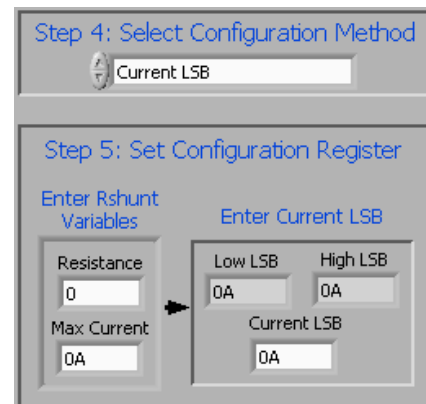

Figure 20. Setting the Configuration Register (Current LSB)

5.2.5 Configuring the Alert Pin

The Alert Pin from the INA231 allows the user to set limits that monitor the registers and trigger a flag when they are exceeded. The register that is being monitored can be changed by selecting the desired alert configuration as shown in Figure 21. The value that is being considered is compared to the *Alert Limit* box. This Alert Limit box modifies its functionality based on the selected configuration. It is important to note that by default, the INA231 Alert pin is set to active low.

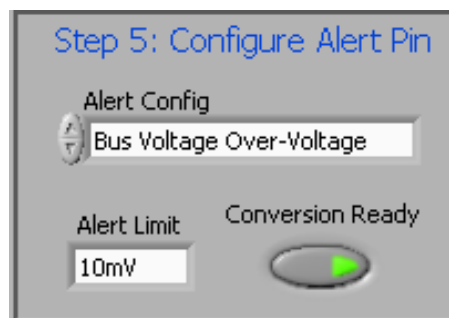

Figure 21. Configuring the Alert Pin

In addition to the INA231EVM software alert configuration, the Alert Configuration box includes the *Conversion Ready* button that allows for a special functionality on the Alert pin. When the INA231 completes the conversions for its current operation, it triggers the Alert pin and notifies the user that another conversion can be performed. In most cases, the INA231 conversion ready flag is not visible because of the speed of the INA231 conversion process.

5.3 Using the INA231EVM Software

After configuring the INA231EVM software, the rest of the tabs can be evaluated. This section describes the basic operation of the device, and offers guidelines for interpreting the graphic user interface (GUI).

5.3.1 INA231 Bus Voltage, Shunt Voltage, Current, and Power Reading Bar

The bottom bar of the INA231 software, as shown in [Figure 22](#), allows the user to constantly check the status of the INA231 unit itself. These values are updated each time the *Read All Reg* button is pressed at the top of the software. In addition to the register values stored in the part, the software also includes flags for when the part is ready to trigger another conversion and when the Alert pin is triggered.

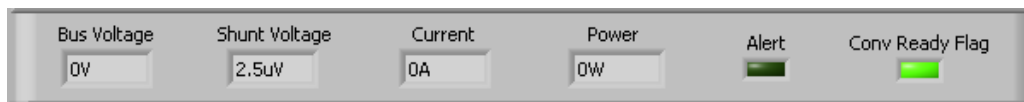

Figure 22. INA231 Results Bar

5.3.2 Calculation and Theory of Operation

The Calculation tab, as shown in [Figure 23](#), allows the user to follow the software flow with basic calculations performed from within the device. It is important to note that the calculations are performed with the decimal values of the corresponding registers.

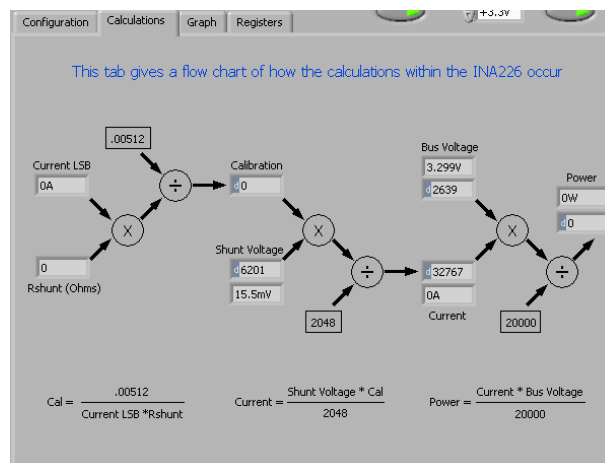

Figure 23. Theory of Operation Flowchart on the Calculation Tab

5.3.3 Register Tab

The Register tab contains information on the individual operation of the INA231 registers. Each register can be changed on a bit-by-bit basis to allow the user to have total control of the device beyond the general functionality of the GUI alone. Most of this functionality is displayed in the Configuration register tab, but by selecting the appropriate register and clicking on the *Help With Reg* button on the Register tab, as shown in Figure 24, the user can diagnose the individual uses of each bit in each register.

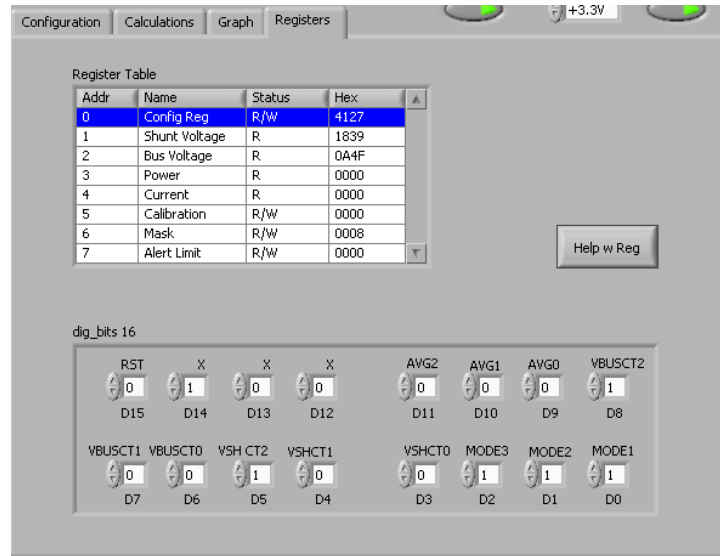

Figure 24. Registers Tab

5.3.4 Graph Tab

The Graph tab contains a plot window that shows the progression of data over time on the INA231. All four variables at the bottom of the EVM software (V_{BUS} , V_{SHUNT} , Current, and Power) can be plotted using the drop-down box directly above the graph. After the desired plot has been selected, toggle the *Continuously Poll Data* button above the plot to begin polling for data. If the user desires to save the data from the plot, simply select the *USB Controls* drop-down at the top of the page, then select the *Start Graph Log* option. Once the Start Graph Log has been selected, the user is prompted to select a location for the data and to name the file.

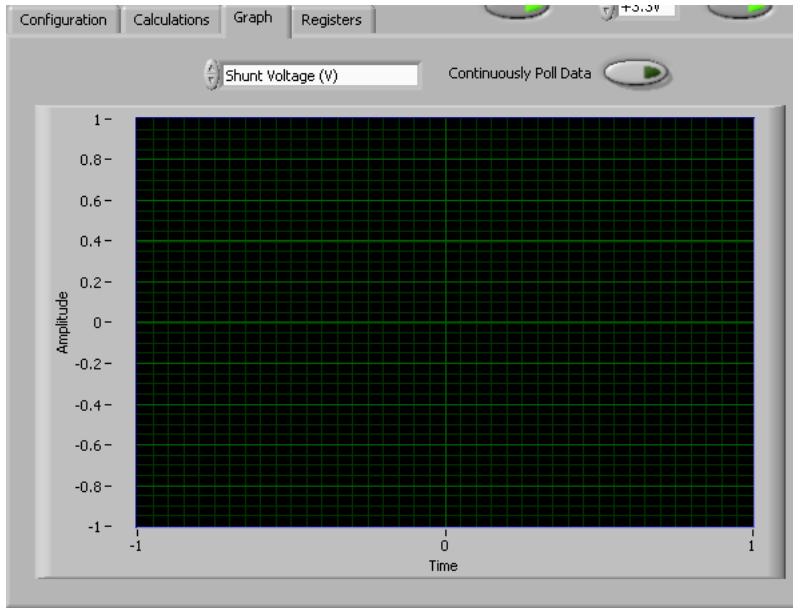

Figure 25. Graphing the INA231 Data

5.3.5 Auto-Write and the Supply Voltage

The INA231EVM software allows users to customize the board level voltage, regulated by the SM-USB-DIG. By selecting either 3.3 V or 5 V, the user can designate which voltage the device should operate at.

The software also includes an Auto-Write feature as shown in [Figure 26](#), which is enabled by default. This feature automatically updates the register table whenever a change is made. When this feature is enabled, the *Write All Registers* button serves little purpose and is only used as an alternative to when AutoWrite is disabled.



Figure 26. Auto-Write, Power Button, and Voltage Control

6 INA231EVM Documentation

This section contains the complete bill of materials, schematic diagram, and PCB layout for the INA231EVM.

NOTE: The board layout is not to scale. This image is intended to show how the board is laid out; it is not intended to be used for manufacturing INA231EVM PCBs.

6.1 Schematic

Figure 27 shows the schematic for the INA231EVM.

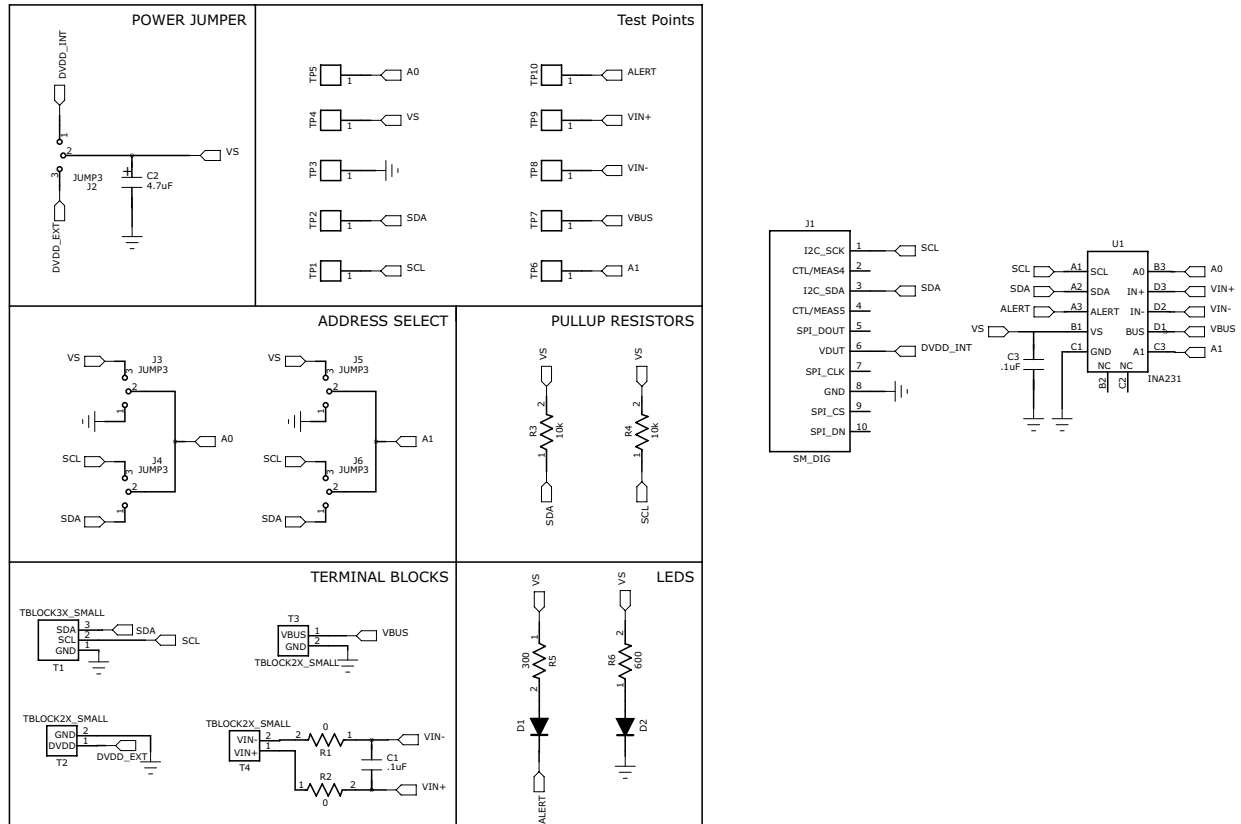

Figure 27. INA231EVM Schematic

6.2 PCB Layout

Figure 28 shows the component layout for the INA231EVM PCB.

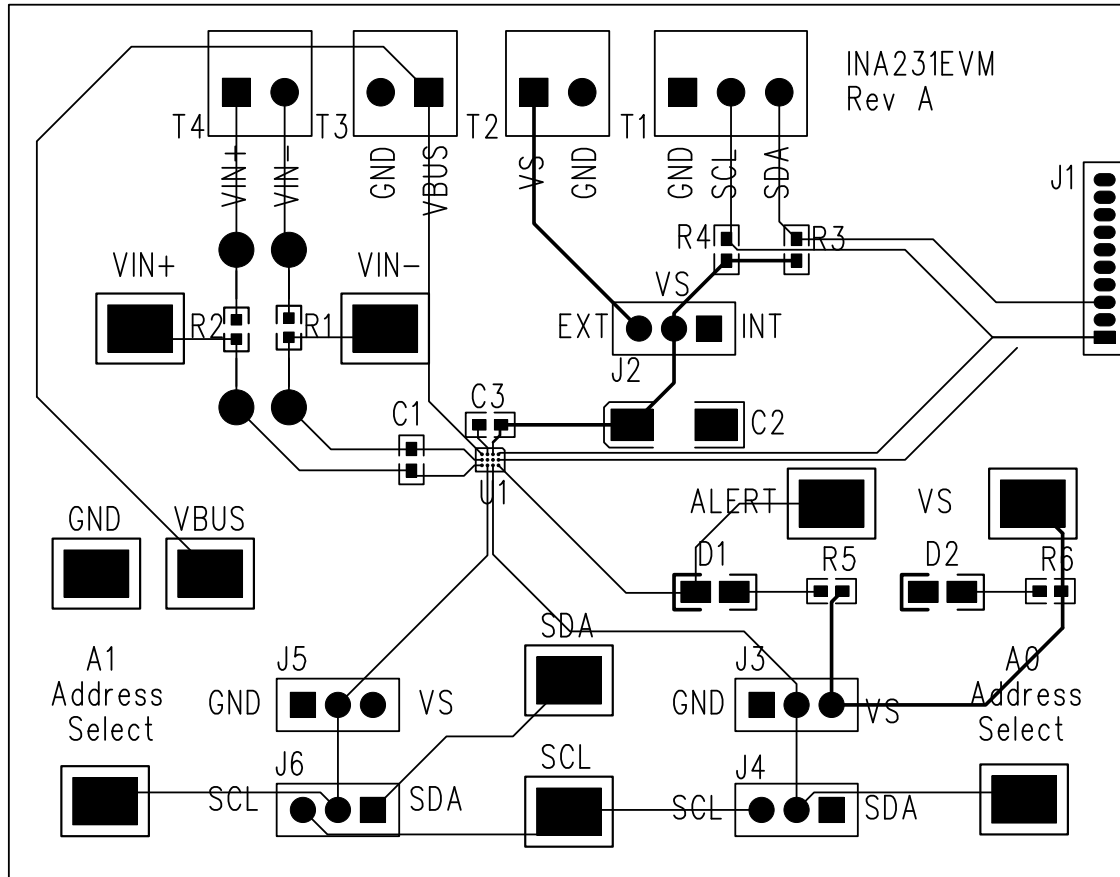

Figure 28. INA231EVM PCB Top Layer (Component Side)

6.3 Bill of Materials

Table 6 lists the bill of materials for the INA231EVM.

Table 6. Bill of Materials: INA231EVM

Item No.	Ref Des	Description	Vendor/Mfr	Part Number
1	R5, R6	Resistor, 10 k Ω 1/10 W 5% 0603 SMD	Stackpole Electronics	RMCF0603JT10K0
2	R3, R4	Resistor, 300 Ω 1/10 W 5% 0603 SMD	Panasonic	ERJ-3GEYJ301V
3	R1, R2	Resistor, 0.0 Ω 1/10 W 0603 SMD	Stackpole Electronics	RMCF0603ZT0R00
4	C2	Capacitor, Tantalum 4.7 μ F 35 V 10% SM	AVX Corp.	TAJC475K035RNJ
5	C3, C4	Capacitor, Ceramic 0.10 μ F 25 V X7R 10% 0603	TDK Corp.	C1608X7R1E104K
6	D1, D2	LED Green Wide Angle 0603 SMD	Panasonic	LNJ3W0C83RA
7	U1	INA231 Current Shunt Monitor	Texas Instruments	INA231AIYFF
8	Jumpers All	Connector, Header 50-Position .100" SGL Gold	Samtec	TSW-150-07-G-S
9	Jumpers All	Shunt LP w/Handle 2-Pos 30AU	Tyco Electronics	881545-2
10	Test Points All	PC Test Point Compact SMT	Keystone Electronics	5016
11	T1	3-Block Terminal 3.5 mm	On Shore Technology Inc	ED555/3DS
12	T2, T3, T4	2-Block Terminal 3.5 mm	On Shore Technology Inc	ED555/2DS
13	Bumpons	Bumpon Hemisphere 0.50 x 0.14 Clear	3M	SJ-5312 (CLEAR)
14	J1	Connector, Socket RT Angle 1-Position 0.050	Mill-Max Manufacturing	851-93-10-20-001000

EVALUATION BOARD/KIT/MODULE (EVM) ADDITIONAL TERMS

Texas Instruments (TI) provides the enclosed Evaluation Board/Kit/Module (EVM) under the following conditions:

The user assumes all responsibility and liability for proper and safe handling of the goods. Further, the user indemnifies TI from all claims arising from the handling or use of the goods.

Should this evaluation board/kit not meet the specifications indicated in the User's Guide, the board/kit may be returned within 30 days from the date of delivery for a full refund. THE FOREGOING LIMITED WARRANTY IS THE EXCLUSIVE WARRANTY MADE BY SELLER TO BUYER AND IS IN LIEU OF ALL OTHER WARRANTIES, EXPRESSED, IMPLIED, OR STATUTORY, INCLUDING ANY WARRANTY OF MERCHANTABILITY OR FITNESS FOR ANY PARTICULAR PURPOSE. EXCEPT TO THE EXTENT OF THE INDEMNITY SET FORTH ABOVE, NEITHER PARTY SHALL BE LIABLE TO THE OTHER FOR ANY INDIRECT, SPECIAL, INCIDENTAL, OR CONSEQUENTIAL DAMAGES.

Please read the User's Guide and, specifically, the Warnings and Restrictions notice in the User's Guide prior to handling the product. This notice contains important safety information about temperatures and voltages. For additional information on TI's environmental and/or safety programs, please visit www.ti.com/esh or contact TI.

No license is granted under any patent right or other intellectual property right of TI covering or relating to any machine, process, or combination in which such TI products or services might be or are used. TI currently deals with a variety of customers for products, and therefore our arrangement with the user is not exclusive. TI assumes no liability for applications assistance, customer product design, software performance, or infringement of patents or services described herein.

REGULATORY COMPLIANCE INFORMATION

As noted in the EVM User's Guide and/or EVM itself, this EVM and/or accompanying hardware may or may not be subject to the Federal Communications Commission (FCC) and Industry Canada (IC) rules.

For EVMs **not** subject to the above rules, this evaluation board/kit/module is intended for use for ENGINEERING DEVELOPMENT, DEMONSTRATION OR EVALUATION PURPOSES ONLY and is not considered by TI to be a finished end product fit for general consumer use. It generates, uses, and can radiate radio frequency energy and has not been tested for compliance with the limits of computing devices pursuant to part 15 of FCC or ICES-003 rules, which are designed to provide reasonable protection against radio frequency interference. Operation of the equipment may cause interference with radio communications, in which case the user at his own expense will be required to take whatever measures may be required to correct this interference.

General Statement for EVMs including a radio

User Power/Frequency Use Obligations: This radio is intended for development/professional use only in legally allocated frequency and power limits. Any use of radio frequencies and/or power availability of this EVM and its development application(s) must comply with local laws governing radio spectrum allocation and power limits for this evaluation module. It is the user's sole responsibility to only operate this radio in legally acceptable frequency space and within legally mandated power limitations. Any exceptions to this are strictly prohibited and unauthorized by Texas Instruments unless user has obtained appropriate experimental/development licenses from local regulatory authorities, which is responsibility of user including its acceptable authorization.

For EVMs annotated as FCC – FEDERAL COMMUNICATIONS COMMISSION Part 15 Compliant

Caution

This device complies with part 15 of the FCC Rules. Operation is subject to the following two conditions: (1) This device may not cause harmful interference, and (2) this device must accept any interference received, including interference that may cause undesired operation.

Changes or modifications not expressly approved by the party responsible for compliance could void the user's authority to operate the equipment.

FCC Interference Statement for Class A EVM devices

This equipment has been tested and found to comply with the limits for a Class A digital device, pursuant to part 15 of the FCC Rules. These limits are designed to provide reasonable protection against harmful interference when the equipment is operated in a commercial environment. This equipment generates, uses, and can radiate radio frequency energy and, if not installed and used in accordance with the instruction manual, may cause harmful interference to radio communications. Operation of this equipment in a residential area is likely to cause harmful interference in which case the user will be required to correct the interference at his own expense.

FCC Interference Statement for Class B EVM devices

This equipment has been tested and found to comply with the limits for a Class B digital device, pursuant to part 15 of the FCC Rules. These limits are designed to provide reasonable protection against harmful interference in a residential installation. This equipment generates, uses and can radiate radio frequency energy and, if not installed and used in accordance with the instructions, may cause harmful interference to radio communications. However, there is no guarantee that interference will not occur in a particular installation. If this equipment does cause harmful interference to radio or television reception, which can be determined by turning the equipment off and on, the user is encouraged to try to correct the interference by one or more of the following measures:

- Reorient or relocate the receiving antenna.
- Increase the separation between the equipment and receiver.
- Connect the equipment into an outlet on a circuit different from that to which the receiver is connected.
- Consult the dealer or an experienced radio/TV technician for help.

For EVMs annotated as IC – INDUSTRY CANADA Compliant

This Class A or B digital apparatus complies with Canadian ICES-003.

Changes or modifications not expressly approved by the party responsible for compliance could void the user's authority to operate the equipment.

Concerning EVMs including radio transmitters

This device complies with Industry Canada licence-exempt RSS standard(s). Operation is subject to the following two conditions: (1) this device may not cause interference, and (2) this device must accept any interference, including interference that may cause undesired operation of the device.

Concerning EVMs including detachable antennas

Under Industry Canada regulations, this radio transmitter may only operate using an antenna of a type and maximum (or lesser) gain approved for the transmitter by Industry Canada. To reduce potential radio interference to other users, the antenna type and its gain should be so chosen that the equivalent isotropically radiated power (e.i.r.p.) is not more than that necessary for successful communication.

This radio transmitter has been approved by Industry Canada to operate with the antenna types listed in the user guide with the maximum permissible gain and required antenna impedance for each antenna type indicated. Antenna types not included in this list, having a gain greater than the maximum gain indicated for that type, are strictly prohibited for use with this device.

Cet appareil numérique de la classe A ou B est conforme à la norme NMB-003 du Canada.

Les changements ou les modifications pas expressément approuvés par la partie responsable de la conformité ont pu vider l'autorité de l'utilisateur pour actionner l'équipement.

Concernant les EVMs avec appareils radio

Le présent appareil est conforme aux CNR d'Industrie Canada applicables aux appareils radio exempts de licence. L'exploitation est autorisée aux deux conditions suivantes : (1) l'appareil ne doit pas produire de brouillage, et (2) l'utilisateur de l'appareil doit accepter tout brouillage radioélectrique subi, même si le brouillage est susceptible d'en compromettre le fonctionnement.

Concernant les EVMs avec antennes détachables

Conformément à la réglementation d'Industrie Canada, le présent émetteur radio peut fonctionner avec une antenne d'un type et d'un gain maximal (ou inférieur) approuvé pour l'émetteur par Industrie Canada. Dans le but de réduire les risques de brouillage radioélectrique à l'intention des autres utilisateurs, il faut choisir le type d'antenne et son gain de sorte que la puissance isotrope rayonnée équivalente (p.i.r.e.) ne dépasse pas l'intensité nécessaire à l'établissement d'une communication satisfaisante.

Le présent émetteur radio a été approuvé par Industrie Canada pour fonctionner avec les types d'antenne énumérés dans le manuel d'usage et ayant un gain admissible maximal et l'impédance requise pour chaque type d'antenne. Les types d'antenne non inclus dans cette liste, ou dont le gain est supérieur au gain maximal indiqué, sont strictement interdits pour l'exploitation de l'émetteur.

【Important Notice for Users of this Product in Japan】

This development kit is NOT certified as Confirming to Technical Regulations of Radio Law of Japan

If you use this product in Japan, you are required by Radio Law of Japan to follow the instructions below with respect to this product:

1. Use this product in a shielded room or any other test facility as defined in the notification #173 issued by Ministry of Internal Affairs and Communications on March 28, 2006, based on Sub-section 1.1 of Article 6 of the Ministry's Rule for Enforcement of Radio Law of Japan,
2. Use this product only after you obtained the license of Test Radio Station as provided in Radio Law of Japan with respect to this product, or
3. Use of this product only after you obtained the Technical Regulations Conformity Certification as provided in Radio Law of Japan with respect to this product. Also, please do not transfer this product, unless you give the same notice above to the transferee. Please note that if you could not follow the instructions above, you will be subject to penalties of Radio Law of Japan.

Texas Instruments Japan Limited
(address) 24-1, Nishi-Shinjuku 6 chome, Shinjuku-ku, Tokyo, Japan

<http://www.tij.co.jp>

【ご使用にあたっての注】

本開発キットは技術基準適合証明を受けておりません。

本製品のご使用に際しては、電波法遵守のため、以下のいずれかの措置を取っていただく必要がありますのでご注意ください。

1. 電波法施行規則第6条第1項第1号に基づく平成18年3月28日総務省告示第173号で定められた電波暗室等の試験設備でご使用いただく。
2. 実験局の免許を取得後ご使用いただく。
3. 技術基準適合証明を取得後ご使用いただく。

なお、本製品は、上記の「ご使用にあたっての注意」を譲渡先、移転先に通知しない限り、譲渡、移転できないものとします。

上記を遵守頂けない場合は、電波法の罰則が適用される可能性があることをご留意ください。

日本テキサス・インスツルメンツ株式会社
東京都新宿区西新宿6丁目24番1号
西新宿三井ビル

<http://www.tij.co.jp>

EVALUATION BOARD/KIT/MODULE (EVM) WARNINGS, RESTRICTIONS AND DISCLAIMERS

For Feasibility Evaluation Only, in Laboratory/Development Environments. Unless otherwise indicated, this EVM is not a finished electrical equipment and not intended for consumer use. It is intended solely for use for preliminary feasibility evaluation in laboratory/development environments by technically qualified electronics experts who are familiar with the dangers and application risks associated with handling electrical mechanical components, systems and subsystems. It should not be used as all or part of a finished end product.

Your Sole Responsibility and Risk. You acknowledge, represent and agree that:

1. You have unique knowledge concerning Federal, State and local regulatory requirements (including but not limited to Food and Drug Administration regulations, if applicable) which relate to your products and which relate to your use (and/or that of your employees, affiliates, contractors or designees) of the EVM for evaluation, testing and other purposes.
2. You have full and exclusive responsibility to assure the safety and compliance of your products with all such laws and other applicable regulatory requirements, and also to assure the safety of any activities to be conducted by you and/or your employees, affiliates, contractors or designees, using the EVM. Further, you are responsible to assure that any interfaces (electronic and/or mechanical) between the EVM and any human body are designed with suitable isolation and means to safely limit accessible leakage currents to minimize the risk of electrical shock hazard.
3. You will employ reasonable safeguards to ensure that your use of the EVM will not result in any property damage, injury or death, even if the EVM should fail to perform as described or expected.
4. You will take care of proper disposal and recycling of the EVM's electronic components and packing materials.

Certain Instructions. It is important to operate this EVM within TI's recommended specifications and environmental considerations per the user guidelines. Exceeding the specified EVM ratings (including but not limited to input and output voltage, current, power, and environmental ranges) may cause property damage, personal injury or death. If there are questions concerning these ratings please contact a TI field representative prior to connecting interface electronics including input power and intended loads. Any loads applied outside of the specified output range may result in unintended and/or inaccurate operation and/or possible permanent damage to the EVM and/or interface electronics. Please consult the EVM User's Guide prior to connecting any load to the EVM output. If there is uncertainty as to the load specification, please contact a TI field representative. During normal operation, some circuit components may have case temperatures greater than 60°C as long as the input and output are maintained at a normal ambient operating temperature. These components include but are not limited to linear regulators, switching transistors, pass transistors, and current sense resistors which can be identified using the EVM schematic located in the EVM User's Guide. When placing measurement probes near these devices during normal operation, please be aware that these devices may be very warm to the touch. As with all electronic evaluation tools, only qualified personnel knowledgeable in electronic measurement and diagnostics normally found in development environments should use these EVMs.

Agreement to Defend, Indemnify and Hold Harmless. You agree to defend, indemnify and hold TI, its licensors and their representatives harmless from and against any and all claims, damages, losses, expenses, costs and liabilities (collectively, "Claims") arising out of or in connection with any use of the EVM that is not in accordance with the terms of the agreement. This obligation shall apply whether Claims arise under law of tort or contract or any other legal theory, and even if the EVM fails to perform as described or expected.

Safety-Critical or Life-Critical Applications. If you intend to evaluate the components for possible use in safety critical applications (such as life support) where a failure of the TI product would reasonably be expected to cause severe personal injury or death, such as devices which are classified as FDA Class III or similar classification, then you must specifically notify TI of such intent and enter into a separate Assurance and Indemnity Agreement.

Mailing Address: Texas Instruments, Post Office Box 655303, Dallas, Texas 75265
Copyright © 2013, Texas Instruments Incorporated

IMPORTANT NOTICE

Texas Instruments Incorporated and its subsidiaries (TI) reserve the right to make corrections, enhancements, improvements and other changes to its semiconductor products and services per JESD46, latest issue, and to discontinue any product or service per JESD48, latest issue. Buyers should obtain the latest relevant information before placing orders and should verify that such information is current and complete. All semiconductor products (also referred to herein as "components") are sold subject to TI's terms and conditions of sale supplied at the time of order acknowledgment.

TI warrants performance of its components to the specifications applicable at the time of sale, in accordance with the warranty in TI's terms and conditions of sale of semiconductor products. Testing and other quality control techniques are used to the extent TI deems necessary to support this warranty. Except where mandated by applicable law, testing of all parameters of each component is not necessarily performed.

TI assumes no liability for applications assistance or the design of Buyers' products. Buyers are responsible for their products and applications using TI components. To minimize the risks associated with Buyers' products and applications, Buyers should provide adequate design and operating safeguards.

TI does not warrant or represent that any license, either express or implied, is granted under any patent right, copyright, mask work right, or other intellectual property right relating to any combination, machine, or process in which TI components or services are used. Information published by TI regarding third-party products or services does not constitute a license to use such products or services or a warranty or endorsement thereof. Use of such information may require a license from a third party under the patents or other intellectual property of the third party, or a license from TI under the patents or other intellectual property of TI.

Reproduction of significant portions of TI information in TI data books or data sheets is permissible only if reproduction is without alteration and is accompanied by all associated warranties, conditions, limitations, and notices. TI is not responsible or liable for such altered documentation. Information of third parties may be subject to additional restrictions.

Resale of TI components or services with statements different from or beyond the parameters stated by TI for that component or service voids all express and any implied warranties for the associated TI component or service and is an unfair and deceptive business practice. TI is not responsible or liable for any such statements.

Buyer acknowledges and agrees that it is solely responsible for compliance with all legal, regulatory and safety-related requirements concerning its products, and any use of TI components in its applications, notwithstanding any applications-related information or support that may be provided by TI. Buyer represents and agrees that it has all the necessary expertise to create and implement safeguards which anticipate dangerous consequences of failures, monitor failures and their consequences, lessen the likelihood of failures that might cause harm and take appropriate remedial actions. Buyer will fully indemnify TI and its representatives against any damages arising out of the use of any TI components in safety-critical applications.

In some cases, TI components may be promoted specifically to facilitate safety-related applications. With such components, TI's goal is to help enable customers to design and create their own end-product solutions that meet applicable functional safety standards and requirements. Nonetheless, such components are subject to these terms.

No TI components are authorized for use in FDA Class III (or similar life-critical medical equipment) unless authorized officers of the parties have executed a special agreement specifically governing such use.

Only those TI components which TI has specifically designated as military grade or "enhanced plastic" are designed and intended for use in military/aerospace applications or environments. Buyer acknowledges and agrees that any military or aerospace use of TI components which have **not** been so designated is solely at the Buyer's risk, and that Buyer is solely responsible for compliance with all legal and regulatory requirements in connection with such use.

TI has specifically designated certain components as meeting ISO/TS16949 requirements, mainly for automotive use. In any case of use of non-designated products, TI will not be responsible for any failure to meet ISO/TS16949.

Products

Audio	www.ti.com/audio
Amplifiers	amplifier.ti.com
Data Converters	dataconverter.ti.com
DLP® Products	www.dlp.com
DSP	dsp.ti.com
Clocks and Timers	www.ti.com/clocks
Interface	interface.ti.com
Logic	logic.ti.com
Power Mgmt	power.ti.com
Microcontrollers	microcontroller.ti.com
RFID	www.ti-rfid.com
OMAP Applications Processors	www.ti.com/omap
Wireless Connectivity	www.ti.com/wirelessconnectivity

Applications

Automotive and Transportation	www.ti.com/automotive
Communications and Telecom	www.ti.com/communications
Computers and Peripherals	www.ti.com/computers
Consumer Electronics	www.ti.com/consumer-apps
Energy and Lighting	www.ti.com/energy
Industrial	www.ti.com/industrial
Medical	www.ti.com/medical
Security	www.ti.com/security
Space, Avionics and Defense	www.ti.com/space-avionics-defense
Video and Imaging	www.ti.com/video

TI E2E Community

e2e.ti.com