

Wedge Transponder

RI-TRP-R9BK

RI-TRP-W9WK

Reference Guide

December 2006

Wedge Transponder

RI-TRP-R9BK
RI-TRP-W9WK

Reference Guide



Literature Number: SCBU037

December 2006



Preface	5
1 Wedge Transponder	7
1.1 Introduction	7
1.2 Transponder Marking.....	8
1.3 Function	9
1.3.1 Read (Reading of RO and R/W Transponders)	9
1.3.2 Write and Program	11
1.4 Characteristics of the RFID System	13
1.4.1 Basic System Data	13
1.4.2 Reader and System Design Impact.....	13
1.4.3 System Performance and Functional Reliability Impact.....	13
1.4.4 Other Quality Factors	14
1.5 EMI/EMC Performance	14
1.5.1 General	14
1.5.2 Transponder and System Performance	14
1.6 Measurement Setups	16
1.6.1 Resonance Frequency, Bandwidth, and Quality Factor of Transponder.....	16
1.6.2 Powering Field Strength	18
1.6.3 Transponder Signal Strength	19
1.7 Absolute Maximum Ratings RI-TRP-W9WK.....	21
1.8 Absolute Maximum Ratings RI-TRP-R9BK	21
1.9 Recommended Operating Conditions	21
1.10 Characteristics	22
1.11 Environmental Data and Reliability	22
1.12 Memory	22
1.13 Package	23
1.14 Conversion Formula	24

List of Figures

1-1	System Configuration Showing the Reader, Antenna, and Transponder	7
1-2	Block Diagram of the Transponder	7
1-3	Dimensions of the Wedge Transponder (in mm)	9
1-4	Charge and Read Function of the Transponder, Showing the Voltage at the Transponder and Reader Coil .	10
1-5	FM Principle Used for the Read Function of Transponders	11
1-6	Read Data Format of RO Transponder	11
1-7	Read Data Format of R/W Transponder	11
1-8	Charge, Write and Program Principle Used, Showing the Voltage at the Reader and Transponder Antenna Coil	12
1-9	The Write and Program Function	12
1-10	Write Data Format for Programming Function	13
1-11	EMI Performance Test of the System	15
1-12	EMI Performance at Commonly Used Radio Communication Frequencies	15
1-13	Reading Range Under Broad Band Noise (White Noise) Conditions	16
1-14	Measurement Setup for the Determination of Transponder Resonance Frequency, Bandwidth and Quality Factor	17
1-15	Determination of the Resonance Frequency and –3 dB Bandwidth by Monitoring the Pickup Coil Voltage ...	17
1-16	Test Setup for Powering Field Strength Determination	18
1-17	Received Signal at the Pickup Coil, if Power Field Strength Is Sufficient	19
1-18	Determination of the Transponder Signal Strength (Data Transmission Signal Strength) With Helmholtz Aperture	19
1-19	Monitored Signal Voltage at the Spectrum Analyzer (Time Domain Mode)	20

Read This First

Purpose

This document is the Reference Manual for the Wedge Transponder. Its purpose is to support customers who wish to use the transponder in Radio Frequency Identification (RFID) installations by providing technical information concerning function, performance, application, and environment-related parameters.

Scope

This Reference Manual covers the following devices:

- RI-TRP-R9BK
- RI-TRP-W9WK

References

There are currently no other documents referenced herein.

Responsibilities

The RFID Product Marketing Manager or his designee is responsible for maintaining this document.

About This Guide

This document is the Reference Manual for the Wedge Transponder. Its purpose is to support customers who wish to use the transponder in Radio Frequency Identification (RFID) installations by providing technical information concerning function, performance, application, and environment-related parameters.

Conventions

WARNING

A WARNING IS USED WHERE CARE MUST BE TAKEN, OR A CERTAIN PROCEDURE MUST BE FOLLOWED IN ORDER TO PREVENT INJURY OR HARM TO YOUR HEALTH.

CAUTION

This indicates information on conditions which must be met, or a procedure which must be followed, which if not heeded could cause permanent damage to the equipment or software.

Note: Indicates conditions which must be met, or procedures which must be followed, to ensure proper functioning of the equipment or software.

Also indicates information which makes usage of the equipment or software easier.

If You Need Assistance

Application Centers are located in Europe, North and South America, the Far East and Australia to provide direct support. For more information, please contact your nearest TI-RFid™ Sales and Application Center. The contact addresses can be found on our home page: <http://www.ti-rfid.com>

Trademarks

TIRIS, TI-RFid, and Tag-it are trademarks of Texas Instruments.

Wedge Transponder

1.1 Introduction

The Transponder in a wedge shape package is a key product in low frequency RFID systems that can be used for a variety of applications, such as automotive security systems.

The device is available in Read Only (RO) and Read/Write (R/W) versions. Electro Magnetic signals are used to power the passive (battery less) device, to transmit the identification number to a reader unit or to program the device with new data. The basic principle is described in [Figure 1-1](#).

Both RO and R/W versions use an 80 bit non-volatile memory (EEPROM) for storage of 64 identification bits and a 16 bit Block Check Character (BCC). The RO type is factory programmed with a unique tamperproof code that cannot be altered. The R/W version can be programmed by the user.

The Wedge Transponder comprises a ferrite core antenna, a charge capacitor, and the integrated circuit ([Figure 1-2](#)). The antenna inductance and an on-chip capacitor form a high quality resonant circuit. The components are enclosed in a plastic housing.

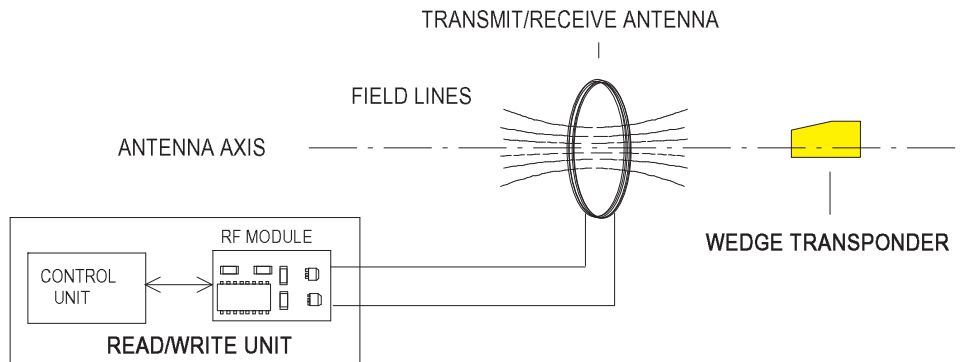

Figure 1-1. System Configuration Showing the Reader, Antenna, and Transponder

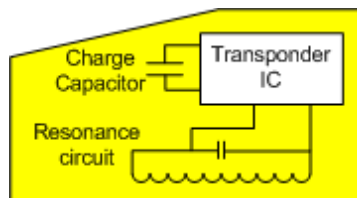

Figure 1-2. Block Diagram of the Transponder

1.2 Transponder Marking

The dimensions of the transponder are given in [Figure 1-3](#). The transponder housing material is IC mold compound. Notches allow the fixation of clips to assist in mounting or the addition of second packaging.

The wedge shape offers several advantages:

- It minimizes the total size of the transponder for easy integration into secondary packages.
- It provides a physical indication of the orientation of the antenna within the transponder to ensure correct antenna orientation at integration.
- It supports the ability to randomly pack transponders for the shipping process, thus reducing overall costs.

Figure 3 shows the dimensions of the transponder and the orientation of the antenna axis to ensure optimal coupling to the transmit/receive antenna of the transceiver unit.

The following product codes have been assigned to the Wedge Transponder:

- 64 bit Read Only device: RI-TRP-R9BK
- 64 bit Read/Write device: RI-TRP-W9WK

The Read/Write version of the Wedge Transponder (product code RI-TRP-W9WK) will be marked with an abbreviated product code according to the following scheme:

Product Code:	RI-TRP-W9WK-	
	xz	
Marking:	W-xzwwy	
Where:	xz	is the Product Revision
	ww	is the Production Week coding
	y	is the Production Year coding
Example:	Product	RI-TRP-W9WK-03 produced in week 2, 2004
	Marking:	W-03024

Note: The Read only version of the Wedge Transponder (product code RI-TRP-R9BK) will be supplied unmarked.

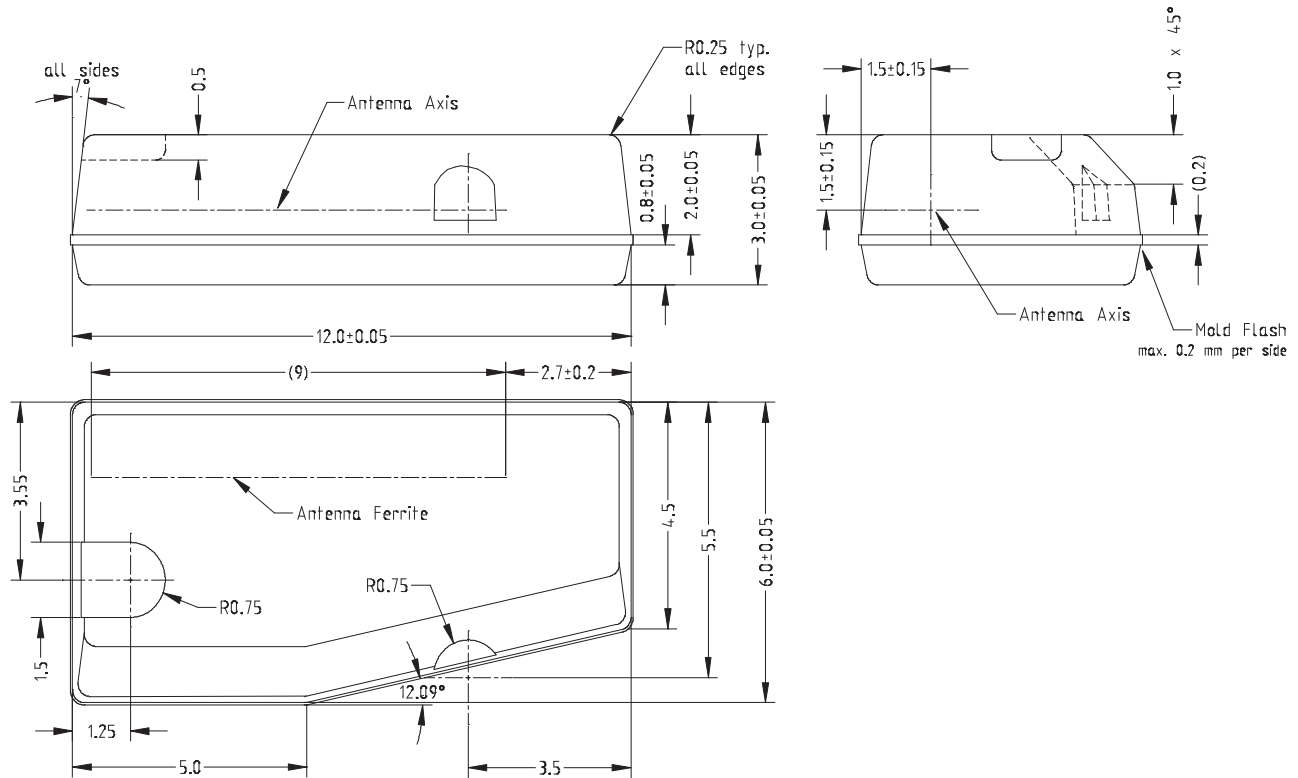

If not otherwise noted tolerance according DIN ISO 2768 m:
 Nominal dimension up to 6 mm: ± 0.1 mm
 Nominal dimension 6 up to 30 mm: ± 0.2 mm
 Nominal angle: $\pm 1^\circ$

Figure 1-3. Dimensions of the Wedge Transponder (in mm)

1.3 Function

The system uses a sequential function principle also called HDX (Half Duplex) separating the transponder powering (charge) and transponder data transmission mode. The advantages of the sequential mode are described in Section 1.4.1 Basic System Data.

1.3.1 Read (Reading of RO and R/W Transponders)

During the charge (or powering phase) of between 15 and 50 ms the interrogator generates an electromagnetic field using a frequency of 134.2 kHz. The resonant circuit of the transponder is energized and the induced voltage is rectified by the integrated circuit to charge the capacitor. The transponder detects the end of the charge burst and transmits its data using frequency shift keying (FSK), utilizing the energy stored in the capacitor.

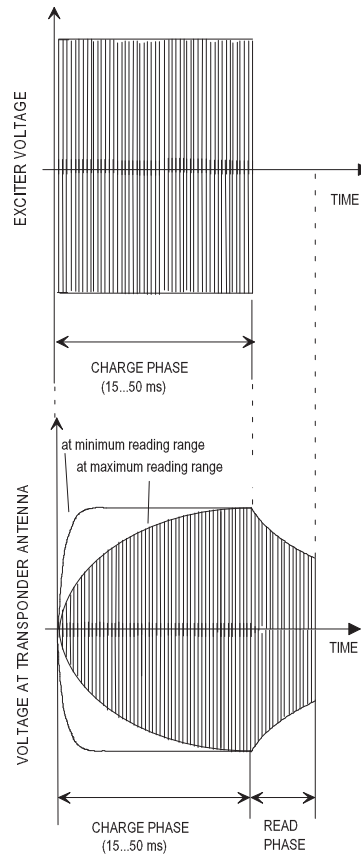

Figure 1-4. Charge and Read Function of the Transponder, Showing the Voltage at the Transponder and Reader Coil

The typical data low bit frequency is 134.7 kHz, the typical data high bit frequency is 123.7 kHz. The low and high bits have different durations, because each bit takes 16 RF cycles to transmit. The high bit has a typical duration of 129.3 μ s, the low bit of 118.8 μ s. [Figure 1-5](#) shows FM principle used. Regardless of the number of low and high bits, the transponder response duration is always less than 20 ms.

The data format consists of 128 bits. Different start/stop bytes and end bits are used, to allow secure distinction between RO and R/W Transponder. [Figure 1-6](#) and [Figure 1-7](#) show the format of the received data for RO and R/W transponders.

After transmission of the data format the capacitor is discharged. The typical transponder readout timing is described in [Figure 1-4](#). The charge phase is followed directly by the read phase (RO mode).

Data encoding is done in NRZ mode (Non Return to Zero). The clock is derived from the RF carrier by a divide-by-16 function.

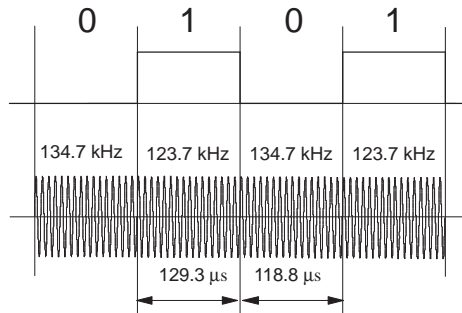

Figure 1-5. FM Principle Used for the Read Function of Transponders

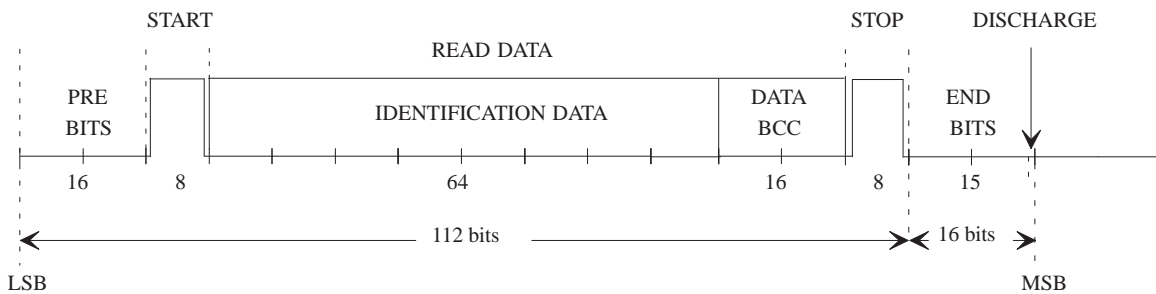

Figure 1-6. Read Data Format of RO Transponder

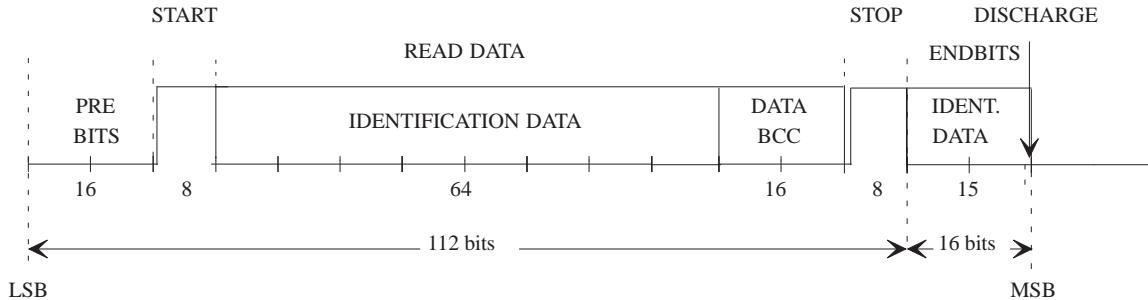

Figure 1-7. Read Data Format of R/W Transponder

1.3.2 Write and Program

A new identification number can be written (programmed) into a R/W transponders in the following manner: After the charge phase the R/W transponder enters the write mode providing the reader starts to modulate the field by switching the transmitter on and off (TXCT-). Modulation index of this amplitude modulation is 100%. The duration of the off-phase defines whether a low bit or a high bit is being transmitted (Pulse Width Modulation). Writing means, the transponder shifts the received bits into a shift register. After the write phase the reader's transmitter is switched on for a certain time (programming time) in order to energize the process of programming the shift register data into the EEPROM. All 80 bits are programmed simultaneously into the EEPROM. Once the data is programmed into the EEPROM the transponder automatically sends back the captured data to the reader to allow a security check, this process takes place when the transmitter is switched off. Each read unit can be used as a write unit through software change only. No hardware changes are required.

Function

Figure 1-8 describes the write function by showing the transmitter (reader) RF output signal and the transponder RF input signal. Figure 1-9 shows the TXCT- signal of the reader (transmitter) during the write and program function. The data transmission format of the write mode is described in Figure 1-10.

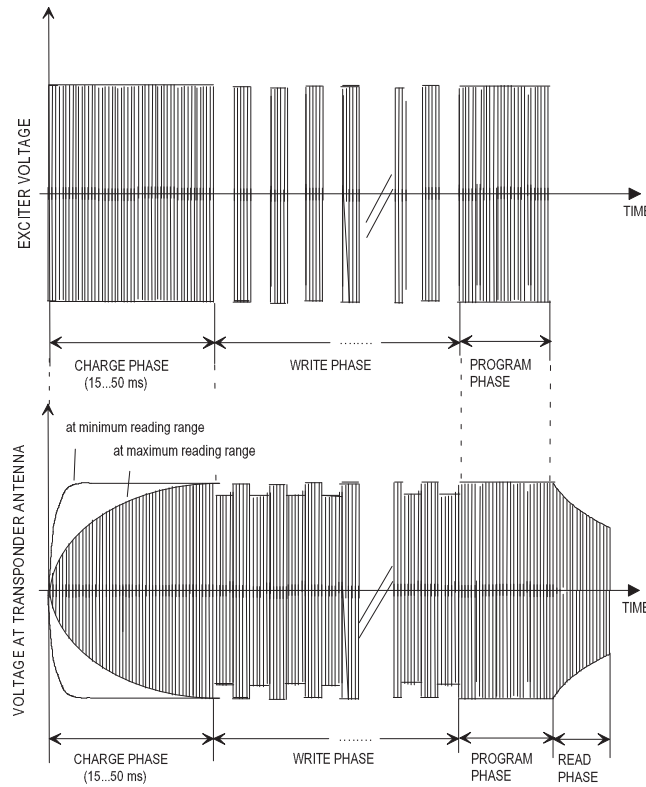

- Charge: Continuous RF Module transmitter output signal
- Write: Pulse width modulation of the RF module transmitter output signal
- Program: Continuous RF module transmitter output signal
- Read: Frequency Shift Keying of the transponder resonant circuit oscillation

Figure 1-8. Charge, Write and Program Principle Used, Showing the Voltage at the Reader and Transponder Antenna Coil

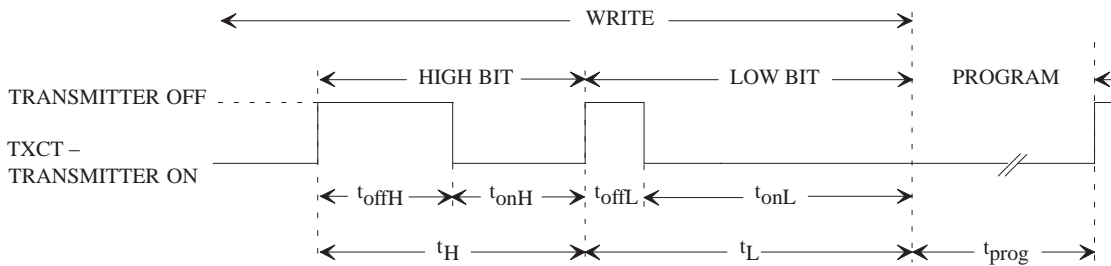

Figure 1-9. The Write and Program Function

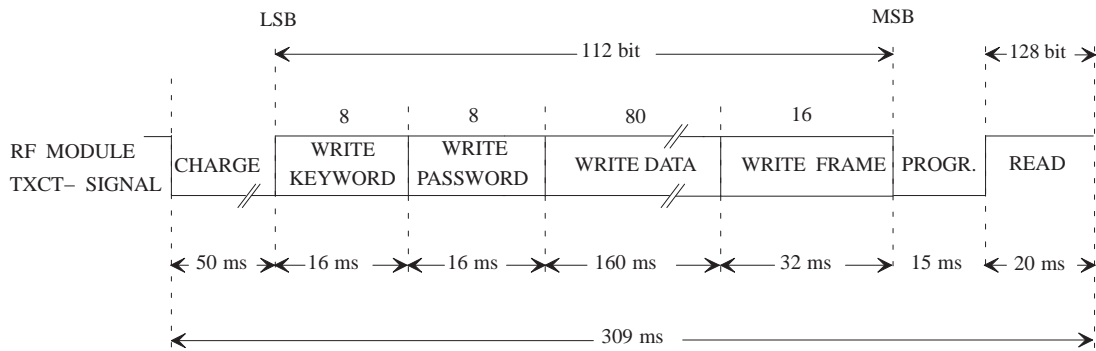

Figure 1-10. Write Data Format for Programming Function

1.4 Characteristics of the RFID System

1.4.1 Basic System Data

The system multiplexes the power and read functions avoiding compromises. This results in the following characteristics and options:

- Individual optimization of the power and read functions by the system designer.
- Variation of powering time by S/W to trade-off speed/current consumption with other parameters
- Absence of the high powering signal during the data reception phase
- Data transmission by an active oscillator. This is associated with a high signal strength level and high transponder efficiency.
- Transponder has an on-chip resonance capacitor.
- NRZ modulation encoding for high data speed and low transmission bandwidth.

1.4.2 Reader and System Design Impact

- Ease of receiver and power function design and the optimization of performance due to sequential power/read functions.
- Low field strength for transponder charge, resulting in lower cost of the power function.
- Optional performance and cost trade-offs by variation of:
 - Interrogation speed by S/W down to 35 ms.
 - Component selection to achieve different EMI performance levels.

1.4.3 System Performance and Functional Reliability Impact

- Inherent EMI robustness and high system Signal/Noise ratio because:
 - A. The transponder emits 6.20 dB higher data signal (compared to conventional systems).
 - B. The powering phase is noise immune and the data transmission phase duration is typically 16 ms.
 - C. FSK and NRZ allow a high data rate (typically 9 kbit/s).
 - D. Modulation is direct carrier FSK which has inherent AM noise suppression.
- Low reader power dissipation because of low charge field strength.
- Low power consumption due to pulsed operation (= low peak power x low duty cycle).
- Data telegram transmission is secured by 16 bit CRC-CCITT error detection protocol.
- The receive time is short, because the transponder protocol always starts at the beginning of the data stream. Therefore read repetitions are not necessary.

1.4.4 Other Quality Factors

- High and consistent transponder product quality and performance.
- The direct FSK provides enhanced separation and better position-selective reading of adjacent transponders compared to AM systems.
- Product migration path concept from RO to R/W to Password protected and Multipage transponders. The reader or system can be changed from RO to R/W by S/W change only.
- Transponders are 100% tested according to the procedures of TI's Total Quality Culture.

1.5 EMI/EMC Performance

1.5.1 General

For any given RF-ID system, the EMI/EMC performance is determined by three factors:

1. The reader design and the resulting noise immunity performance
2. The signal strength of the transponder and Signal/Noise ratio at the receiver input
3. The transponder immunity to EM fields:
 - The most critical EMI factor or component in a system is the reader immunity.
 - A high transponder data signal facilitates reader design through the higher Signal/Noise ratio.
 - The least critical component is the transponder. Immunity levels are generally very high.

All EMI sources can be classified into three different categories:

- Broad band industrial noise of sporadic or continuous nature
- Discrete radio frequency signals unmodulated or FM /FSK modulated
- Discrete radio frequency signals which are AM or ASK modulated.

1.5.2 Transponder and System Performance

EMI measurement procedures which are most currently cited (for example the DIN40839/part4) are inappropriate to:

- Determine a realistic RF-ID system behavior for an industrial environment
- Determine the EMI performance and threshold of transponder
- Test systems at worst case (low frequency) conditions.

However the transponder meets and exceeds the DIN40839/part4.

The system performance using reader and wedge transponder is shown in [Figure 1-11](#), [Figure 1-12](#) and [Figure 1-13](#).

[Figure 1-11](#) shows the system immunity over a spectrum of 6 decades. At the most critical Radio Short Wave Broadcast frequencies 400 V/m were encountered.

[Figure 1-12](#) highlights the system performance simulating RF communication conditions.

[Figure 1-13](#) shows the performance (reading range) under induced broad band noise (white noise) conditions.

1.5.2.1 EMI System Performance

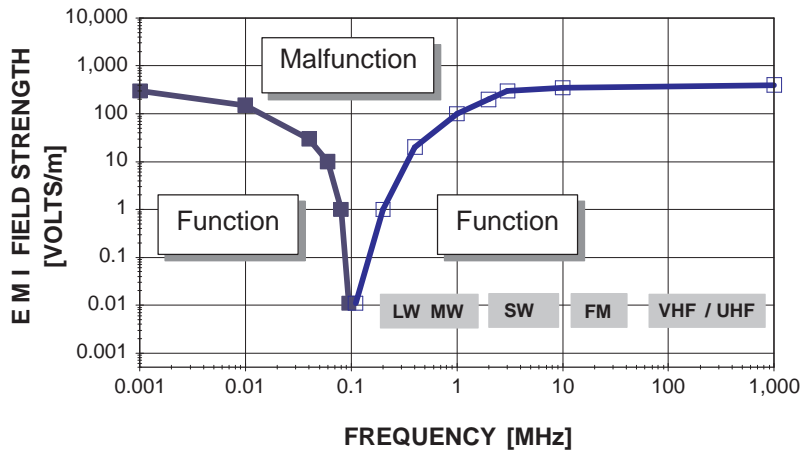

Figure 1-11. EMI Performance Test of the System

The graph shows the EM Immunity level in V/m as function of the frequency range from 1 kHz to 1000 MHz. Measurement condition: minimum 90% read probability at maximum read range using a standard reader.

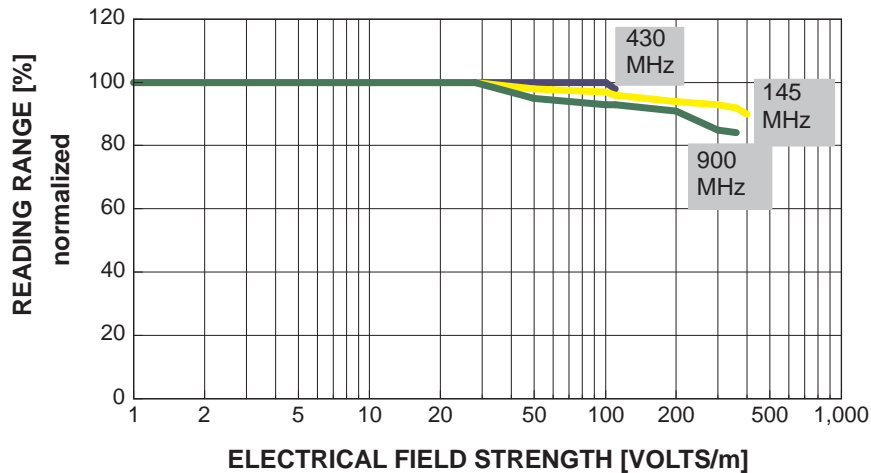

Figure 1-12. EMI Performance at Commonly Used Radio Communication Frequencies

1.5.2.2 White Noise Performance

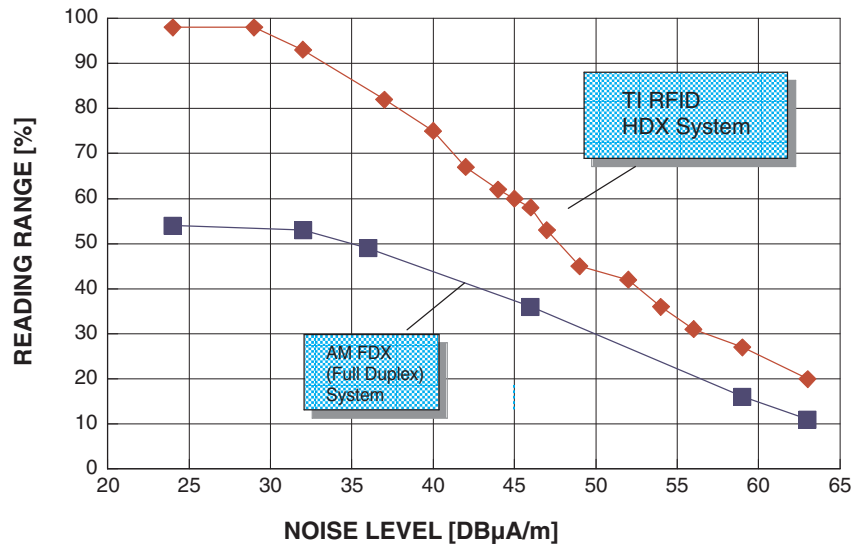

Figure 1-13. Reading Range Under Broad Band Noise (White Noise) Conditions

1.6 Measurement Setups

This section describes typical measurement set-ups to determine transponder relevant data like: resonant frequency, bandwidth, quality factor, powering field strength and transponder signal field strength as listed in Section 1.9 Recommended Operating Conditions.

1.6.1 Resonance Frequency, Bandwidth, and Quality Factor of Transponder

This test set-up is suitable for resonant frequency (f_{res}) measurements as well as the determination of the -3dB bandwidth (Δf) of the transponder. The quality factor Q of the transponder resonance circuit can be calculated with Equation 1-1:

$$Q = \frac{f_{res}}{\Delta f} \tag{1-1}$$

The wires of the pick-up coil should be very thin to avoid influence on the measurement results (for example: by damping). The choice of a $1\text{ M}\Omega$ input resistor at the spectrum analyzer is recommended. Figure 1-14 shows the test set-up. The relation between pick-up coil voltage and frequency is shown in Figure 1-15.

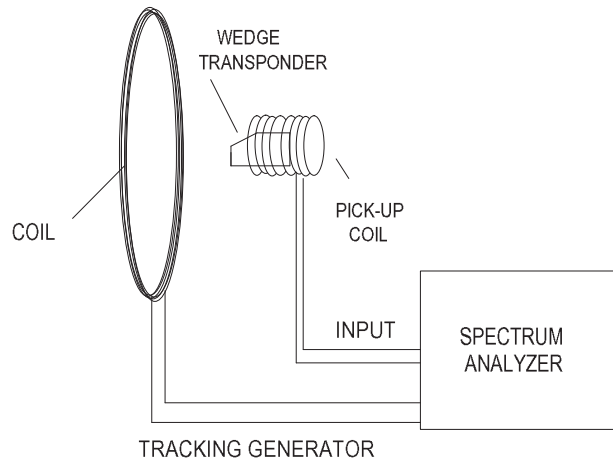

Figure 1-14. Measurement Setup for the Determination of Transponder Resonance Frequency, Bandwidth and Quality Factor

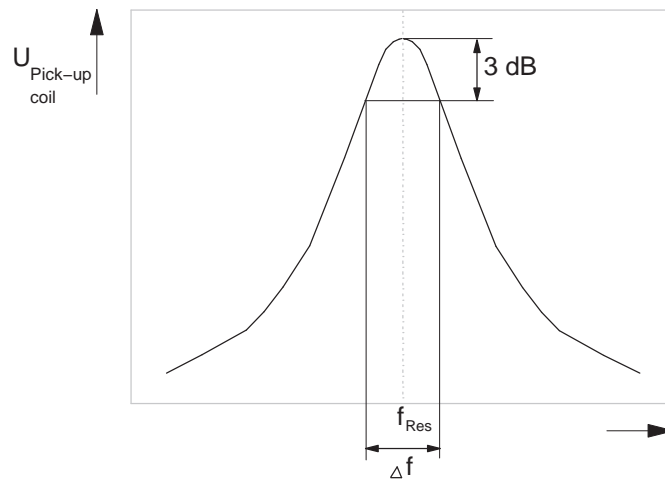

Figure 1-15. Determination of the Resonance Frequency and -3 dB Bandwidth by Monitoring the Pickup Coil Voltage

1.6.2 Powering Field Strength

The following set-up is used to determine the minimum required powering field strength.

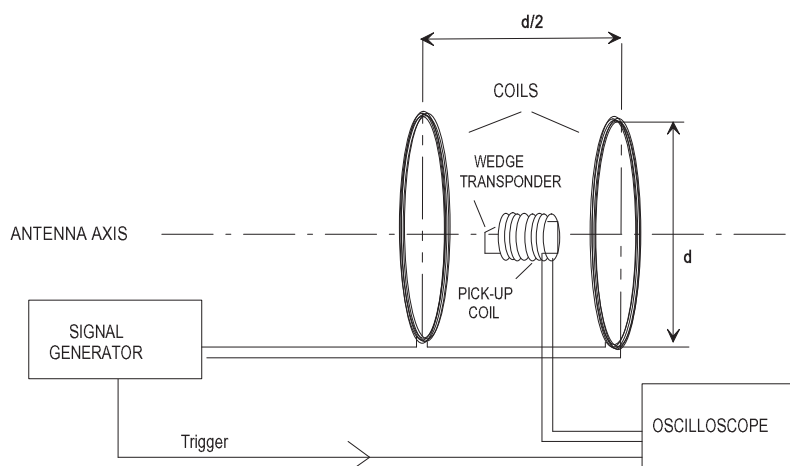

Figure 1-16. Test Setup for Powering Field Strength Determination

The field between both serial connected coils is homogeneous, due to the fact that the aperture is built according to the Helmholtz set-up. The circular coils are positioned in parallel on one axis. The distance between the coils is half the coil diameter. The transponder is positioned in the middle of the coil axis.

Determination of the minimum powering field strength is possible by changing the field strength through increasing the coil current. The relation between the generated magnetic flux/field strength and coil current can either be measured with a calibrated field probe, or calculated as follows:

$$B = \frac{4}{5} \cdot \sqrt{\frac{4}{5}} \cdot \frac{\mu_0 \cdot \mu_r \cdot N \cdot I}{d/2} = \mu_0 \cdot \mu_r \cdot H \quad (1-2)$$

B: magnetic flux (Tesla = Wb/m²)

H: magnetic field strength (A/m)

N: Number of Helmholtz Coil windings

d: Coil diameter (m)

I: Coil current (A)

μ_0 : magnetic field constant (Vs/Am) = $4 \times \pi \times 10^{-7}$ Vs/Am

μ_r : relative magnetic field constant (in air: = 1)

The Helmholtz set-up can be used for the specification of transponders in the temperature range from -40°C to $+85^\circ\text{C}$. Tests showed, however, that deviations of the field strength caused by temperature are negligible.

The data telegram of the transponder can be captured by a pick-up coil (for example: 10 windings, thin wire to minimize influence) which wraps the transponder. The pulse modulated signal can be adjusted at the signal generator. The measurement of the power pulse and transponder diagram can be done with the help of an oscilloscope triggered by the generator signal (see [Figure 1-16](#)). As soon as a data telegram is completely detected the minimum necessary field strength (calculated with [Equation 1-2](#)) can be monitored.

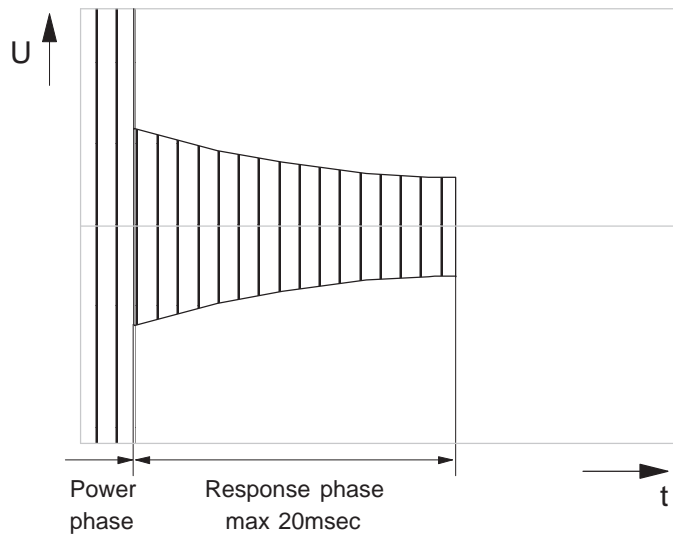

Figure 1-17. Received Signal at the Pickup Coil, if Power Field Strength Is Sufficient

1.6.3 Transponder Signal Strength

The wedge transponder has to be located into a homogeneous field (Helmholtz set-up). The pulsed power signal is generated by a signal generator. A calibrated field strength probe picks up the transponder signal. The field strength can be calculated by using the calibration factor of the field strength probe.

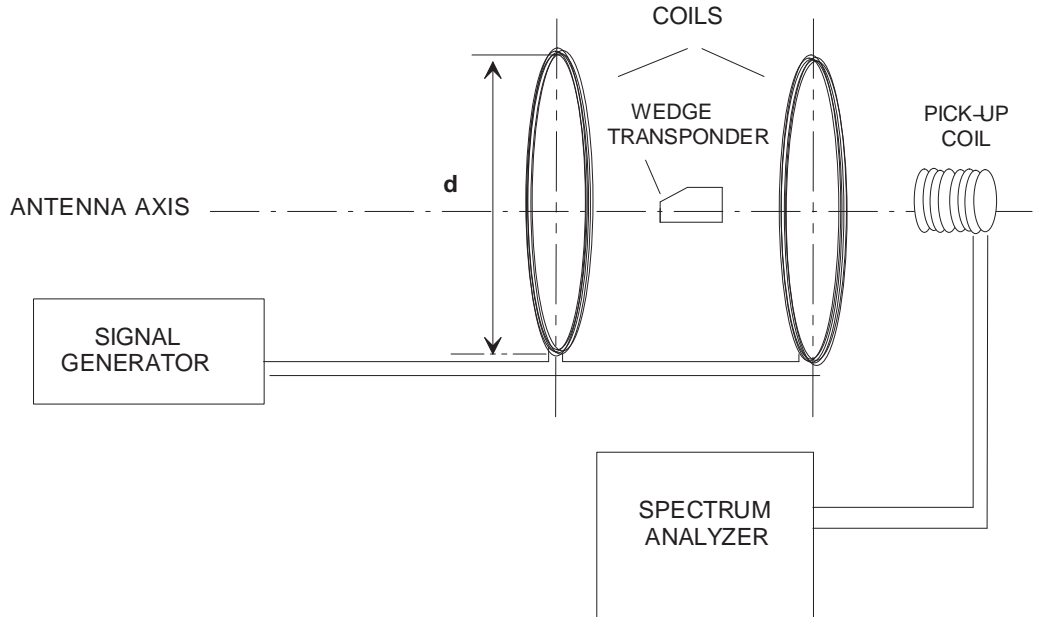

Figure 1-18. Determination of the Transponder Signal Strength (Data Transmission Signal Strength) With Helmholtz Aperture

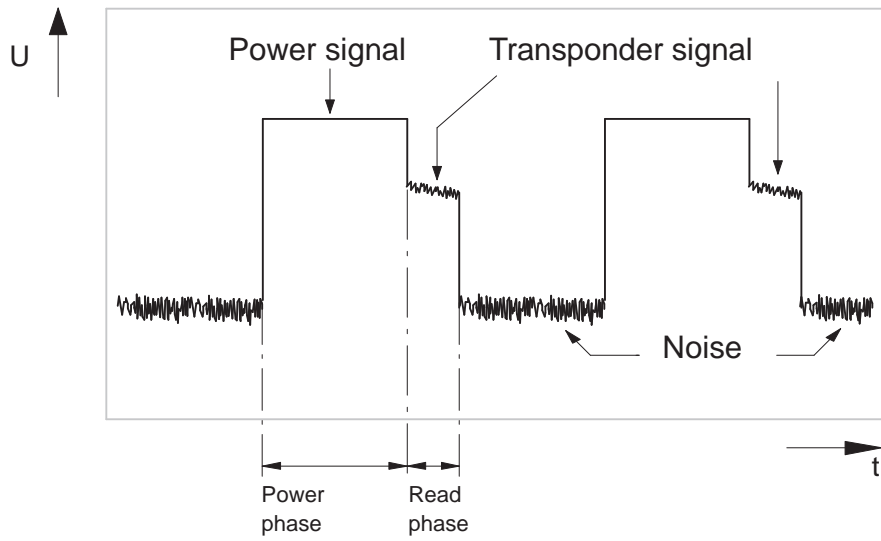

Figure 1-19. Monitored Signal Voltage at the Spectrum Analyzer (Time Domain Mode)

1.7 Absolute Maximum Ratings RI-TRP-W9WK

All data is given for free air operating temperature range (unless otherwise noted).

PARAMETER		CONDITION	MIN	NOM	MAX	UNIT
T _a read	Operating temperature (read)		-40		85	°C
T _a prog	Operating temperature (program)		-40		70	°C
T _s	Storage temperature		-40		100	°C
T _s	Storage temperature	5 min			175	°C
T _c	Temperature Cycle		-40		85	°C
H _{exc}	Field strength	134.2 kHz			168	dBμA/m

1.8 Absolute Maximum Ratings RI-TRP-R9BK

All data is given for free air operating temperature range (unless otherwise noted).

PARAMETER		CONDITION	MIN	NOM	MAX	UNIT
T _a read	Operating temperature (read)		-25		70	°C
T _s	Storage temperature		-40		100	°C
T _s	Storage temperature	5 min			175	°C
T _c	Temperature Cycle		-40		85	°C
H _{exc}	Field strength	134.2 kHz			168	dBμA/m

1.9 Recommended Operating Conditions

All data is given for free air operating temperature range (unless otherwise noted).

PARAMETER		CONDITION	MIN	NOM	MAX	UNIT
t _{exc}	Charge duration for read and write		15	50		ms
f _{exc}	Charge frequency for read and write		134.16	134.2	134.24	kHz
t _{prog}	Programming time		15			ms
H _{prog}	Programming field strength	t _{exc} = 50 ms		145		dBμA/m
H _{prog}	Programming field strength	+25°C t _{exc} = 50 ms		140		dBμA/m
H _{act}	Activation field strength	t _{exc} = 50 ms	137.5			dBμA/m
H _{act}	Activation field strength	+25°C t _{exc} = 50 ms	134.5			dBμA/m
t _{bit}	Write bit duration	(1)		2		ms
t _{offL}	Write pulse pause low bit	(1)		0.3		ms
t _{offH}	Write pulse pause high bit	(1)		1.0		ms

(1) Depending on reader characteristics and environmental conditions.

Characteristics

1.10 Characteristics

All data is given for free air temperature range (unless otherwise noted).

PARAMETER	CONDITION	MIN	NOM	MAX	UNIT	
Qop	Operating quality factor	(1)	62			
f _L	Low bit transmit frequency		130.2	139.5	kHz	
		+25°C	132.0	134.7		136.5
t _L	Low bit duration		0.115	0.119	0.123	ms
f _H	High bit transmit frequency		118.0	128.0	kHz	
		+25°C	120.0	123.7		126.5
t _H	High bit duration		0.125	0.129	0.136	ms
H _{out}	Transponder output field strength at 5 cm		76	99.5	dBμA/m	
m _{read}	FSK Modulation index (read); f _L – f _H	+25°C	11		kHz	
		(2)	9	15		
r _{read}	Data transmission rate (read)		7.4	8.7	kbit/s	
t _{read}	Data transmission time (read)		14.7	17.5	ms	
m _{write}	ASK modulation index (write)		100		%	
r _{write}	Data transmission rate (write)	(3)	0.5		kbit/s	
t _{write}	Data transmission time (write)	(3)	224		ms	

- (1) Specified Qop must be met in the application over the required temperature range. Refer to the test set-up shown in [Figure 1-14](#).
- (2) Maintained over specified temperature range.
- (3) Adaptable to application.

1.11 Environmental Data and Reliability

PARAMETER	CONDITION	MIN	NOM	MAX	UNIT
Programming cycles ⁽¹⁾	25°C	100 k			cycles
Data retention time ⁽¹⁾	100k cycles at 25°C storage temperature	10			years
EM radiation immunity	1... 512 MHz	100			V/m
	512 ... 1000 MHz	50			
ESD immunity	IEC 801-2	2			kV
X-ray dose				2000	RAD
Vibration ⁽²⁾	IEC 68-2-6, Test Fc				
Shock	IEC 68-2-27, Test Ea				

- (1) Cumulative failure rate 1%.
- (2) f = 10 – 2000 Hz

1.12 Memory

PARAMETER	DATA
Memory size	80 bits
Memory organization	1 block
Identification data	64 bit
Error detection (Data BCC)	CRC - CCITT, 16 bit

1.13 Package

PARAMETER	DATA
Dimensions	12 mm × 6 mm × 3 mm (see Figure 1-3)
Weight	0.4 g

1.14 Conversion Formula

Conversion formula between magnetic flux, magnetic field strength and electric field strength is given below:

$$B = \mu_0 \times H$$

$$E = Z_F \cdot H$$

$$H = \frac{E}{dB\mu V/m} - 51.5 \frac{dB\mu A}{m} ; [H] = \frac{dB\mu A}{m} ; [E] = \frac{dB\mu V}{m}$$

B = magnetic flux [Tesla = Wb/m² = Vs/m²]; 1 mWb/m² = 0.795 A/m

H = magnetic field strength [A/m or in logarithmic term dBμA/m]

E = electrical field strength [V/m or in logarithmic term dBμV/m]

μ₀ = magnetic field constant = 1.257 × 10⁻⁶ Vs/Am

Z_F = free space impedance = 120 πΩ = 377 Ω

IMPORTANT NOTICE

Texas Instruments Incorporated and its subsidiaries (TI) reserve the right to make corrections, modifications, enhancements, improvements, and other changes to its products and services at any time and to discontinue any product or service without notice. Customers should obtain the latest relevant information before placing orders and should verify that such information is current and complete. All products are sold subject to TI's terms and conditions of sale supplied at the time of order acknowledgment.

TI warrants performance of its hardware products to the specifications applicable at the time of sale in accordance with TI's standard warranty. Testing and other quality control techniques are used to the extent TI deems necessary to support this warranty. Except where mandated by government requirements, testing of all parameters of each product is not necessarily performed.

TI assumes no liability for applications assistance or customer product design. Customers are responsible for their products and applications using TI components. To minimize the risks associated with customer products and applications, customers should provide adequate design and operating safeguards.

TI does not warrant or represent that any license, either express or implied, is granted under any TI patent right, copyright, mask work right, or other TI intellectual property right relating to any combination, machine, or process in which TI products or services are used. Information published by TI regarding third-party products or services does not constitute a license from TI to use such products or services or a warranty or endorsement thereof. Use of such information may require a license from a third party under the patents or other intellectual property of the third party, or a license from TI under the patents or other intellectual property of TI.

Reproduction of information in TI data books or data sheets is permissible only if reproduction is without alteration and is accompanied by all associated warranties, conditions, limitations, and notices. Reproduction of this information with alteration is an unfair and deceptive business practice. TI is not responsible or liable for such altered documentation.

Resale of TI products or services with statements different from or beyond the parameters stated by TI for that product or service voids all express and any implied warranties for the associated TI product or service and is an unfair and deceptive business practice. TI is not responsible or liable for any such statements.

Following are URLs where you can obtain information on other Texas Instruments products and application solutions:

Products

Amplifiers	amplifier.ti.com
Data Converters	dataconverter.ti.com
DSP	dsp.ti.com
Interface	interface.ti.com
Logic	logic.ti.com
Power Mgmt	power.ti.com
Microcontrollers	microcontroller.ti.com
Low Power Wireless	www.ti.com/lpw

Applications

Audio	www.ti.com/audio
Automotive	www.ti.com/automotive
Broadband	www.ti.com/broadband
Digital Control	www.ti.com/digitalcontrol
Military	www.ti.com/military
Optical Networking	www.ti.com/opticalnetwork
Security	www.ti.com/security
Telephony	www.ti.com/telephony
Video & Imaging	www.ti.com/video
Wireless	www.ti.com/wireless

Mailing Address: Texas Instruments
Post Office Box 655303 Dallas, Texas 75265