

SN65LVDS4 Evaluation Module

The Texas Instruments SN65LVDS4 Evaluation Module board is used to evaluate the SN65LVDS4 LVDS receiver with selectable output levels.

Contents

1	Introduction	2
2	SN65LVDS4EVM Kit Contents	2
3	SN65LVDS4EVM Board Configuration	2
4	Power Supply Configuration	3
5	Test Setup	3
6	Schematic, Bill of Materials, and Board Layouts	4
6.1	Schematic	4
6.2	Bill of Materials	5
6.3	Board Layouts	6

List of Figures

1	SN65LVDS4EVM Board	2
2	SN65LVDS4 Schematic.....	4
3	SN65LVDS4EVM Board Layout, Top – Layer 1	6
4	SN65LVDS4EVM Board Layout, GND – Layer 2.....	7
5	SN65LVDS4EVM Board Layout, POWER – Layer 3	8
6	SN65LVDS4EVM Board Layout, Bottom – Layer 4	9

List of Tables

1	Power Supply Acceptable Combinations	3
2	EVM and Device Connections	3
3	SN65LVDS4EVM Bill of Materials	5
4	SN65LVDS4EVM Printed-Circuit Board Layer Construction	6

1 Introduction

The Texas Instruments SN65LVDS4 Evaluation Module (EVM) board is used to evaluate the SN65LVDS4 LVDS receiver. The device can provide output voltage logic levels based on an external VDD pin, thus eliminating the need for external level translation. The board enables the system designer to connect 50-Ω coaxial cables via SMA connectors at the inputs and an SMA or high-impedance probe at the output.

WARNING

This equipment is intended for use in a laboratory test environment only. It generates, uses, and can radiate radio frequency energy and has not been tested for compliance with the limits of computing devices pursuant to subpart J of part 15 of FCC rules, which are designed to provide reasonable protection against radio frequency interference. Operation of this equipment in other environments may cause interference with radio communications, in which case, users at their own expense will be required to take whatever measures may be required to correct this interference.

2 SN65LVDS4EVM Kit Contents

The SN65LVDS4EVM kit contains the following:

- SN65LVDS4EVM board
- SN65LVDS4EVM User's Guide (this document)

3 SN65LVDS4EVM Board Configuration

The SN65LVDS4 input differential pair (J1, J3) and single-ended output (J2) are available through the edge launch SMA connectors.

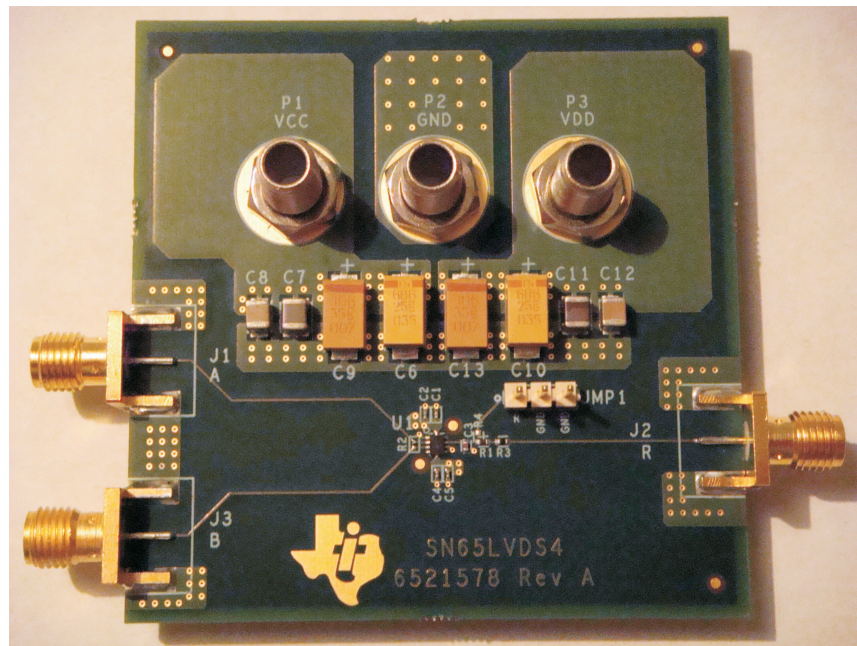

Figure 1. SN65LVDS4EVM Board

4 Power Supply Configuration

Two power supplies are needed to bias the SN65LVDS4 – VCC, the core power supply, and VDD, the output drive power supply. For proper device operation, it is recommended that VCC is powered up first and then VDD or VCC applied at the same time as VDD (In the later case, VCC and VDD are tied together). Further, it is also recommended that VCC is equal to or less than VDD as shown in [Table 1](#).

Table 1. Power Supply Acceptable Combinations

VCC (V)	VDD (V)	Recommended
1.8	1.8	Yes
1.8	2.5	Yes
1.8	3.3	Yes
2.5	1.8	No
2.5	2.5	Yes
2.5	3.3	Yes

5 Test Setup

Measuring the output signal on J2 with a 50-Ω cable terminated into 50 Ω at the scope attenuates the signal due to the 453-Ω resistor (R1) in series with the receiver output on the EVM board. The resistor is installed as a current limit for termination into a 50-Ω load, thus providing a 10x attenuation on the measured output signal.

Measuring the output signal with a high-impedance probe on JMP1 requires removing R1, the 453-Ω resistor, and installing a 0-Ω resistor on R4 (0402). Measuring the output signal on JMP1 allows the user to see absolute signal levels out of the device.

See [Table 2](#) for input and output connections.

Table 2. EVM and Device Connections

EVM Connection	Pin		I/O	Description
	Name	No.		
J1	A	2	I	LVDS input, positive
J3	B	3	I	LVDS input, negative
P2	GND	1, 7	—	Ground
—	NC	4, 6, 9	—	No connect
J2	R	8	O	1.8/2.5 LVCMOS/3.3 LVTTTL output
P1	VCC	5	—	Core supply voltage
P3	VDD	10	—	Output supply voltage

6 Schematic, Bill of Materials, and Board Layouts

6.1 Schematic

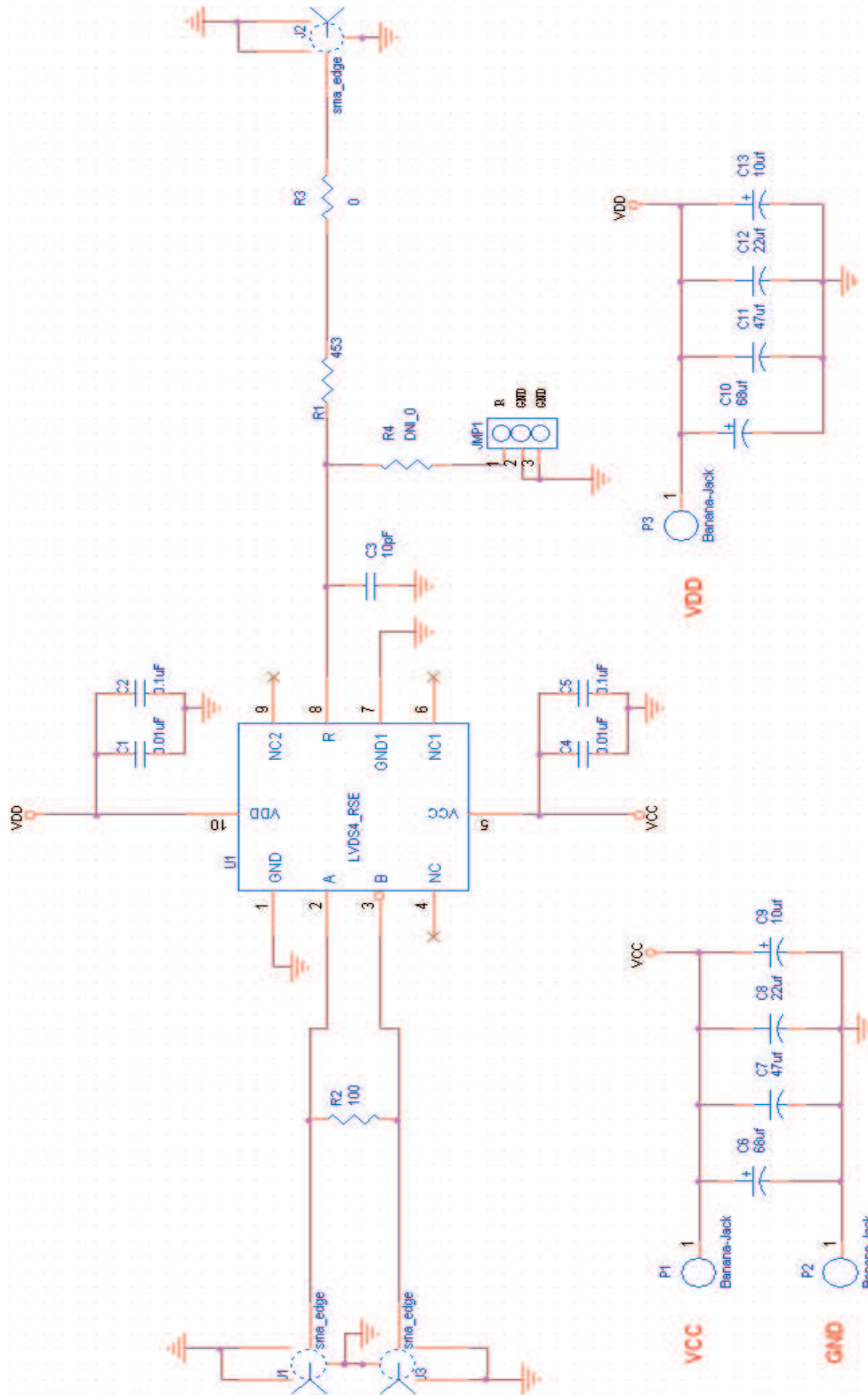

Figure 2. SN65LVDS4 Schematic

6.2 Bill of Materials

Table 3. SN65LVDS4EVM Bill of Materials

Qty	Reference	Value	Part	Part Number	Manufacturer
2	C1,C4	0.01 μ F	CC0201	GRM033R70J103KA01D	Murata
2	C2,C5	0.1 μ F	CC0201	GRM033R60J104KE19D	Murata
1	C3	10 pF	CC0402	ECD-G0E100C	Panasonic - ECG
2	C6,C10	68 μ F	CT7343	TAJE686K025R	AVX
2	C7,C11	47 μ F	CC1210	EMK325BJ476MM-T	Taiyo Yuden
2	C8,C12	22 μ F	CC1206	C1206X5R6R3-226KNE	Venkel
2	C9,C13	10 μ F	CT7343	C1206X7R160-106KNE	Venkel
1	JMP1	3 Pin Berg Jumper	HDR1X3	HTSW-150-07-G-S	Samtec
3	J1,J2,J3	sma_edge	JOHNSON_142-0701-801	142-0701-801	EF Johnson
3	P1,P2,P3	Banana-Jack	JOHNSON_108-0740-001	108-0740-001	Emerson Network Power
1	R1	453	R0402	RMCF0402FT453R	Stackpole Electronics
1	R2	100	R0201	ERJ-1GEJ101C	Panasonic - ECG
1	R3	0	R0402	RMCF0402ZT0R00	Stackpole Electronics
1	R4	DNI_0	R0402	RMCF0402ZT0R00	Stackpole Electronics
1	U1	SN65LVDS4	10-pin RSE	SN65LVDS4	Texas Instruments

6.3 Board Layouts

Table 4. SN65LVDS4EVM Printed-Circuit Board Layer Construction

Subclass Name	Type	Material	Thickness (mil)	Conductivity (mho/cm)	Dielectric Constant	Loss Tangent	Artwork	Width (mil)	Impedance (Ω) ⁽¹⁾
	SURFACE	AIR							
	MASK	LPI							
	FINISH	ENIG	1.29						
TOP	CONDUCTOR	COPPER	0.689	595900	1	0	POSITIVE	10	50
	DIELECTRIC	FR-4	6	0	4.2	0.035			
L2_GND	PLANE	COPPER	1.378	595900	1	0	POSITIVE		
	DIELECTRIC	FR-4	10	0	4.2	0.035			
L3_POWER	CONDUCTOR	COPPER	1.378	595900	1	0	POSITIVE		
	DIELECTRIC	FR-4	6	0	4.2	0.035			
BOTTOM	CONDUCTOR	COPPER	0.689	595900	1	0	POSITIVE	N/A	
	FINISH	ENIG	1.29						
	MASK	LPI							
	SURFACE	AIR							

⁽¹⁾ Always consult with your board manufacturer for their process/design requirements to ensure the desired impedance is achieved.

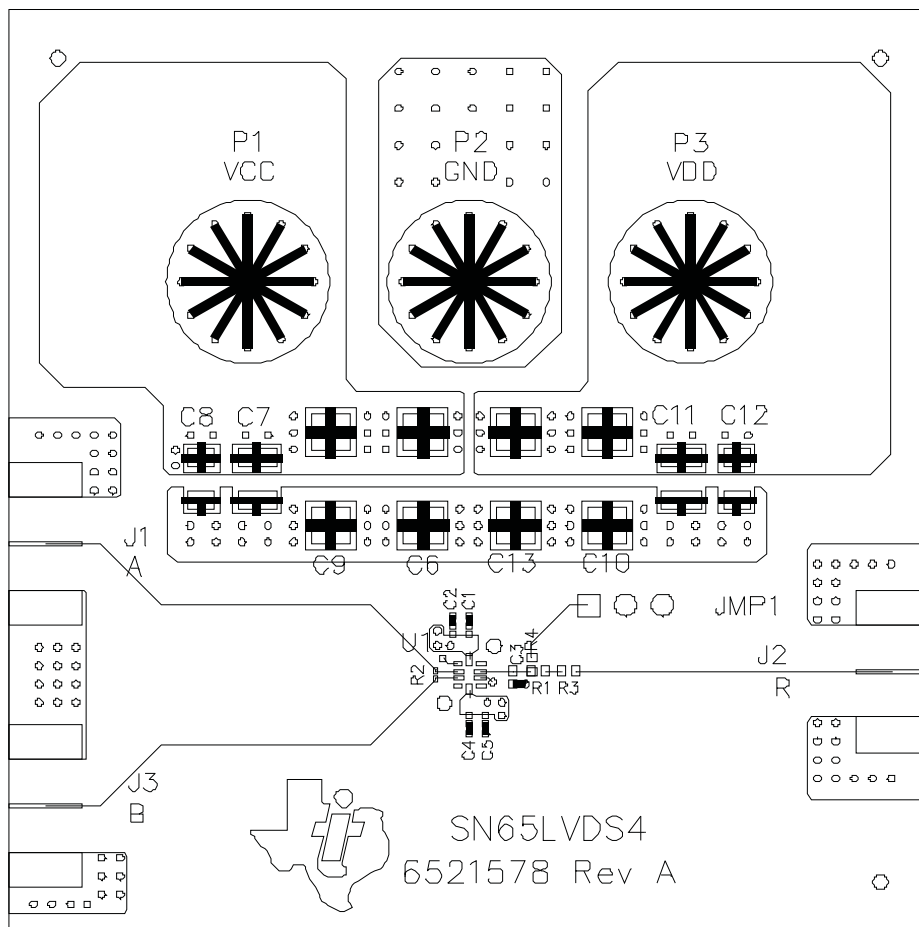

Figure 3. SN65LVDS4EVM Board Layout, Top – Layer 1

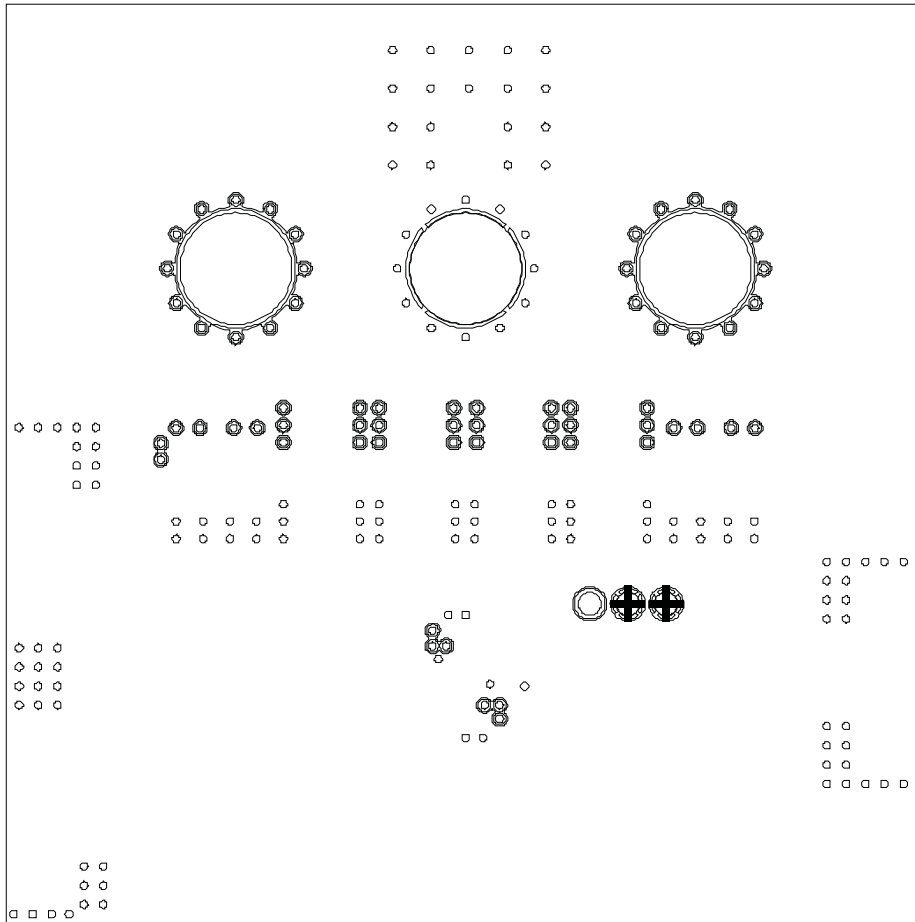

Figure 4. SN65LVDS4EVM Board Layout, GND – Layer 2

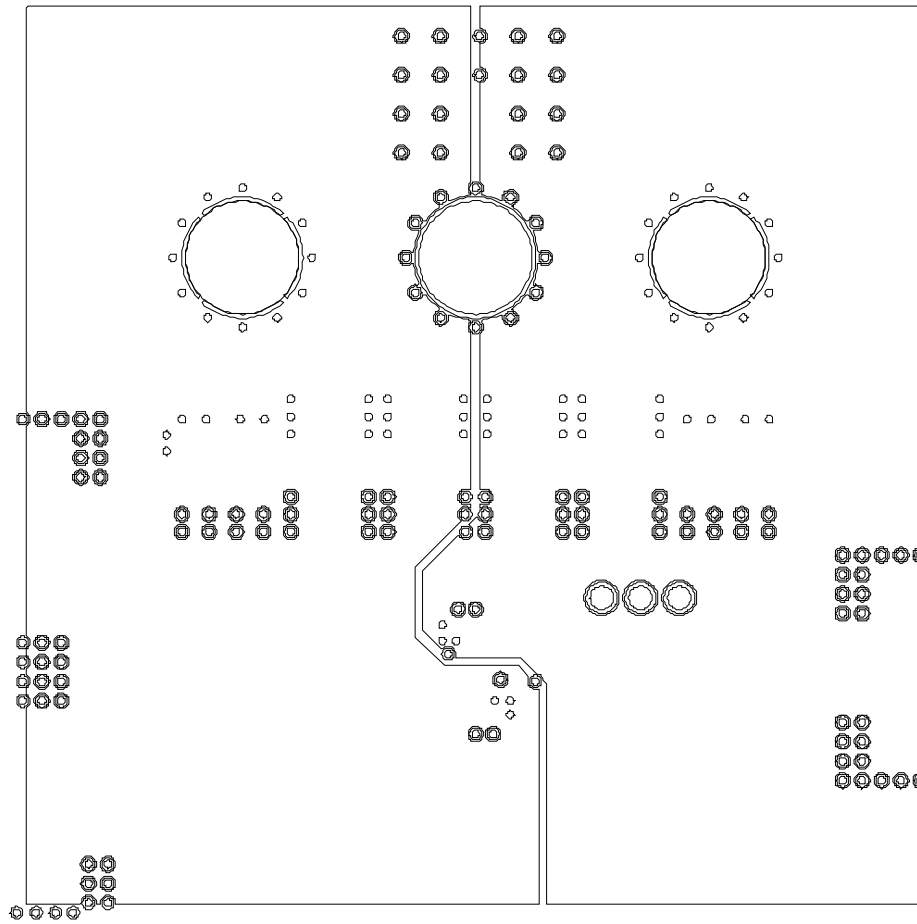

Figure 5. SN65LVDS4EVM Board Layout, POWER – Layer 3

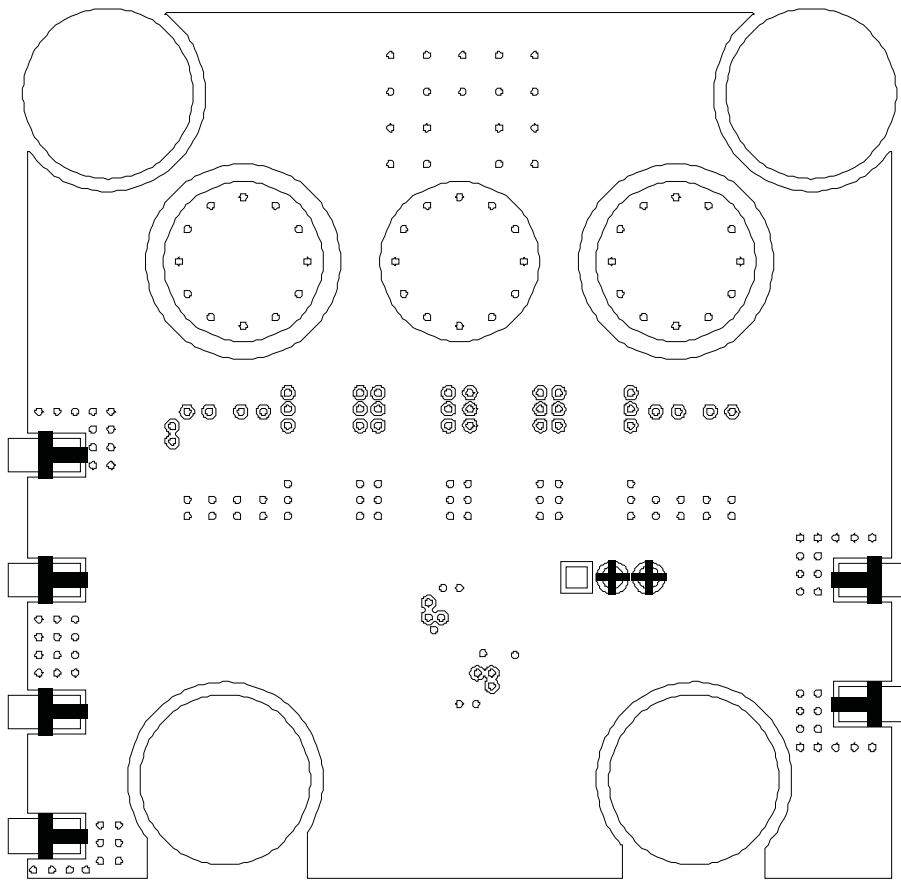

Figure 6. SN65LVDS4EVM Board Layout, Bottom – Layer 4

Evaluation Board/Kit Important Notice

Texas Instruments (TI) provides the enclosed product(s) under the following conditions:

This evaluation board/kit is intended for use for **ENGINEERING DEVELOPMENT, DEMONSTRATION, OR EVALUATION PURPOSES ONLY** and is not considered by TI to be a finished end-product fit for general consumer use. Persons handling the product(s) must have electronics training and observe good engineering practice standards. As such, the goods being provided are not intended to be complete in terms of required design-, marketing-, and/or manufacturing-related protective considerations, including product safety and environmental measures typically found in end products that incorporate such semiconductor components or circuit boards. This evaluation board/kit does not fall within the scope of the European Union directives regarding electromagnetic compatibility, restricted substances (RoHS), recycling (WEEE), FCC, CE or UL, and therefore may not meet the technical requirements of these directives or other related directives.

Should this evaluation board/kit not meet the specifications indicated in the User's Guide, the board/kit may be returned within 30 days from the date of delivery for a full refund. **THE FOREGOING WARRANTY IS THE EXCLUSIVE WARRANTY MADE BY SELLER TO BUYER AND IS IN LIEU OF ALL OTHER WARRANTIES, EXPRESSED, IMPLIED, OR STATUTORY, INCLUDING ANY WARRANTY OF MERCHANTABILITY OR FITNESS FOR ANY PARTICULAR PURPOSE.**

The user assumes all responsibility and liability for proper and safe handling of the goods. Further, the user indemnifies TI from all claims arising from the handling or use of the goods. Due to the open construction of the product, it is the user's responsibility to take any and all appropriate precautions with regard to electrostatic discharge.

EXCEPT TO THE EXTENT OF THE INDEMNITY SET FORTH ABOVE, NEITHER PARTY SHALL BE LIABLE TO THE OTHER FOR ANY INDIRECT, SPECIAL, INCIDENTAL, OR CONSEQUENTIAL DAMAGES.

TI currently deals with a variety of customers for products, and therefore our arrangement with the user **is not exclusive.**

TI assumes **no liability for applications assistance, customer product design, software performance, or infringement of patents or services described herein.**

Please read the User's Guide and, specifically, the Warnings and Restrictions notice in the User's Guide prior to handling the product. This notice contains important safety information about temperatures and voltages. For additional information on TI's environmental and/or safety programs, please contact the TI application engineer or visit www.ti.com/esh.

No license is granted under any patent right or other intellectual property right of TI covering or relating to any machine, process, or combination in which such TI products or services might be or are used.

FCC Warning

This evaluation board/kit is intended for use for **ENGINEERING DEVELOPMENT, DEMONSTRATION, OR EVALUATION PURPOSES ONLY** and is not considered by TI to be a finished end-product fit for general consumer use. It generates, uses, and can radiate radio frequency energy and has not been tested for compliance with the limits of computing devices pursuant to part 15 of FCC rules, which are designed to provide reasonable protection against radio frequency interference. Operation of this equipment in other environments may cause interference with radio communications, in which case the user at his own expense will be required to take whatever measures may be required to correct this interference.

EVM Warnings and Restrictions

It is important to operate this EVM within the input voltage range of 1.62 V to 2.75 V and the output voltage range of 1.62 V to 3.6 V.

Exceeding the specified input range may cause unexpected operation and/or irreversible damage to the EVM. If there are questions concerning the input range, please contact a TI field representative prior to connecting the input power.

Applying loads outside of the specified output range may result in unintended operation and/or possible permanent damage to the EVM. Please consult the EVM User's Guide prior to connecting any load to the EVM output. If there is uncertainty as to the load specification, please contact a TI field representative.

During normal operation, some circuit components may have case temperatures greater than 40° C. The EVM is designed to operate properly with certain components above 40° C as long as the input and output ranges are maintained. These components include but are not limited to linear regulators, switching transistors, pass transistors, and current sense resistors. These types of devices can be identified using the EVM schematic located in the EVM User's Guide. When placing measurement probes near these devices during operation, please be aware that these devices may be very warm to the touch.

Mailing Address: Texas Instruments, Post Office Box 655303, Dallas, Texas 75265
Copyright © 2011, Texas Instruments Incorporated

IMPORTANT NOTICE

Texas Instruments Incorporated and its subsidiaries (TI) reserve the right to make corrections, modifications, enhancements, improvements, and other changes to its products and services at any time and to discontinue any product or service without notice. Customers should obtain the latest relevant information before placing orders and should verify that such information is current and complete. All products are sold subject to TI's terms and conditions of sale supplied at the time of order acknowledgment.

TI warrants performance of its hardware products to the specifications applicable at the time of sale in accordance with TI's standard warranty. Testing and other quality control techniques are used to the extent TI deems necessary to support this warranty. Except where mandated by government requirements, testing of all parameters of each product is not necessarily performed.

TI assumes no liability for applications assistance or customer product design. Customers are responsible for their products and applications using TI components. To minimize the risks associated with customer products and applications, customers should provide adequate design and operating safeguards.

TI does not warrant or represent that any license, either express or implied, is granted under any TI patent right, copyright, mask work right, or other TI intellectual property right relating to any combination, machine, or process in which TI products or services are used. Information published by TI regarding third-party products or services does not constitute a license from TI to use such products or services or a warranty or endorsement thereof. Use of such information may require a license from a third party under the patents or other intellectual property of the third party, or a license from TI under the patents or other intellectual property of TI.

Reproduction of TI information in TI data books or data sheets is permissible only if reproduction is without alteration and is accompanied by all associated warranties, conditions, limitations, and notices. Reproduction of this information with alteration is an unfair and deceptive business practice. TI is not responsible or liable for such altered documentation. Information of third parties may be subject to additional restrictions.

Resale of TI products or services with statements different from or beyond the parameters stated by TI for that product or service voids all express and any implied warranties for the associated TI product or service and is an unfair and deceptive business practice. TI is not responsible or liable for any such statements.

TI products are not authorized for use in safety-critical applications (such as life support) where a failure of the TI product would reasonably be expected to cause severe personal injury or death, unless officers of the parties have executed an agreement specifically governing such use. Buyers represent that they have all necessary expertise in the safety and regulatory ramifications of their applications, and acknowledge and agree that they are solely responsible for all legal, regulatory and safety-related requirements concerning their products and any use of TI products in such safety-critical applications, notwithstanding any applications-related information or support that may be provided by TI. Further, Buyers must fully indemnify TI and its representatives against any damages arising out of the use of TI products in such safety-critical applications.

TI products are neither designed nor intended for use in military/aerospace applications or environments unless the TI products are specifically designated by TI as military-grade or "enhanced plastic." Only products designated by TI as military-grade meet military specifications. Buyers acknowledge and agree that any such use of TI products which TI has not designated as military-grade is solely at the Buyer's risk, and that they are solely responsible for compliance with all legal and regulatory requirements in connection with such use.

TI products are neither designed nor intended for use in automotive applications or environments unless the specific TI products are designated by TI as compliant with ISO/TS 16949 requirements. Buyers acknowledge and agree that, if they use any non-designated products in automotive applications, TI will not be responsible for any failure to meet such requirements.

Following are URLs where you can obtain information on other Texas Instruments products and application solutions:

Products

Audio	www.ti.com/audio
Amplifiers	amplifier.ti.com
Data Converters	dataconverter.ti.com
DLP® Products	www.dlp.com
DSP	dsp.ti.com
Clocks and Timers	www.ti.com/clocks
Interface	interface.ti.com
Logic	logic.ti.com
Power Mgmt	power.ti.com
Microcontrollers	microcontroller.ti.com
RFID	www.ti-rfid.com
RF/IF and ZigBee® Solutions	www.ti.com/lprf

Applications

Communications and Telecom	www.ti.com/communications
Computers and Peripherals	www.ti.com/computers
Consumer Electronics	www.ti.com/consumer-apps
Energy and Lighting	www.ti.com/energy
Industrial	www.ti.com/industrial
Medical	www.ti.com/medical
Security	www.ti.com/security
Space, Avionics and Defense	www.ti.com/space-avionics-defense
Transportation and Automotive	www.ti.com/automotive
Video and Imaging	www.ti.com/video
Wireless	www.ti.com/wireless-apps

TI E2E Community Home Page

e2e.ti.com

Mailing Address: Texas Instruments, Post Office Box 655303, Dallas, Texas 75265
Copyright © 2011, Texas Instruments Incorporated