

DRV84xx Evaluation Module User's Guide

This document is provided with the DRV84xx evaluation module (EVM) as a supplement to the DRV84xx Stepper Motor Driver datasheet. This user's guide details the hardware implementation of the EVM. Details on using the graphical user interface (GUI) software with this EVM can be found in the [DRV84xxEVM GUI User's Guide](#), [DRV84xxPEVM GUI User's Guide](#) and [DRV84xxEEVM GUI User's Guide](#).

Contents

1	Board Overview	2
2	Introduction	2
	2.1 Connectors	2
	2.2 Test Points	3
	2.3 Jumpers	4
	2.4 Motor Outputs	4
	2.5 EVM Operation	4
	2.6 EVM documentation	4

List of Figures

1	Top view of typical board configuration (EVM provided may vary)	2
2	Connections	3

List of Tables

1	Connections to DRV84xx Using External Microcontroller	3
---	---	---

Trademarks

MSP430 is a trademark of Texas Instruments.
 Windows is a registered trademark of Microsoft Corporation.
 All other trademarks are the property of their respective owners.

1 Board Overview



WARNING

DRV84xxEVM is rated for power supply voltages between 4.5 VDC and 48 VDC max. The components can support peak output currents up to a maximum 4A. To minimize risk or personal injury, fire and/or property damage, always maintain component temperatures below the 130°C rating of the printed circuit board material.

Figure 1 shows the top view of the printed circuit board (PCB).



Figure 1. Top view of typical board configuration (EVM provided may vary)

2 Introduction

The DRV84xx EVM is a platform to support prototyping and evaluation for the DRV84xx devices, a medium-voltage dual H-bridge driver for stepper driving applications. The DRV84xx drives a single bipolar stepper with microstepping resolutions down to 1/256. It provides a variety of programmable decay settings.

The EVM uses an MSP430™ microcontroller and a USB interface chip to manage communication from the GUI software application installed on a PC computer with Windows®. The GUI sends serial commands to the MSP430 to control the device signals, monitor faults, read and write SPI registers, and drive a motor.

This user's guide details the hardware configurability of the evaluation module.

2.1 Connectors

The DRV84xx EVM supplies the VM (motor voltage) power rail through a reverse-battery protection circuit through the terminal block (J1). A set of test clips in parallel with the terminal block provide connections to monitor the input power rail.

The user must apply the VM voltage according to the recommended parameters listed in the datasheet (4.5 V to 48 V).

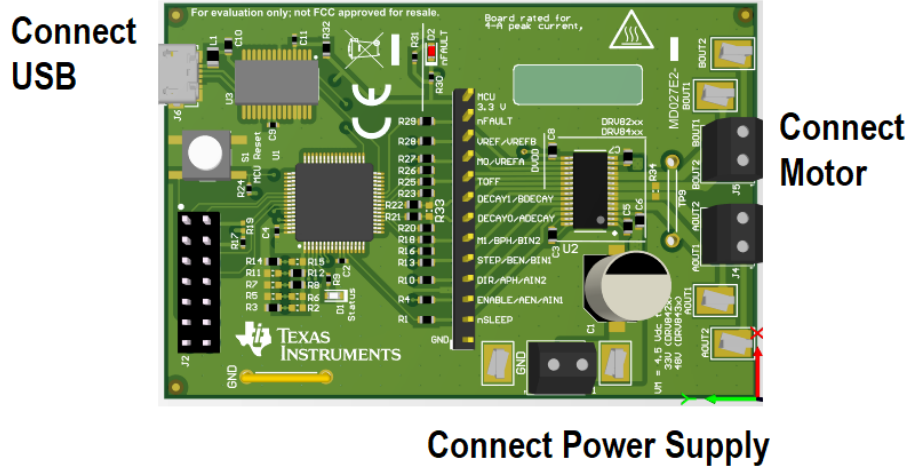

Figure 2. Connections

2.2 Test Points

A header connector with 0.100-inch pitch (J3) provides access to the DRV84xx signals. This can be used for measurement or as a connector to control the DRV84xx from an external microcontroller for prototype purposes. To disconnect the on-board MSP430 microcontroller, remove related zero ohm resistors between the MSP430 and the J3 header. Table 1 describes the connections available on the J3 header. Each header pin is labeled on the evaluation module and connects to a similarly named pin of the DRV84xx.

Table 1. Connections to DRV84xx Using External Microcontroller

Header Label	Description
MCU 3.3 V	3.3 V rail for the on-board MSP430 and nFAULT LED
nFAULT	Fault output.
VREF/VREFB	Current set reference input (DRV84xx) or Bridge B.current set reference input (DRV84xxE/P).
MO/VREFA	Microstepping mode-setting pin (DRV84xx) or Bridge A.current set reference input (DRV84xxE/P).
TOFF	Sets the Decay mode off time during current chopping.
DECAY0/BDECAY	Decay-mode setting pins.
DECAY1/ADECAY	Decay-mode setting pins.
M1/BPH/BIN2	Microstepping mode-setting pin (DRV84xx); or Bridge B phase input (DRV84xxE) or PWM input (DRV84xxP).
STEP/BEN/BIN1	STEP pin (DRV84xx); or Bridge B enable input (DRV84xxE) or PWM input (DRV84xxP).
DIR/APH/AIN2	DIR pin (DRV84xx); or Bridge A phase input (DRV84xxE) or PWM input (DRV84xxP).
ENABLE/AEN/AIN1	Enable pin (DRV84xx); or Bridge A enable input (DRV84xxE) or Bridge A PWM input (DRV84xxP).
nSLEEP	Sleep mode input.

Table 1. Connections to DRV84xx Using External Microcontroller (continued)

Header Label	Description
GND	Ground

2.3 Jumpers

The DRV84xx EVM has no jumpers.

2.4 Motor Outputs

Two motor connectors are provided (J6 and J7).

2.5 EVM Operation

Use the following steps to operate the EVM:

- Step 1. Install the drivers and GUI. For instructions see [DRV84xxEVM GUI User's Guide](#), [DRV84xxPEVM GUI User's Guide](#) or [DRV84xxEEVM GUI User's Guide](#).
- Step 2. Connect the wires of the stepper motor to the AOUT1, AOUT2, BOUT1, and BOUT2 terminals.
- Step 3. Connect the VM power supply to VM or VBAT connections, but do not apply power at this step.
- Step 4. Connect the USB cable between the PC and the EVM. When the USB is connected to the EVM, the status LED will begin to blink.
- Step 5. Open the GUI. The GUI can be found in the start menu at Texas Instruments → DRV84xx X.Y.Z, where X, Y, and Z are the revision numbers (to be verified) or by typing "DRV84xx" into the search bar of the start menu. If a shortcut was created, double-click on the shortcut to open the GUI. The GUI can take up to 30 seconds to establish a connection. If connection is not established, select the COM port under the *Options* menu. The baud rate is 9600.
- Step 6. Apply the desired voltage (4.5 to 40 V) to the VM/VBAT and GND connections.
- Step 7. For more instructions on how to control the DRV84xx EVM from the GUI, see [DRV84xxEVM GUI User's Guide](#), [DRV84xxPEVM GUI User's Guide](#) or [DRV84xxEEVM GUI User's Guide](#).

2.6 EVM documentation

The EVM schematics, layout, and BOM are provided in the [DRV84xxEVM hardware files](#). The GUI, USB drivers, and MSP430F2617 source code are provided in the DRV84xxEVM firmware and GUI software files.

IMPORTANT NOTICE AND DISCLAIMER

TI PROVIDES TECHNICAL AND RELIABILITY DATA (INCLUDING DATASHEETS), DESIGN RESOURCES (INCLUDING REFERENCE DESIGNS), APPLICATION OR OTHER DESIGN ADVICE, WEB TOOLS, SAFETY INFORMATION, AND OTHER RESOURCES "AS IS" AND WITH ALL FAULTS, AND DISCLAIMS ALL WARRANTIES, EXPRESS AND IMPLIED, INCLUDING WITHOUT LIMITATION ANY IMPLIED WARRANTIES OF MERCHANTABILITY, FITNESS FOR A PARTICULAR PURPOSE OR NON-INFRINGEMENT OF THIRD PARTY INTELLECTUAL PROPERTY RIGHTS.

These resources are intended for skilled developers designing with TI products. You are solely responsible for (1) selecting the appropriate TI products for your application, (2) designing, validating and testing your application, and (3) ensuring your application meets applicable standards, and any other safety, security, or other requirements. These resources are subject to change without notice. TI grants you permission to use these resources only for development of an application that uses the TI products described in the resource. Other reproduction and display of these resources is prohibited. No license is granted to any other TI intellectual property right or to any third party intellectual property right. TI disclaims responsibility for, and you will fully indemnify TI and its representatives against, any claims, damages, costs, losses, and liabilities arising out of your use of these resources.

TI's products are provided subject to TI's Terms of Sale (www.ti.com/legal/termsofsale.html) or other applicable terms available either on ti.com or provided in conjunction with such TI products. TI's provision of these resources does not expand or otherwise alter TI's applicable warranties or warranty disclaimers for TI products.

Mailing Address: Texas Instruments, Post Office Box 655303, Dallas, Texas 75265
Copyright © 2020, Texas Instruments Incorporated