

# TPS548D22 SWIFT™ Step-Down Converter Evaluation Module User's Guide



## Table of Contents

<b>1 Introduction</b> .....	3
<b>2 Description</b> .....	3
2.1 Typical End-User Applications.....	3
2.2 EVM Features.....	3
<b>3 EVM Electrical Performance Specifications</b> .....	4
<b>4 Schematic</b> .....	5
<b>5 Test Equipment</b> .....	6
<b>6 The PWR-784EVM</b> .....	7
<b>7 List of Test Points, Jumpers, and Switch</b> .....	8
<b>8 Test Procedure</b> .....	9
8.1 Line and Load Regulation Measurement Procedure.....	9
8.2 Efficiency.....	9
8.3 Equipment Shutdown.....	9
<b>9 Performance Data and Typical Characteristic Curves</b> .....	10
9.1 Efficiency.....	10
9.2 Load Regulation.....	10
9.3 Line Regulation.....	11
9.4 Transient Response.....	11
9.5 Output Ripple.....	12
9.6 Control On.....	13
9.7 Control Off.....	14
9.8 Thermal Image.....	14
<b>10 EVM Assembly Drawing and PCB Layout</b> .....	15
<b>11 List of Materials</b> .....	20
<b>12 Revision History</b> .....	21

## List of Figures

Figure 4-1. PWR-784EVM Schematic.....	5
Figure 6-1. PWR-784EVM Overview.....	7
Figure 6-2. Tip and Barrel Measurement.....	7
Figure 9-1. Efficiency of 1-V Output vs Load.....	10
Figure 9-2. Load Regulation of 1-V Output.....	10
Figure 9-3. Line Regulation of 1-V Output.....	11
Figure 9-4. Transient Response of 1-V Output at 12 V <sub>IN</sub> , Transient is 8 A to 32 A, 2.5 A/μs.....	11
Figure 9-5. Output Ripple and SW Node of 1-V Output at 12 V <sub>IN</sub> , 0-A Output.....	12
Figure 9-6. Output Ripple and SW Node of 1-V Output at 12 V <sub>IN</sub> , 40-A Output.....	12
Figure 9-7. Start up from Control, 1-V Output at 12 V <sub>IN</sub> , 40-A Output.....	13
Figure 9-8. 0.5-V Pre-bias start up from Control, 1-V Output at 12 V <sub>IN</sub> , 40-A Output.....	13
Figure 9-9. Soft Stop from Control, 1-V Output at 12 V <sub>IN</sub> , 40-A Output.....	14
Figure 9-10. Thermal Image at 1-V Output at 12 V <sub>IN</sub> , 40-A Output.....	14
Figure 10-1. PWR-681EVM Top Layer Assembly Drawing (top view).....	15
Figure 10-2. PWR-784EVM Top Solder Mask (top view).....	15
Figure 10-3. PWR-784EVM Top Layer (top view).....	16
Figure 10-4. PWR-784EVM Inner Layer 1 (top view).....	16
Figure 10-5. PWR-784EVM Inner Layer 2 (top view).....	17
Figure 10-6. PWR-784EVM Inner Layer 3 (top view).....	17
Figure 10-7. PWR-784EVM Inner Layer 4 (top view).....	18
Figure 10-8. PWR-784EVM Bottom Layer (top view).....	18
Figure 10-9. PWR-784EVM Bottom Solder Mask (top view).....	19

Figure 10-10. PWR-784EVM Bottom Overlay Layer (top view).....	19
---	----

### List of Tables

Table 3-1. PWR-784EVM Electrical Performance Specifications.....	4
Table 7-1. The Function of Each Test Point.....	8
Table 8-1. List of Test Points for Line and Load Measurements.....	9
Table 8-2. List of Test Points for Efficiency Measurements.....	9
Table 11-1. PWR784 List of Materials.....	20

### Trademarks

All trademarks are the property of their respective owners.

## 1 Introduction

The PWR784EVM evaluation module uses the TPS548D22 device. The TPS548D22 is a highly integrated synchronous buck converter that is designed for up to 40-A current output.

## 2 Description

The PWR784EVM is designed as a single output DC-DC converter that demonstrates the TPS548D22 in a typical low-voltage application while providing a number of test points to evaluate the performance. It uses a nominal 12-V input bus to produce a regulated 1-V output at up to 40-A load current.

### 2.1 Typical End-User Applications

- Enterprise Storage, SSD, NAS
- Wireless and Wired Communication Infrastructure
- Industrial PCs, Automation, ATE, PLC, Video Surveillance
- Enterprise Server, Switches, Routers
- AISIC, SoC, FPGA, DSP Core and I/O Rails

### 2.2 EVM Features

- Regulated 1-V output up to 40-A, steady-state output current
- Convenient Test Points for Probing Critical Waveforms

### 3 EVM Electrical Performance Specifications

**Table 3-1. PWR-784EVM Electrical Performance Specifications**

PARAMETER	TEST CONDITIONS	MIN	TYP	MAX	UNITS
<b>Input Characteristics</b>					
Voltage range	$V_{IN}$ tied to VDD	5	12	16	V
Maximum input current	$V_{IN} = 12\text{ V}$ , $I_O = 40\text{ A}$			12	A
No load input current	$V_{IN} = 12\text{ V}$ , $I_O = 0\text{ A}$		60		mA
<b>Output Characteristics</b>					
$V_{OUT}$ Output voltage	Output current = 10 A		1		V
$I_{OUT}$ Output load current	$I_{OUT(min)}$ to $I_{OUT(max)}$	0		40	A
Output voltage regulation	Line regulation: input voltage = 5 V to 16 V		0.5%		
	Load regulation: output current = 0 A to $I_{OUT(max)}$		0.5%		
$V_{OUT}$ Output voltage ripple	$V_{IN} = 12\text{ V}$ , $I_{OUT} = 40\text{ A}$		10		mV <sub>PP</sub>
$V_{OUT}$ Output overcurrent			46		A
<b>Systems Characteristics</b>					
Switching frequency	$F_{SW}$		650		kHz
$V_{OUT}$ Peak efficiency	$V_{IN} = 12\text{ V}$ , $I_O = 18\text{ A}$ , $F_{SW} = 650\text{ kHz}$		89%		
Operating temperature	$T_{oper}$	0		105	°C

## 4 Schematic

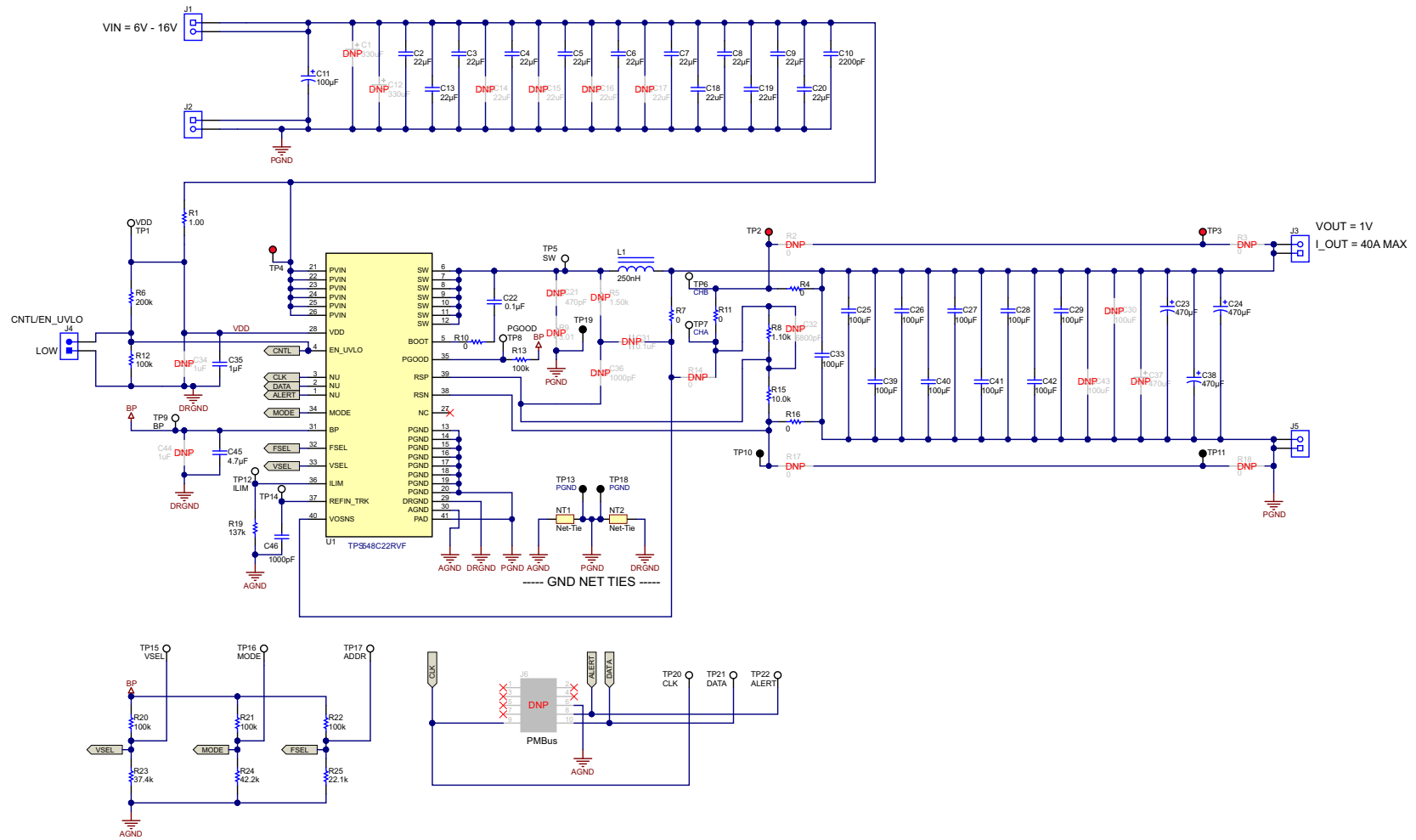

Figure 4-1. PWR-784EVM Schematic

## 5 Test Equipment

**Voltage Source:** The input voltage source  $V_{IN}$  must be a 0-V to 18-V variable DC source capable of supplying at least 12 A<sub>DC</sub>.

**Multimeters:** It is recommended to use two separate multimeters [Figure 6-1](#). One meter is used to measure  $V_{IN}$  and one to measure  $V_{OUT}$ .

**Output Load:** A variable electronic load is recommended for testing [Figure 6-1](#). It must be capable of 40 A at voltages as low as 0.6 V.

**Oscilloscope:** An oscilloscope is recommended for measuring output noise and ripple. Output ripple must be measured using a tip-and-barrel method or better as shown in [Figure 6-2](#). The scope must be adjusted to 20-MHz bandwidth, AC coupling at 50 mV/division, and must be set to 1- $\mu$ s/division.

**Fan:** During prolonged operation at high loads, it may be necessary to provide forced air cooling with a small fan aimed at the EVM. Temperature of the devices on the EVM must be maintained below 105°C.

**Recommended Wire Gauge:** The voltage drop in the load wires must be kept as low as possible in order to keep the working voltage at the load within its operating range. Use the AWG 14 wire (2 wires parallel for  $V_{OUT}$  positive and 2 wires parallel for the  $V_{OUT}$  negative) of no more than 1.98 feet between the EVM and the load. This recommended wire gauge and length should achieve a voltage drop of no more than 0.2 V at the maximum 40-A load.

## 6 The PWR-784EVM

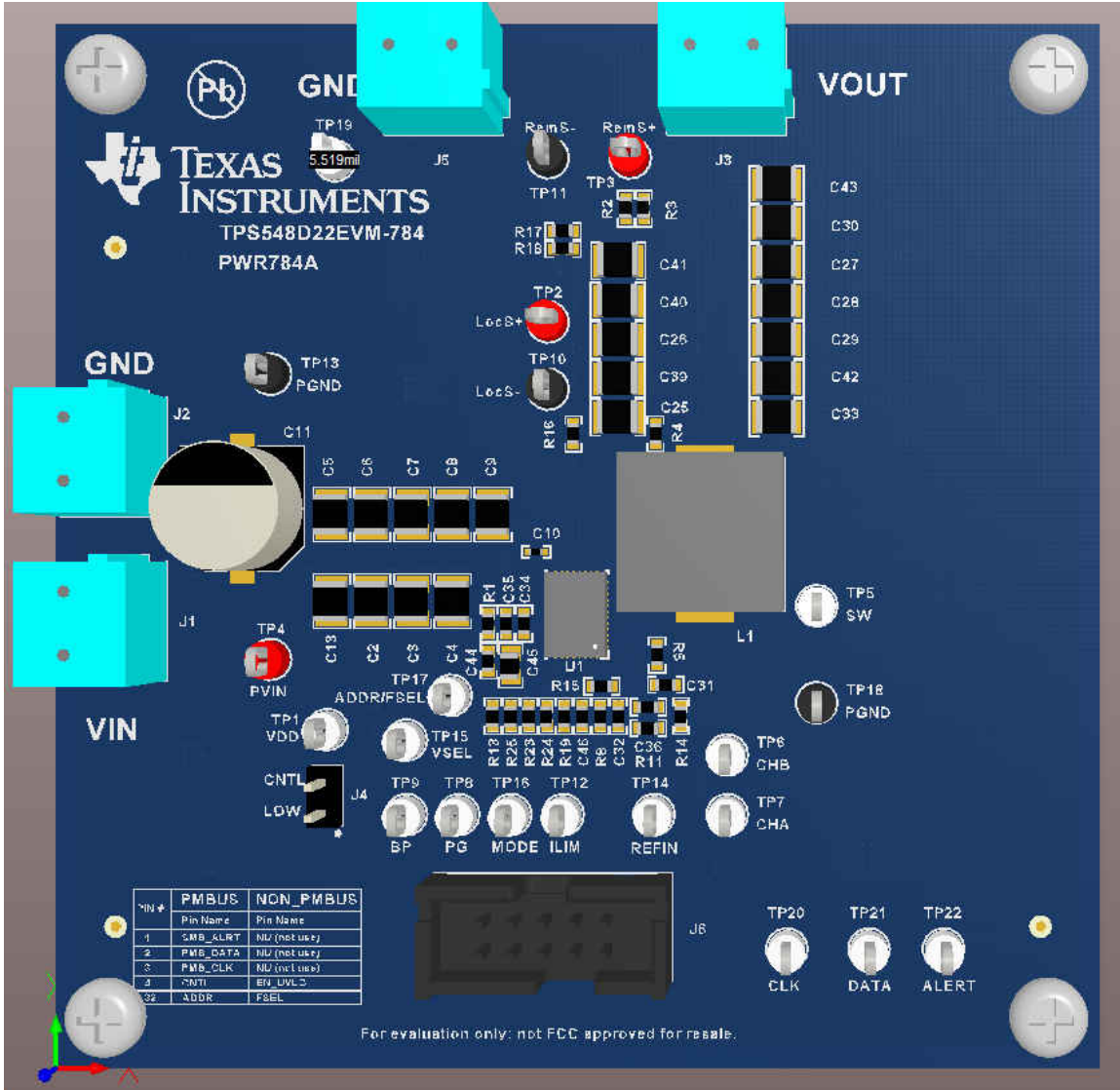
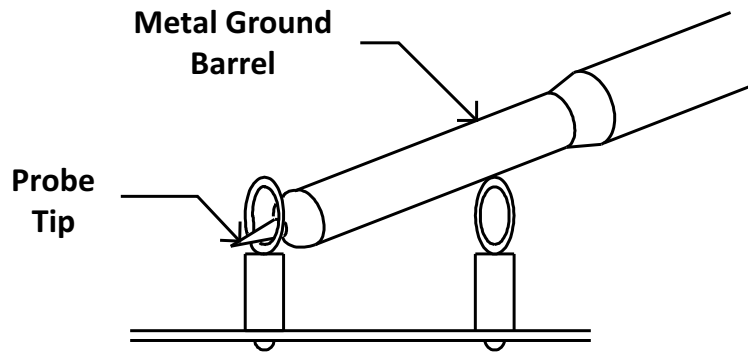

Figure 6-1. PWR-784EVM Overview



### Tip and Barrel $V_{OUT}$ Ripple Measurement

Figure 6-2. Tip and Barrel Measurement

## 7 List of Test Points, Jumpers, and Switch

**Table 7-1. The Function of Each Test Point**

ITEM	TYPE	NAME	DESCRIPTION
TP5	T-H loop	SW	Power supply Switch node
TP7	T-H loop	CH-A	Measure loop stability
TP6	T-H loop	CH-B	Measure loop stability
TP2	T-H loop	LocS+	Sense VOUT + locally across C5. Use for efficiency and ripple measurements
TP10	T-H loop	LocS-	Sense VOUT – locally across C5. Use for efficiency and ripple measurements
TP3	T-H loop	RemS+	Remote sense +
TP11	T-H loop	RemS-	Remote sense –
TP4	T-H loop	PVIN	Sense VIN + across C10
TP13	T-H loop	PGND	Sense VIN – across C10
TP1	T-H loop	VDD	Supplies the internal circuitry
TP17	T-H loop	FSEL	Monitor the FSEL external resistor divider ratio during initial power up.
TP15	T-H loop	VSEL	Monitor the VSEL external resistor divider ratio during initial power up.
TP9	T-H loop	BP	LDO output
TP8	T-H loop	PG	Power good
TP16	T-H loop	MODE	Monitor the MODE external resistor divider ratio during initial power up.
TP12	T-H loop	ILIM	Program over-current limit.
TP14	T-H loop	REFIN_TRK	Do not connect. <sup>(1)</sup>
TP19	T-H loop	PGND	Common GND
TP18	T-H loop	PGND	Common GND
TP20	T-H loop	CLK	Not used
TP21	T-H loop	DATA	Not used
TP22	T-H loop	ALERT	Not used
JP4	2-pin jumper	CNTL	Shunts control pin to GND

(1) Pin name changes to RESV\_TRK.



## 8 Test Procedure

### 8.1 Line and Load Regulation Measurement Procedure

1. Connect VOUT to J3 and VOUT\_GND to J5 [Figure 6-1](#).
2. Ensure that the electronic load is set to draw 0 A<sub>DC</sub>.
3. Connect VIN to J1 and VIN\_GND to J2 [Figure 6-1](#).
4. Increase V<sub>IN</sub> from 0 V to 12 V using the digital multimeter to measure input voltage.
5. Use the other digital multimeter to measure output voltage V<sub>OUT</sub> at TP2 and TP10.

**Table 8-1. List of Test Points for Line and Load Measurements**

TEST POINT	NODE NAME	DESCRIPTION
TP2	LocS+	Sense VOUT + locally across C5. Use for efficiency and ripple measurements
TP10	LocS-	Sense VOUT - locally across C5. Use for efficiency and ripple measurements
TP4	PVIN	Sense VIN + across C10
TP13	PGND	Sense VIN - across C10

6. Vary the load from 0 A<sub>DC</sub> to maximum rated output 40 A<sub>DC</sub>. V<sub>OUT</sub> must remain in regulation as defined in [Table 3-1](#).
7. Vary V<sub>IN</sub> from 5 V to 16 V. V<sub>OUT</sub> must remain in regulation as defined in [Table 3-1](#).
8. Decrease the load to 0 A.
9. Decrease V<sub>IN</sub> to 0 V or turn off the supply.

### 8.2 Efficiency

To measure the efficiency of the power train on the EVM, it is important to measure the voltages at the correct location. This is necessary because otherwise the measurements will include losses in efficiency that are not related to the power train itself. Losses incurred by the voltage drop in the copper traces and in the input and output connectors are not related to the efficiency of the power train, and they must not be included in efficiency measurements.

**Table 8-2. List of Test Points for Efficiency Measurements**

TEST POINT	NODE NAME	DESCRIPTION
TP2	LocS+	Sense VOUT + locally across C5. Use for efficiency and ripple measurements
TP10	LocS-	Sense VOUT - locally across C5. Use for efficiency and ripple measurements
TP4	PVIN	Sense VIN + across C10
TP13	PGND	Sense VIN - across C10

Input current can be measured at any point in the input wires, and output current can be measured anywhere in the output wires of the output being measured. Using these measurement points result in efficiency measurements that do not include losses due to the connectors and PCB traces.

### 8.3 Equipment Shutdown

1. Reduce the load current to 0 A.
2. Reduce input voltage to 0 V.
3. Shut down the external fan if in use.
4. Shut down equipment.

## 9 Performance Data and Typical Characteristic Curves

Figure 9-1 through Figure 9-10 present typical performance curves for the PWR-784EVM.

### 9.1 Efficiency

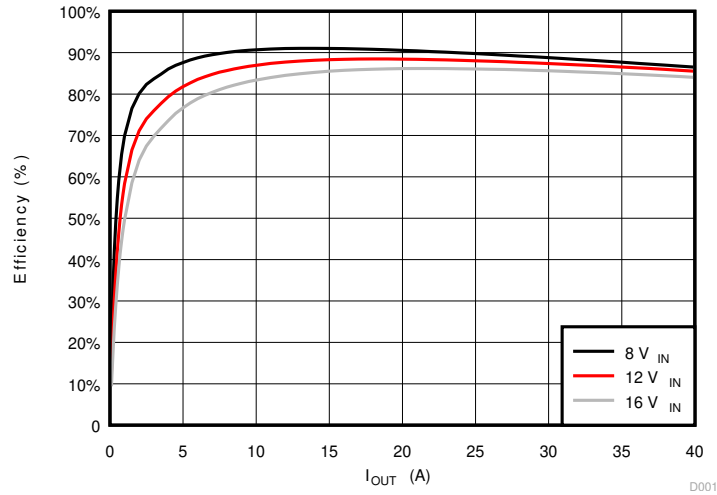

Figure 9-1. Efficiency of 1-V Output vs Load

### 9.2 Load Regulation

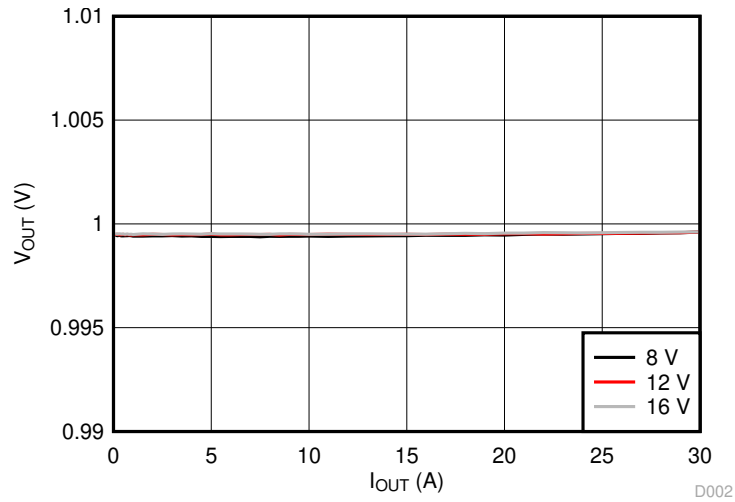

Figure 9-2. Load Regulation of 1-V Output

### 9.3 Line Regulation

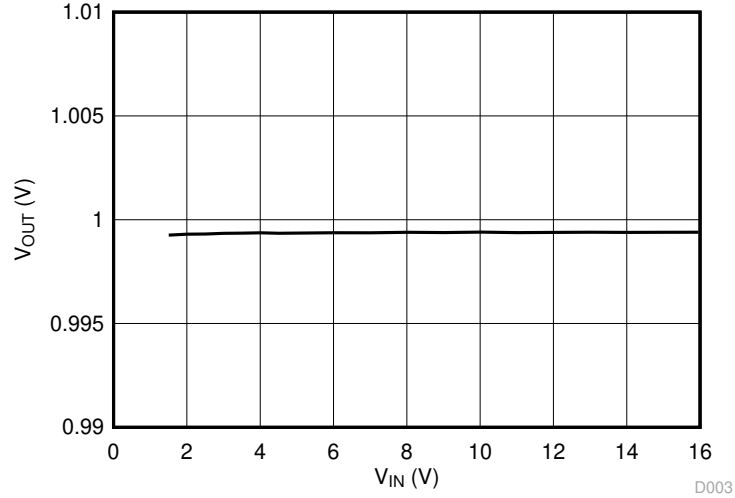

Figure 9-3. Line Regulation of 1-V Output

### 9.4 Transient Response

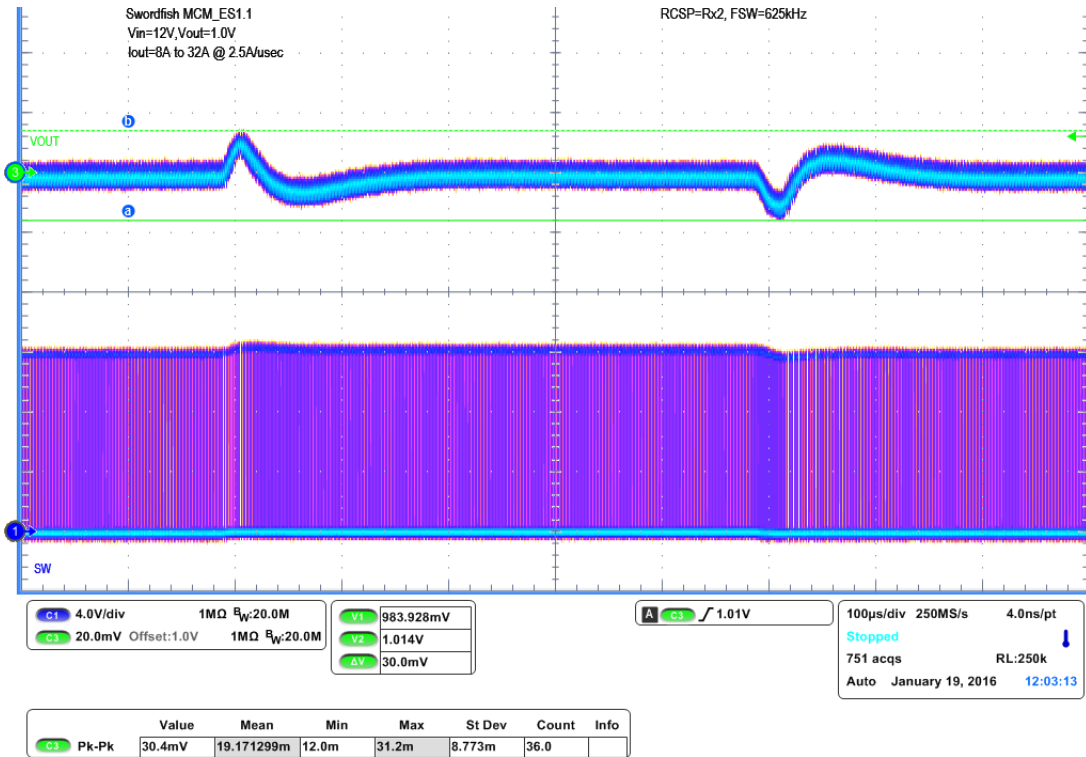

Figure 9-4. Transient Response of 1-V Output at 12 V<sub>IN</sub>, Transient is 8 A to 32 A, 2.5 A/μs

## 9.5 Output Ripple

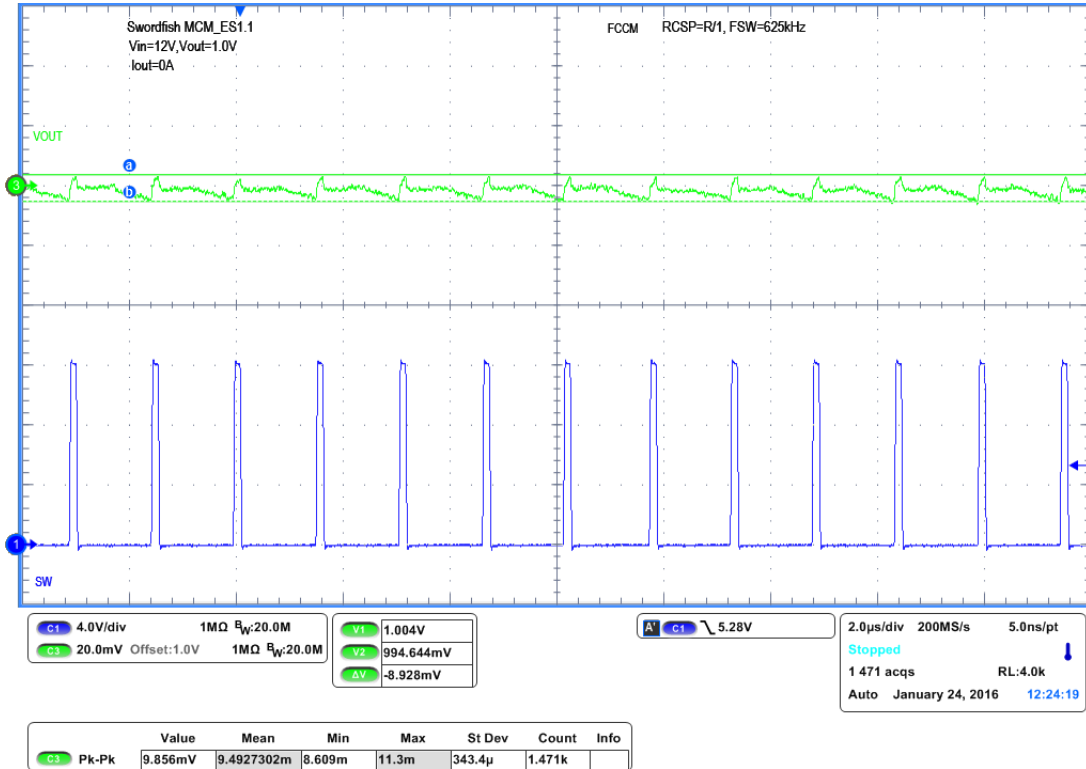

Figure 9-5. Output Ripple and SW Node of 1-V Output at 12 V<sub>IN</sub>, 0-A Output

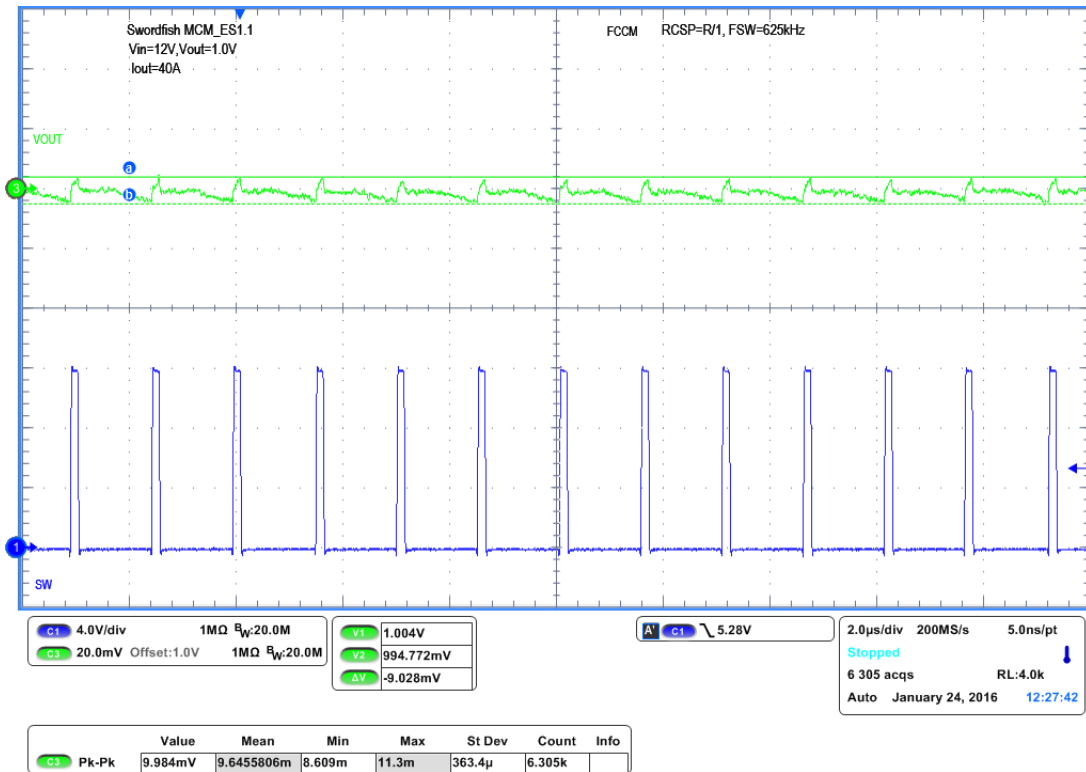

Figure 9-6. Output Ripple and SW Node of 1-V Output at 12 V<sub>IN</sub>, 40-A Output

## 9.6 Control On

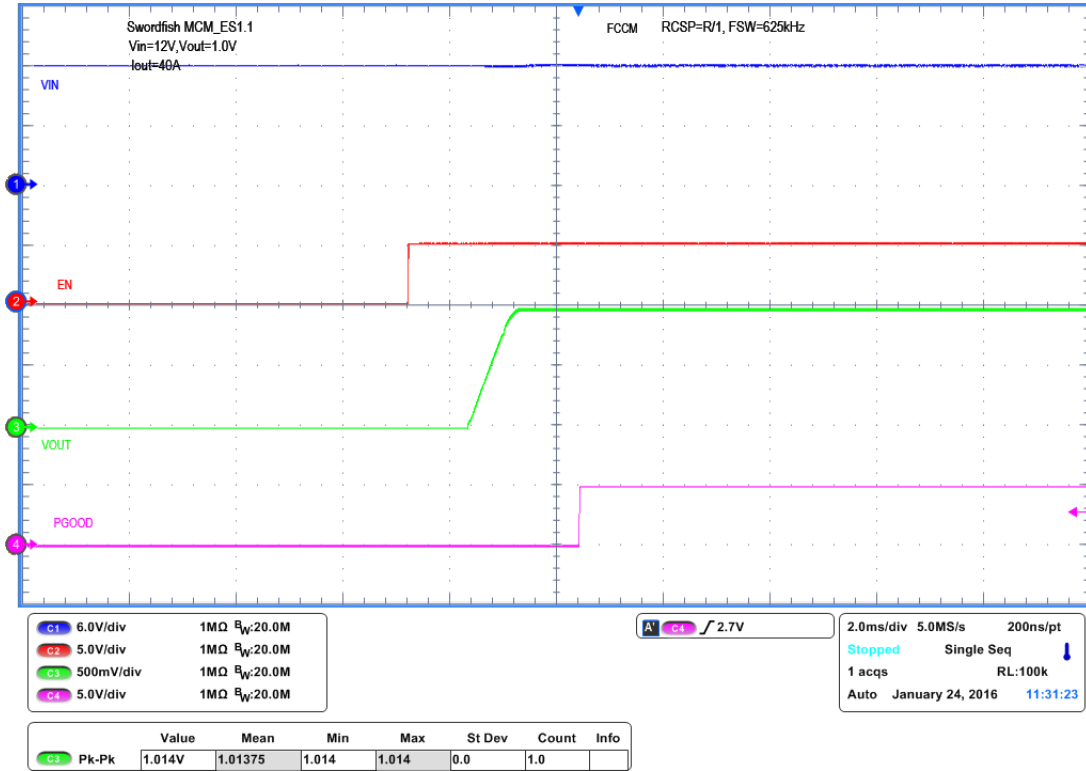

Figure 9-7. Start up from Control, 1-V Output at 12 V<sub>IN</sub>, 40-A Output

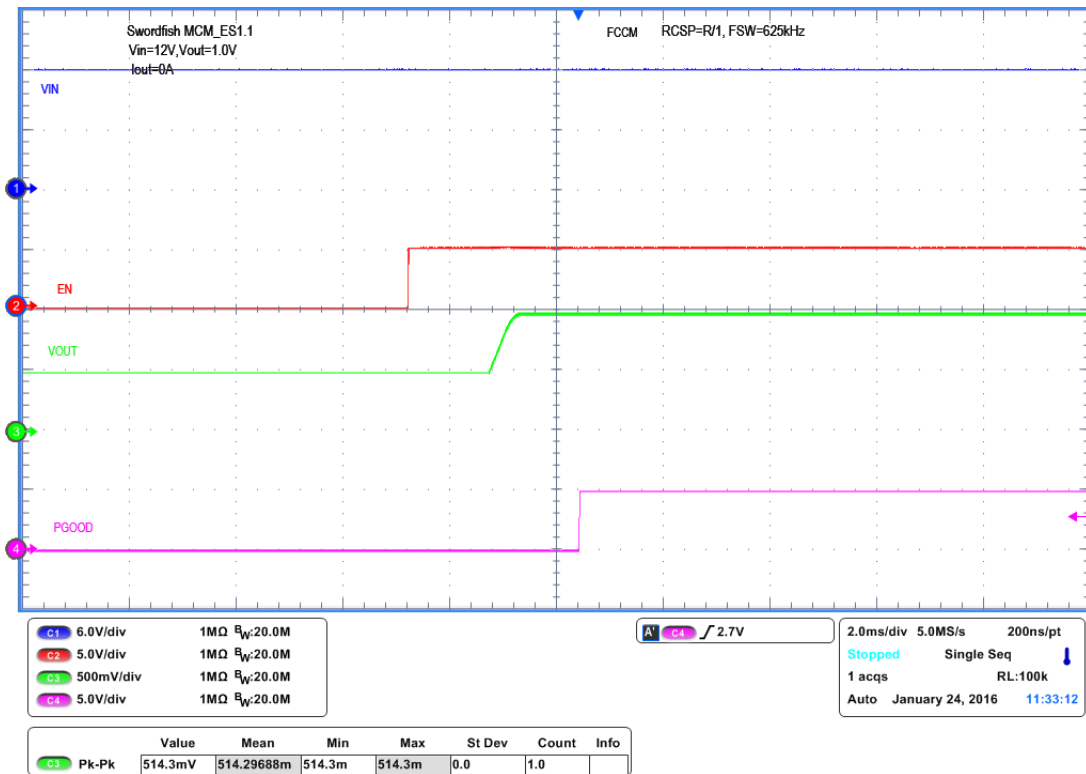

Figure 9-8. 0.5-V Pre-bias start up from Control, 1-V Output at 12 V<sub>IN</sub>, 40-A Output

### 9.7 Control Off

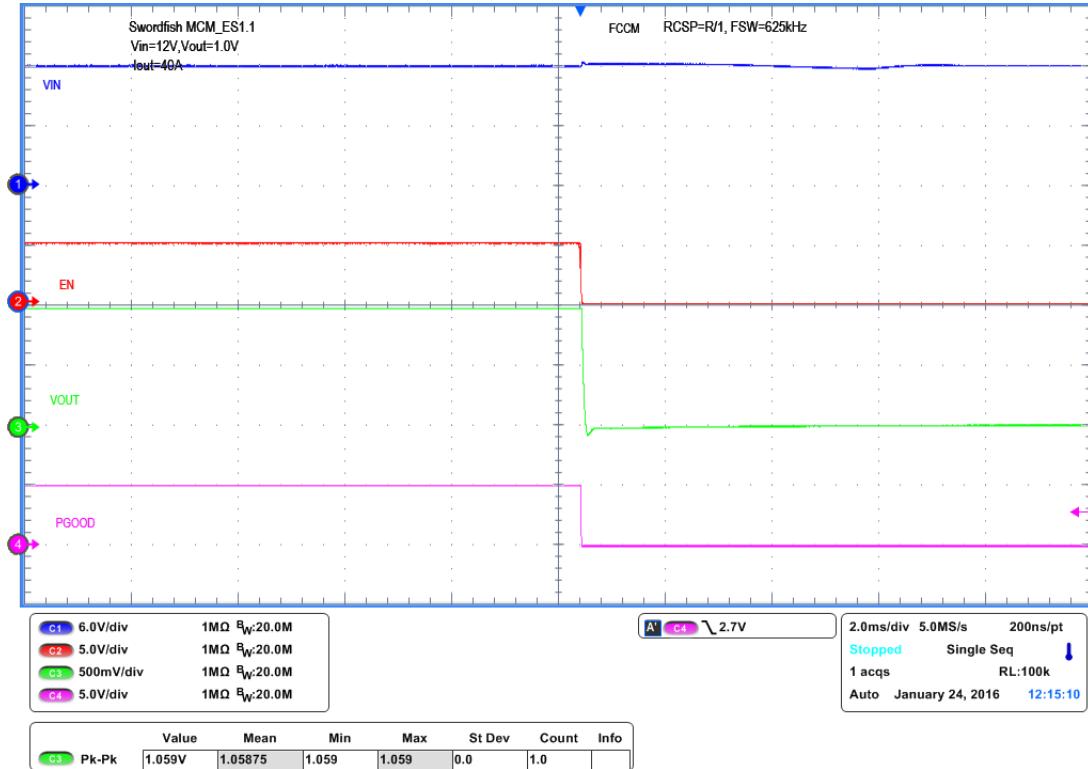

Figure 9-9. Soft Stop from Control, 1-V Output at 12 V<sub>IN</sub>, 40-A Output

### 9.8 Thermal Image

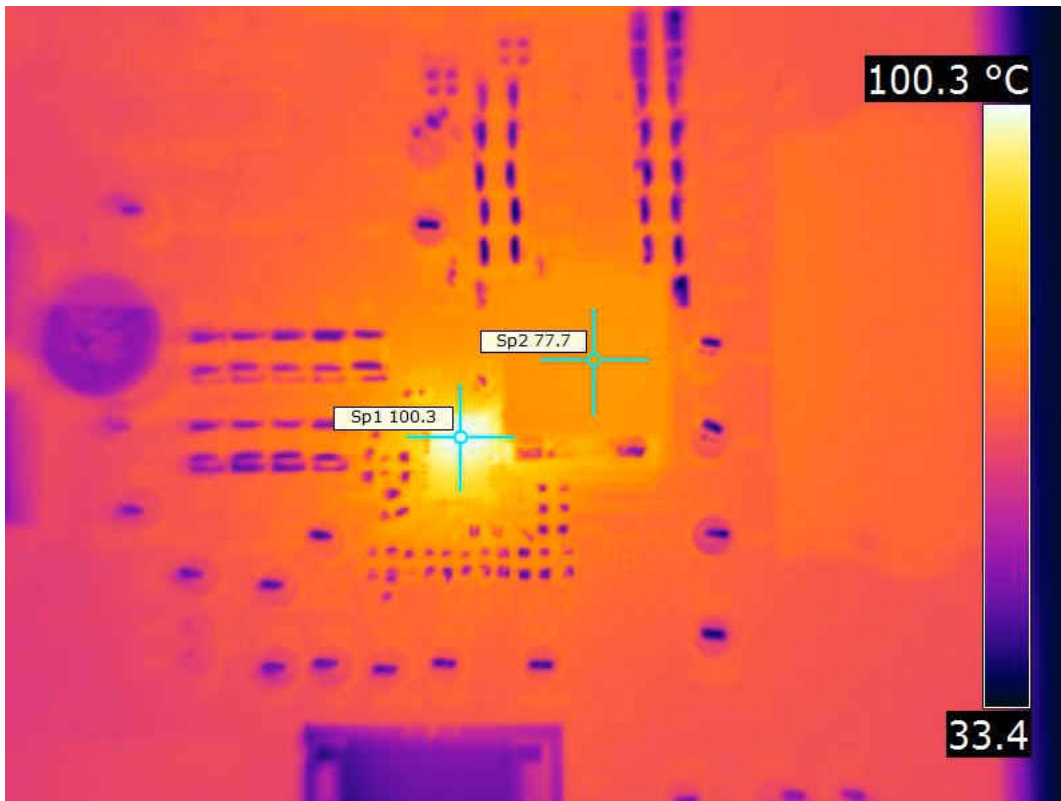

Figure 9-10. Thermal Image at 1-V Output at 12 V<sub>IN</sub>, 40-A Output

## 10 EVM Assembly Drawing and PCB Layout

Figure 10-1 through Figure 10-8 show the design of the PWR-784EVM printed-circuit board (PCB). The PWR-784EVM has a 2-oz. copper finish for all layers.

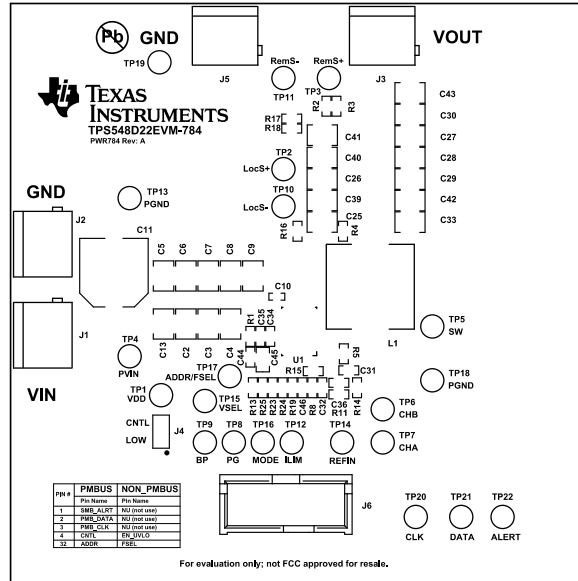

Figure 10-1. PWR-681EVM Top Layer Assembly Drawing (top view)

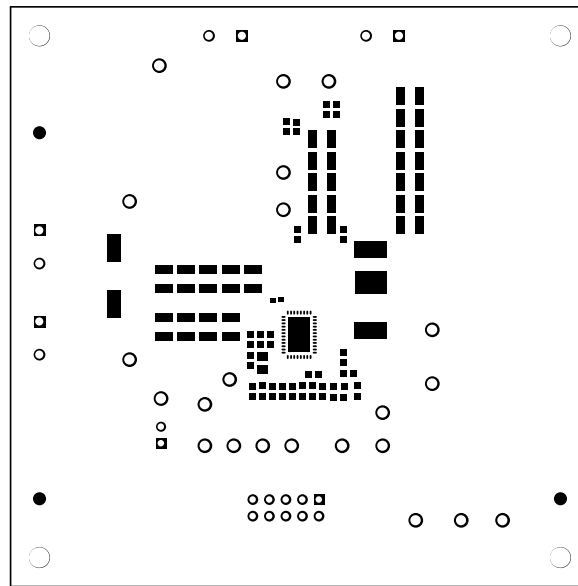
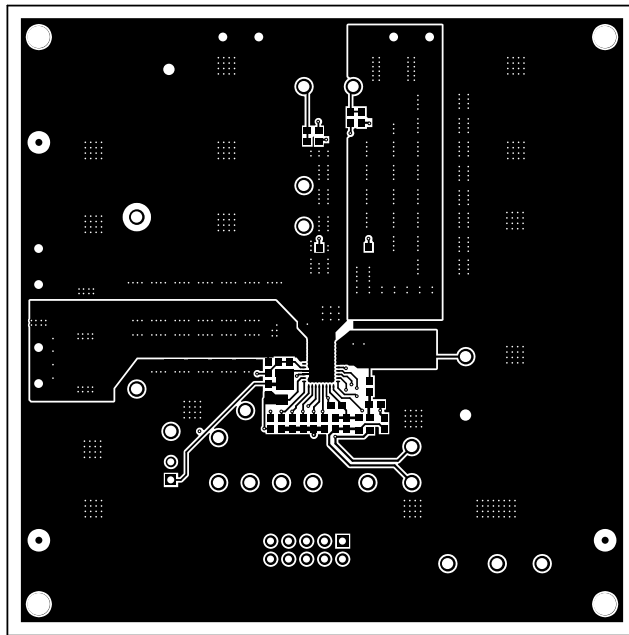
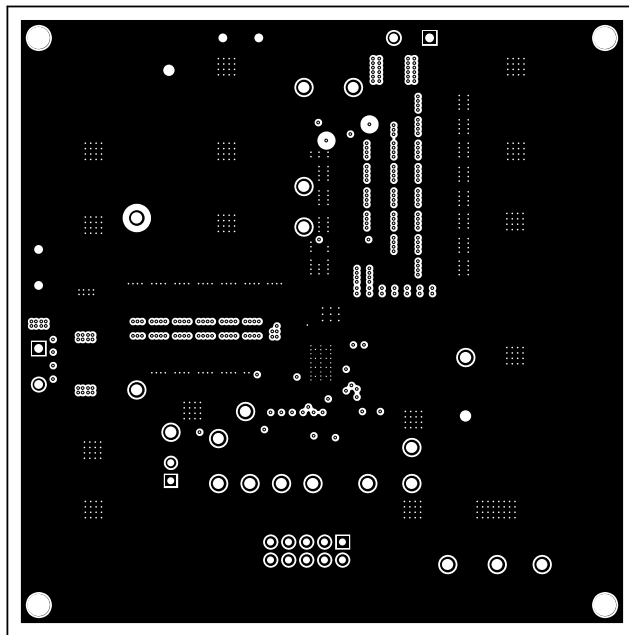

Figure 10-2. PWR-784EVM Top Solder Mask (top view)



**Figure 10-3. PWR-784EVM Top Layer (top view)**



**Figure 10-4. PWR-784EVM Inner Layer 1 (top view)**



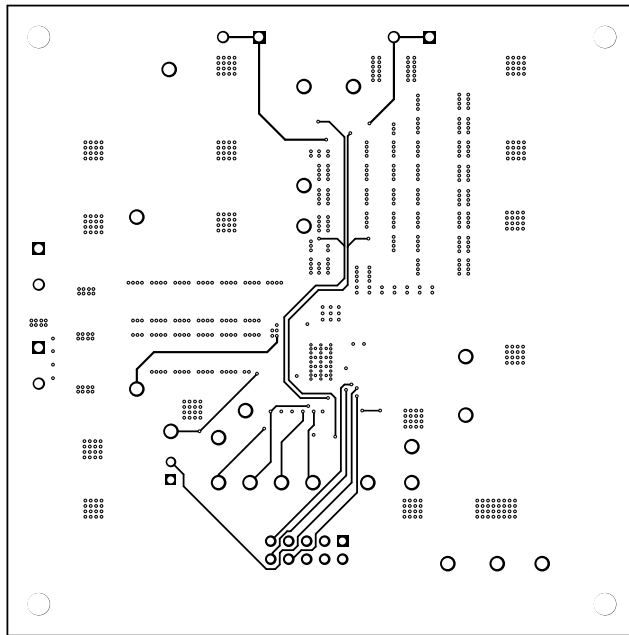

Figure 10-5. PWR-784EVM Inner Layer 2 (top view)

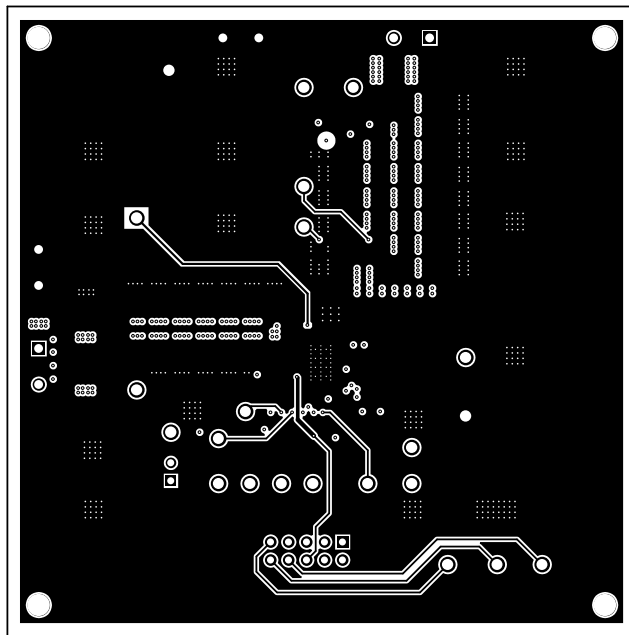
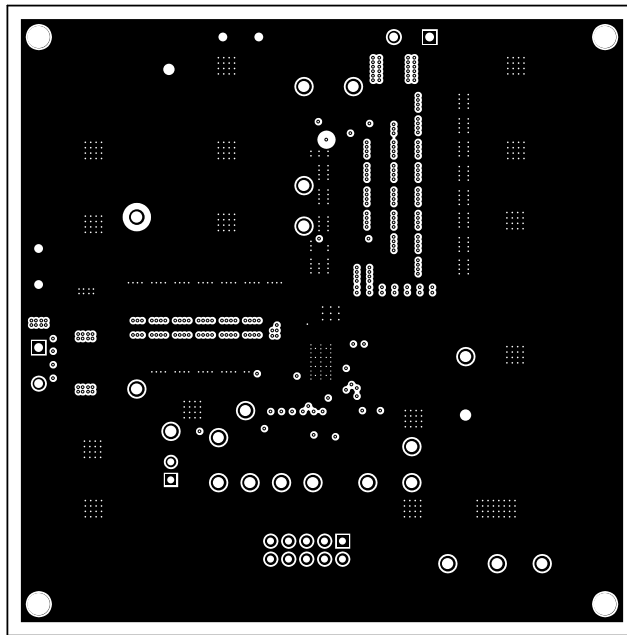
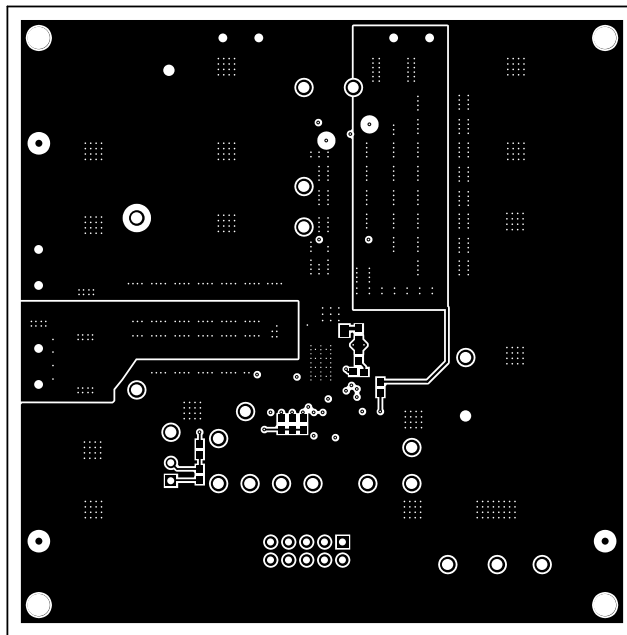

Figure 10-6. PWR-784EVM Inner Layer 3 (top view)



**Figure 10-7. PWR-784EVM Inner Layer 4 (top view)**



**Figure 10-8. PWR-784EVM Bottom Layer (top view)**

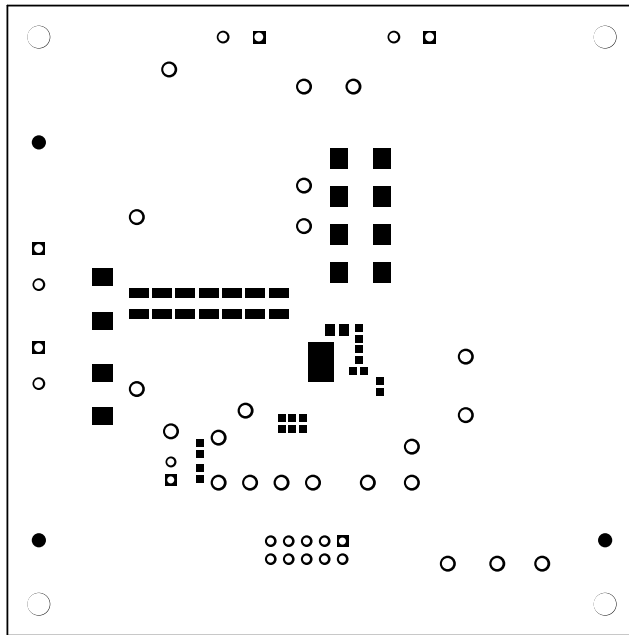

Figure 10-9. PWR-784EVM Bottom Solder Mask (top view)

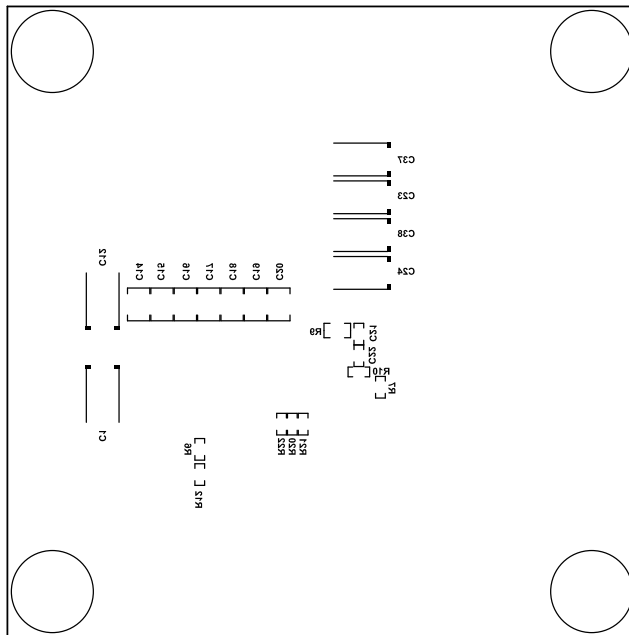

Figure 10-10. PWR-784EVM Bottom Overlay Layer (top view)

## 11 List of Materials

The EVM components list according to the schematic shown in [Table 11-1](#).

**Table 11-1. PWR784 List of Materials**

Quantity	Designator	Value	Description	Package Reference	Manufacturer	Part Number
12	C2, C3, C4, C5, C6, C7, C8, C9, C13, C18, C19, C20	22 $\mu$ F	CAP, CERM, 22 $\mu$ F, 25 V, +/- 10%, X7R, 1210	1210	MuRata	GRM32ER71E226KE15L
1	C10	2200 pF	CAP, CERM, 2200 pF, 25 V, +/- 10%, X5R, 0402	0402	MuRata	GRM155R61E222KA01D
1	C11	100 $\mu$ F	CAP, AL, 100 $\mu$ F, 35V, +/-20%, 0.15 ohm, SMD	SMT Radial G	Panasonic	EEE-FC1V101P
1	C22	0.1 $\mu$ F	CAP, CERM, 0.1 $\mu$ F, 50 V, +/- 10%, X7R, 0603	0603	MuRata	GRM188R71H104KA93D
3	C23, C24, C38	470 $\mu$ F	CAP, Tantalum Polymer, 470 $\mu$ F, 2.5 V, +/- 20%, 0.006 ohm, 7.3x2.8x4.3mm SMD	7.3x2.8x4.3mm	Panasonic	2R5TPF470M6L
10	C25, C26, C27, C28, C29, C33, C39, C40, C41, C42	100 $\mu$ F	CAP, CERM, 100 $\mu$ F, 6.3 V, +/- 20%, X5R, 1210	1210	MuRata	GRM32ER60J107ME20L
1	C35	1 $\mu$ F	CAP, CERM, 1 $\mu$ F, 16 V, +/- 10%, X5R, 0603	0603	Kemet	C0603C105K4PACTU
1	C45	4.7 $\mu$ F	CAP, CERM, 4.7 $\mu$ F, 16 V, +/- 10%, X7R, 0805	0805	MuRata	GRM21BR71C475KA73L
1	C46	1000 pF	CAP, CERM, 1000 pF, 50 V, +/- 5%, C0G/NP0, 0603	0603	Kemet	C0603C102J5GACTU
4	J1, J2, J3, J5		TERMINAL BLOCK 5.08MM VERT 2POS, TH	TERM_BLK, 2pos, 5.08mm	On-Shore Technology	ED120/2DS
1	J4		Header, 100mil, 2x1, Tin, TH	Header, 2 PIN, 100mil, Tin	Sullins Connector Solutions	PEC02SAAN
1	L1	250 nH	Inductor, Shielded Drum Core, Ferrite, 250 nH, 50 A, 0.000165 ohm, SMD	12.5x13mm	Würth Elektronik	744309025
1	R1	1.00	RES, 1.00, 1%, 0.1 W, 0603	0603	Yageo America	RC0603FR-071RL
5	R4, R7, R10, R11, R16	0	RES, 0, 5%, 0.1 W, 0603	0603	Vishay-Dale	CRCW06030000Z0EA
1	R6	200 k	RES, 200 k, 1%, 0.1 W, 0603	0603	Vishay-Dale	CRCW0603200KFKEA
1	R8	1.10 k	RES, 1.10 k, 1%, 0.1 W, 0603	0603	Vishay-Dale	CRCW06031K10FKEA
5	R12, R13, R20, R21, R22	100 k	RES, 100 k, 1%, 0.1 W, 0603	0603	Vishay-Dale	CRCW0603100KFKEA
1	R15	10.0 k	RES, 10.0k ohm, 1%, 0.1W, 0603	0603	Vishay-Dale	CRCW060310K0FKEA
1	R19	137 k	RES, 137 k, 1%, 0.1 W, 0603	0603	Vishay-Dale	CRCW0603137KFKEA
1	R23	37.4 k	RES, 37.4 k, 1%, 0.1 W, 0603	0603	Vishay-Dale	CRCW060337K4FKEA
1	R24	42.2 k	RES, 42.2 k, 1%, 0.1 W, 0603	0603	Vishay-Dale	CRCW060342K2FKEA
1	R25	22.1 k	RES, 22.1 k, 1%, 0.1 W, 0603	0603	Vishay-Dale	CRCW060322K1FKEA
14	TP1, TP5, TP6, TP7, TP8, TP9, TP12, TP14, TP15, TP16, TP17, TP20, TP21, TP22	White	Test Point, Multipurpose, White, TH	White Multipurpose Testpoint	Keystone	5012
3	TP2, TP3, TP4	Red	Test Point, Multipurpose, Red, TH	Red Multipurpose Testpoint	Keystone	5010
5	TP10, TP11, TP13, TP18, TP19	Black	Test Point, Multipurpose, Black, TH	Black Multipurpose Testpoint	Keystone	5011
1	U1		High Performance, 40-A Single Synchronous Step-Down Converter with Analog REFIN, RVF0040A	RVF0040A	Texas Instruments	TPS548C22RVF
0	C1, C12	330 $\mu$ F	CAP, TA, 330 $\mu$ F, 6.3 V, +/- 20%, 0.025 ohm, SMD	7.3x2.8x4.3mm	Sanyo	6TPE330ML
0	C14, C15, C16, C17	22 $\mu$ F	CAP, CERM, 22 $\mu$ F, 25 V, +/- 10%, X7R, 1210	1210	MuRata	GRM32ER71E226KE15L

**Table 11-1. PWR784 List of Materials (continued)**

Quantity	Designator	Value	Description	Package Reference	Manufacturer	Part Number
0	C21	470 pF	CAP, CERM, 470 pF, 50 V, +/- 10%, X7R, 0603	0603	MuRata	GRM188R71H471KA01D
0	C30, C43	100 µF	CAP, CERM, 100 µF, 6.3 V, +/- 20%, X5R, 1210	1210	MuRata	GRM32ER60J107ME20L
0	C31	0.1 µF	CAP, CERM, 0.1 µF, 50 V, +/- 10%, X7R, 0603	0603	MuRata	GRM188R71H104KA93D
0	C32	6800 pF	CAP, CERM, 6800 pF, 50 V, +/- 10%, X7R, 0603	0603	MuRata	GRM188R71H682KA01D
0	C34, C44	1 µF	CAP, CERM, 1 µF, 16 V, +/- 10%, X5R, 0603	0603	Kemet	C0603C105K4PACTU
0	C36	1000 pF	CAP, CERM, 1000 pF, 25 V, +/- 10%, X7R, 0603	0603	MuRata	GRM188R71E102KA01D
0	C37	470 µF	CAP, Tantalum Polymer, 470 µF, 2.5 V, +/- 20%, 0.006 ohm, 7.3x2.8x4.3mm SMD	7.3x2.8x4.3mm	Panasonic	2R5TPF470M6L
0	J6		Header (shrouded), 100mil, 5x2, Gold, TH	5x2 Shrouded header	TE Connectivity	5103308-1
0	R2, R3, R14, R17, R18	0	RES, 0, 5%, 0.1 W, 0603	0603	Vishay-Dale	CRCW06030000Z0EA
0	R5	1.50 k	RES, 1.50 k, 1%, 0.1 W, 0603	0603	Yageo America	RC0603FR-071K5L
0	R9	3.0 1	RES, 3.01 ohm, 1%, 0.125W, 0805	0805	Vishay-Dale	CRCW08053R01FKEA

## 12 Revision History

NOTE: Page numbers for previous revisions may differ from page numbers in the current version.

### Changes from Revision A (February 2016) to Revision B (August 2021)

Page

- Updated user's guide title..... 3
- Updated the numbering format for tables, figures, and cross-references throughout the document. ....3

## IMPORTANT NOTICE AND DISCLAIMER

TI PROVIDES TECHNICAL AND RELIABILITY DATA (INCLUDING DATA SHEETS), DESIGN RESOURCES (INCLUDING REFERENCE DESIGNS), APPLICATION OR OTHER DESIGN ADVICE, WEB TOOLS, SAFETY INFORMATION, AND OTHER RESOURCES "AS IS" AND WITH ALL FAULTS, AND DISCLAIMS ALL WARRANTIES, EXPRESS AND IMPLIED, INCLUDING WITHOUT LIMITATION ANY IMPLIED WARRANTIES OF MERCHANTABILITY, FITNESS FOR A PARTICULAR PURPOSE OR NON-INFRINGEMENT OF THIRD PARTY INTELLECTUAL PROPERTY RIGHTS.

These resources are intended for skilled developers designing with TI products. You are solely responsible for (1) selecting the appropriate TI products for your application, (2) designing, validating and testing your application, and (3) ensuring your application meets applicable standards, and any other safety, security, regulatory or other requirements.

These resources are subject to change without notice. TI grants you permission to use these resources only for development of an application that uses the TI products described in the resource. Other reproduction and display of these resources is prohibited. No license is granted to any other TI intellectual property right or to any third party intellectual property right. TI disclaims responsibility for, and you will fully indemnify TI and its representatives against, any claims, damages, costs, losses, and liabilities arising out of your use of these resources.

TI's products are provided subject to [TI's Terms of Sale](#) or other applicable terms available either on [ti.com](http://ti.com) or provided in conjunction with such TI products. TI's provision of these resources does not expand or otherwise alter TI's applicable warranties or warranty disclaimers for TI products.

TI objects to and rejects any additional or different terms you may have proposed.

Mailing Address: Texas Instruments, Post Office Box 655303, Dallas, Texas 75265  
Copyright © 2022, Texas Instruments Incorporated