

**ABSTRACT**

This user's guide describes the characteristics, operation, and use of the TPS92519-Q1 dual 2-A synchronous high current buck LED driver evaluation module (EVM). A complete schematic diagram, printed-circuit board layouts, and bill of materials are included in this document.

Table of Contents

1 Introduction	3
2 Warnings and Cautions	3
3 Description	4
3.1 Typical Applications.....	4
3.2 Features.....	4
3.3 Connector and Test Point Description.....	4
3.4 Electrical Performance Specifications.....	11
4 Test Setup	12
4.1 Input Supplies and LED Load Connections.....	12
4.2 Switching Frequency Selection.....	14
4.3 Analog Dimming Using IADJx.....	14
4.4 PWM Dimming Using UDIMx and PWM Test Points.....	15
5 Performance Data and Typical Characteristic Curves	17
5.1 Efficiency.....	17
5.2 Analog Dimming.....	17
5.3 PWM Dimming.....	18
5.4 PWM Dimming Waveforms.....	18
6 Schematic	22
7 TPS92519EVM-169 PCB Layout	24
8 Bill of Materials	26
9 Revision History	27

List of Figures

Figure 3-1. TPS92519EVM-169 Top View – EVM Functions and Features.....	5
Figure 3-2. TPS92519EVM-169 Bottom View – EVM Functions and Features.....	5
Figure 3-3. TPS92519EVM-169 Connector Numbers and Locations.....	6
Figure 3-4. TPS92519EVM-169 Test point Numbers and Locations.....	7
Figure 4-1. TPS92519EVM-169 Typical Test Setup.....	12
Figure 4-2. V5D, VINx and LEDx Connections.....	13
Figure 4-3. FSET Resistors and Circuit.....	14
Figure 4-4. Channel 1 IADJ Using External Supply.....	14
Figure 4-5. Channel 2 IADJ Using External Supply.....	14
Figure 4-6. Setting IADJx Using On-Board Resistor Divider.....	15
Figure 4-7. IADJ Using Resistor Divider.....	15
Figure 4-8. PWM Dimming Using PWM1 and PWM2.....	16
Figure 4-9. PWM Dimming Using UDIM1 and UDIM2.....	16
Figure 5-1. Efficiency vs. Output Current.....	17
Figure 5-2. Output Current vs IADJ Voltage 48-V Input, 2 LEDs.....	17
Figure 5-3. Output Current vs. PWM Duty Cycle (250 Hz) 48-V Input, 2 LEDs.....	18
Figure 5-4. 1% Duty Cycle 250-Hz PWM Dimming Top = V_{SW} , Middle = V_{PWM} , Bottom = LED Current, Input Voltage = 48 V, 2 LEDs.....	18
Figure 5-5. 50% Duty Cycle, 250-Hz PWM Dimming Top = V_{SW} , Middle = V_{PWM} , Bottom = LED Current, Input Voltage = 48 V, 2 LEDs.....	19

Figure 5-6. 99% Duty Cycle, 250-Hz PWM Dimming Top = V_{SW} , Middle = V_{PWM} , Bottom = LED Current, Input Voltage = 14 V, 2 LEDs.....	19
Figure 5-7. 1% Duty Cycle, 250-Hz PWM Dimming Top = V_{SW} , Middle = V_{PWM} , Bottom = LED Current, Input Voltage = 48 V, 4 LEDs.....	20
Figure 5-8. 50% Duty Cycle, 250-Hz PWM Dimming Top = V_{SW} , Middle = V_{PWM} , Bottom = LED Current, Input Voltage = 48 V, 4 LEDs.....	20
Figure 5-9. 99% Duty Cycle, 250-Hz PWM Dimming Top = V_{SW} , Middle = V_{PWM} , Bottom = LED Current, Input Voltage = 48 V, 4 LEDs.....	21
Figure 6-1. TPS92519EVM-169 Schematic Page 1.....	22
Figure 6-2. TPS92519EVM-169 Schematic Page 2.....	23
Figure 7-1. Top Layer and Top Overlay (Top View).....	24
Figure 7-2. Signal Layer 1.....	24
Figure 7-3. Signal Layer 2.....	25
Figure 7-4. Bottom Layer and Bottom Overlay (Bottom View).....	25

List of Tables

Table 3-1. Connectors.....	6
Table 3-2. Test Points.....	7
Table 3-3. TPS92519EVM Performance Specifications.....	11
Table 8-1. TPS92519EVM-169 Bill of Materials.....	26

Trademarks

All trademarks are the property of their respective owners.

1 Introduction

The TPS92519EVM-169 evaluation module (EVM) helps designers evaluate the operation and performance of the TPS92519-Q1 buck switching regulator designed for high-current LED drive applications. The TPS92519-Q1 is designed to control two drivers of high-brightness light-emitting diodes (LED) and features a wide input voltage range (5.5 V to 65 V), PWM dimming capability, analog dimming capability, and input undervoltage protection.

2 Warnings and Cautions

Observe the following precautions when using the TPS92519EVM-169.

CAUTION



Caution! Do not leave EVM powered when unattended.

HOT SURFACE:



Caution Hot Surface! Contact may cause burns. Do not touch. Please take the proper precautions when operating.

HIGH VOLTAGE:



Danger High Voltage! Electric shock possible when connecting board to live wire. Board must be handled with care by a professional. For safety, use of isolated test equipment with overvoltage and overcurrent protection is highly recommended.

WARNING



When choosing your LED component (not included with this EVM), the end user must consult the LED data sheet supplied by the LED manufacturer to identify the EN62471 Risk Group Rating and review any potential eye hazards associated with the LED chosen. Always consider and implement the use of effective light filtering and darkening protective eye wear and be fully aware of surrounding laboratory-type set-ups when viewing intense light sources that can be required to minimize or eliminate such risks in order to avoid accidents related to temporary blindness.

3 Description

This user's guide describes the specifications, board connection descriptions, characteristics, operation, and use of the TPS92519-Q1, dual 2.0-A synchronous buck LED driver evaluation module (TPS92519EVM-169). The TPS92519-Q1 device implements an adaptive on-time average current mode control and is designed to be compatible with shunt FET dimming techniques and LED matrix manager-based dynamic beam headlamps. The adaptive on-time control provides near constant switching frequency that can be set to 385/435 kHz or 2/2.1 MHz. Inductor current sensing and closed-loop feedback enables better than $\pm 4\%$ accuracy over wide input voltage, output voltage and ambient temperature range.

TPS92519EVM-169 provides a high-brightness LED driver that is designed to operate with an input voltage in the range of 5.5 V to 65 V. The EVM is set up for a default output current of 2 A for an LED stack between approximately 3 V and nearly 60 V operating at 385/435 kHz. The TPS92519-Q1 helps provide high efficiency, fast PWM dimming, and accurate wide-range analog dimming.

3.1 Typical Applications

This converter design describes an application of the TPS92519-Q1 as an LED driver with the specifications listed in [Table 3-3](#). For applications with a different input voltage range or different output voltage range, refer to the [TPS92519-Q1 4.5-V to 65-V Dual 2-A Synchronous Buck LED Driver Data Sheet](#).

3.2 Features

- AEC-Q100 qualified for automotive applications
 - Grade 1: -40°C to 125°C ambient operating temperature
 - Device HBM classification level H1C
 - Device CDM classification level C2
- Up to 2-A output current with 4% accuracy
- AEC-Q100 qualified for automotive applications
 - Grade 1: -40°C to 125°C ambient operating temperature
 - Device HBM classification level H1C
 - Device CDM classification level C2
- Up to 2-A output current with 4% accuracy
- Cycle-by-cycle switch overcurrent protection
- Nominal switching frequency
 - 385-kHz / 435-kHz for channel 1 and channel 2
 - 2-MHz / 2.1MHz for channel 1 and channel 2
- 4.5-V to 65-V wide input voltage range
- Adaptive on-time average current control
- LED open and short fault monitoring and reporting
- Switch thermal protection
- Functional Safety-Capable
- 4.5-V to 65-V wide input voltage range
- Adaptive on-time average current control
- LED open and short fault monitoring and reporting
- Switch thermal protection
- Functional Safety-Capable - Documentation available to aid functional safety system design
- Advanced dimming operation
 - Precision analog dimming
 - Supports external PWM dimming input
 - Optimized for external shunt dimming including LED Matrix Manager

3.3 Connector and Test Point Description

This section describes the connectors and test points on the EVM and how to properly connect, setup, and use the TPS92519EVM-169.

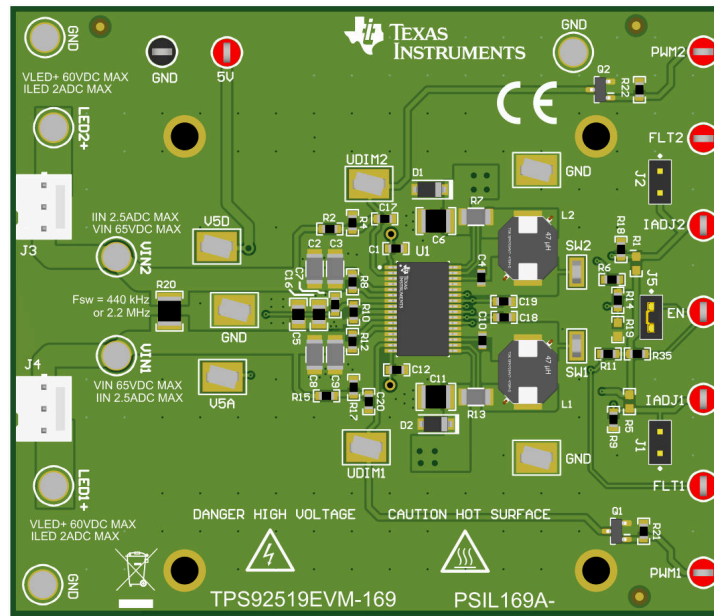

Figure 3-1. TPS92519EVM-169 Top View – EVM Functions and Features

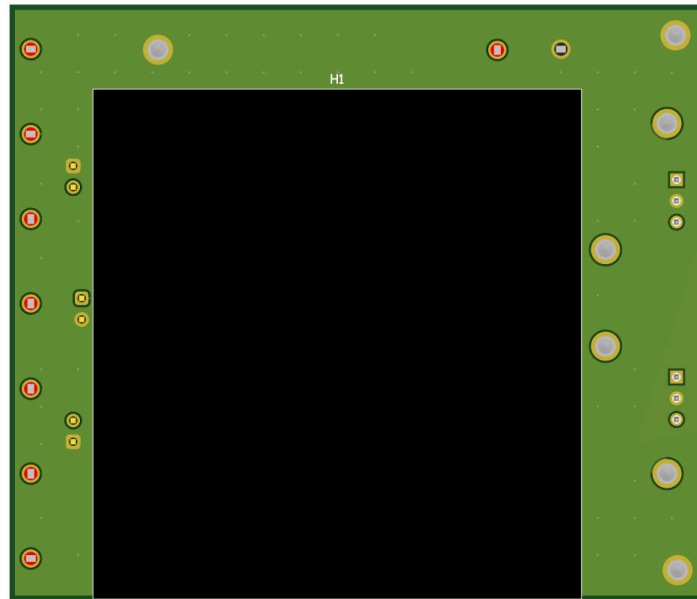

Figure 3-2. TPS92519EVM-169 Bottom View – EVM Functions and Features

Description

This section describes the connectors, names, and descriptions.

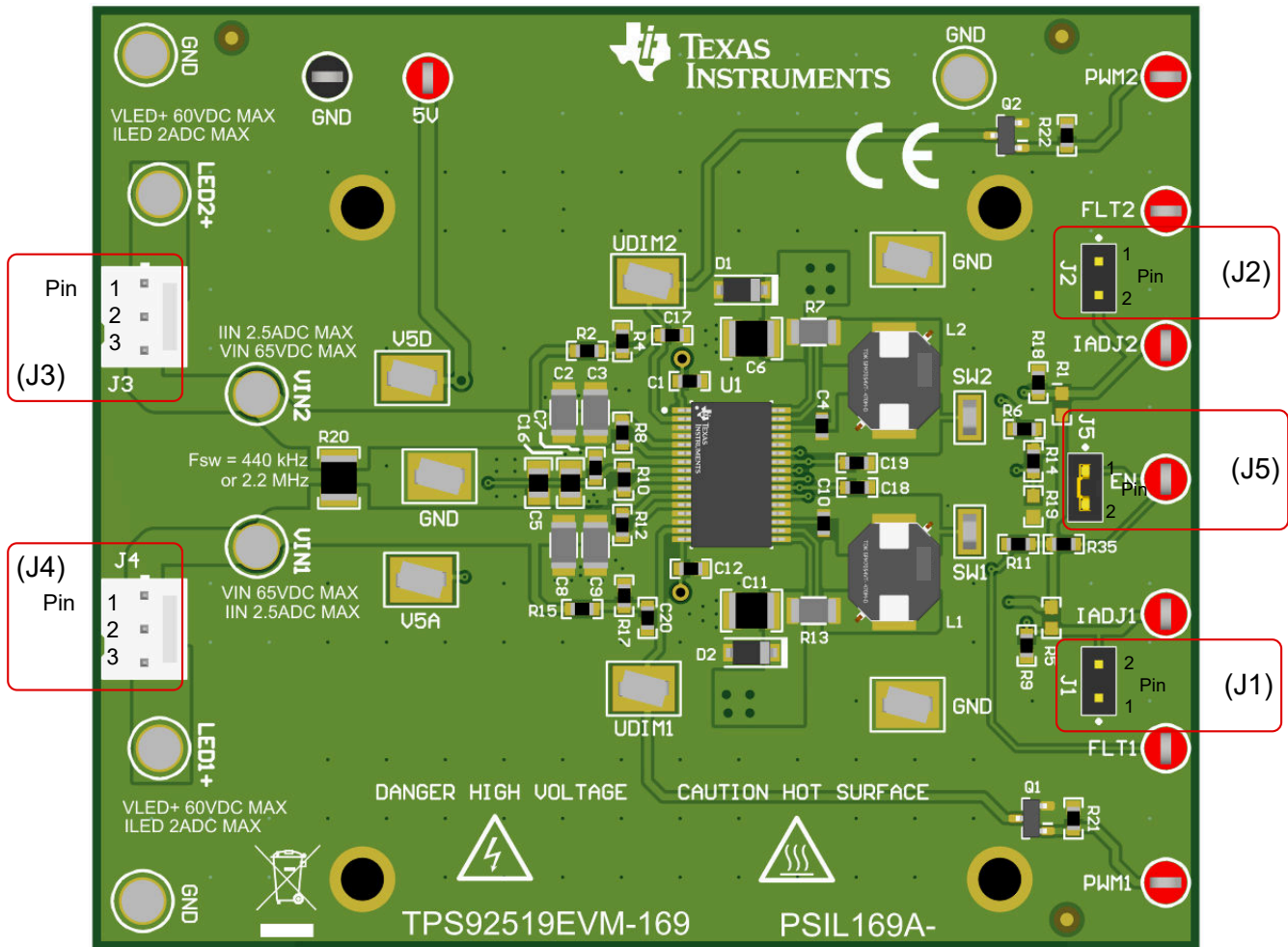

Figure 3-3. TPS9259EVM-169 Connector Numbers and Locations

Table 3-1. Connectors

Connector	Description
J1	This connector is used in conjunction with a shunt to disable channel 1. Note this connector is designed to be used when R5 is loaded to create a resistor divider with V5D. If an external supply is used to provide the voltage to IADJ pin, then the shunt shorts the supply when inserted.
J2	This connector is used in conjunction with a shunt to disable channel 2. Note this connector is designed to be used when R1 is loaded to create a resistor divider with V5D. If an external supply is used to provide the voltage to IADJ pin, then the shunt shorts the supply when inserted.
J3	This connector allows for creating a connector that mates to J3, where pin 1 is LED2+, pin 2 is GND, and pin 3 is VIN2.
J4	This connector allows for creating a connector that mates to J4, where pin 1 is VIN1, pin 2 is GND, and pin 3 is LED1+.
J5	J5 is used in conjunction with a shunt to disable both channels and the device is put into sleep mode.

This section describes the test points, names, and descriptions.

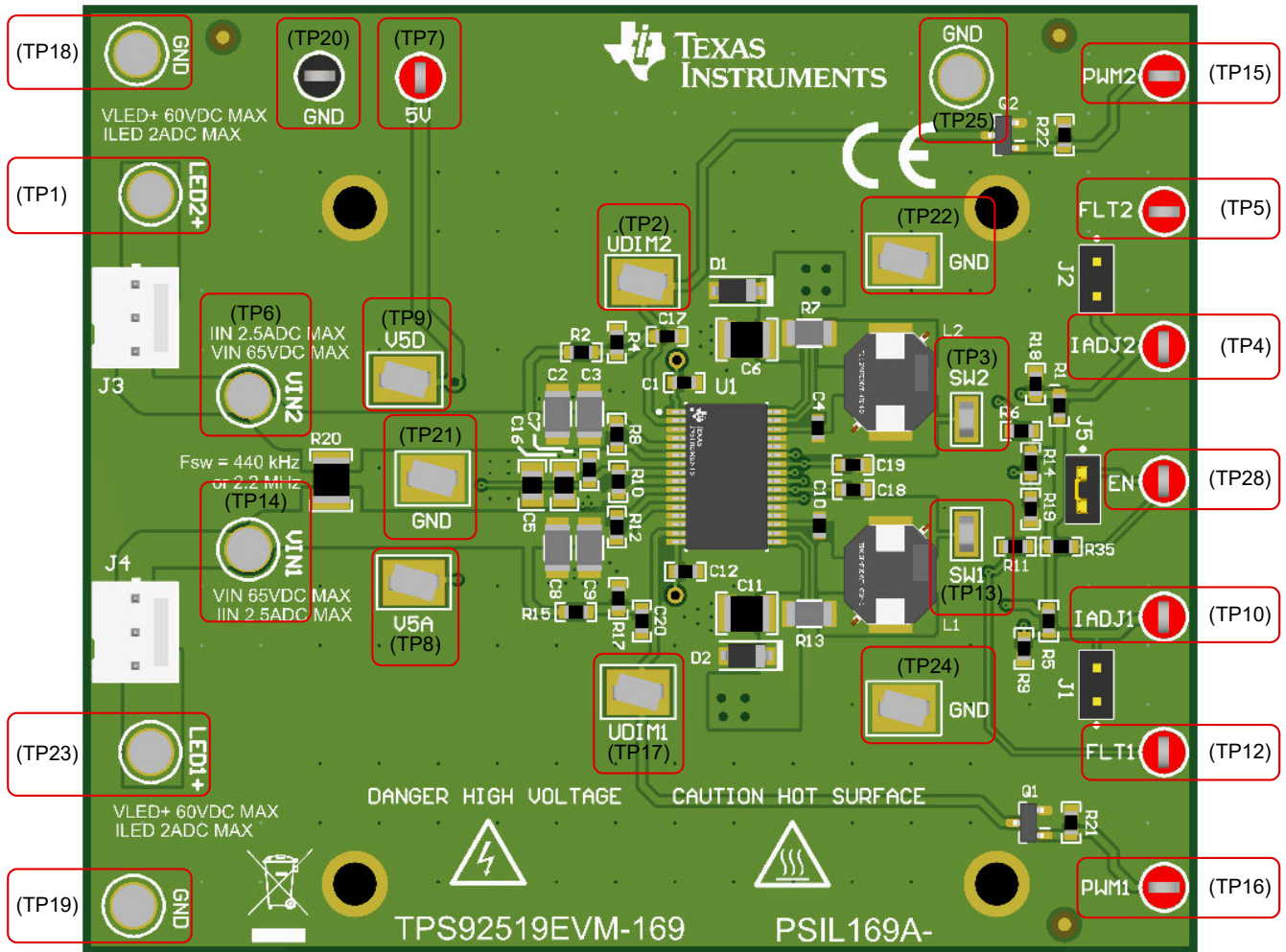

Figure 3-4. TPS9259EVM-169 Test point Numbers and Locations

Table 3-2. Test Points

Test Point	Description
GND (TP11, TP18, TP19, TP20, TP21, TP22, TP24)	Larger metal turrets and test points allow for multiple connection to grounds across the board.
VIN1 (TP14)	The VIN1 test point allows for voltage and current measurement of the power applied to the VIN1 pin of the TPS92519-Q1. R20 is by default loaded and connects VIN1 to VIN2 and must be removed if is desired to connect VIN1 and VIN2 separately.
VIN2 (TP6)	The VIN2 test point allows for voltage and current measurement of the power applied to the VIN2 pin of the TPS92519-Q1. R20 is by default loaded and connects VIN1 to VIN2 and must be removed if is desired to connect VIN1 and VIN2 separately.
5V (TP7)	The 5-V test point is for external 5-V supply to power both V5D and V5A when R10 is loaded.
VLED1+ (TP23)	The VLED1 test point allows for connection of the LED loads to channel-1 output. Large turrets allow for multiple connections.
VLED2+ (TP1)	The VLED2 test point allows for connection of the LED loads to channel-2 output. Large turrets allow for multiple connections.
SW1 (TP13)	The SW1 test point allows for observing the switch node for channel 1 during operation with an oscilloscope.
SW2 (TP3)	The SW2 test point allows for observing the switch node for channel 2 during operation with an oscilloscope.

Table 3-2. Test Points (continued)

Test Point	Description
5VD (TP9)	<p>V5D test point connects directly to the V5D digital pin of the TPS92519-Q1. The test point can be used to monitor the voltage or used to supply the power directly to the V5D pin. Note if doing current measurements R10 connects 5VD rail to V5A, which consumes power but can be separated by removing R10 and supplying V5A externally.</p> 
V5A (TP8)	<p>V5A test point connects directly to V5A pin of the TPS92519-Q1. This can be used to monitor the voltage or current used to supply the power directly to V5A pin assuming R10 has been removed and is applied externally. By default V5D and V5A are shorted together using R10 and the supply is provided by the 5V supply.</p>
UDIM1 (TP17)	<p>UDIM1 test point allows for the direct connection of the UDIM1 pin of the TPS92519-Q1 for PWM dimming of channel 1. Note that when UDIM1 is below 1.02 V falling the channel is disabled. Read the External PWM Dimming and Input Undervoltage Lockout (UVLO) section in the TPS92519-Q1 4.5-V to 65-V Dual 2-A Synchronous Buck LED Driver Data Sheet for additional information.</p> 
UDIM2 (TP2)	<p>UDIM2 test point allows for the direct connection of the UDIM2 pin of the TPS92519-Q1 for PWM dimming of channel 2. Note that when UDIM2 is below 1.02 V falling the channel is disabled. Read the External PWM Dimming and Input Undervoltage Lockout (UVLO) section in the TPS92519-Q1 4.5-V to 65-V Dual 2-A Synchronous Buck LED Driver Data Sheet for additional information.</p> 

Table 3-2. Test Points (continued)

Test Point	Description
PWM1 (TP16)	<p>These are the test points used to perform external PWM dimming for channel 1. UDIM1 is inverted from PWM1.</p>  
PWM2 (TP15)	<p>These are the test points used to perform external PWM dimming for channel 2. UDIM2 is inverted from PWM2.</p>  
FLT1 (TP12)	<p>The FLT1 test point can be used to monitor if a fault has occurrence in the TPS92519-Q1 on channel 1. When a fault occurs, FLT1 voltage level goes low. Read Faults and Diagnostics section of the TPS92519-Q1 4.5-V to 65-V Dual 2-A Synchronous Buck LED Driver Data Sheet to determine which faults trigger the FLT_x indication.</p>
FLT2 (TP5)	<p>The FLT2 test point can be used to monitor if a fault has occurrence in the TPS92519-Q1 on channel 2. When a fault occurs, FLT2 voltage level goes low. Read Faults and Diagnostics section of the TPS92519-Q1 4.5-V to 65-V Dual 2-A Synchronous Buck LED Driver Data Sheet to determine which faults trigger the FLT_x indication.</p>
IADJ1 (TP10)	<p>The TPS92519's LED current are controlled by applying a voltage to the IADJ1 test point. J1 can be used to disable the output by shorting the IADJ1 pin to ground. 140 mV to 2.45 V for VIADJ gives 122 mA to 2134 mA of output current. If using an external supply to IADJ1 pin then do not short the supply by loading J1.</p>  
IADJ2 (TP4)	<p>The TPS92519's LED current is controlled by applying a voltage to the IADJ2 test point. J2 can be used to disable the output by shorting the IADJ2 pin to ground. 140 mV to 2.45 V for VIADJ gives 122 mA to 2134 mA of output current. If using an external supply to IADJ2 pin then do not short the supply by loading J2.</p>  

Table 3-2. Test Points (continued)

Test Point	Description
EN (TP28)	<p>The EN test point is connected to the TPS92519 to either enable or disable the device. By default, the test point is turned on. A jumper can be applied to J5 to disable the part or the EN test point can be pulled low to disable the device.</p> 

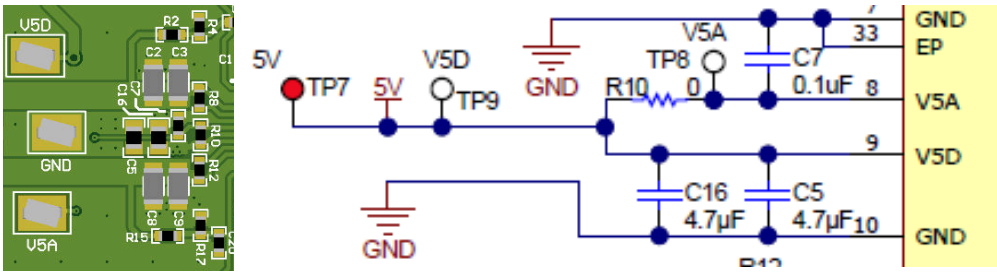
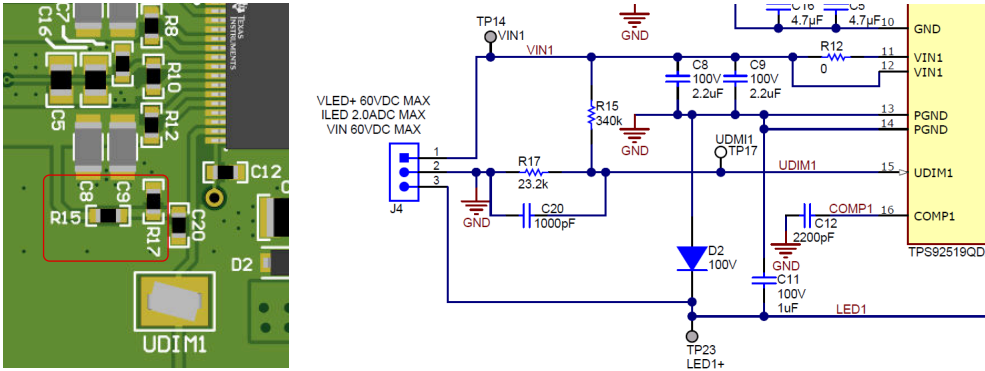
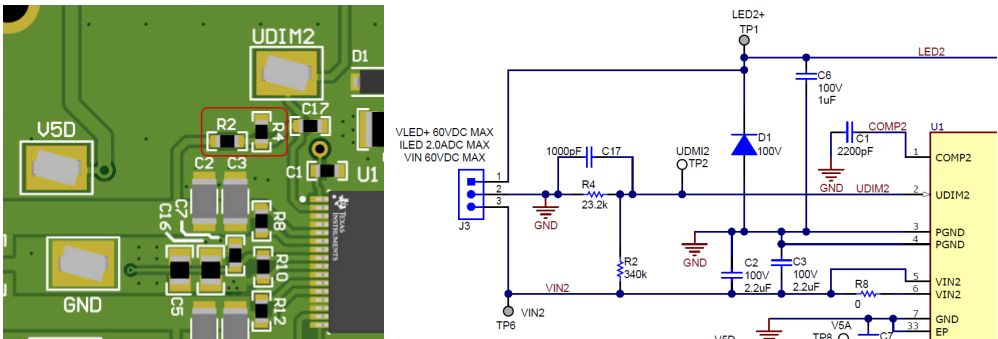
3.4 Electrical Performance Specifications

Table 3-3 lists the EVM electrical performance specifications.

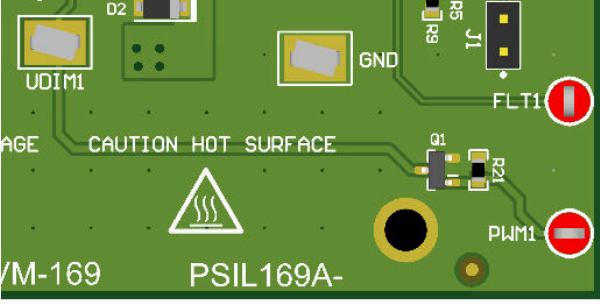
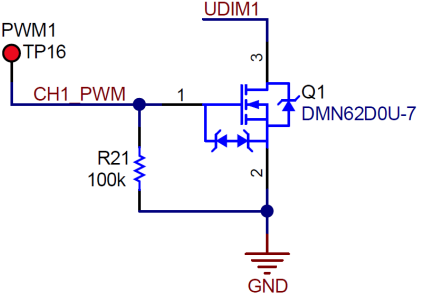
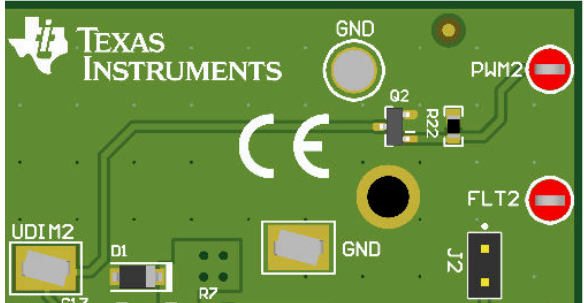
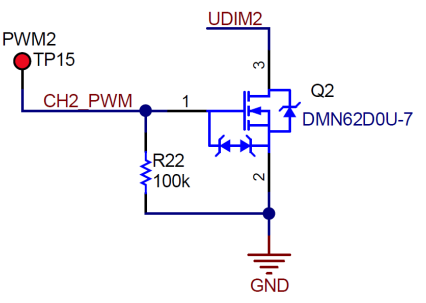
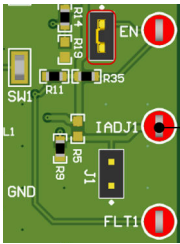
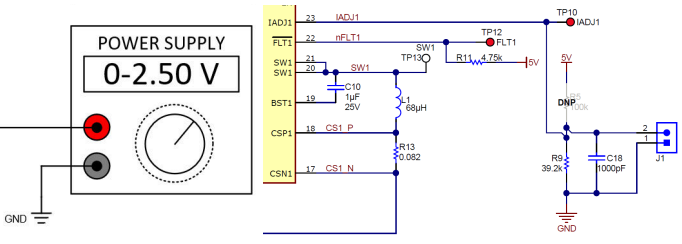
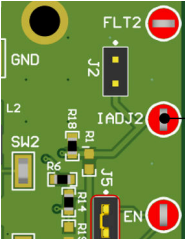
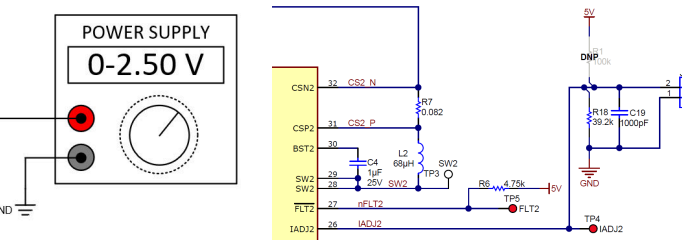
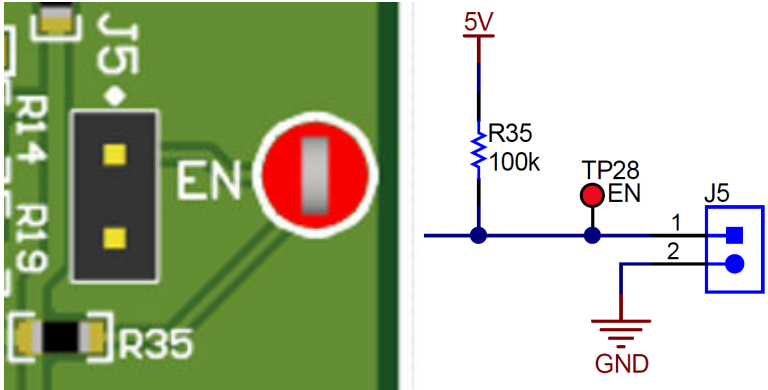
Table 3-3. TPS92519EVM Performance Specifications

Parameter	Description	Min	Typ	Max	Units
Input Characteristics					
Voltage, V_{IN}	This assumes UDIM is attached to V5D or any voltage above $V_{UDIMx(DO)}$ rising maximum of 2.52 V. The TPS92519EVM-169 has UVLO of 40-V rising and 20-V falling.	4.5	50	60	V
Maximum Input Current, I_{IN}				4.5	A
Output Characteristics					
Output Voltage, V_{OUT}	Maximum voltage configured by the output voltage divider and programmable by the SPI	V_{IN}		60	V
Maximum Output Current, I_{OUT}	Total output current per channel			2.0	A
Maximum Output Power, P_{OUT}	Total output power			120	W
Systems Characteristics					
Switching frequency	$V_{FSET} > 1.8$ V, Channel 1		384		kHz
	$V_{FSET} > 1.8$ V, Channel 2		435		
	$V_{FSET} < 0.8$ V, Channel 1		2.04		MHz
	$V_{FSET} < 0.8$ V, Channel 2		2.14		
Peak efficiency				96	%
Operating temperature	NOTE: Max temperature range is based on total power dissipation.	-40	25	125	°C

4 Test Setup

The TPS92519EVM-169 can be connected a variety of different ways. Figure 4-1 shows a typical test setup.

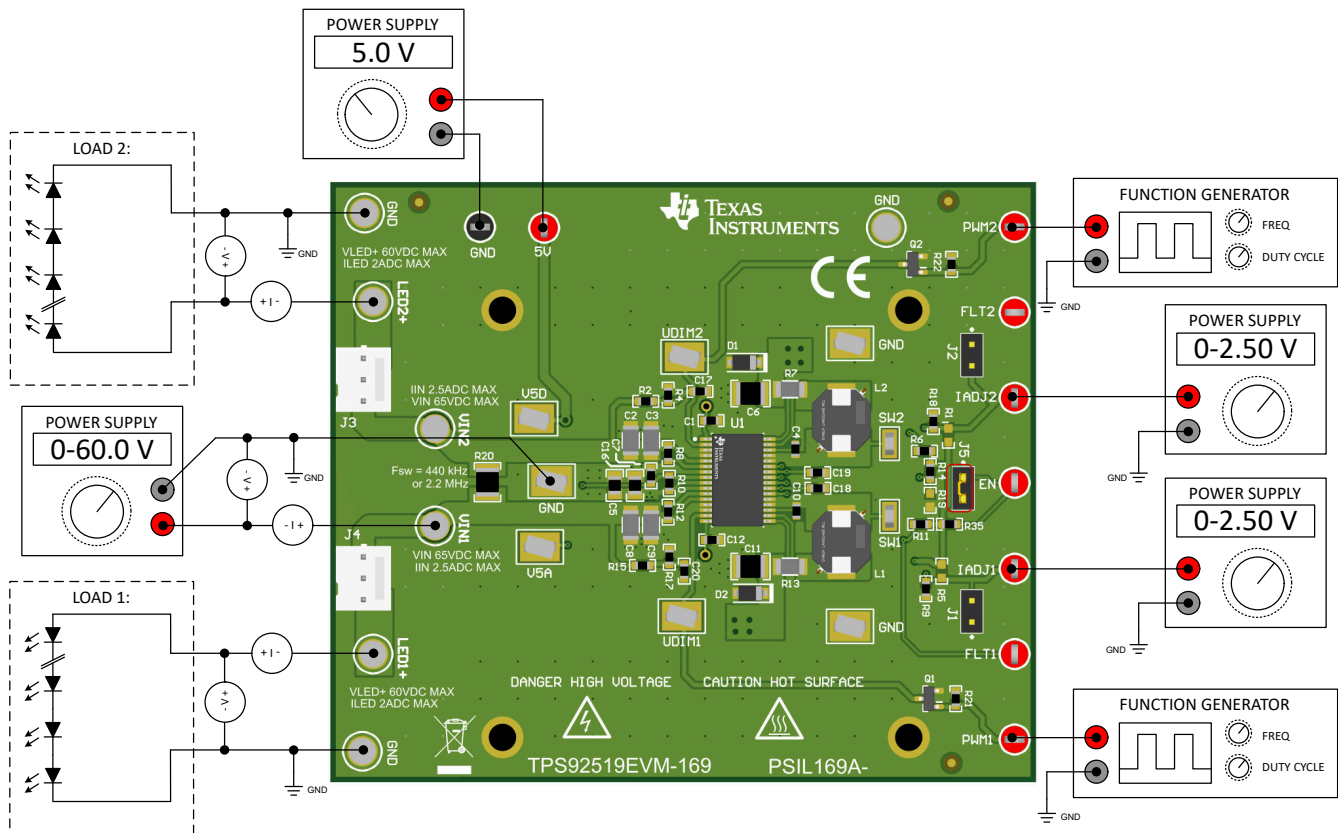

Figure 4-1. TPS92519EVM-169 Typical Test Setup

4.1 Input Supplies and LED Load Connections

The default configuration for this EVM is that both VIN1 and VIN2 are shorted together by R20. This configuration allows for a simpler connection. However, if two separate supplies are desired, then R20 must be removed and individual supplies must be connected either by the VIN1 (TP14) and VIN2 (TP6) turrets or through J3 and J4 connectors.

The LEDs are to be connected, as show in Figure 4-2, where the anode of the LEDs are to be connected to LED1+ and LED2+ test points or through J3 or J4.

V5D and V5A are tied together through R10. An external 5-V supply must be attached to the 5-V test point (TP7) to supply the TPS92519.

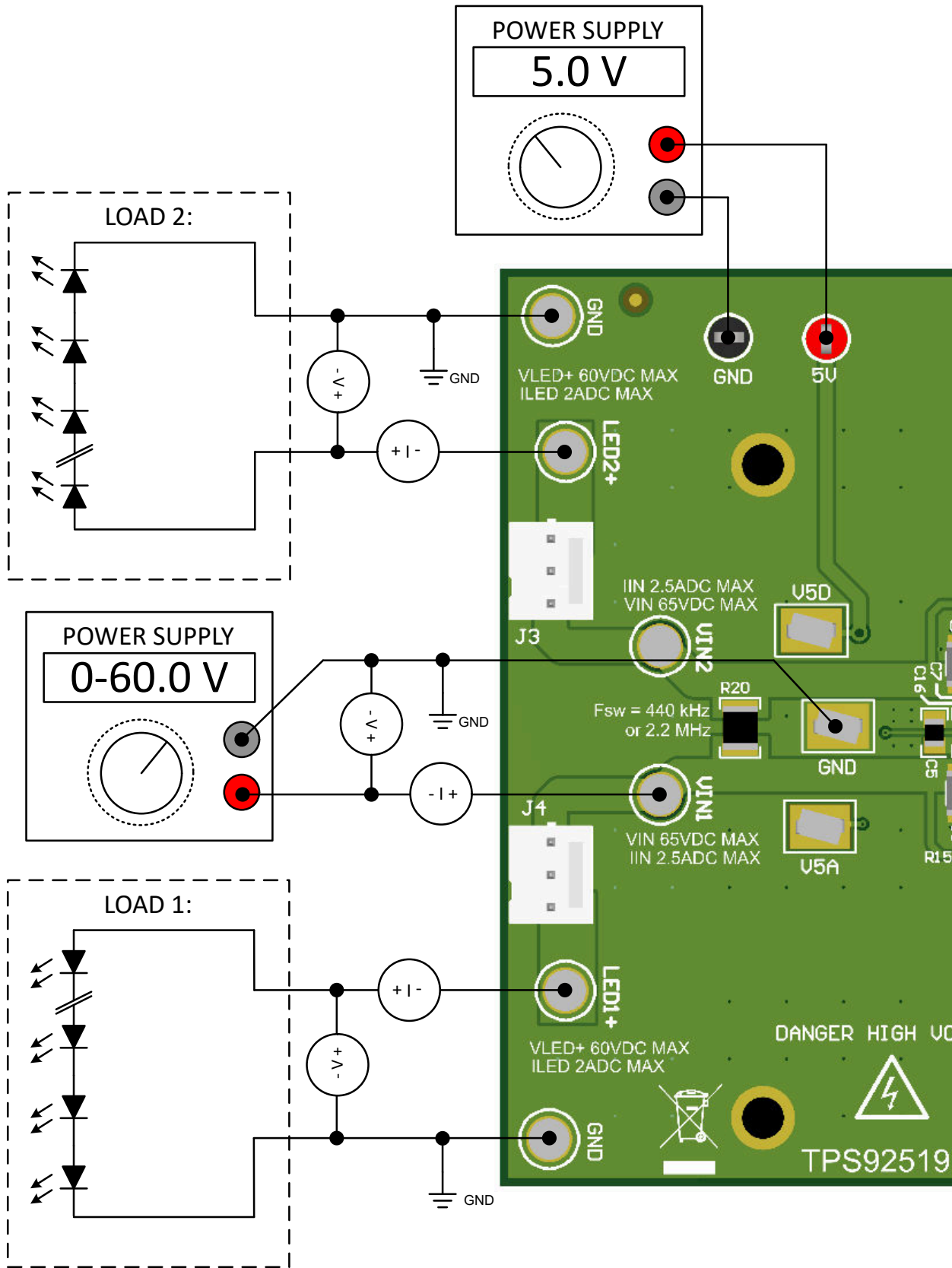

Figure 4-2. V5D, VINx and LEDx Connections

4.2 Switching Frequency Selection

The TPS92519EVM-169 is by default setup for 384 kHz for channel 1 and 438 kHz for channel 2. If 2/2.1-MHz operation is desired, then both the inductors (L1 and L2) must be changed to 10 uH and FSET must be pulled to ground by removing R14 and inserting R19.

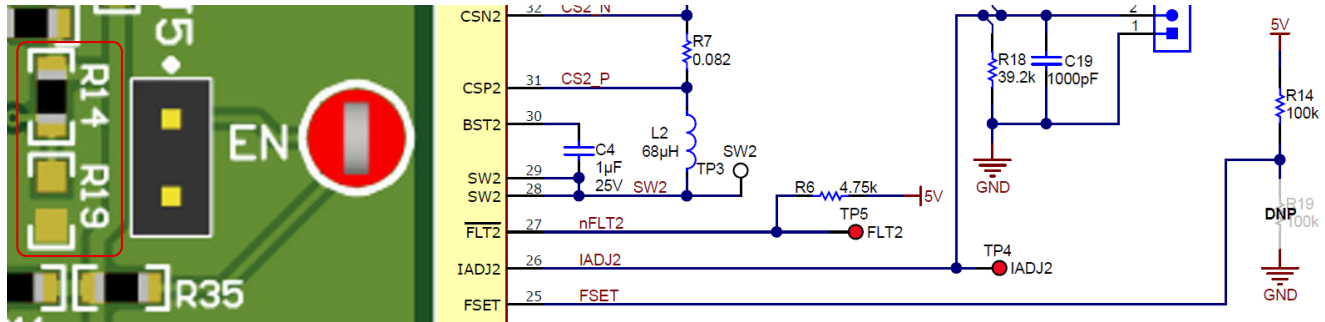

Figure 4-3. FSET Resistors and Circuit

4.3 Analog Dimming Using IADJx

Analog Dimming for each channel is controlled by IADJ1 (TP10) and IADJ2 (TP4) test points or by using the resistor divider attached to 5 V. The voltage on the IADJx pin sets the regulated LED current by the following equation.

$$I_{LEDx} = \frac{V_{IADJx}}{14 \times R_{CSx}} \tag{1}$$

By default, R_{FB2x} is not loaded and therefore needs an external power supply to set the V_{IADJx} setpoint. J1 and J2 are not loaded by default.

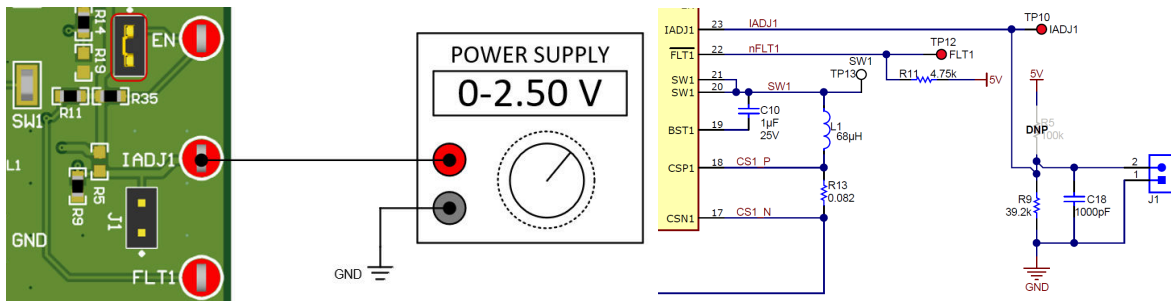

Figure 4-4. Channel 1 IADJ Using External Supply

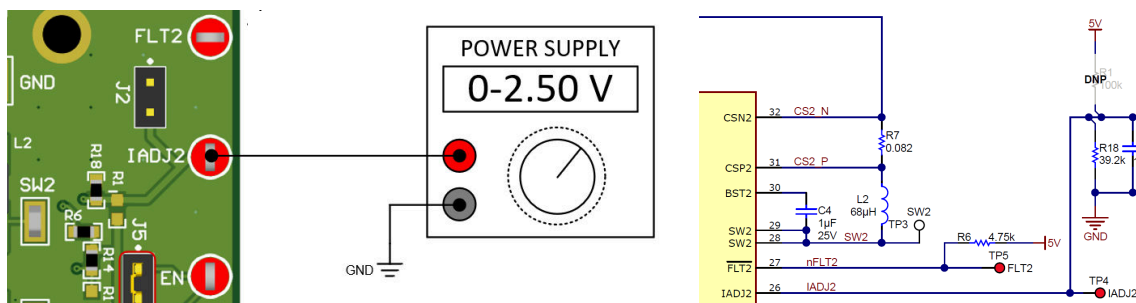

Figure 4-5. Channel 2 IADJ Using External Supply

There is a placeholder for resistor divider and R_{FB2x} has to be calculated for the desired I_{LEDx} . See Figure 4-6 for the circuit diagram and equation. R1 controls the voltage for IADJ2 and R5 controls the voltage for IADJ1. See Figure 4-7.

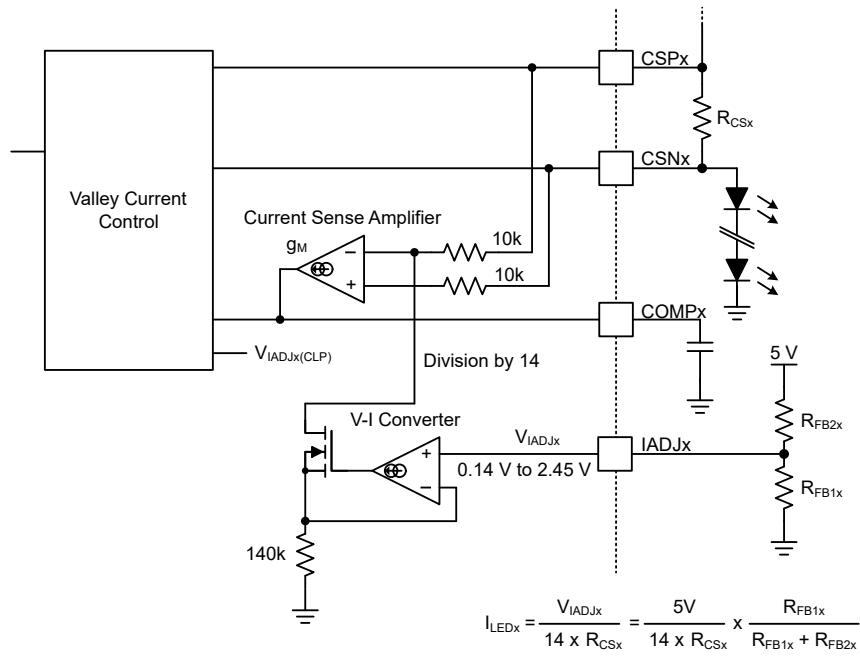

Figure 4-6. Setting IADJx Using On-Board Resistor Divider

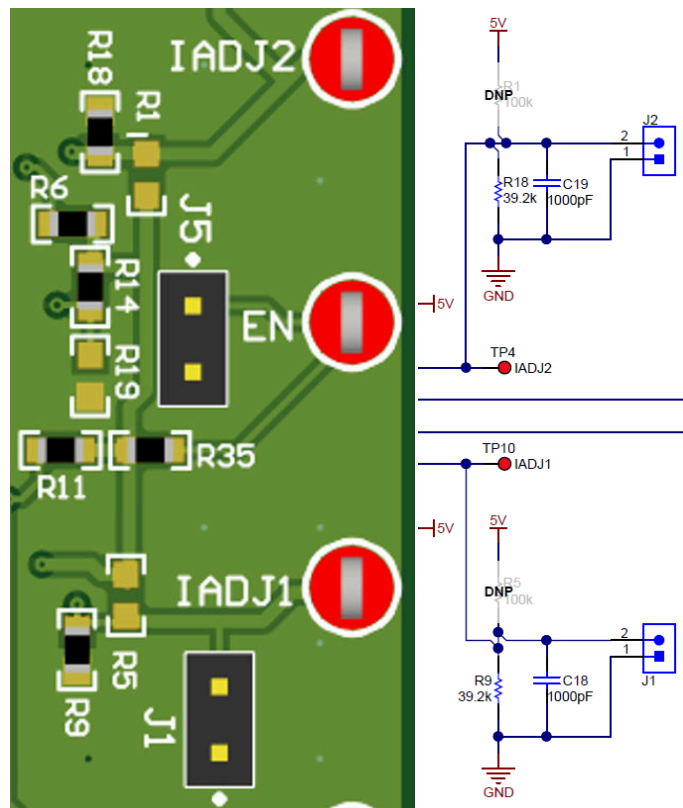

Figure 4-7. IADJ Using Resistor Divider

4.4 PWM Dimming Using UDIMx and PWM Test Points

PWM dimming can be achieved by either using the PWM1 and PWM2 test points or by the UDIM1 and UDIM2 test points. UDIM have resistor dividers that setup the UVLO from VIN (Figure 4-8). The voltage is low enough that you can connect the function generator directly. If UDIM was pulled to VIN by a resistor then the PWM test points should be used (Figure 4-9). The PWMx signal inverts the signal to UDIMx.

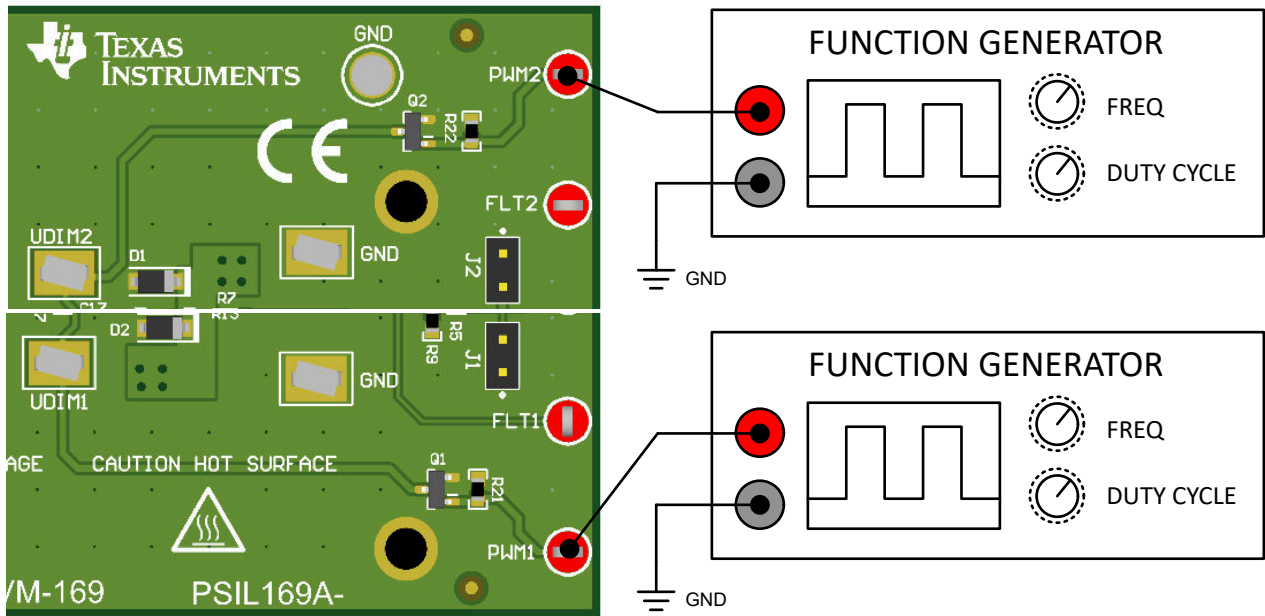

Figure 4-8. PWM Dimming Using PWM1 and PWM2

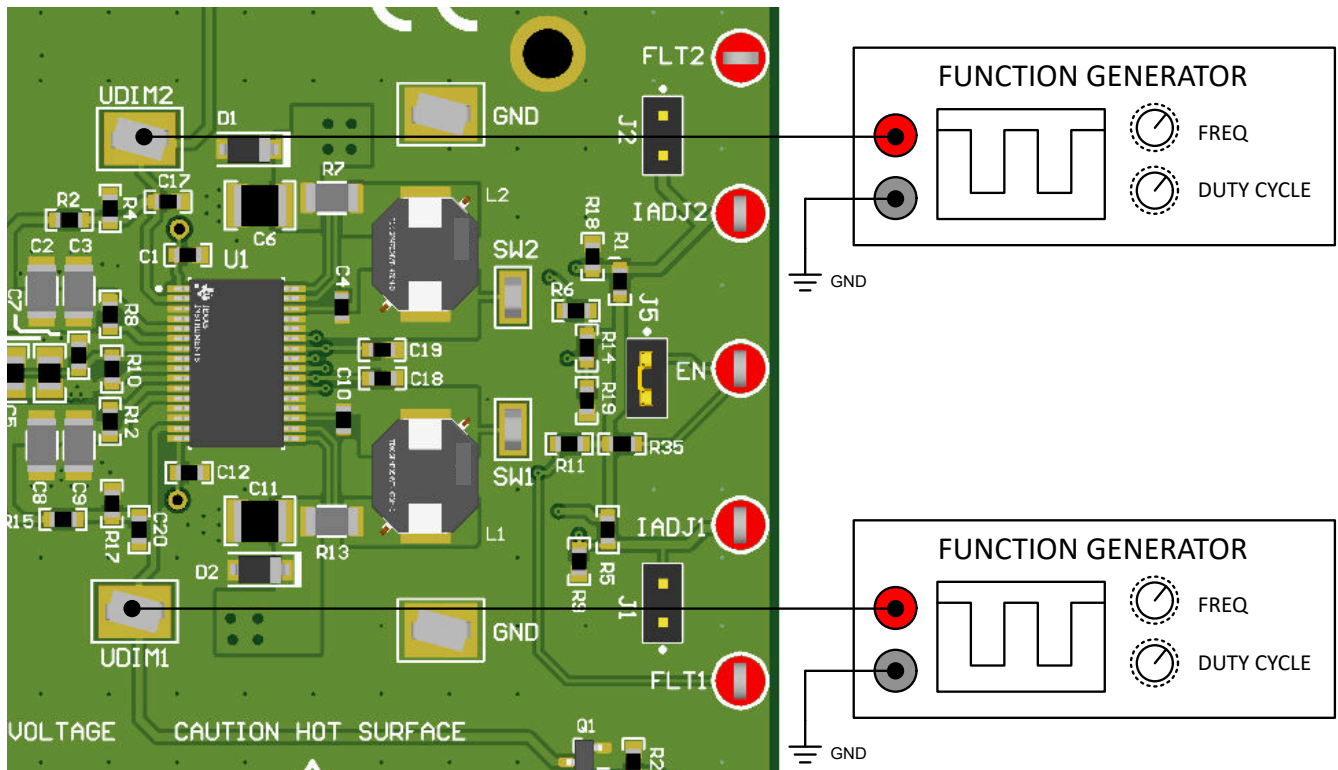

Figure 4-9. PWM Dimming Using UDIM1 and UDIM2

5 Performance Data and Typical Characteristic Curves

Figure 5-1 through Figure 5-9 present typical performance curves for TPS92519EVM-169.

5.1 Efficiency

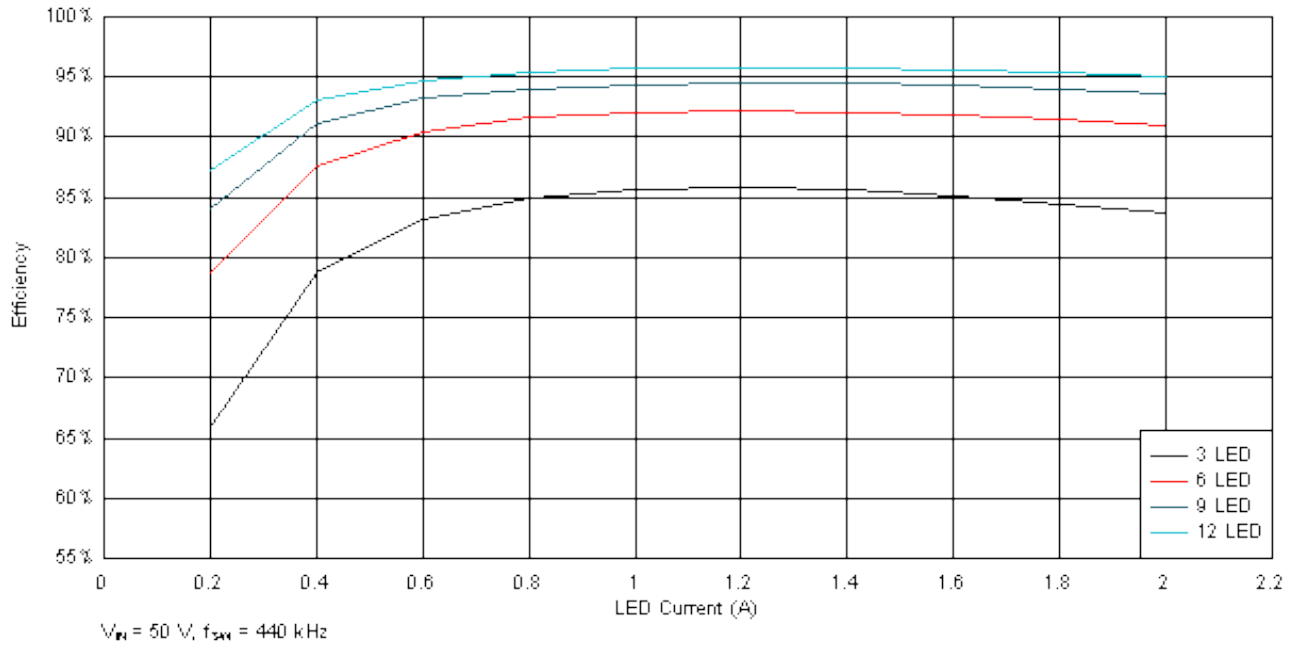

Figure 5-1. Efficiency vs. Output Current

5.2 Analog Dimming

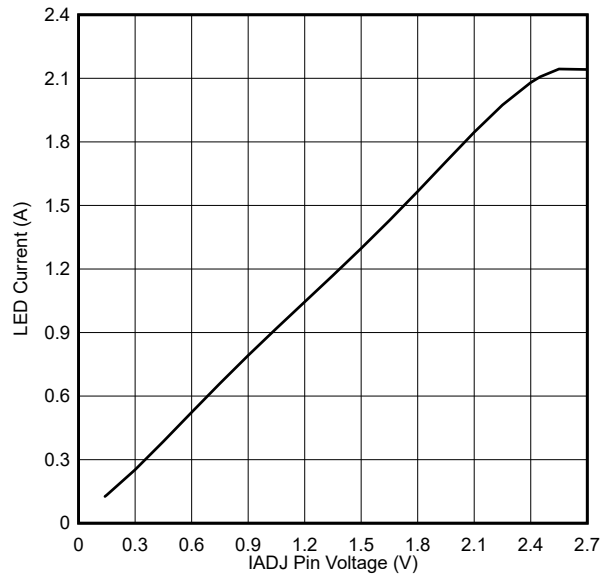

Figure 5-2. Output Current vs IADJ Voltage 48-V Input, 2 LEDs

5.3 PWM Dimming

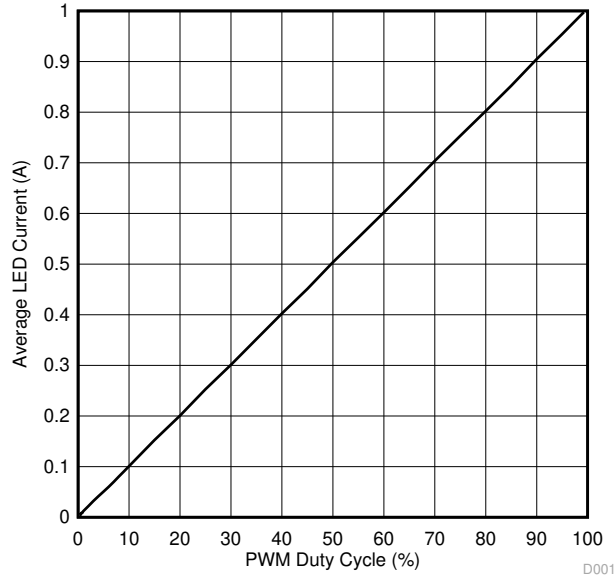

Figure 5-3. Output Current vs. PWM Duty Cycle (250 Hz) 48-V Input, 2 LEDs

5.4 PWM Dimming Waveforms

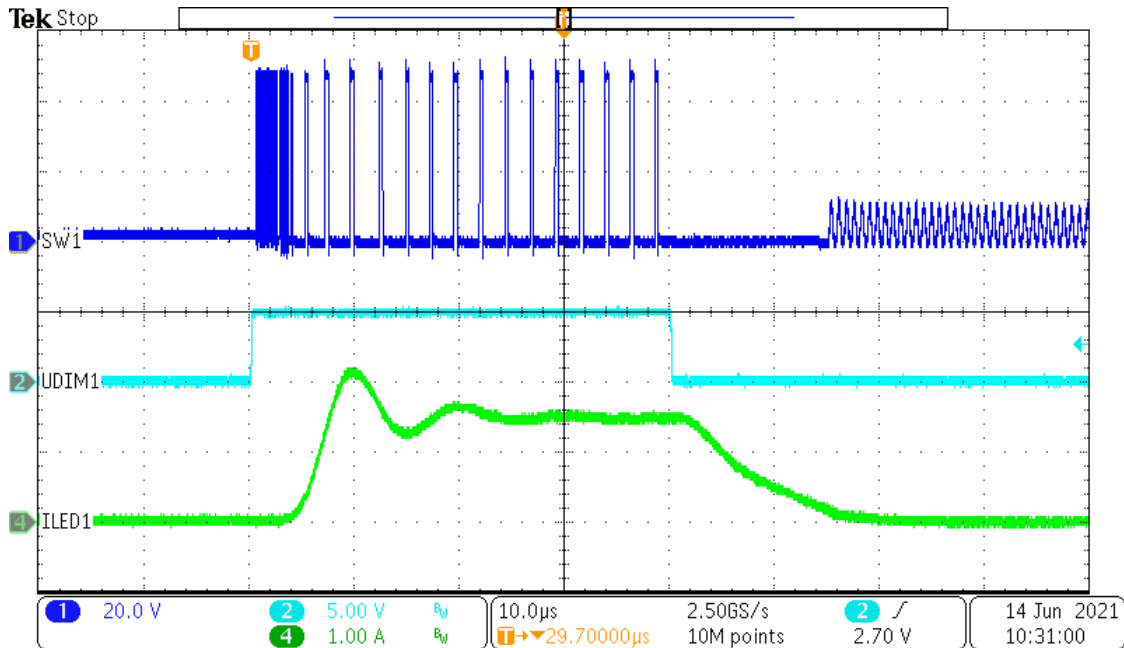

Figure 5-4. 1% Duty Cycle 250-Hz PWM Dimming Top = V_{SW} , Middle = V_{PWM} , Bottom = LED Current, Input Voltage = 48 V, 2 LEDs

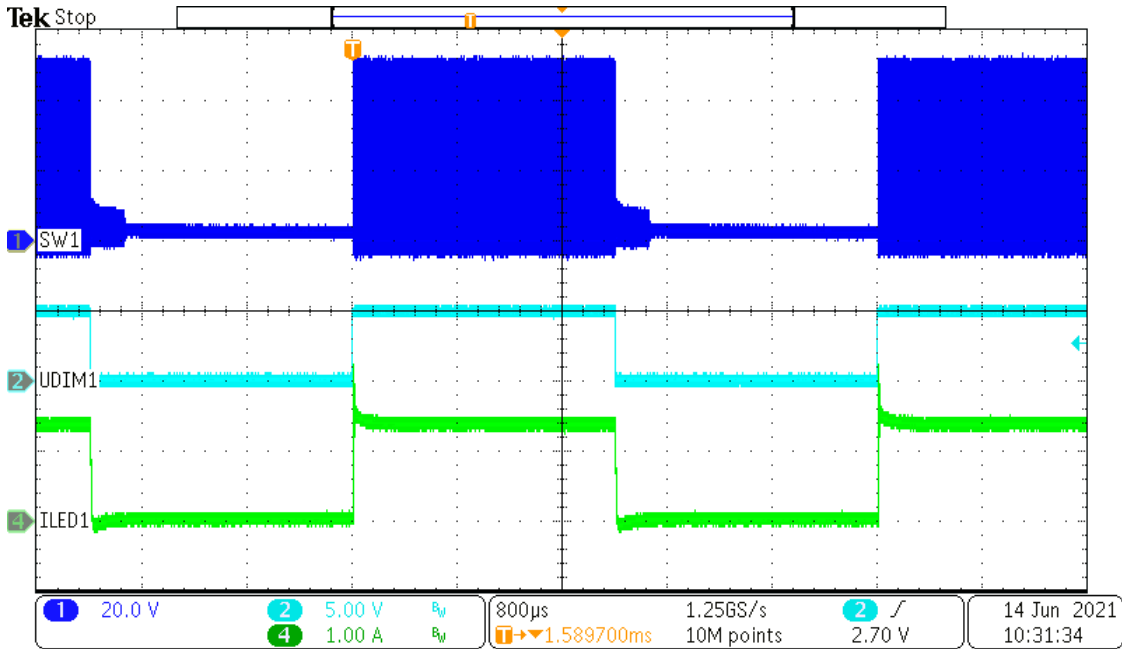

Figure 5-5. 50% Duty Cycle, 250-Hz PWM Dimming Top = V_{SW} , Middle = V_{PWM} , Bottom = LED Current, Input Voltage = 48 V, 2 LEDs

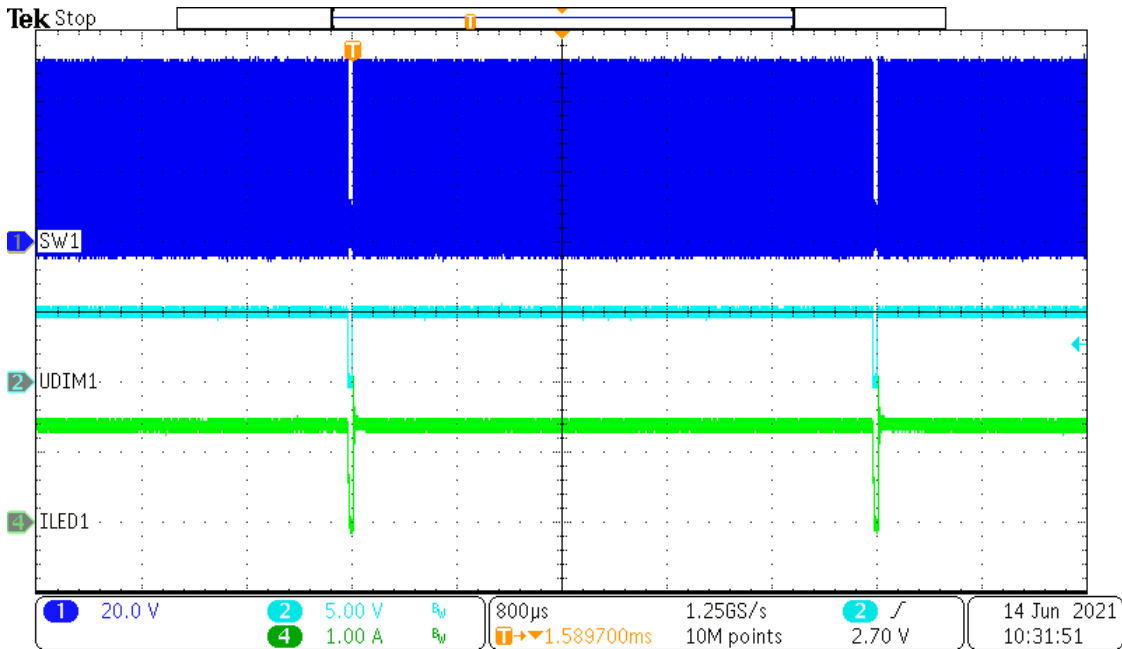

Figure 5-6. 99% Duty Cycle, 250-Hz PWM Dimming Top = V_{SW} , Middle = V_{PWM} , Bottom = LED Current, Input Voltage = 14 V, 2 LEDs

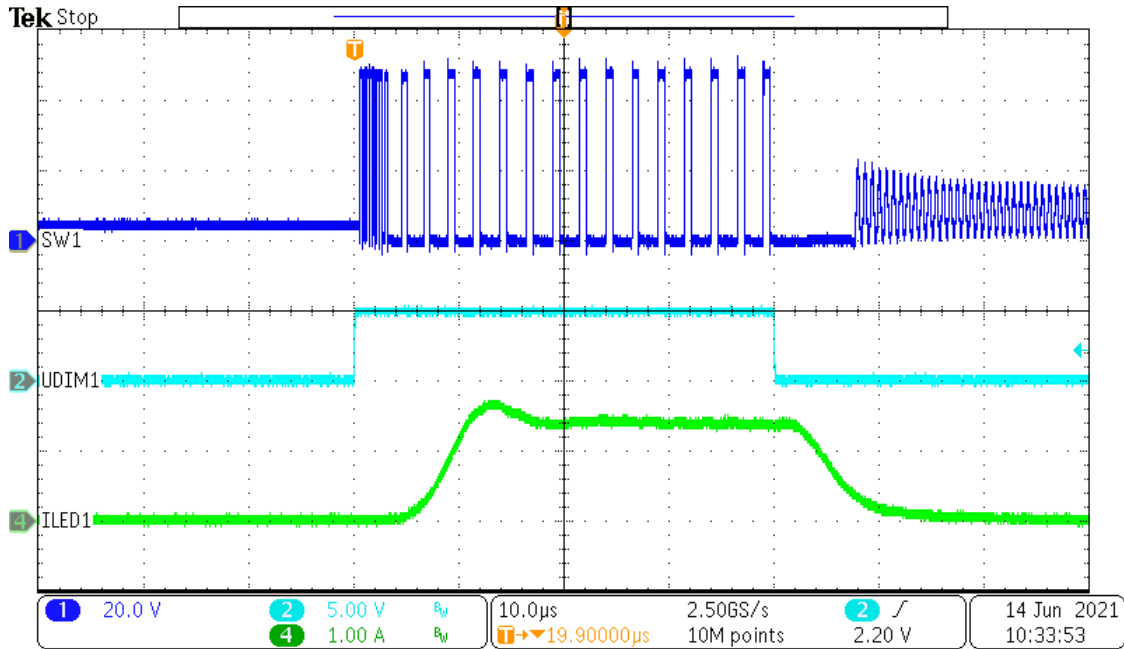

Figure 5-7. 1% Duty Cycle, 250-Hz PWM Dimming Top = V_{SW} , Middle = V_{PWM} , Bottom = LED Current, Input Voltage = 48 V, 4 LEDs

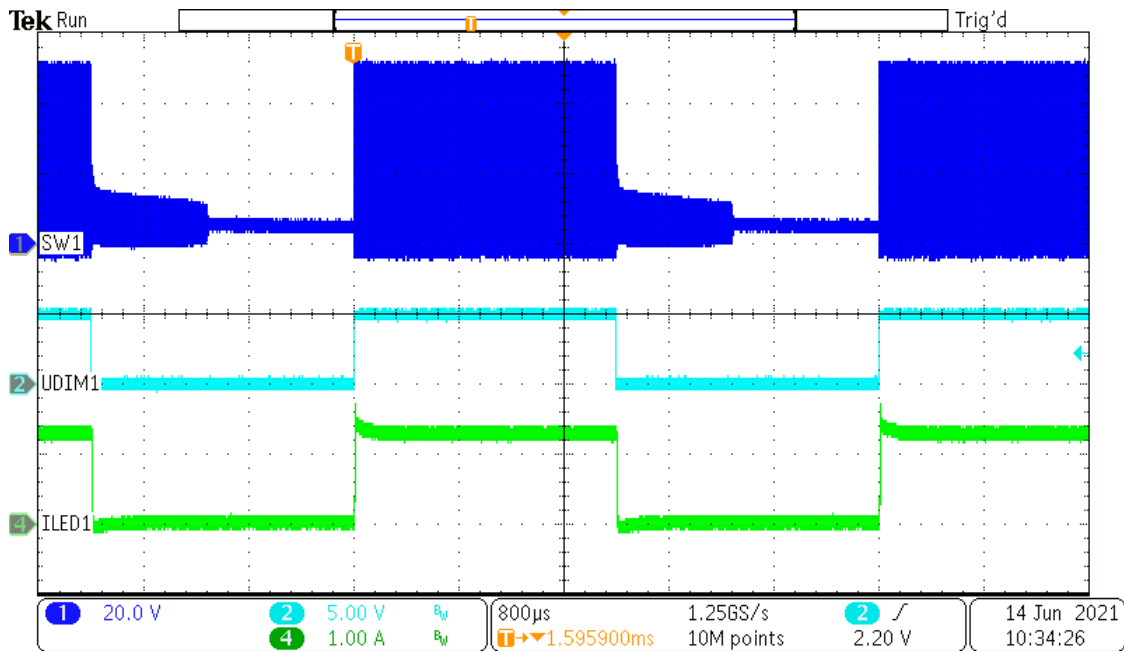

Figure 5-8. 50% Duty Cycle, 250-Hz PWM Dimming Top = V_{SW} , Middle = V_{PWM} , Bottom = LED Current, Input Voltage = 48 V, 4 LEDs

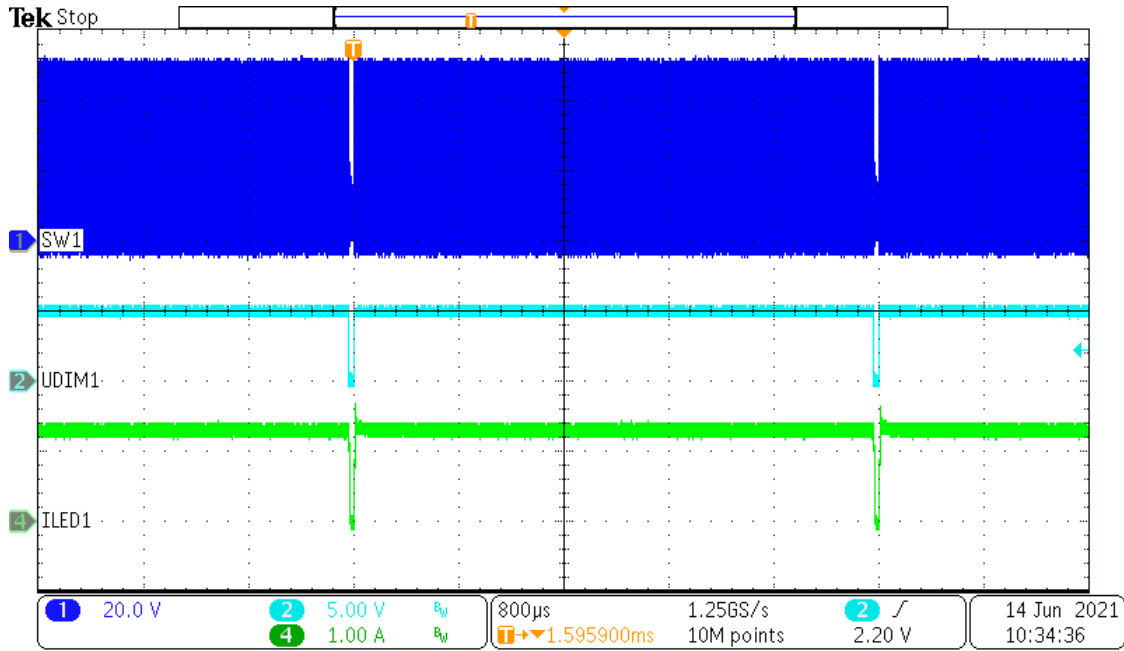

Figure 5-9. 99% Duty Cycle, 250-Hz PWM Dimming Top = V_{SW} , Middle = V_{PWM} , Bottom = LED Current, Input Voltage = 48 V, 4 LEDs

6 Schematic

Figure 6-1 illustrates the EVM schematic.

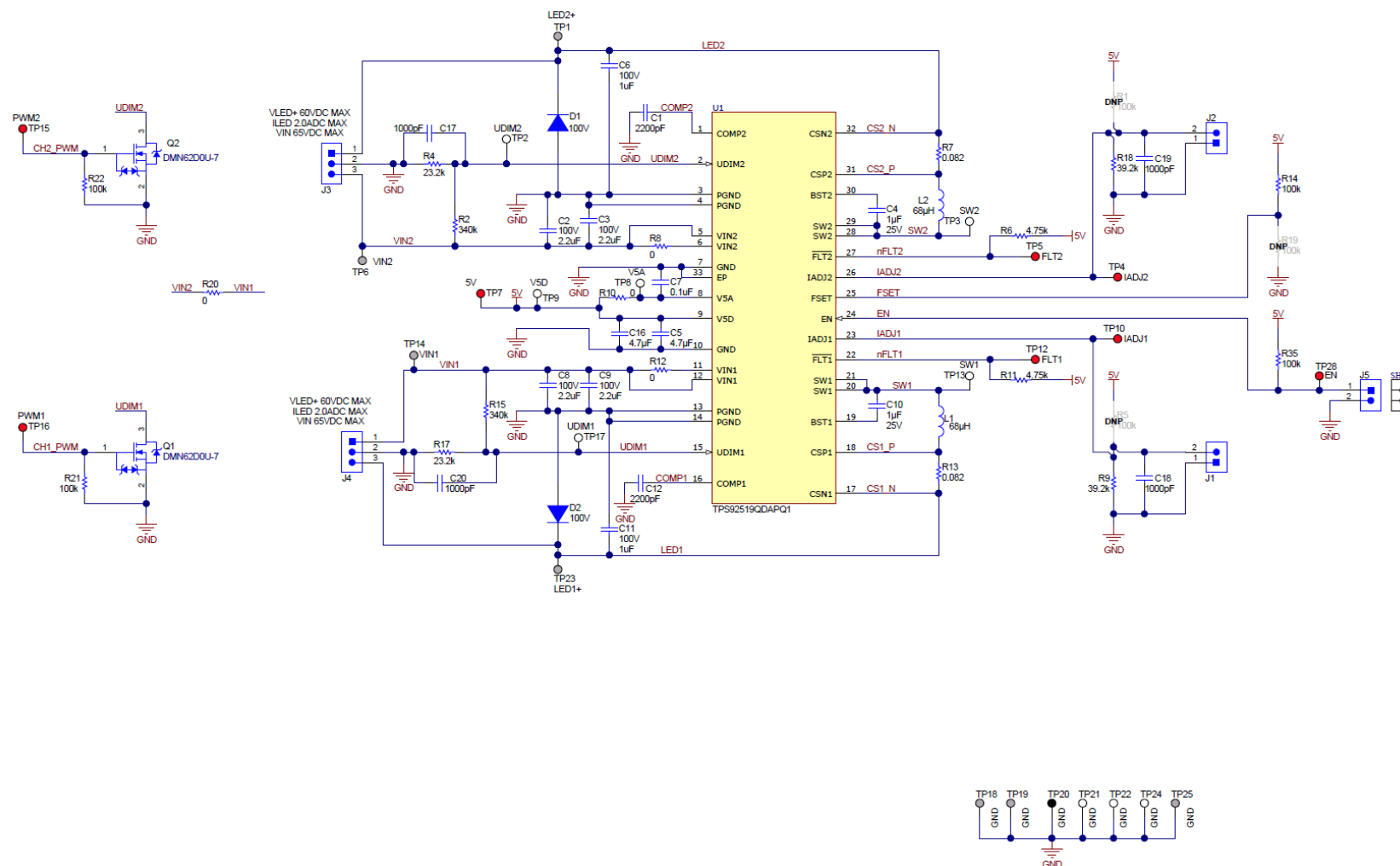
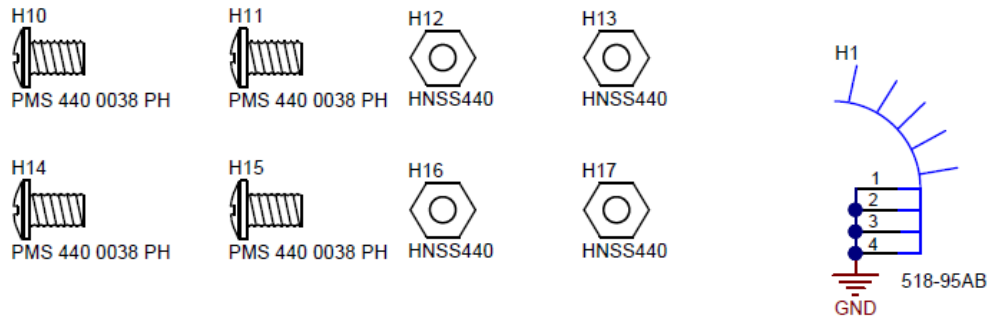

Figure 6-1. TPS92519EVM-169 Schematic Page 1



ASSEMBLY NOTE for H9:

H9-can be cut to make 20 units. Cut Sil-Pad to fit heat sink. Use dimensions shown in the PCB, can be slightly oversized. Sil-Pad fits between the PCB (bottom side) and the Heat sink. The heat sink is bolted to the PCB with H1, H2, H5, H6, H3, H4, H7, and H8. Screws are placed through the board from the top side.

H18
MECH
SPK10-0.006-AC-11.512



PCB Number: PSIL169
PCB Rev: E1

PCB LOGO
Texas Instruments



PCB LOGO
FCC disclaimer

PCB LOGO
WEEE logo



Figure 6-2. TPS92519EVM-169 Schematic Page 2

7 TPS92519EVM-169 PCB Layout

Figure 7-1, Figure 7-2, Figure 7-3, and Figure 7-4 show the design of the TPS92519EVM-169 printed circuit board.

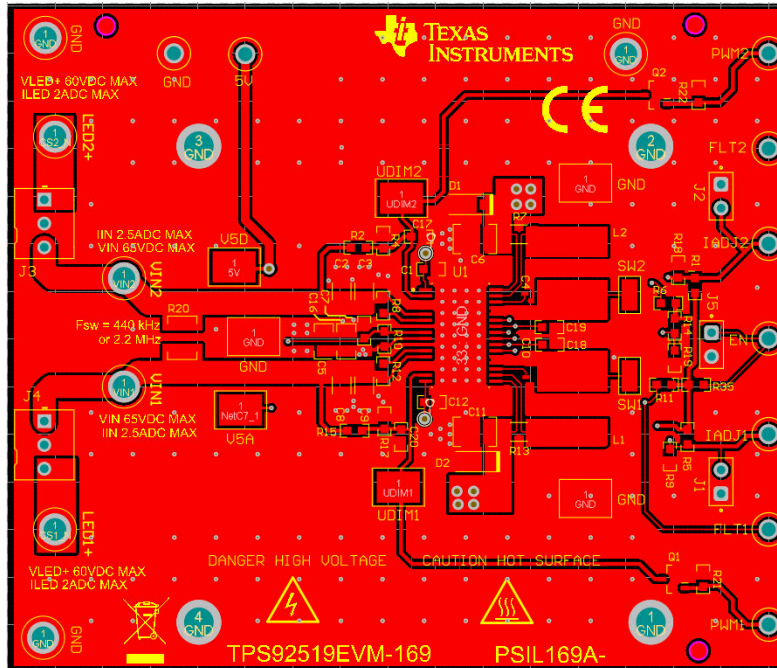

Figure 7-1. Top Layer and Top Overlay (Top View)

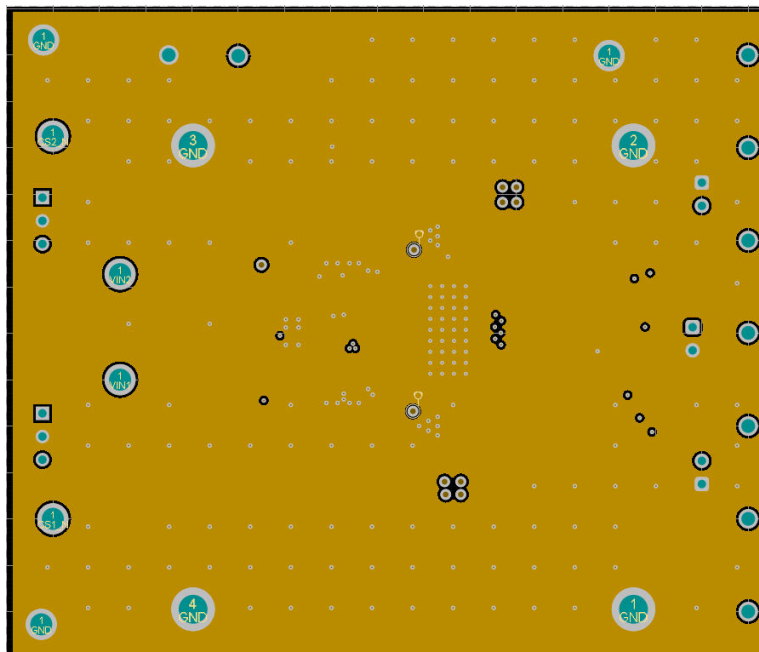

Figure 7-2. Signal Layer 1

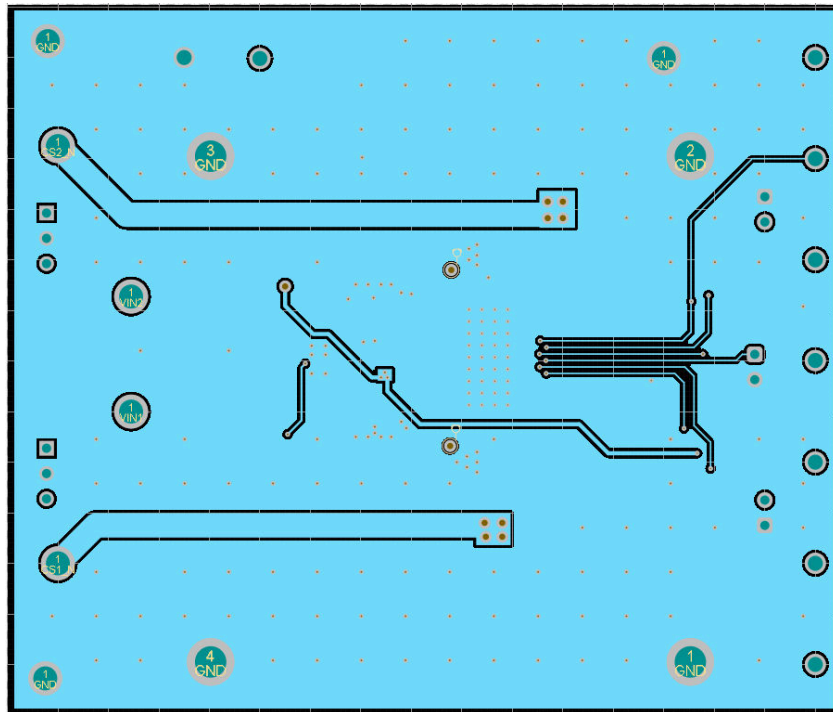

Figure 7-3. Signal Layer 2

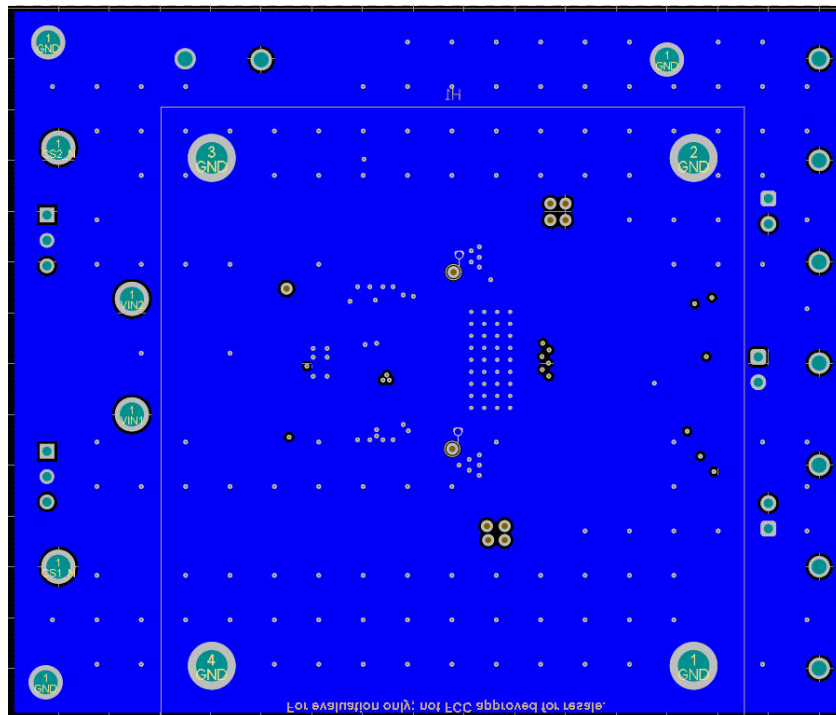

Figure 7-4. Bottom Layer and Bottom Overlay (Bottom View)

8 Bill of Materials

Table 8-1 contains the TPS92519EVM-169 components list according to the schematic shown in Figure 6-1.

Table 8-1. TPS92519EVM-169 Bill of Materials

Reference Designator	QTY	Value	Description	Size	Part Number	MFR
C1, C12	2	2200 pF	CAP, CERM, 2200 pF, 50 V, +/- 5%, C0G/NP0, 0603	0603	GRM1885C1H222JA01D	MuRata
C2, C3, C8, C9	4	2.2 uF	CAP, CERM, 2.2 uF, 100 V, +/- 20%, X7S, AEC-Q200 Grade 1, 1206_190	1206	CGA5L3X7S2A225M160AB	TDK
C4, C10	2	1 uF	CAP, CERM, 1 uF, 25 V, +/- 10%, X7R, AEC-Q200 Grade 1, 0603	0603	CGA3E1X7R1E105K080AC	TDK
C5, C16	2	4.7 uF	CAP, CERM, 4.7 uF, 16 V, +/- 10%, X7R, AEC-Q200 Grade 1, 0805	0805	CGA4J3X7R1C475K125AE	TDK
C6, C11	2	1 uF	CAP, CERM, 1 uF, 100 V, +/- 10%, X7R, AEC-Q200 Grade 1, 1210	1210	CGA6M2X7R2A105K200AA	TDK
C7	1	0.1 uF	CAP, CERM, 0.1 uF, 100 V, +/- 10%, X7S, AEC-Q200 Grade 1, 0603	0603	CGA3E3X7S2A104K080AB	TDK
C17, C18, C19, C20	4	1000 pF	CAP, CERM, 1000 pF, 50 V, +/- 10%, C0G/NP0, 0603	0603	06035A102KAT2A	AVX
D1, D2	2	100 V	Diode, Switching, 100 V, 0.25 A, AEC-Q101, SOD-123	SOD-123	BAS16D-E3-08	Vishay-Semiconductor
D3, D4	2	80V	Diode, Schottky, 80 V, 0.5 A, SOD-123	SOD-123	MBR0580-TP	Micro Commercial Components
H1	1		HEATSINK DC/DC HALF BRICK VERT	DC/DC Half Brick Vertical Heat Sink	528-45AB	Wakefield Solutions
H10, H11, H14, H15	4		MACHINE SCREW PAN PHILLIPS 4-40		PMS 440 0038 PH	B&F Fastener Supply
H12, H13, H16, H17	4		Stainless steel 4-40 nut		HNSS440	B&F Fastener Supply
H18	1		Thermal Pad-this part number is enough material make 20 units		SPK10-0.006-AC-11.512	BERGQUIST
J1, J2, J5	3		Header, 100mil, 2x1, Gold, TH	2x1 Header	TSW-102-07-G-S	Samtec
J3, J4	2		Header, 2.54 mm, 3x1, Tin, TH	Header, 2.54mm, 3x1, TH	22-23-2031	Molex
L1, L2	2		SMD Power Inductor	STM_7MM5_7MM0	SPM7054VT- 680M-D	TDK
Q1, Q2	2	60 V	MOSFET, N-CH, 60 V, 0.38 A, AEC-Q101, SOT-23	SOT-23	DMN62D0U-7	Diodes Inc.
R2, R15	2	576 k	RES, 576 k, 1%, 0.1 W, AEC-Q200 Grade 0, 0603	0603	CRCW0603576KFKEA	Vishay-Dale
R4, R17	2	23.2 k	RES, 23.2 k, 1%, 0.1 W, AEC-Q200 Grade 0, 0603	0603	CRCW0603232KFKEA	Vishay-Dale
R6, R11	2	4.75 k	RES, 4.75 k, 1%, 0.1 W, AEC-Q200 Grade 0, 0603	0603	CRCW06034K75FKEA	Vishay-Dale
R7, R13	2	0.082	RES, 0.082, 1%, .75 W, AEC-Q200 Grade 0, 1206	1206	KRL1632E-M-R082-F-T5	Susumu Co Ltd
R8, R10, R12	3	0	RES, 0, 5%, 0.1 W, AEC-Q200 Grade 0, 0603	0603	CRCW06030000Z0EA	Vishay-Dale
R9, R18	2	39.2 k	RES, 39.2 k, 1%, 0.1 W, AEC-Q200 Grade 0, 0603	0603	CRCW060339K2FKEA	Vishay-Dale

Table 8-1. TPS92519EVM-169 Bill of Materials (continued)

Reference Designator	QTY	Value	Description	Size	Part Number	MFR
R14, R21, R22, R35	4	100 k	RES, 100 k, 1%, 0.1 W, AEC-Q200 Grade 0, 0603	0603	CRCW0603100KFKEA	Vishay-Dale
R20	1	0	RES, 0, 1%, 0.5 W, AEC-Q200 Grade 0, 1210	1210	CRCW12100000Z0EA	Vishay-Dale
SH-J1, SH-J2	2		Shunt, 100mil, Gold plated, Black		SNT-100-BK-G	Samtec
TP1, TP6, TP14, TP18, TP19, TP23	6		Terminal, Turret, TH, Double	Keystone1502-2	1502-2	Keystone
TP2, TP3, TP8, TP9, TP13, TP17	6		Test Point, Miniature, SMT	Testpoint_Keystone_Minimature	5015	Keystone
TP4, TP5, TP10, TP12, TP15, TP16, TP28	7		Test Point, Multipurpose, Red, TH	Multipurpose Testpoint	5010	Keystone
TP11, TP20	2		Test Point, Multipurpose, Black, TH	Black Multipurpose Testpoint	5011	Keystone
TP21, TP22, TP24	3		Test Point, Compact, SMT	Testpoint_Keystone_Compact	5016	Keystone
U1	1		4.5-V to 65-V Dual 2-A Synchronous Buck LED Driver	TSSOP32	TPS92519QDAPQ1	Texas Instruments
U4	0		Automotive 60V, 5-uA Iq, 100-mA, Low-Dropout Voltage Regulator with Enable and Power Good, DGN0008B (VSSOP-8)	DGN0008B	TPS7A1601AQDGNRQ1	Texas Instruments
R1, R5, R19	0	100 k	RES, 100 k, 1%, 0.1 W, AEC-Q200 Grade 0, 0603	0603	CRCW0603100KFKEA	Vishay-Dale
R3	0	3.4 Meg	RES, 3.40 M, 1%, 0.1 W, AEC-Q200 Grade 0, 0603	0603	CRCW06033M40FKEA	Vishay-Dale
R16	0	4.75 k	RES, 4.75 k, 1%, 0.1 W, AEC-Q200 Grade 0, 0603	0603	CRCW06034K75FKEA	Vishay-Dale
R23	0	1.07 Meg	RES, 1.07 M, 1%, 0.1 W, AEC-Q200 Grade 0, 0603	0603	CRCW06031M07FKEA	Vishay-Dale
C21	0	4.7 uF	CAP, CERM, 4.7 uF, 16 V, +/- 10%, X7R, AEC-Q200 Grade 1, 0805	0805	CGA4J3X7R1C475K125AE	TDK
C22	0	2.2 uF	CAP, CERM, 2.2 uF, 100 V, +/- 20%, X7S, AEC-Q200 Grade 1, 1206_190	1206	CGA5L3X7S2A225M160AB	TDK
C23	0	0.1 uF	CAP, CERM, 0.1 uF, 50 V, +/- 20%, X7R, AEC-Q200 Grade 1, 0402	0402	CGA2B3X7R1H104M050BB	TDK
J6	0		Header, 100mil, 2x1, Gold, TH	2x1 Header	TSW-102-07-G-S	Samtec
TP7	0		Test Point, Multipurpose, Red, TH	Multipurpose Testpoint	5010	Keystone

9 Revision History

NOTE: Page numbers for previous revisions may differ from page numbers in the current version.

Changes from Revision * (July 2021) to Revision A (November 2021) Page

- Updated the tables, figures, and references to the TPS92519EVM-169 board, which changed from Rev E1 to Rev A..... 1

IMPORTANT NOTICE AND DISCLAIMER

TI PROVIDES TECHNICAL AND RELIABILITY DATA (INCLUDING DATA SHEETS), DESIGN RESOURCES (INCLUDING REFERENCE DESIGNS), APPLICATION OR OTHER DESIGN ADVICE, WEB TOOLS, SAFETY INFORMATION, AND OTHER RESOURCES "AS IS" AND WITH ALL FAULTS, AND DISCLAIMS ALL WARRANTIES, EXPRESS AND IMPLIED, INCLUDING WITHOUT LIMITATION ANY IMPLIED WARRANTIES OF MERCHANTABILITY, FITNESS FOR A PARTICULAR PURPOSE OR NON-INFRINGEMENT OF THIRD PARTY INTELLECTUAL PROPERTY RIGHTS.

These resources are intended for skilled developers designing with TI products. You are solely responsible for (1) selecting the appropriate TI products for your application, (2) designing, validating and testing your application, and (3) ensuring your application meets applicable standards, and any other safety, security, regulatory or other requirements.

These resources are subject to change without notice. TI grants you permission to use these resources only for development of an application that uses the TI products described in the resource. Other reproduction and display of these resources is prohibited. No license is granted to any other TI intellectual property right or to any third party intellectual property right. TI disclaims responsibility for, and you will fully indemnify TI and its representatives against, any claims, damages, costs, losses, and liabilities arising out of your use of these resources.

TI's products are provided subject to [TI's Terms of Sale](#) or other applicable terms available either on ti.com or provided in conjunction with such TI products. TI's provision of these resources does not expand or otherwise alter TI's applicable warranties or warranty disclaimers for TI products.

TI objects to and rejects any additional or different terms you may have proposed.

Mailing Address: Texas Instruments, Post Office Box 655303, Dallas, Texas 75265
Copyright © 2022, Texas Instruments Incorporated