

TMS320C674x/OMAP-L1x Processor Enhanced Quadrature Encoder Pulse (eQEP) Module

User's Guide



Literature Number: SPRUFL4A
April 2009

| | |
|---|-----------|
| Preface | 6 |
| 1 Introduction | 8 |
| 2 Architecture | 11 |
| 2.1 EQEP Inputs | 11 |
| 2.2 Functional Description | 11 |
| 2.3 Quadrature Decoder Unit (QDU) | 13 |
| 2.4 Position Counter and Control Unit (PCCU) | 16 |
| 2.5 eQEP Edge Capture Unit..... | 23 |
| 2.6 eQEP Watchdog | 26 |
| 2.7 Unit Timer Base..... | 27 |
| 2.8 eQEP Interrupt Structure | 27 |
| 3 Registers | 28 |
| 3.1 eQEP Position Counter Register (QPOSCNT) | 29 |
| 3.2 eQEP Position Counter Initialization Register (QPOSINIT)..... | 29 |
| 3.3 eQEP Maximum Position Count Register (QPOSMAX)..... | 29 |
| 3.4 eQEP Position-Compare Register (QPOSCMP) | 30 |
| 3.5 eQEP Index Position Latch Register (QPOSILAT)..... | 30 |
| 3.6 eQEP Strobe Position Latch Register (QPOSSLAT) | 30 |
| 3.7 eQEP Position Counter Latch Register (QPOSLAT) | 31 |
| 3.8 eQEP Unit Timer Register (QUTMR) | 31 |
| 3.9 eQEP Unit Period Register (QUPRD) | 31 |
| 3.10 eQEP Watchdog Timer Register (QWDTMR) | 32 |
| 3.11 eQEP Watchdog Period Register (QWDPRD)..... | 32 |
| 3.12 QEP Decoder Control Register (QDECCTL)..... | 33 |
| 3.13 eQEP Control Register (QEPCTL) | 34 |
| 3.14 eQEP Capture Control Register (QCAPCTL)..... | 36 |
| 3.15 eQEP Position-Compare Control Register (QPOSCTL)..... | 37 |
| 3.16 eQEP Interrupt Enable Register (QEINT) | 38 |
| 3.17 eQEP Interrupt Flag Register (QFLG) | 39 |
| 3.18 eQEP Interrupt Clear Register (QCLR)..... | 40 |
| 3.19 eQEP Interrupt Force Register (QFRC) | 41 |
| 3.20 eQEP Status Register (QEPSTS) | 43 |
| 3.21 eQEP Capture Timer Register (QCTMR) | 44 |
| 3.22 eQEP Capture Period Register (QCPRD)..... | 44 |
| 3.23 eQEP Capture Timer Latch Register (QCTMRLAT) | 44 |
| 3.24 eQEP Capture Period Latch Register (QCPRDLAT) | 45 |
| 3.25 eQEP Revision ID Register (REVID)..... | 45 |
| Appendix A Revision History | 46 |

List of Figures

| | | |
|----|---|----|
| 1 | Optical Encoder Disk | 8 |
| 2 | QEP Encoder Output Signal for Forward/Reverse Movement..... | 9 |
| 3 | Index Pulse Example | 9 |
| 4 | Functional Block Diagram of the eQEP Peripheral | 12 |
| 5 | Functional Block Diagram of Decoder Unit | 13 |
| 6 | Quadrature Decoder State Machine | 15 |
| 7 | Quadrature-clock and Direction Decoding | 15 |
| 8 | Position Counter Reset by Index Pulse for 1000 Line Encoder (QPOS MAX = 3999 or F9Fh) | 17 |
| 9 | Position Counter Underflow/Overflow (QPOS MAX = 4) | 18 |
| 10 | Software Index Marker for 1000-line Encoder (QEPCTL[I EL] = 1) | 20 |
| 11 | Strobe Event Latch (QEPCTL[SEL] = 1) | 20 |
| 12 | eQEP Position-compare Unit | 21 |
| 13 | eQEP Position-compare Event Generation Points..... | 22 |
| 14 | eQEP Position-compare Sync Output Pulse Stretcher | 22 |
| 15 | eQEP Edge Capture Unit | 24 |
| 16 | Unit Position Event for Low Speed Measurement (QCAPCTL[U PPS] = 0010) | 24 |
| 17 | eQEP Edge Capture Unit - Timing Details | 25 |
| 18 | eQEP Watchdog Timer | 26 |
| 19 | eQEP Unit Time Base | 27 |
| 20 | eQEP Interrupt Generation | 27 |
| 21 | eQEP Position Counter Register (QPOSCNT) | 29 |
| 22 | eQEP Position Counter Initialization Register (QPOSINIT)..... | 29 |
| 23 | eQEP Maximum Position Count Register (QPOS MAX)..... | 29 |
| 24 | eQEP Position-Compare Register (QPOSCMP) | 30 |
| 25 | eQEP Index Position Latch Register (QPOSILAT) | 30 |
| 26 | eQEP Strobe Position Latch Register (QPOSSLAT) | 30 |
| 27 | eQEP Position Counter Latch Register (QPOSLAT) | 31 |
| 28 | eQEP Unit Timer Register (QUTMR) | 31 |
| 29 | eQEP Unit Period Register (QUPRD) | 31 |
| 30 | eQEP Watchdog Timer Register (QWDTMR) | 32 |
| 31 | eQEP Watchdog Period Register (QWDPRD) | 32 |
| 32 | QEP Decoder Control Register (QDECCTL) | 33 |
| 33 | eQEP Control Register (QEPCTL) | 34 |
| 34 | eQEP Capture Control Register (QCAPCTL) | 36 |
| 35 | eQEP Position-Compare Control Register (QPOSCTL) | 37 |
| 36 | eQEP Interrupt Enable Register (QEINT)..... | 38 |
| 37 | eQEP Interrupt Flag Register (QFLG)..... | 39 |
| 38 | eQEP Interrupt Clear Register (QCLR)..... | 40 |
| 39 | eQEP Interrupt Force Register (QFRC)..... | 41 |
| 40 | eQEP Status Register (QEPSTS)..... | 43 |
| 41 | eQEP Capture Timer Register (QCTMR) | 44 |
| 42 | eQEP Capture Period Register (QCP RD) | 44 |
| 43 | eQEP Capture Timer Latch Register (QCTMRLAT)..... | 44 |
| 44 | eQEP Capture Period Latch Register (QCP RD LAT) | 45 |
| 45 | eQEP Revision ID Register (REVID) | 45 |

List of Tables

| | | |
|-----|---|----|
| 1 | Quadrature Decoder Truth Table | 14 |
| 2 | EQEP Registers | 28 |
| 3 | eQEP Position Counter Register (QPOSCNT) Field Descriptions..... | 29 |
| 4 | eQEP Position Counter Initialization Register (QPOSINIT) Field Descriptions | 29 |
| 5 | eQEP Maximum Position Count Register (QPOSMAX) Field Descriptions | 29 |
| 6 | eQEP Position-Compare Register (QPOSCMP) Field Descriptions..... | 30 |
| 7 | eQEP Index Position Latch Register (QPOSILAT) Field Descriptions | 30 |
| 8 | eQEP Strobe Position Latch Register (QPOSSLAT) Field Descriptions..... | 30 |
| 9 | eQEP Position Counter Latch Register (QPOSLAT) Field Descriptions..... | 31 |
| 10 | eQEP Unit Timer Register (QUTMR) Field Descriptions..... | 31 |
| 11 | eQEP Unit Period Register (QUPRD) Field Descriptions..... | 31 |
| 12 | eQEP Watchdog Timer Register (QWDTMR) Field Descriptions..... | 32 |
| 13 | eQEP Watchdog Period Register (QWDPRD) Field Description | 32 |
| 14 | eQEP Decoder Control Register (QDECCTL) Field Descriptions | 33 |
| 15 | eQEP Control Register (QEPCTL) Field Descriptions..... | 34 |
| 16 | eQEP Capture Control Register (QCAPCTL) Field Descriptions | 36 |
| 17 | eQEP Position-Compare Control Register (QPOSCTL) Field Descriptions | 37 |
| 18 | eQEP Interrupt Enable Register (QEINT) Field Descriptions | 38 |
| 19 | eQEP Interrupt Flag Register (QFLG) Field Descriptions..... | 39 |
| 20 | eQEP Interrupt Clear Register (QCLR) Field Descriptions | 40 |
| 21 | eQEP Interrupt Force Register (QFRC) Field Descriptions..... | 42 |
| 22 | eQEP Status Register (QEPSTS) Field Descriptions | 43 |
| 23 | eQEP Capture Time Register (QCTMR) Field Descriptions..... | 44 |
| 24 | eQEP Capture Period Register (QCPRD) Field Descriptions | 44 |
| 25 | eQEP Capture Timer Latch Register (QCTMRLAT) Field Descriptions | 44 |
| 26 | eQEP Capture Period Latch Register (QCPRDLAT) Field Descriptions..... | 45 |
| 27 | eQEP Revision ID Register (REVID) Field Descriptions | 45 |
| A-1 | Document Revision History | 46 |

Read This First

About This Manual

This document describes the enhanced quadrature encoder pulse (eQEP) module. The eQEP module is used for direct interface with a linear or rotary incremental encoder to get position, direction, and speed information from a rotating machine for use in a high-performance motion and position-control system.

Notational Conventions

This document uses the following conventions.

- Hexadecimal numbers are shown with the suffix h. For example, the following number is 40 hexadecimal (decimal 64): 40h.
- Registers in this document are shown in figures and described in tables.
 - Each register figure shows a rectangle divided into fields that represent the fields of the register. Each field is labeled with its bit name, its beginning and ending bit numbers above, and its read/write properties below. A legend explains the notation used for the properties.
 - Reserved bits in a register figure designate a bit that is used for future device expansion.

Related Documentation From Texas Instruments

The following documents describe the TMS320C674x Digital Signal Processors (DSPs) and OMAP-L1x Applications Processors. Copies of these documents are available on the Internet at www.ti.com. *Tip:* Enter the literature number in the search box provided at www.ti.com.

The current documentation that describes the DSP, related peripherals, and other technical collateral, is available in the C6000 DSP product folder at: www.ti.com/c6000.

[SPRUGJ0](#) — ***TMS320C6743 DSP System Reference Guide***. Describes the System-on-Chip (SoC) including the C6743 DSP subsystem, system memory, device clocking, phase-locked loop controller (PLL), power and sleep controller (PSC), power management, and system configuration module.

[SPRUFK4](#) — ***TMS320C6745/C6747 DSP System Reference Guide***. Describes the System-on-Chip (SoC) including the C6745/C6747 DSP subsystem, system memory, device clocking, phase-locked loop controller (PLL), power and sleep controller (PSC), power management, and system configuration module.

[SPRUG84](#) — ***OMAP-L137 Applications Processor System Reference Guide***. Describes the System-on-Chip (SoC) including the ARM subsystem, DSP subsystem, system memory, device clocking, phase-locked loop controller (PLL), power and sleep controller (PSC), power management, ARM interrupt controller (AINTC), and system configuration module.

[SPRUFK9](#) — ***TMS320C674x/OMAP-L1x Processor Peripherals Overview Reference Guide***. Provides an overview and briefly describes the peripherals available on the TMS320C674x Digital Signal Processors (DSPs) and OMAP-L1x Applications Processors.

[SPRUFK5](#) — ***TMS320C674x DSP Megamodule Reference Guide***. Describes the TMS320C674x digital signal processor (DSP) megamodule. Included is a discussion on the internal direct memory access (IDMA) controller, the interrupt controller, the power-down controller, memory protection, bandwidth management, and the memory and cache.

[SPRUFE8](#) — ***TMS320C674x DSP CPU and Instruction Set Reference Guide***. Describes the CPU architecture, pipeline, instruction set, and interrupts for the TMS320C674x digital signal processors (DSPs). The C674x DSP is an enhancement of the C64x+ and C67x+ DSPs with added functionality and an expanded instruction set.

[SPRUG82](#) — ***TMS320C674x DSP Cache User's Guide***. Explains the fundamentals of memory caches and describes how the two-level cache-based internal memory architecture in the TMS320C674x digital signal processor (DSP) can be efficiently used in DSP applications. Shows how to maintain coherence with external memory, how to use DMA to reduce memory latencies, and how to optimize your code to improve cache efficiency. The internal memory architecture in the C674x DSP is organized in a two-level hierarchy consisting of a dedicated program cache (L1P) and a dedicated data cache (L1D) on the first level. Accesses by the CPU to these first level caches can complete without CPU pipeline stalls. If the data requested by the CPU is not contained in cache, it is fetched from the next lower memory level, L2 or external memory.

Enhanced Quadrature Encoder Pulse (eQEP) Module

The enhanced quadrature encoder pulse (eQEP) module is used for direct interface with a linear or rotary incremental encoder to get position, direction, and speed information from a rotating machine for use in a high-performance motion and position-control system.

1 Introduction

A single track of slots patterns the periphery of an incremental encoder disk, as shown in [Figure 1](#). These slots create an alternating pattern of dark and light lines. The disk count is defined as the number of dark/light line pairs that occur per revolution (lines per revolution). As a rule, a second track is added to generate a signal that occurs once per revolution (index signal: QEPI), which can be used to indicate an absolute position. Encoder manufacturers identify the index pulse using different terms such as index, marker, home position, and zero reference.

Figure 1. Optical Encoder Disk

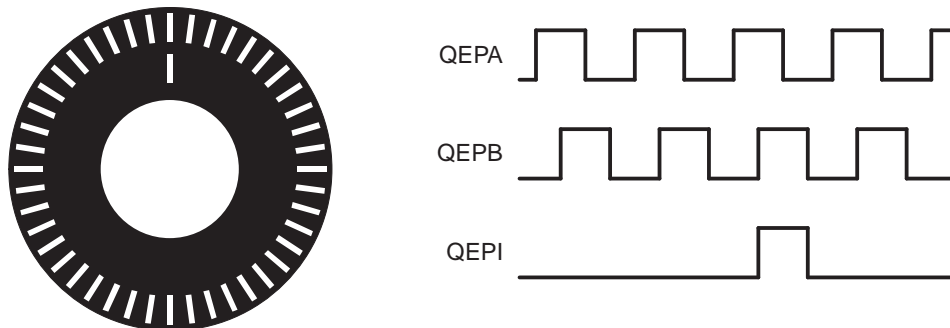

To derive direction information, the lines on the disk are read out by two different photo-elements that "look" at the disk pattern with a mechanical shift of 1/4 the pitch of a line pair between them. This shift is realized with a reticle or mask that restricts the view of the photo-element to the desired part of the disk lines. As the disk rotates, the two photo-elements generate signals that are shifted 90 degrees out of phase from each other. These are commonly called the quadrature QEPA and QEPB signals. The clockwise direction for most encoders is defined as the QEPA channel going positive before the QEPB channel and vice versa as shown in [Figure 2](#).

The encoder wheel typically makes one revolution for every revolution of the motor or the wheel may be at a geared rotation ratio with respect to the motor. Therefore, the frequency of the digital signal coming from the QEPA and QEPB outputs varies proportionally with the velocity of the motor. For example, a 2000-line encoder directly coupled to a motor running at 5000 revolutions per minute (rpm) results in a frequency of 166.6 KHz, so by measuring the frequency of either the QEPA or QEPB output, the processor can determine the velocity of the motor.

Figure 2. QEP Encoder Output Signal for Forward/Reverse Movement

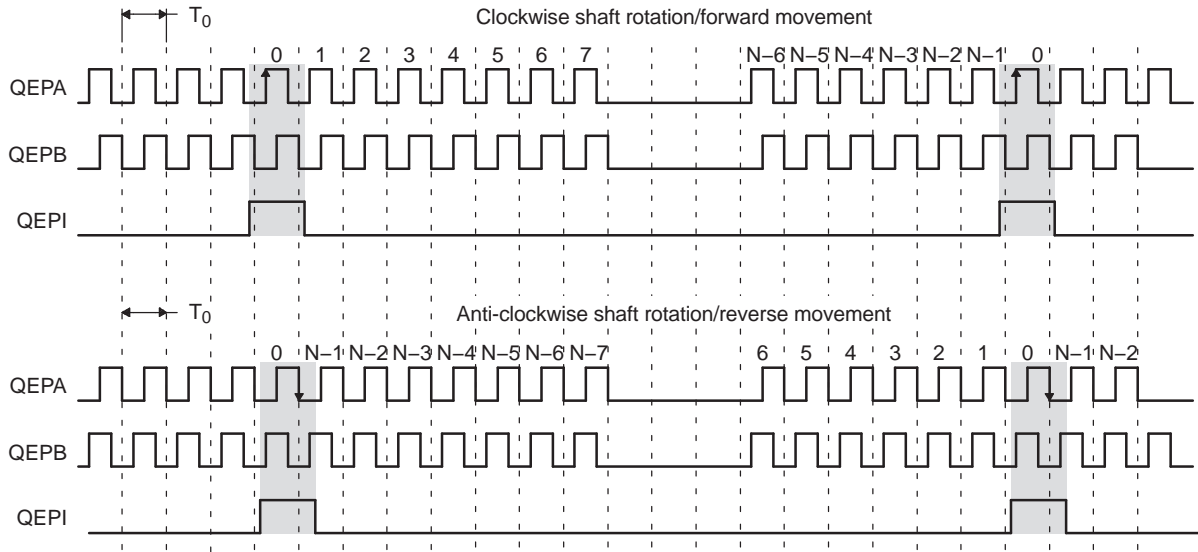

Legend: N = lines per revolution

Quadrature encoders from different manufacturers come with two forms of index pulse (gated index pulse or ungated index pulse) as shown in Figure 3. A nonstandard form of index pulse is ungated. In the ungated configuration, the index edges are not necessarily coincident with A and B signals. The gated index pulse is aligned to any of the four quadrature edges and width of the index pulse and can be equal to a quarter, half, or full period of the quadrature signal.

Figure 3. Index Pulse Example

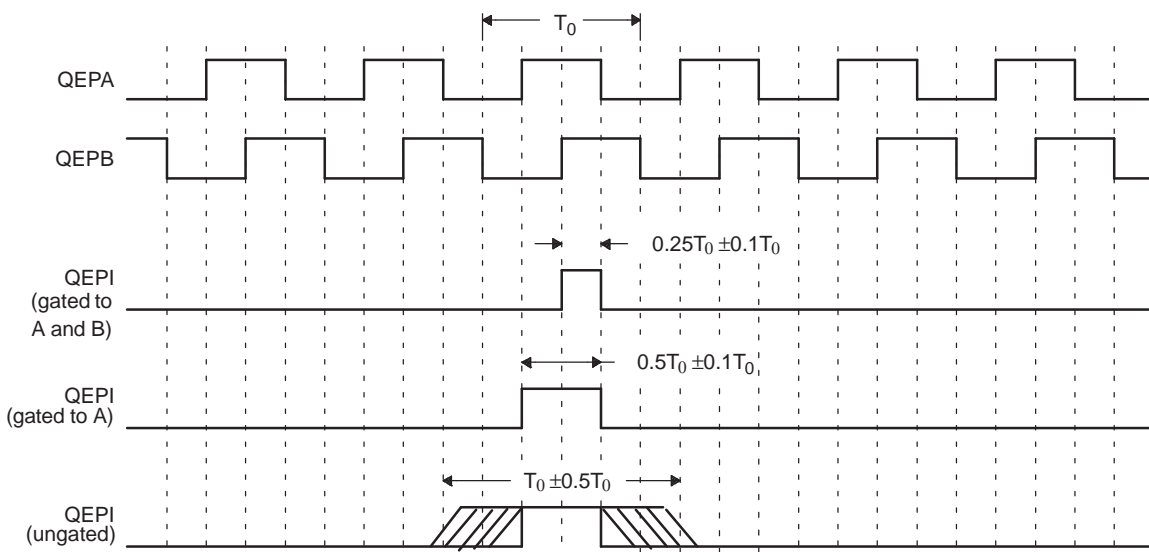

Some typical applications of shaft encoders include robotics and even computer input in the form of a mouse. Inside your mouse you can see where the mouse ball spins a pair of axles (a left/right, and an up/down axle). These axles are connected to optical shaft encoders that effectively tell the computer how fast and in what direction the mouse is moving.

General Issues: Estimating velocity from a digital position sensor is a cost-effective strategy in motor control. Two different first order approximations for velocity may be written as:

$$v(k) \approx \frac{x(k) - x(k - 1)}{T} = \frac{\Delta X}{T} \quad (1)$$

$$v(k) \approx \frac{X}{t(k) - t(k - 1)} = \frac{X}{\Delta T} \quad (2)$$

where

$v(k)$: Velocity at time instant k

$x(k)$: Position at time instant k

$x(k-1)$: Position at time instant $k - 1$

T : Fixed unit time or inverse of velocity calculation rate

ΔX : Incremental position movement in unit time

$t(k)$: Time instant "k"

$t(k-1)$: Time instant "k - 1"

X : Fixed unit position

ΔT : Incremental time elapsed for unit position movement.

[Equation 1](#) is the conventional approach to velocity estimation and it requires a time base to provide unit time event for velocity calculation. Unit time is basically the inverse of the velocity calculation rate.

The encoder count (position) is read once during each unit time event. The quantity $[x(k) - x(k-1)]$ is formed by subtracting the previous reading from the current reading. Then the velocity estimate is computed by multiplying by the known constant $1/T$ (where T is the constant time between unit time events and is known in advance).

Estimation based on [Equation 1](#) has an inherent accuracy limit directly related to the resolution of the position sensor and the unit time period T . For example, consider a 500-line per revolution quadrature encoder with a velocity calculation rate of 400 Hz. When used for position the quadrature encoder gives a four-fold increase in resolution, in this case, 2000 counts per revolution. The minimum rotation that can be detected is therefore 0.0005 revolutions, which gives a velocity resolution of 12 rpm when sampled at 400 Hz. While this resolution may be satisfactory at moderate or high speeds, for example, 1% error at 1200 rpm, it would clearly prove inadequate at low speeds. In fact, at speeds below 12 rpm, the speed estimate would erroneously be zero much of the time.

At low speed, [Equation 2](#) provides a more accurate approach. It requires a position sensor that outputs a fixed interval pulse train, such as the aforementioned quadrature encoder. The width of each pulse is defined by motor speed for a given sensor resolution. [Equation 2](#) can be used to calculate motor speed by measuring the elapsed time between successive quadrature pulse edges. However, this method suffers from the opposite limitation, as does [Equation 1](#). A combination of relatively large motor speeds and high sensor resolution makes the time interval ΔT small, and thus more greatly influenced by the timer resolution. This can introduce considerable error into high-speed estimates.

For systems with a large speed range (that is, speed estimation is needed at both low and high speeds), one approach is to use [Equation 2](#) at low speed and have the DSP software switch over to [Equation 1](#) when the motor speed rises above some specified threshold.

2 Architecture

This section provides the eQEP inputs and functional description.

Note: Multiple identical eQEP modules can be contained in a system. The number of modules is device-dependent and is based on target application needs. In this document, the letter x within a signal or module name is used to indicate a generic eQEP instance on a device.

2.1 EQEP Inputs

The eQEP inputs include two pins for quadrature-clock mode or direction-count mode, an index (or 0 marker), and a strobe input.

- QEPA/XCLK and QEPB/XDIR: These two pins can be used in quadrature-clock mode or direction-count mode.
 - Quadrature-clock Mode: The eQEP encoders provide two square wave signals (A and B) 90 electrical degrees out of phase whose phase relationship is used to determine the direction of rotation of the input shaft and number of eQEP pulses from the index position to derive the relative position information. For forward or clockwise rotation, QEPA signal leads QEPB signal and vice versa. The quadrature decoder uses these two inputs to generate quadrature-clock and direction signals.
 - Direction-count Mode: In direction-count mode, direction and clock signals are provided directly from the external source. Some position encoders have this type of output instead of quadrature output. The QEPA pin provides the clock input and the QEPB pin provides the direction input.
- QEPI: Index or Zero Marker: The eQEP encoder uses an index signal to assign an absolute start position from which position information is incrementally encoded using quadrature pulses. This pin is connected to the index output of the eQEP encoder to optionally reset the position counter for each revolution. This signal can be used to initialize or latch the position counter on the occurrence of a desired event on the index pin.
- QEPS: Strobe Input: This general-purpose strobe signal can initialize or latch the position counter on the occurrence of a desired event on the strobe pin. This signal is typically connected to a sensor or limit switch to notify that the motor has reached a defined position.

2.2 Functional Description

The eQEP peripheral contains the following major functional units (as shown in [Figure 4](#)):

- Programmable input qualification for each pin (part of the GPIO MUX)
- Quadrature decoder unit (QDU)
- Position counter and control unit for position measurement (PCCU)
- Quadrature edge-capture unit for low-speed measurement (QCAP)
- Unit time base for speed/frequency measurement (UTIME)
- Watchdog timer for detecting stalls (QWDOG)

Figure 4. Functional Block Diagram of the eQEP Peripheral

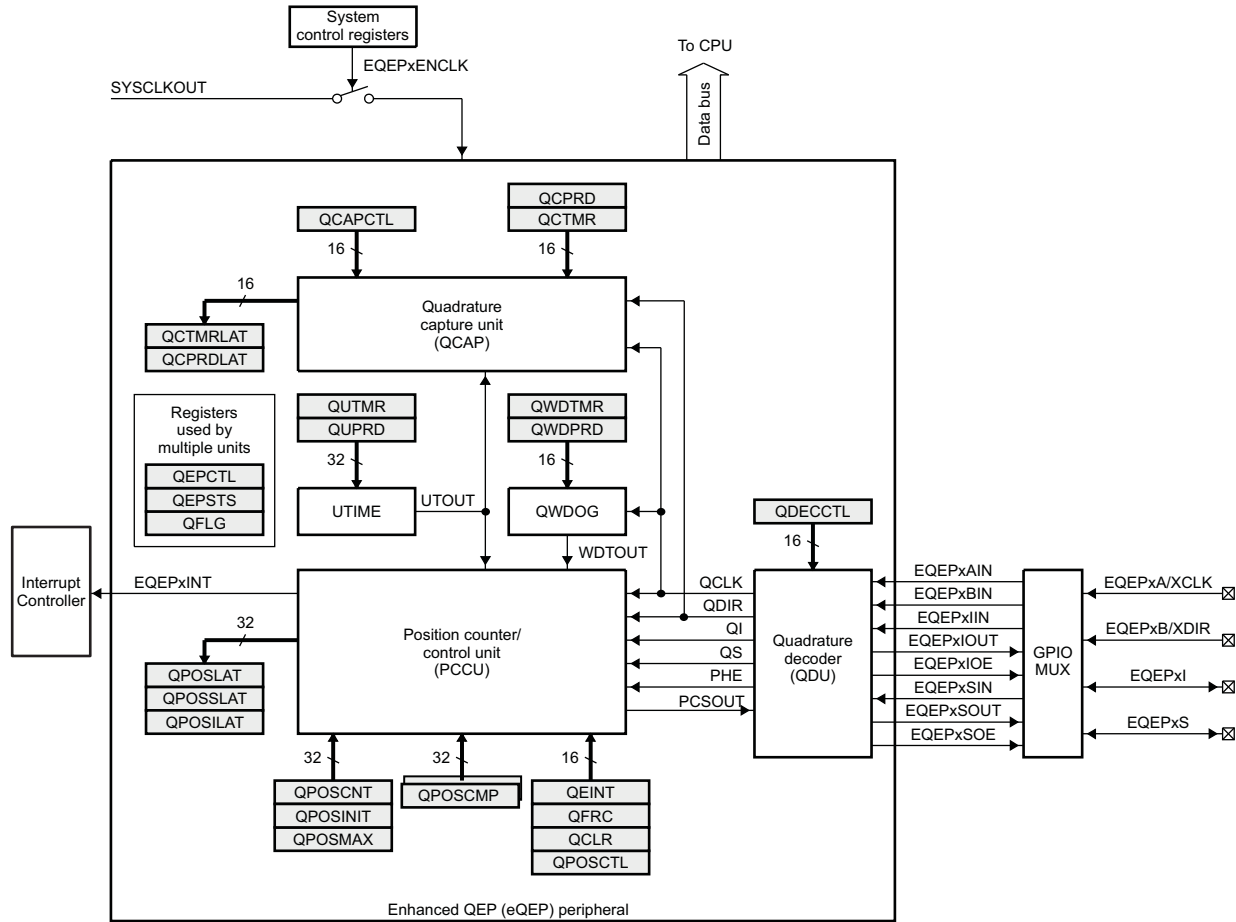

2.3 Quadrature Decoder Unit (QDU)

Figure 5 shows a functional block diagram of the QDU.

Figure 5. Functional Block Diagram of Decoder Unit

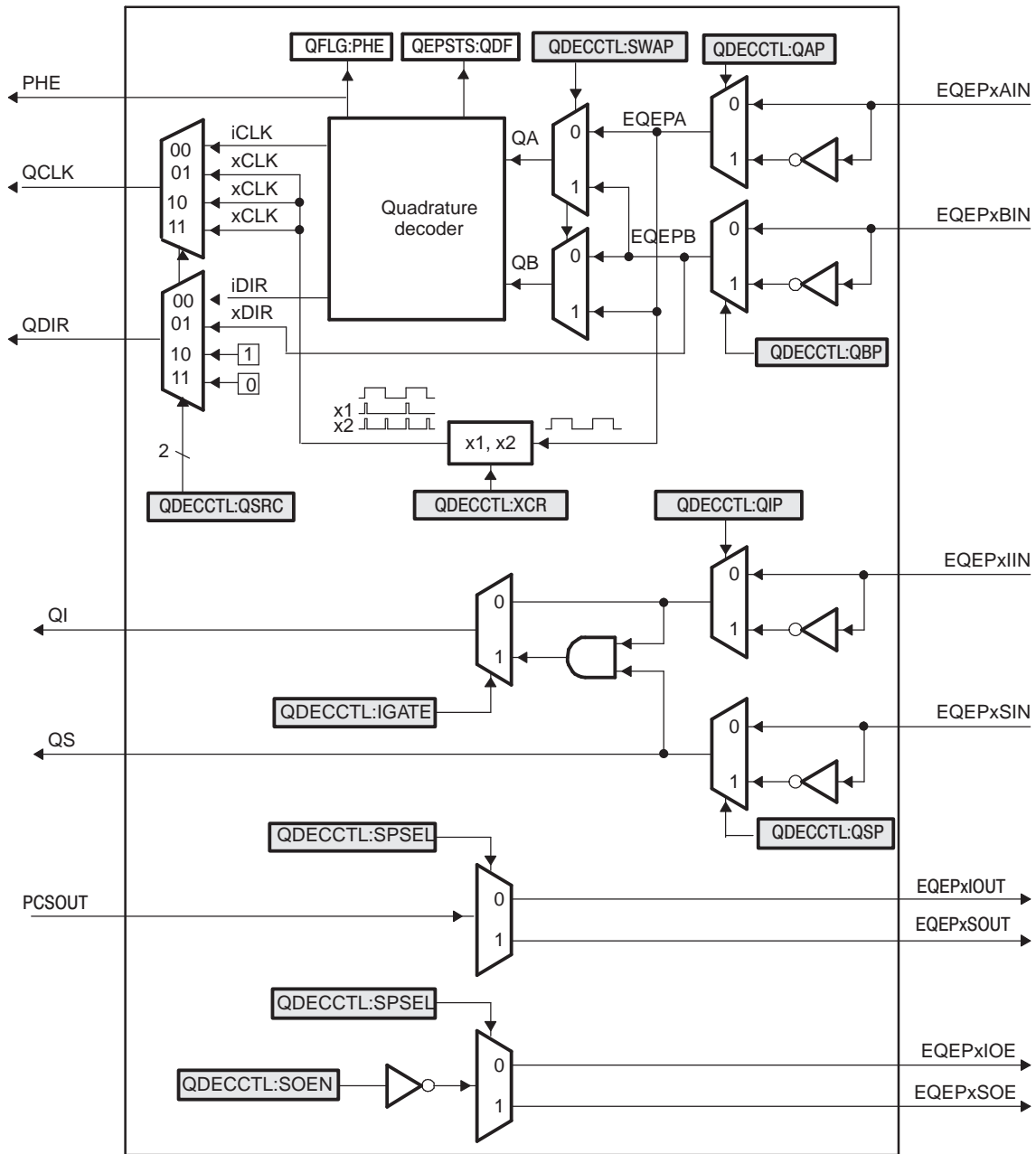

2.3.1 Position Counter Input Modes

Clock and direction input to position counter is selected using the QSRC bit in the eQEP decoder control register (QDECCTL), based on interface input requirement as follows:

- Quadrature-count mode
- Direction-count mode
- UP-count mode
- DOWN-count mode

2.3.1.1 Quadrature Count Mode

The quadrature decoder generates the direction and clock to the position counter in quadrature count mode.

Direction Decoding—The direction decoding logic of the eQEP circuit determines which one of the sequences (QEPA, QEPB) is the leading sequence and accordingly updates the direction information in the QDF bit in the eQEP status register (QEPSTS). [Table 1](#) and [Figure 6](#) show the direction decoding logic in truth table and state machine form. Both edges of the QEPA and QEPB signals are sensed to generate count pulses for the position counter. Therefore, the frequency of the clock generated by the eQEP logic is four times that of each input sequence. [Figure 7](#) shows the direction decoding and clock generation from the eQEP input signals.

Phase Error Flag—In normal operating conditions, quadrature inputs QEPA and QEPB will be 90 degrees out of phase. The phase error flag (PHE) is set in the QFLG register when edge transition is detected simultaneously on the QEPA and QEPB signals to optionally generate interrupts. State transitions marked by dashed lines in [Figure 6](#) are invalid transitions that generate a phase error.

Count Multiplication—The eQEP position counter provides 4x times the resolution of an input clock by generating a quadrature-clock (QCLK) on the rising/falling edges of both eQEP input clocks (QEPA and QEPB) as shown in [Figure 7](#).

Reverse Count—In normal quadrature count operation, QEPA input is fed to the QA input of the quadrature decoder and the QEPB input is fed to the QB input of the quadrature decoder. Reverse counting is enabled by setting the SWAP bit in the eQEP decoder control register (QDECCTL). This will swap the input to the quadrature decoder thereby reversing the counting direction.

Table 1. Quadrature Decoder Truth Table

| Previous Edge | Present Edge | QDIR | QPOSCNT |
|---------------|--------------|--------|------------------------|
| QA↑ | QB↑ | UP | Increment |
| | QB↓ | DOWN | Decrement |
| | QA↓ | TOGGLE | Increment or Decrement |
| QA↓ | QB↓ | UP | Increment |
| | QB↑ | DOWN | Decrement |
| | QA↑ | TOGGLE | Increment or Decrement |
| QB↑ | QA↑ | DOWN | Increment |
| | QA↓ | UP | Decrement |
| | QB↓ | TOGGLE | Increment or Decrement |
| QB↓ | QA↓ | DOWN | Increment |
| | QA↑ | UP | Decrement |
| | QB↑ | TOGGLE | Increment or Decrement |

Figure 6. Quadrature Decoder State Machine

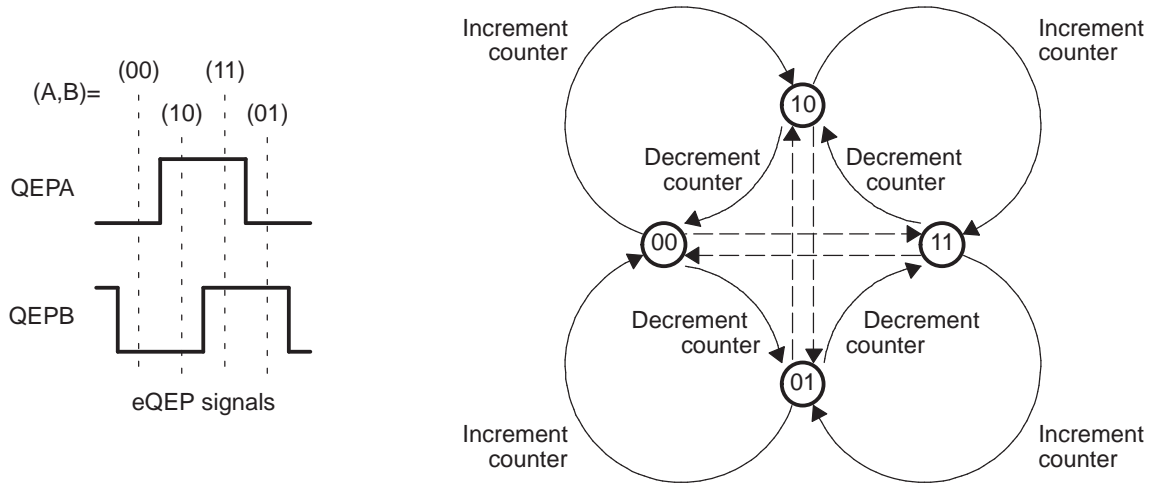
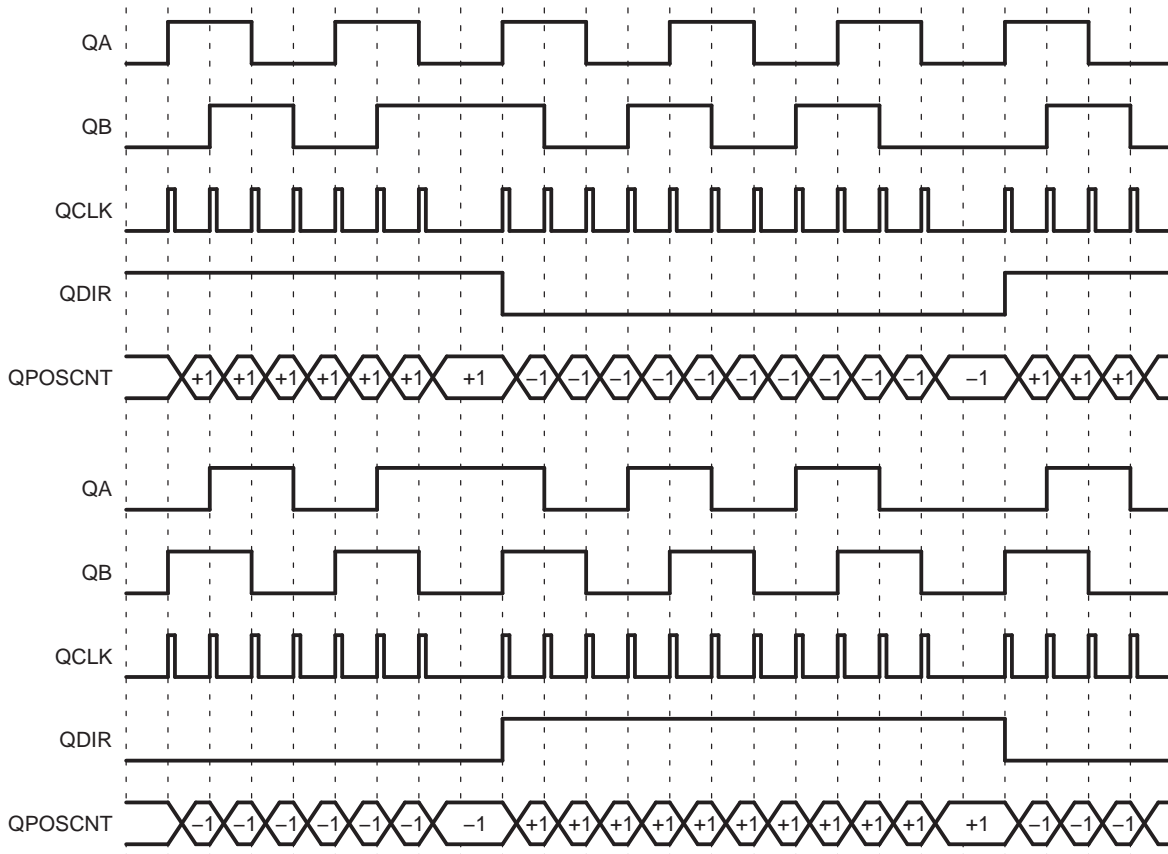

Figure 7. Quadrature-clock and Direction Decoding



2.3.1.2 Direction-count Mode

Some position encoders provide direction and clock outputs, instead of quadrature outputs. In such cases, direction-count mode can be used. QEPA input will provide the clock for position counter and the QEPB input will have the direction information. The position counter is incremented on every rising edge of a QEPA input when the direction input is high and decremented when the direction input is low.

2.3.1.3 Up-Count Mode

The counter direction signal is hard-wired for up count and the position counter is used to measure the frequency of the QEPA input. Setting of the XCR bit in the eQEP decoder control register (QDECCTL) enables clock generation to the position counter on both edges of the QEPA input, thereby increasing the measurement resolution by 2× factor.

2.3.1.4 Down-Count Mode

The counter direction signal is hardwired for a down count and the position counter is used to measure the frequency of the QEPA input. Setting of the XCR bit in the eQEP decoder control register (QDECCTL) enables clock generation to the position counter on both edges of a QEPA input, thereby increasing the measurement resolution by 2× factor.

2.3.2 eQEP Input Polarity Selection

Each eQEP input can be inverted using the in the eQEP decoder control register (QDECCTL[8:5]) control bits. As an example, setting of the QIP bit in QDECCTL inverts the index input.

2.3.3 Position-Compare Sync Output

The eQEP peripheral includes a position-compare unit that is used to generate the position-compare sync signal on compare match between the position counter register (QPOSCNT) and the position-compare register (QPOSCMP). This sync signal can be output using an index pin or strobe pin of the EQEP peripheral.

Setting the SOEN bit in the eQEP decoder control register (QDECCTL) enables the position-compare sync output and the SPSEL bit in QDECCTL selects either an eQEP index pin or an eQEP strobe pin.

2.4 Position Counter and Control Unit (PCCU)

The position counter and control unit provides two configuration registers (QEPCTL and QPOSCTL) for setting up position counter operational modes, position counter initialization/latch modes and position-compare logic for sync signal generation.

2.4.1 Position Counter Operating Modes

Position counter data may be captured in different manners. In some systems, the position counter is accumulated continuously for multiple revolutions and the position counter value provides the position information with respect to the known reference. An example of this is the quadrature encoder mounted on the motor controlling the print head in the printer. Here the position counter is reset by moving the print head to the home position and then position counter provides absolute position information with respect to home position.

In other systems, the position counter is reset on every revolution using index pulse and position counter provides rotor angle with respect to index pulse position.

Position counter can be configured to operate in following four modes

- Position Counter Reset on Index Event
- Position Counter Reset on Maximum Position
- Position Counter Reset on the first Index Event
- Position Counter Reset on Unit Time Out Event (Frequency Measurement)

In all the above operating modes, position counter is reset to 0 on overflow and to QPOS MAX register value on underflow. Overflow occurs when the position counter counts up after QPOS MAX value. Underflow occurs when position counter counts down after "0". Interrupt flag is set to indicate overflow/underflow in QFLG register.

2.4.1.1 Position Counter Reset on Index Event (QEPCTL[PCRM] = 00)

If the index event occurs during the forward movement, then position counter is reset to 0 on the next eQEP clock. If the index event occurs during the reverse movement, then the position counter is reset to the value in the QPOS MAX register on the next eQEP clock.

First index marker is defined as the quadrature edge following the first index edge. The eQEP peripheral records the occurrence of the first index marker (QEPSTS[FIMF]) and direction on the first index event marker (QEPSTS[FIDF]) in QEPSTS registers, it also remembers the quadrature edge on the first index marker so that same relative quadrature transition is used for index event reset operation.

For example, if the first reset operation occurs on the falling edge of QEPB during the forward direction, then all the subsequent reset must be aligned with the falling edge of QEPB for the forward rotation and on the rising edge of QEPB for the reverse rotation as shown in Figure 8.

The position-counter value is latched to the QPOSILAT register and direction information is recorded in the QEPSTS[QDLF] bit on every index event marker. The position-counter error flag (QEPSTS[PCEF]) and error interrupt flag (QFLG[PCE]) are set if the latched value is not equal to 0 or QPOS MAX. The position-counter error flag (QEPSTS[PCEF]) is updated on every index event marker and an interrupt flag (QFLG[PCE]) will be set on error that can be cleared only through software.

The index event latch configuration QEPCTL[IEL] bits are ignored in this mode and position counter error flag/interrupt flag are generated only in index event reset mode.

Figure 8. Position Counter Reset by Index Pulse for 1000 Line Encoder (QPOS MAX = 3999 or F9Fh)

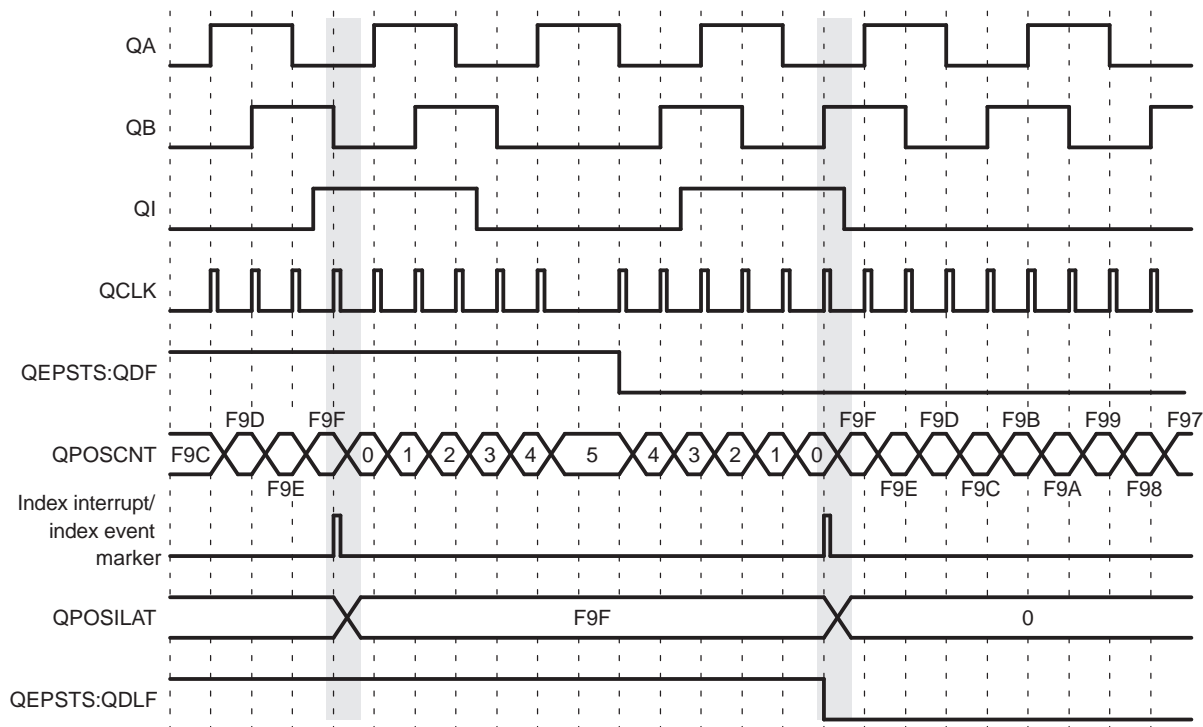

2.4.1.2 Position Counter Reset on Maximum Position (QEPCTL[PCRM]=01)

If the position counter is equal to QPOS MAX, then the position counter is reset to 0 on the next eQEP clock for forward movement and position counter overflow flag is set. If the position counter is equal to ZERO, then the position counter is reset to QPOS MAX on the next QEP clock for reverse movement and position counter underflow flag is set. Figure 9 shows the position counter reset operation in this mode.

First index marker is defined as the quadrature edge following the first index edge. The eQEP peripheral records the occurrence of the first index marker (QEPSTS[FIMF]) and direction on the first index event marker (QEPSTS[FIDF]) in the QEPSTS registers; it also remembers the quadrature edge on the first index marker so that the same relative quadrature transition is used for the software index marker (QEPCTL[IEL]=11).

Figure 9. Position Counter Underflow/Overflow (QPOS MAX = 4)

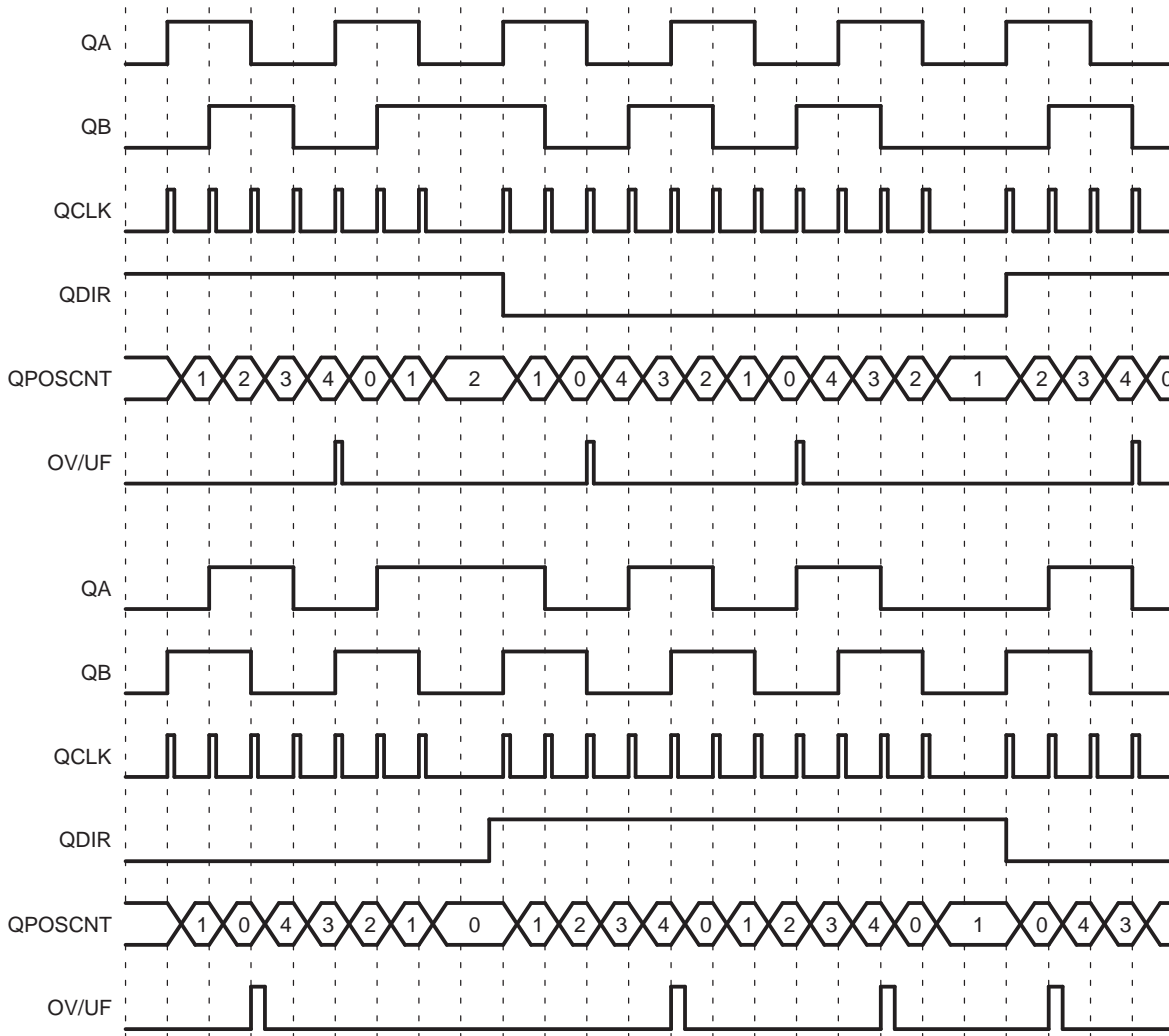

2.4.1.3 Position Counter Reset on the First Index Event (QEPCTL[PCRM] = 10)

If the index event occurs during forward movement, then the position counter is reset to 0 on the next eQEP clock. If the index event occurs during the reverse movement, then the position counter is reset to the value in the QPOSMAX register on the next eQEP clock. Note that this is done only on the first occurrence and subsequently the position counter value is not reset on an index event; rather, it is reset based on maximum position as described in [Section 2.4.1.2](#).

First index marker is defined as the quadrature edge following the first index edge. The eQEP peripheral records the occurrence of the first index marker (QEPSTS[FIMF]) and direction on the first index event marker (QEPSTS[FIDF]) in QEPSTS registers. It also remembers the quadrature edge on the first index marker so that same relative quadrature transition is used for software index marker (QEPCTL[IEL]=11).

2.4.1.4 Position Counter Reset on Unit Time out Event (QEPCTL[PCRM] = 11)

In this mode, the QPOSCNT value is latched to the QPOSLAT register and then the QPOSCNT is reset (to 0 or QPOSMAX, depending on the direction mode selected by QDECCTL[QSRC] bits on a unit time event). This is useful for frequency measurement.

2.4.2 Position Counter Latch

The eQEP index and strobe input can be configured to latch the position counter (QPOSCNT) into QPOSILAT and QPOSSLAT, respectively, on occurrence of a definite event on these pins.

2.4.2.1 Index Event Latch

In some applications, it may not be desirable to reset the position counter on every index event and instead it may be required to operate the position counter in full 32-bit mode (QEPCTL[PCRM] = 01 and QEPCTL[PCRM] = 10 modes).

In such cases, the eQEP position counter can be configured to latch on the following events and direction information is recorded in the QEPSTS[QDLF] bit on every index event marker.

- Latch on Rising edge (QEPCTL[IEL] = 01)
- Latch on Falling edge (QEPCTL[IEL] = 10)
- Latch on Index Event Marker (QEPCTL[IEL] = 11)

This is particularly useful as an error checking mechanism to check if the position counter accumulated the correct number of counts between index events. As an example, the 1000-line encoder must count 4000 times when moving in the same direction between the index events.

The index event latch interrupt flag (QFLG[IEL]) is set when the position counter is latched to the QPOSILAT register. The index event latch configuration bits (QEPCTZ[IEL]) are ignored when QEPCTL[PCRM] = 00.

Latch on Rising Edge (QEPCTL[IEL] = 01)—The position counter value (QPOSCNT) is latched to the QPOSILAT register on every rising edge of an index input.

Latch on Falling Edge (QEPCTL[IEL] = 10)—The position counter value (QPOSCNT) is latched to the QPOSILAT register on every falling edge of index input.

Latch on Index Event Marker/Software Index Marker (QEPCTL[IEL] = 11)—The first index marker is defined as the quadrature edge following the first index edge. The eQEP peripheral records the occurrence of the first index marker (QEPSTS[FIMF]) and direction on the first index event marker (QEPSTS[FIDF]) in the QEPSTS registers. It also remembers the quadrature edge on the first index marker so that same relative quadrature transition is used for latching the position counter (QEPCTL[IEL] = 11).

[Figure 10](#) shows the position counter latch using an index event marker.

Figure 10. Software Index Marker for 1000-line Encoder (QEPCTL[IEL] = 1)

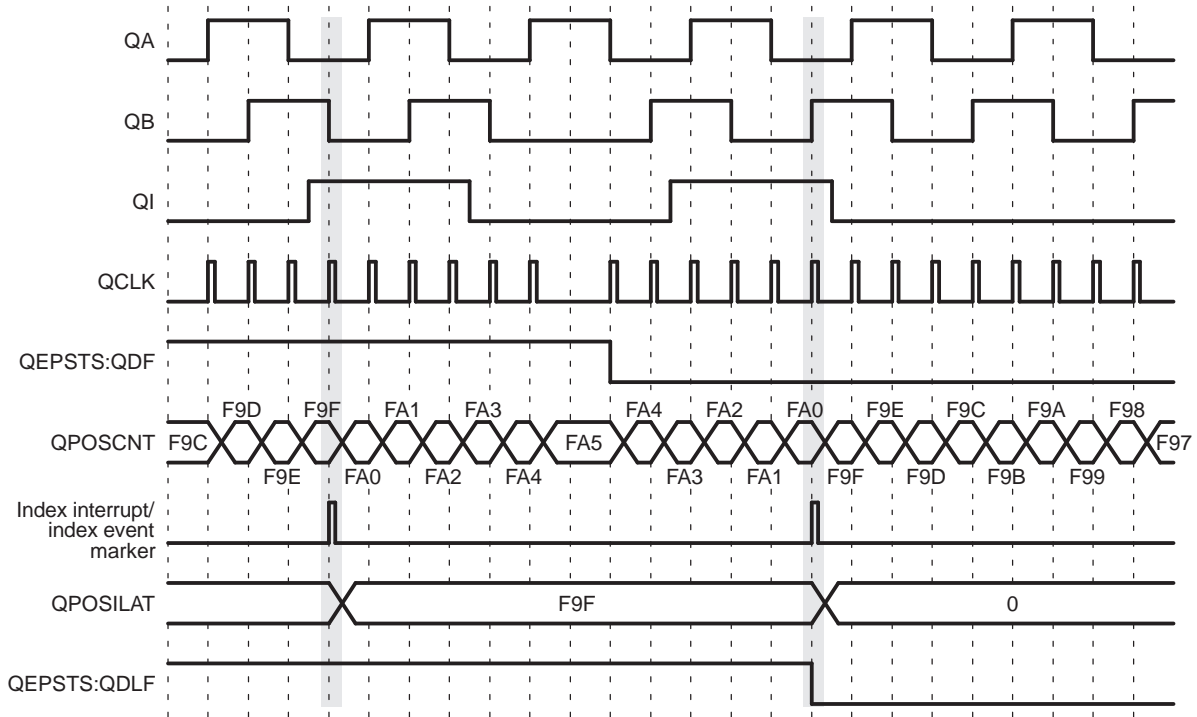

2.4.2.2 Strobe Event Latch

The position-counter value is latched to the QPOSSLAT register on the rising edge of the strobe input by clearing the QEPCTL[SEL] bit.

If the QEPCTL[SEL] bit is set, then the position counter value is latched to the QPOSSLAT register on the rising edge of the strobe input for forward direction and on the falling edge of the strobe input for reverse direction as shown in Figure 11.

The strobe event latch interrupt flag (QFLG[SEL]) is set when the position counter is latched to the QPOSSLAT register.

Figure 11. Strobe Event Latch (QEPCTL[SEL] = 1)

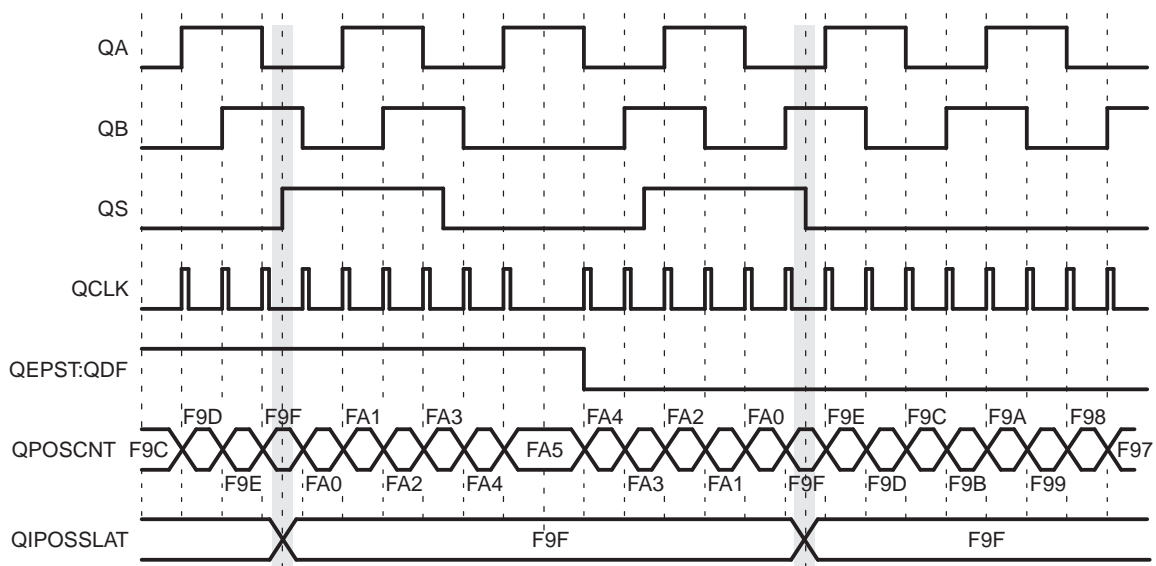

2.4.3 Position Counter Initialization

The position counter can be initialized using following events:

- Index event
- Strobe event
- Software initialization

Index Event Initialization (IEI)—The QEPI index input can be used to trigger the initialization of the position counter at the rising or falling edge of the index input.

If the QEPCTL[IEI] bits are 10, then the position counter (QPOSCNT) is initialized with a value in the QPOSINIT register on the rising edge of strobe input for forward direction and on the falling edge of strobe input for reverse direction.

The index event initialization interrupt flag (QFLG[IEI]) is set when the position counter is initialized with a value in the QPOSINIT register.

Strobe Event Initialization (SEI)—If the QEPCTL[SEI] bits are 10, then the position counter is initialized with a value in the QPOSINIT register on the rising edge of strobe input.

If the QEPCTL[SEL] bits are 11, then the position counter (QPOSCNT) is initialized with a value in the QPOSINIT register on the rising edge of strobe input for forward direction and on the falling edge of strobe input for reverse direction.

The strobe event initialization interrupt flag (QFLG[SEI]) is set when the position counter is initialized with a value in the QPOSINIT register.

Software Initialization (SWI)—The position counter can be initialized in software by writing a 1 to the QEPCTL[SWI] bit, which will automatically be cleared after initialization.

2.4.4 eQEP Position-compare Unit

The eQEP peripheral includes a position-compare unit that is used to generate a sync output and/or interrupt on a position-compare match. Figure 12 shows a diagram. The position-compare (QPOSCMP) register is shadowed and shadow mode can be enabled or disabled using the QPOSCTL[PSSHDW] bit. If the shadow mode is not enabled, the CPU writes directly to the active position compare register.

Figure 12. eQEP Position-compare Unit

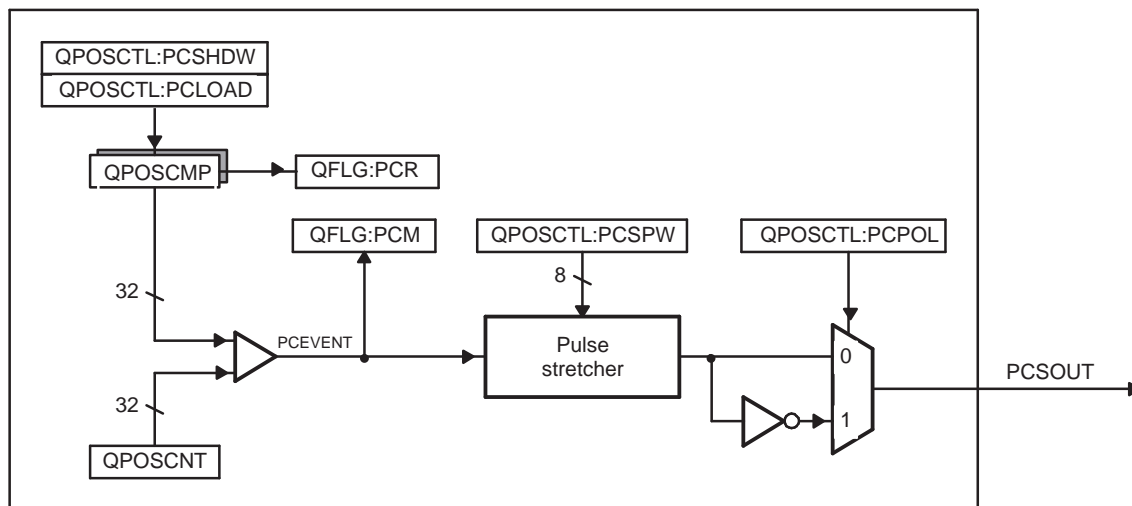

In shadow mode, you can configure the position-compare unit (QPOSCTL[PCLOAD]) to load the shadow register value into the active register on the following events and to generate the position-compare ready (QFLG[PCR]) interrupt after loading.

- Load on compare match
- Load on position-counter zero event

The position-compare match (QFLG[PCM]) is set when the position-counter value (QPOSCNT) matches with the active position-compare register (QPOSCMP) and the position-compare sync output of the programmable pulse width is generated on compare match to trigger an external device.

For example, if QPOSCMP = 2, the position-compare unit generates a position-compare event on 1 to 2 transitions of the eQEP position counter for forward counting direction and on 3 to 2 transitions of the eQEP position counter for reverse counting direction (see Figure 13).

Figure 35 shows the layout of the eQEP Position-Compare Control Register (QPOSCTL) and Table 17 describes the QPOSCTL bit fields.

Figure 13. eQEP Position-compare Event Generation Points

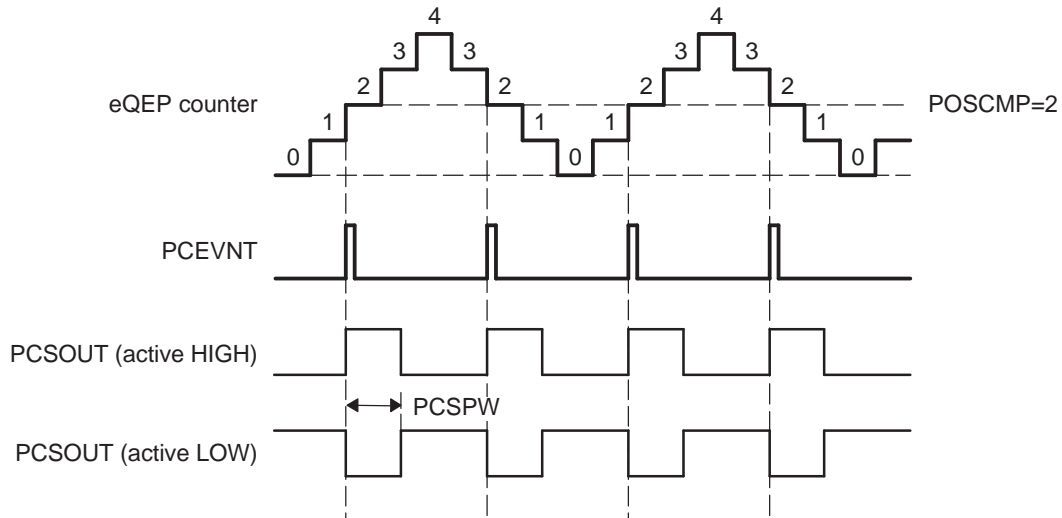

The pulse stretcher logic in the position-compare unit generates a programmable position-compare sync pulse output on the position-compare match. In the event of a new position-compare match while a previous position-compare pulse is still active, then the pulse stretcher generates a pulse of specified duration from the new position-compare event as shown in Figure 14.

Figure 14. eQEP Position-compare Sync Output Pulse Stretcher

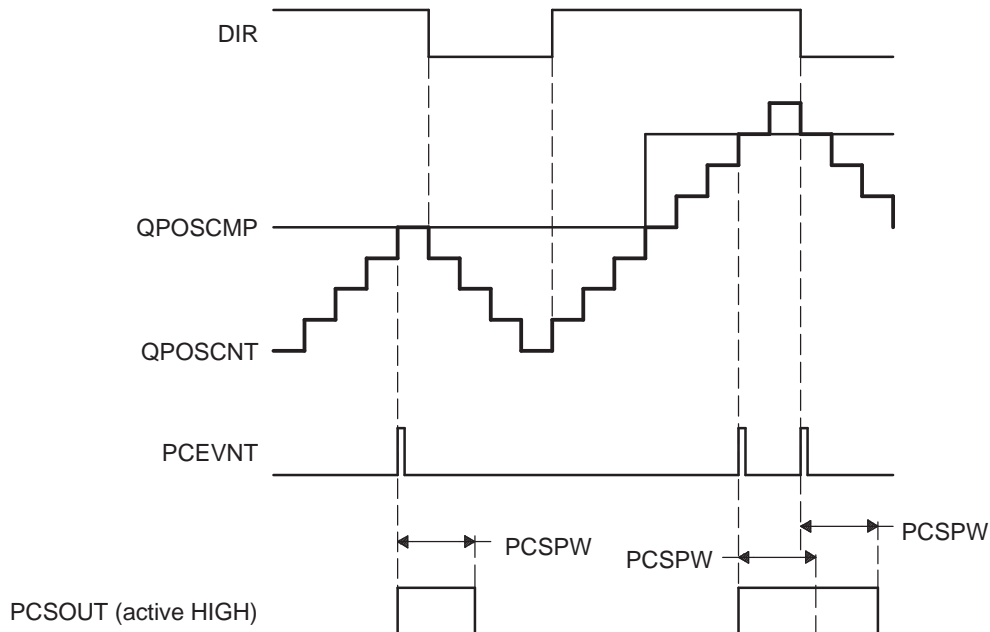

2.5 eQEP Edge Capture Unit

The eQEP peripheral includes an integrated edge capture unit to measure the elapsed time between the unit position events as shown in [Figure 15](#). This feature is typically used for low speed measurement using the following equation:

$$v(k) = \frac{X}{t(k) - t(k - 1)} = \frac{X}{\Delta T} \quad (3)$$

where,

- X - Unit position is defined by integer multiple of quadrature edges (see [Figure 16](#))
- ΔT - Elapsed time between unit position events
- v(k) - Velocity at time instant "k"

The eQEP capture timer (QCTMR) runs from prescaled SYSCLKOUT and the prescaler is programmed by the QCAPCTL[CCPS] bits. The capture timer (QCTMR) value is latched into the capture period register (QCPRD) on every unit position event and then the capture timer is reset, a flag is set in QEPSTS[UPEVNT] to indicate that new value is latched into the QCPRD register. Software can check this status flag before reading the period register for low speed measurement and clear the flag by writing 1.

Time measurement (ΔT) between unit position events will be correct if the following conditions are met:

- No more than 65,535 counts have occurred between unit position events.
- No direction change between unit position events.

The capture unit sets the eQEP overflow error flag (QEPSTS[COEF]) in the event of capture timer overflow between unit position events. If a direction change occurs between the unit position events, then an error flag is set in the status register (QEPSTS[CDEF]).

Capture Timer (QCTMR) and Capture period register (QCPRD) can be configured to latch on following events.

- CPU read of QPOSCNT register
- Unit time-out event

If the QEPCTL[QCLM] bit is cleared, then the capture timer and capture period values are latched into the QCTMRLAT and QCPRDLAT registers, respectively, when the CPU reads the position counter (QPOSCNT).

If the QEPCTL[QCLM] bit is set, then the position counter, capture timer, and capture period values are latched into the QPOSLAT, QCTMRLAT and QCPRDLAT registers, respectively, on unit time out.

[Figure 17](#) shows the capture unit operation along with the position counter.

Note: The QCAPCTL register should not be modified dynamically (such as switching CAPCLK prescaling mode from QCLK/4 to QCLK/8). The capture unit must be disabled before changing the prescaler.

Figure 15. eQEP Edge Capture Unit

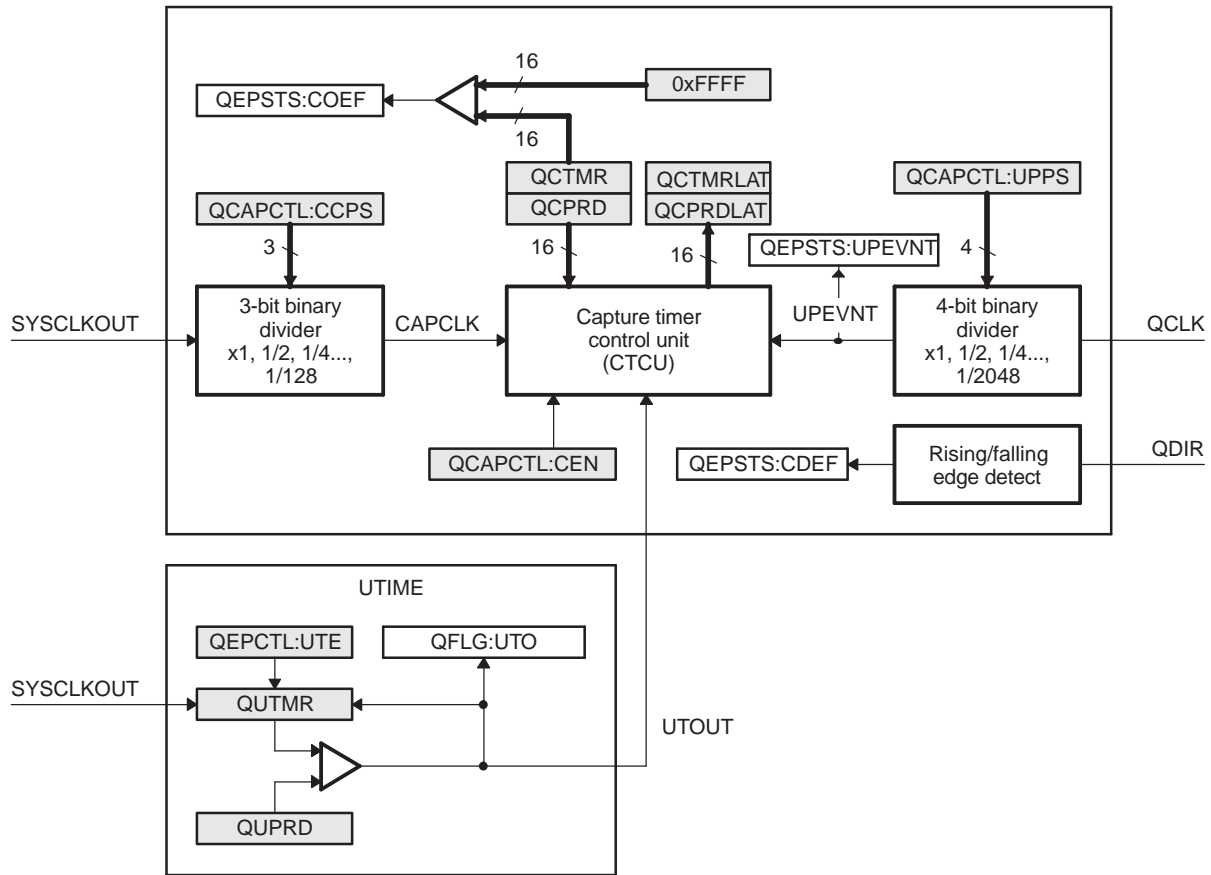
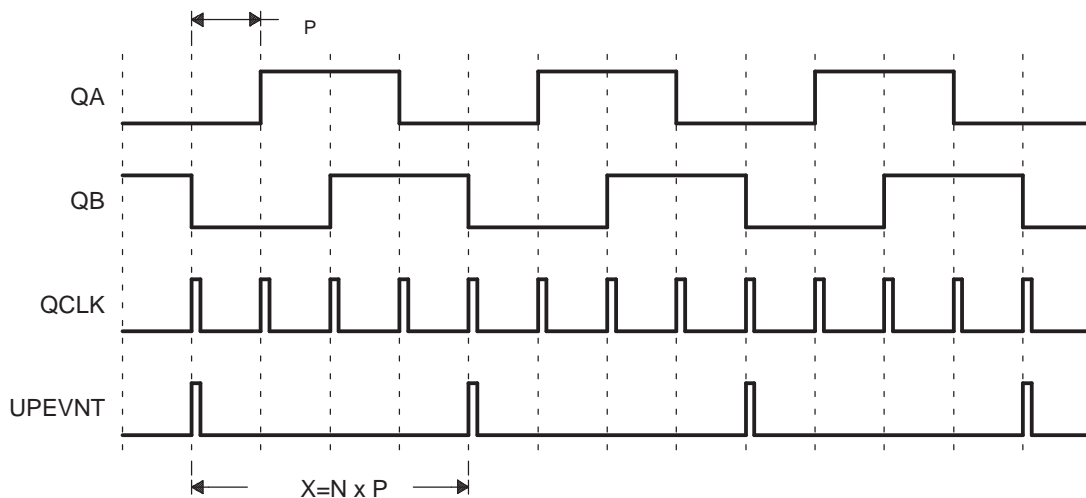
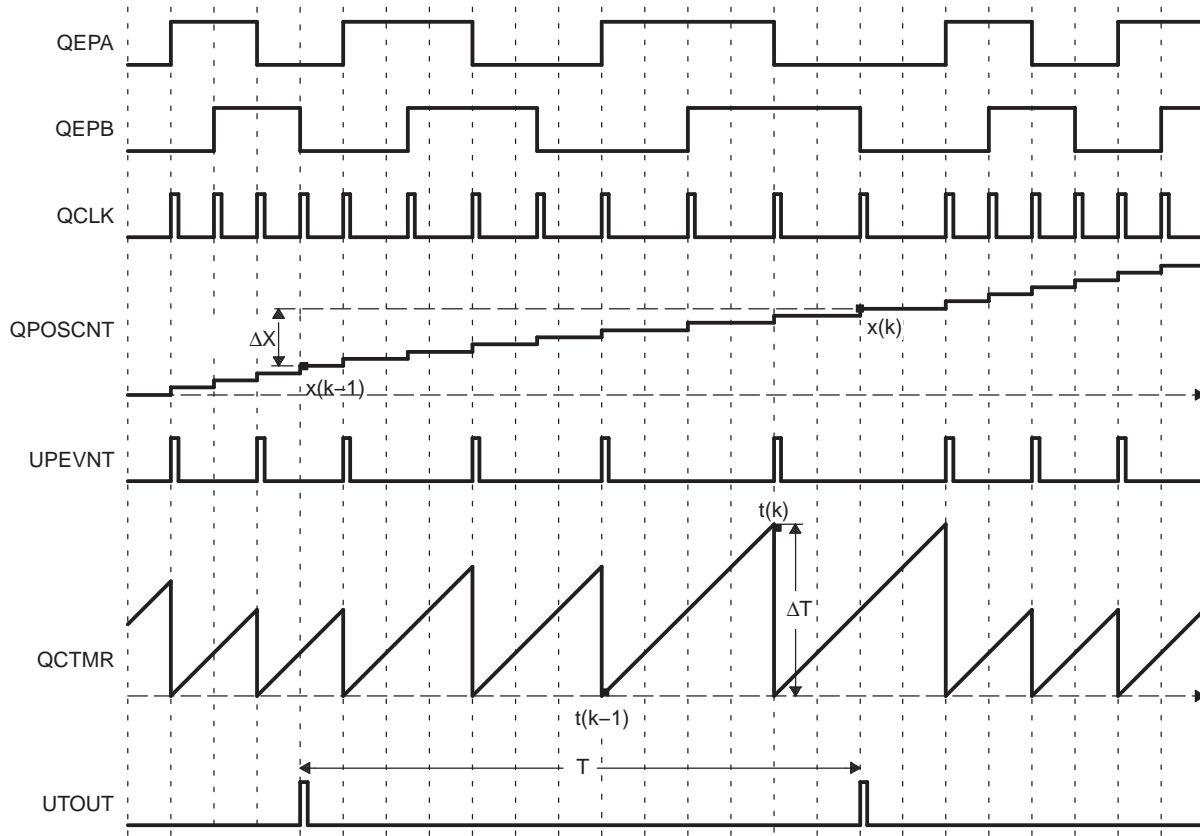

Figure 16. Unit Position Event for Low Speed Measurement (QCAPCTL[UPPS] = 0010)



N - Number of quadrature periods selected using QCAPCTL[UPPS] bits

Figure 17. eQEP Edge Capture Unit - Timing Details



Velocity Calculation Equations:

$$v(k) = \frac{x(k) - x(k - 1)}{T} = \frac{\Delta X}{T} \quad (4)$$

where

v(k): Velocity at time instant k

x(k): Position at time instant k

x(k-1): Position at time instant k - 1

T: Fixed unit time or inverse of velocity calculation rate

ΔX: Incremental position movement in unit time

X: Fixed unit position

ΔT: Incremental time elapsed for unit position movement

t(k): Time instant "k"

t(k-1): Time instant "k - 1"

Unit time (T) and unit period (X) are configured using the QUPRD and QCAPCTL[UPPS] registers. Incremental position output and incremental time output is available in the QPOSLAT and QCPRDLAT registers.

| Parameter | Relevant Register to Configure or Read the Information |
|------------|---|
| T | Unit Period Register (QUPRD) |
| ΔX | Incremental Position = QOSLAT(k) - QOSLAT(K - 1) |
| X | Fixed unit position defined by sensor resolution and ZCAPCTL[Upps] bits |
| ΔT | Capture Period Latch (QCPRDLAT) |

2.6 eQEP Watchdog

The eQEP peripheral contains a 16-bit watchdog timer that monitors the quadrature-clock to indicate proper operation of the motion-control system. The eQEP watchdog timer is clocked from SYSCLKOUT/64 and the quadrature clock event (pulse) resets the watchdog timer. If no quadrature-clock event is detected until a period match ($QWDPRD = QWDTMR$), then the watchdog timer will time out and the watchdog interrupt flag will be set (QFLG[WTO]). The time-out value is programmable through the watchdog period register (QWDPRD).

Figure 18. eQEP Watchdog Timer

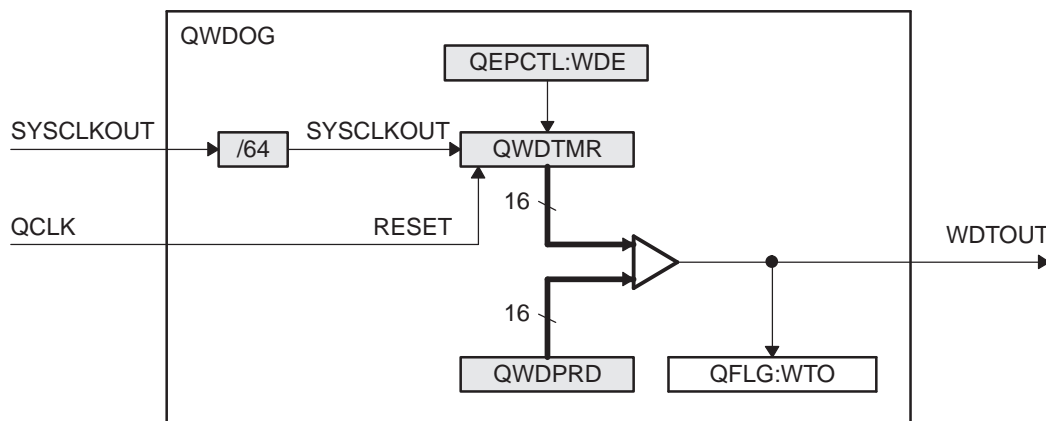

2.7 Unit Timer Base

The eQEP peripheral includes a 32-bit timer (QUTMR) that is clocked by SYSCLKOUT to generate periodic interrupts for velocity calculations. The unit time out interrupt is set (QFLG[UTO]) when the unit timer (QUTMR) matches the unit period register (QUPRD).

The eQEP peripheral can be configured to latch the position counter, capture timer, and capture period values on a unit time out event so that latched values are used for velocity calculation as described in Section 2.5.

Figure 19. eQEP Unit Time Base

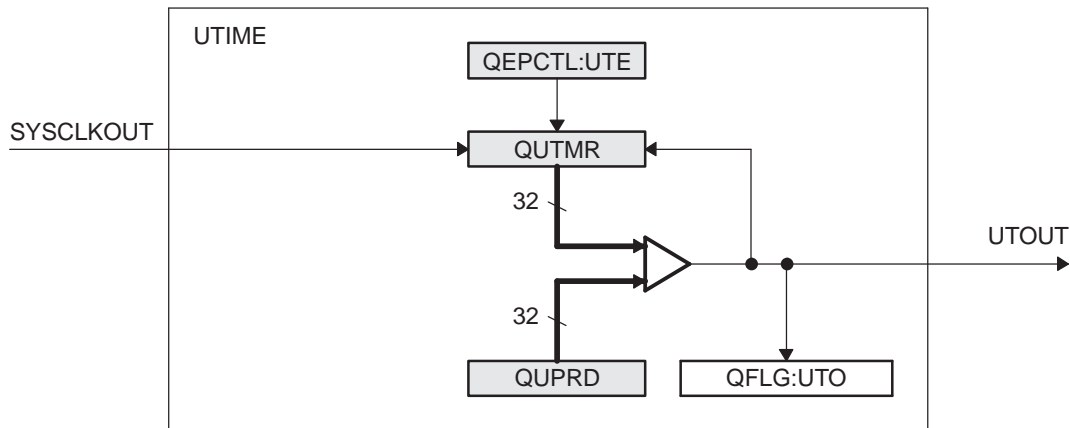

2.8 eQEP Interrupt Structure

Figure 20 shows how the interrupt mechanism works in the EQEP module.

Figure 20. EQEP Interrupt Generation

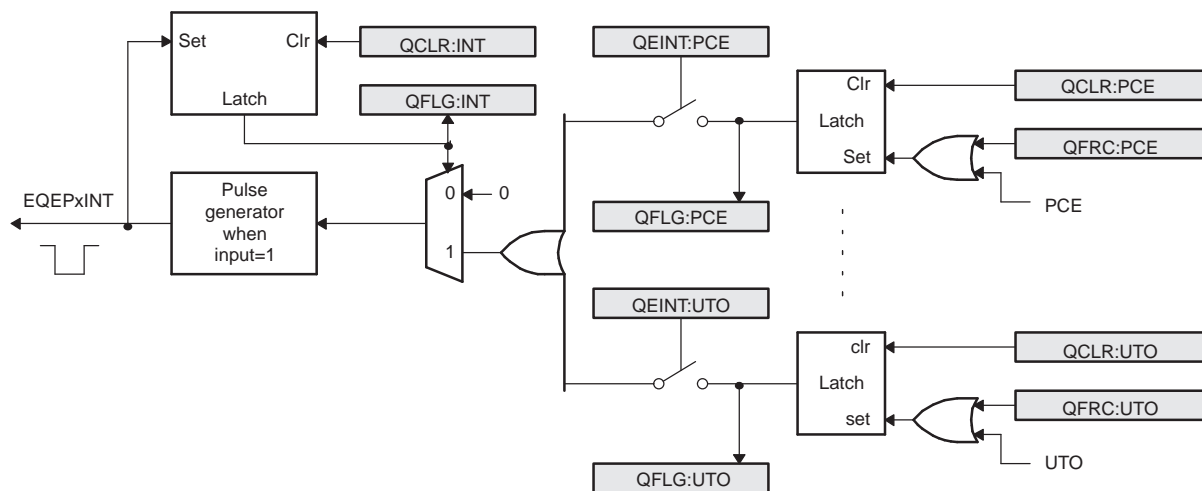

Eleven interrupt events (PCE, PHE, QDC, WTO, PCU, PCO, PCR, PCM, SEL, IEL, and UTO) can be generated. The interrupt control register (QEINT) is used to enable/disable individual interrupt event sources. The interrupt flag register (QFLG) indicates if any interrupt event has been latched and contains the global interrupt flag bit (INT). An interrupt pulse is generated only to the interrupt controller if any of the interrupt events is enabled, the flag bit is 1 and the INT flag bit is 0. The interrupt service routine will need to clear the global interrupt flag bit and the serviced event, via the interrupt clear register (QCLR), before any other interrupt pulses are generated. You can force an interrupt event by way of the interrupt force register (QFRC), which is useful for test purposes.

3 Registers

Table 2 lists the registers with their memory locations, sizes, and reset values.

Table 2. EQEP Registers

| Offset | Acronym | Register Description | Size(×16)/ #shadow | Section |
|--------|----------|---|--------------------|------------------------------|
| 0h | QPOSCNT | eQEP Position Counter Register | 2/0 | Section 3.1 |
| 4h | QPOSINIT | eQEP Position Counter Initialization Register | 2/0 | Section 3.2 |
| 8h | QPOSMAX | eQEP Maximum Position Count Register | 2/0 | Section 3.3 |
| Ch | QPOSCMP | eQEP Position-Compare Register | 2/1 | Section 3.4 |
| 10h | QPOSILAT | eQEP Index Position Latch Register | 2/0 | Section 3.5 |
| 14h | QPOSSLAT | eQEP Strobe Position Latch Register | 2/0 | Section 3.6 |
| 18h | QPOSLAT | eQEP Position Counter Latch Register | 2/0 | Section 3.7 |
| 1Ch | QUTMR | eQEP Unit Timer Register | 2/0 | Section 3.8 |
| 20h | QUPRD | eQEP Unit Period Register | 2/0 | Section 3.9 |
| 24h | QWDTMR | eQEP Watchdog Timer Register | 1/0 | Section 3.10 |
| 26h | QWDPRD | eQEP Watchdog Period Register | 1/0 | Section 3.11 |
| 28h | QDECCTL | eQEP Decoder Control Register | 1/0 | Section 3.12 |
| 2Ah | QEPCTL | eQEP Control Register | 1/0 | Section 3.13 |
| 2Ch | QCAPCTL | eQEP Capture Control Register | 1/0 | Section 3.14 |
| 2Eh | QPOSCTL | eQEP Position-Compare Control Register | 1/0 | Section 3.15 |
| 30h | QEINT | eQEP Interrupt Enable Register | 1/0 | Section 3.16 |
| 32h | QFLG | eQEP Interrupt Flag Register | 1/0 | Section 3.17 |
| 34h | QCLR | eQEP Interrupt Clear Register | 1/0 | Section 3.18 |
| 36h | QFRC | eQEP Interrupt Force Register | 1/0 | Section 3.19 |
| 38h | QEPSTS | eQEP Status Register | 1/0 | Section 3.20 |
| 3Ah | QCTMR | eQEP Capture Timer Register | 1/0 | Section 3.21 |
| 3Ch | QCPRD | eQEP Capture Period Register | 1/0 | Section 3.22 |
| 3Eh | QCTMRLAT | eQEP Capture Timer Latch Register | 1/0 | Section 3.23 |
| 40h | QCPRDLAT | eQEP Capture Period Latch Register | 1/0 | Section 3.24 |
| 5Ch | REVID | eQEP Revision ID Register | 2/0 | Section 3.25 |

3.1 eQEP Position Counter Register (QPOSCNT)

Figure 21. eQEP Position Counter Register (QPOSCNT)

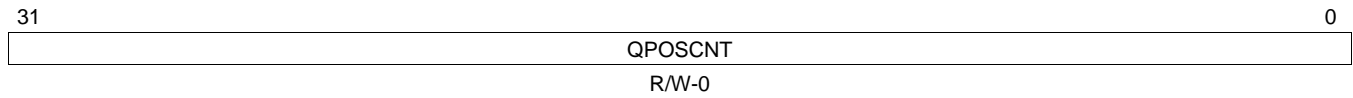

LEGEND: R/W = Read/Write; R = Read only; -n = value after reset

Table 3. eQEP Position Counter Register (QPOSCNT) Field Descriptions

| Bits | Name | Value | Description |
|------|---------|--------------|--|
| 31-0 | QPOSCNT | 0-FFFF FFFFh | This 32-bit position counter register counts up/down on every eQEP pulse based on direction input. This counter acts as a position integrator whose count value is proportional to position from a give reference point. |

3.2 eQEP Position Counter Initialization Register (QPOSINIT)

Figure 22. eQEP Position Counter Initialization Register (QPOSINIT)

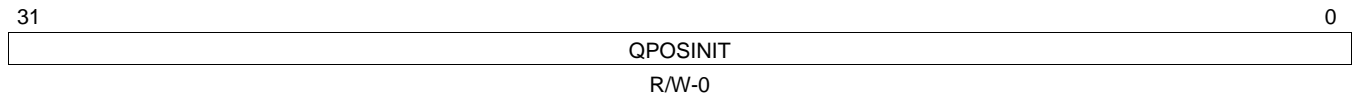

LEGEND: R/W = Read/Write; R = Read only; -n = value after reset

Table 4. eQEP Position Counter Initialization Register (QPOSINIT) Field Descriptions

| Bits | Name | Value | Description |
|------|----------|--------------|--|
| 31-0 | QPOSINIT | 0-FFFF FFFFh | This register contains the position value that is used to initialize the position counter based on external strobe or index event. The position counter can be initialized through software. |

3.3 eQEP Maximum Position Count Register (QPOSMAX)

Figure 23. eQEP Maximum Position Count Register (QPOSMAX)

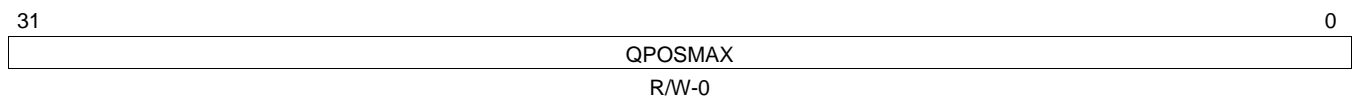

LEGEND: R/W = Read/Write; R = Read only; -n = value after reset

Table 5. eQEP Maximum Position Count Register (QPOSMAX) Field Descriptions

| Bits | Name | Value | Description |
|------|---------|--------------|--|
| 31-0 | QPOSMAX | 0-FFFF FFFFh | This register contains the maximum position counter value. |

3.4 eQEP Position-Compare Register (QPOSCMP)

Figure 24. eQEP Position-Compare Register (QPOSCMP)

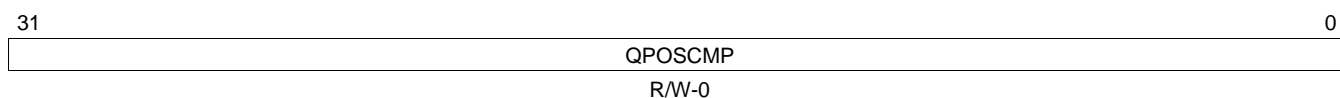

LEGEND: R/W = Read/Write; R = Read only; -n = value after reset

Table 6. eQEP Position-Compare Register (QPOSCMP) Field Descriptions

| Bits | Name | Value | Description |
|------|---------|--------------|--|
| 31-0 | QPOSCMP | 0-FFFF FFFFh | The position-compare value in this register is compared with the position counter (QPOSCNT) to generate sync output and/or interrupt on compare match. |

3.5 eQEP Index Position Latch Register (QPOSILAT)

Figure 25. eQEP Index Position Latch Register (QPOSILAT)

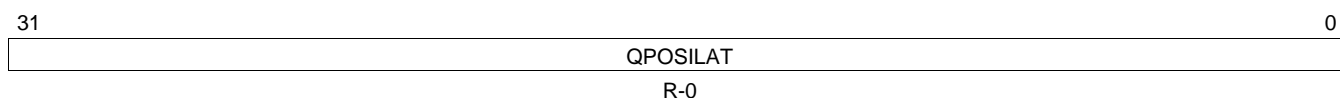

LEGEND: R/W = Read/Write; R = Read only; -n = value after reset

Table 7. eQEP Index Position Latch Register (QPOSILAT) Field Descriptions

| Bits | Name | Value | Description |
|------|----------|--------------|--|
| 31-0 | QPOSILAT | 0-FFFF FFFFh | The position-counter value is latched into this register on an index event as defined by the QEPCTL[IEL] bits. |

3.6 eQEP Strobe Position Latch Register (QPOSSLAT)

Figure 26. eQEP Strobe Position Latch Register (QPOSSLAT)

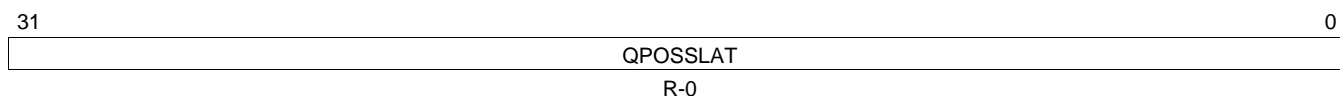

LEGEND: R/W = Read/Write; R = Read only; -n = value after reset

Table 8. eQEP Strobe Position Latch Register (QPOSSLAT) Field Descriptions

| Bits | Name | Value | Description |
|------|----------|--------------|--|
| 31-0 | QPOSSLAT | 0-FFFF FFFFh | The position-counter value is latched into this register on strobe event as defined by the QEPCTL[SEL] bits. |

3.7 eQEP Position Counter Latch Register (QOSLAT)

Figure 27. eQEP Position Counter Latch Register (QOSLAT)

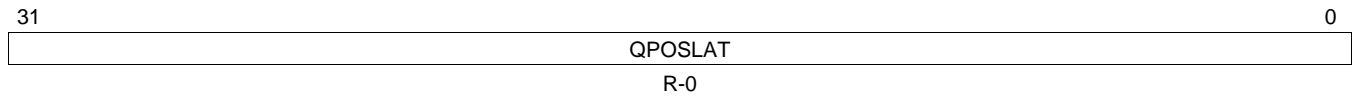

LEGEND: R/W = Read/Write; R = Read only; -n = value after reset

Table 9. eQEP Position Counter Latch Register (QOSLAT) Field Descriptions

| Bits | Name | Value | Description |
|------|--------|--------------|--|
| 31-0 | QOSLAT | 0-FFFF FFFFh | The position-counter value is latched into this register on unit time out event. |

3.8 eQEP Unit Timer Register (QUTMR)

Figure 28. eQEP Unit Timer Register (QUTMR)

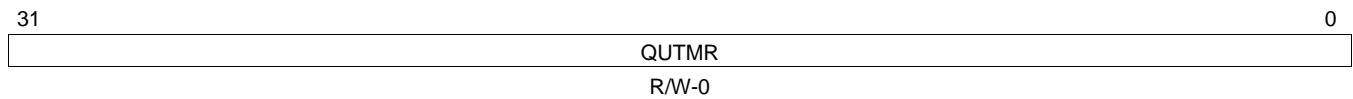

LEGEND: R/W = Read/Write; R = Read only; -n = value after reset

Table 10. eQEP Unit Timer Register (QUTMR) Field Descriptions

| Bits | Name | Value | Description |
|------|-------|--------------|--|
| 31-0 | QUTMR | 0-FFFF FFFFh | This register acts as time base for unit time event generation. When this timer value matches with unit time period value, unit time event is generated. |

3.9 eQEP Unit Period Register (QUPRD)

Figure 29. eQEP Unit Period Register (QUPRD)

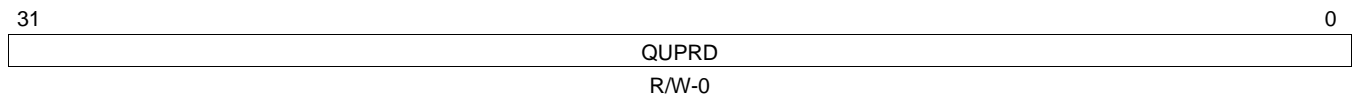

LEGEND: R/W = Read/Write; R = Read only; -n = value after reset

Table 11. eQEP Unit Period Register (QUPRD) Field Descriptions

| Bits | Name | Value | Description |
|------|-------|--------------|--|
| 31-0 | QUPRD | 0-FFFF FFFFh | This register contains the period count for unit timer to generate periodic unit time events to latch the eQEP position information at periodic interval and optionally to generate interrupt. |

3.10 eQEP Watchdog Timer Register (QWDTMR)

Figure 30. eQEP Watchdog Timer Register (QWDTMR)

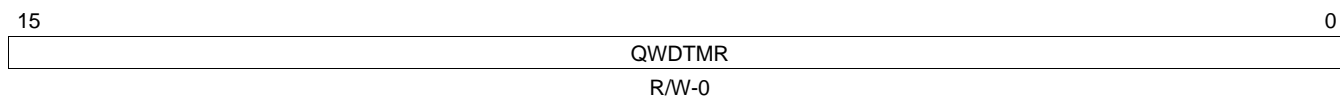

LEGEND: R/W = Read/Write; R = Read only; -n = value after reset

Table 12. eQEP Watchdog Timer Register (QWDTMR) Field Descriptions

| Bits | Name | Value | Description |
|------|--------|--------------|---|
| 15-0 | QWDTMR | 0-FFFF FFFFh | This register acts as time base for watch dog to detect motor stalls. When this timer value matches with watch dog period value, watch dog timeout interrupt is generated. This register is reset upon edge transition in quadrature-clock indicating the motion. |

3.11 eQEP Watchdog Period Register (QWDPRD)

Figure 31. eQEP Watchdog Period Register (QWDPRD)

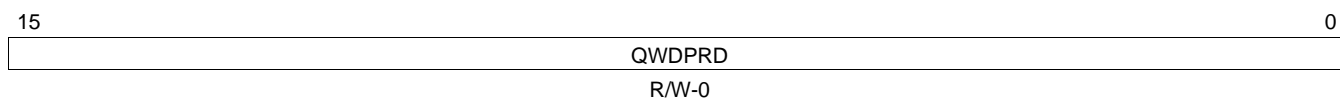

LEGEND: R/W = Read/Write; R = Read only; -n = value after reset

Table 13. eQEP Watchdog Period Register (QWDPRD) Field Description

| Bits | Name | Value | Description |
|------|--------|---------|--|
| 15-0 | QWDPRD | 0-FFFFh | This register contains the time-out count for the eQEP peripheral watch dog timer. When the watchdog timer value matches the watchdog period value, a watchdog timeout interrupt is generated. |

3.12 QEP Decoder Control Register (QDECCTL)

Figure 32. QEP Decoder Control Register (QDECCTL)

| | | | | | | | |
|-------|-------|-------|----------|-------|-------|-------|-------|
| 15 | 14 | 13 | 12 | 11 | 10 | 9 | 8 |
| QSRC | | SOEN | SPSEL | XCR | SWAP | IGATE | QAP |
| R/W-0 | | R/W-0 | R/W-0 | R/W-0 | R/W-0 | R/W-0 | R/W-0 |
| 7 | 6 | 5 | 4 | | | | 0 |
| QBP | QIP | QSP | Reserved | | | | |
| R/W-0 | R/W-0 | R/W-0 | R-0 | | | | |

LEGEND: R/W = Read/Write; R = Read only; -n = value after reset

Table 14. eQEP Decoder Control Register (QDECCTL) Field Descriptions

| Bits | Name | Value | Description |
|-------|----------|--------|---|
| 15-14 | QSRC | 0-3h | Position-counter source selection 0 Quadrature count mode (QCLK = iCLK, QDIR = iDIR) 1h Direction-count mode (QCLK = xCLK, QDIR = xDIR) 2h UP count mode for frequency measurement (QCLK = xCLK, QDIR = 1) 3h DOWN count mode for frequency measurement (QCLK = xCLK, QDIR = 0) |
| 13 | SOEN | 0 1 | Sync output-enable 0 Disable position-compare sync output 1 Enable position-compare sync output |
| 12 | SPSEL | 0 1 | Sync output pin selection 0 Index pin is used for sync output 1 Strobe pin is used for sync output |
| 11 | XCR | 0 1 | External clock rate 0 2× resolution: Count the rising/falling edge 1 1× resolution: Count the rising edge only |
| 10 | SWAP | 0 1 | Swap quadrature clock inputs. This swaps the input to the quadrature decoder, reversing the counting direction. 0 Quadrature-clock inputs are not swapped 1 Quadrature-clock inputs are swapped |
| 9 | IGATE | 0 1 | Index pulse gating option 0 Disable gating of Index pulse 1 Gate the index pin with strobe |
| 8 | QAP | 0 1 | QEPA input polarity 0 No effect 1 Negates QEPA input |
| 7 | QBP | 0 1 | QEPB input polarity 0 No effect 1 Negates QEPB input |
| 6 | QIP | 0 1 | QEPI input polarity 0 No effect 1 Negates QEPI input |
| 5 | QSP | 0 1 | QEPS input polarity 0 No effect 1 Negates QEPS input |
| 4-0 | Reserved | 0 | Always write as 0 |

3.13 eQEP Control Register (QEPCCTL)

Figure 33. eQEP Control Register (QEPCCTL)

| | | | | | | | |
|------------|-------|-------|----|-------|-------|-------|-------|
| 15 | 14 | 13 | 12 | 11 | 10 | 9 | 8 |
| FREE, SOFT | | PCRM | | SEI | | IEI | |
| R/W-0 | | R/W-0 | | R/W-0 | | R/W-0 | |
| 7 | 6 | 5 | 4 | 3 | 2 | 1 | 0 |
| SWI | SEL | IEL | | PHEN | QCLM | UTE | WDE |
| R/W-0 | R/W-0 | R/W-0 | | R/W-0 | R/W-0 | R/W-0 | R/W-0 |

LEGEND: R/W = Read/Write; -n = value after reset

Table 15. eQEP Control Register (QEPCCTL) Field Descriptions

| Bits | Name | Value | Description |
|-------|------------|-------|---|
| 15-14 | FREE, SOFT | 0-3h | Emulation Control Bits QPOSCNT behavior: |
| | | 0 | Position counter stops immediately on emulation suspend. |
| | | 1h | Position counter continues to count until the rollover. |
| | | 2h-3h | Position counter is unaffected by emulation suspend. |
| | | 0 | QWDTMR behavior: Watchdog counter stops immediately. |
| | | 1 | Watchdog counter counts until WD period match roll over. |
| | | 2h-3h | Watchdog counter is unaffected by emulation suspend. |
| | | 0 | QUTMR behavior: Unit timer stops immediately. |
| | | 1h | Unit timer counts until period rollover. |
| | | 2h-3h | Unit timer is unaffected by emulation suspend. |
| | | 0 | QCTMR behavior: Capture Timer stops immediately. |
| | | 1h | Capture Timer counts until next unit period event. |
| | | 2h-3h | Capture Timer is unaffected by emulation suspend. |
| | | 0-3h | Position counter reset mode |
| | | 0 | Position counter reset on an index event |
| | | 1h | Position counter reset on the maximum position |
| | | 2h | Position counter reset on the first index event |
| | | 3h | Position counter reset on a unit time event |
| | | 0-3h | Strobe event initialization of position counter |
| | | 0 | Does nothing (action disabled) |
| | | 1h | Does nothing (action disabled) |
| | | 2h | Initializes the position counter on rising edge of the QEPS signal |
| | | 3h | Clockwise Direction: Initializes the position counter on the rising edge of QEPS strobe Counter Clockwise Direction: Initializes the position counter on the falling edge of QEPS strobe |
| | | 0-3h | Index event initialization of position counter |
| | | 0 | Do nothing (action disabled) |
| | | 1h | Do nothing (action disabled) |
| | | 2h | Initializes the position counter on the rising edge of the QEPI signal (QPOSCNT = QPOSINIT) |
| | | 3h | Initializes the position counter on the falling edge of QEPI signal (QPOSCNT = QPOSINIT) |

Table 15. eQEP Control Register (QEPCTL) Field Descriptions (continued)

| Bits | Name | Value | Description |
|------|------|-----------------------------|--|
| 7 | SWI | 0 1 | Software initialization of position counter Do nothing (action disabled) Initialize position counter, this bit is cleared automatically |
| 6 | SEL | 0 1 | Strobe event latch of position counter The position counter is latched on the rising edge of QEPS strobe (QPOSSLAT = POSCNT). Latching on the falling edge can be done by inverting the strobe input using the QSP bit in the QDECCTL register. Clockwise Direction: Position counter is latched on rising edge of QEPS strobe Counter Clockwise Direction: Position counter is latched on falling edge of QEPS strobe |
| 5-4 | IEL | 0-3h 0 1h 2h 3h | Index event latch of position counter (software index marker) Reserved Latches position counter on rising edge of the index signal Latches position counter on falling edge of the index signal Software index marker. Latches the position counter and quadrature direction flag on index event marker. The position counter is latched to the QPOSILAT register and the direction flag is latched in the QEPSTS[QDLF] bit. This mode is useful for software index marking. |
| 3 | PHEN | 0 1 | Quadrature position counter enable/software reset Reset the eQEP peripheral internal operating flags/read-only registers. Control/configuration registers are not disturbed by a software reset. eQEP position counter is enabled |
| 2 | QCLM | 0 1 | eQEP capture latch mode Latch on position counter read by CPU. Capture timer and capture period values are latched into QCTMRLAT and QCPRDLAT registers when CPU reads the QPOSCNT register. Latch on unit time out. Position counter, capture timer and capture period values are latched into QPOSILAT, QCTMRLAT and QCPRDLAT registers on unit time out. |
| 1 | UTE | 0 1 | eQEP unit timer enable Disable eQEP unit timer Enable unit timer |
| 0 | WDE | 0 1 | eQEP watchdog enable Disable the eQEP watchdog timer Enable the eQEP watchdog timer |

3.14 eQEP Capture Control Register (QCAPCTL)

Figure 34. eQEP Capture Control Register (QCAPCTL)

| | | |
|----------|----------|-------|
| 15 | 14 | 8 |
| CEN | Reserved | |
| R/W-0 | R-0 | |
| 7 | 6 | 4 |
| Reserved | CCPS | UPPS |
| R-0 | R/W-0 | R/W-0 |

LEGEND: R/W = Read/Write; R = Read only; -n = value after reset

Table 16. eQEP Capture Control Register (QCAPCTL) Field Descriptions

| Bits | Name | Value | Description |
|------|----------|--|--|
| 15 | CEN | 0 1 | Enable eQEP capture eQEP capture unit is disabled eQEP capture unit is enabled |
| 14-7 | Reserved | 0 | Always write as 0 |
| 6-4 | CCPS | 0-7h 0 1h 2h 3h 4h 5h 6h 7h | eQEP capture timer clock prescaler CAPCLK = SYSCLKOUT/1 CAPCLK = SYSCLKOUT/2 CAPCLK = SYSCLKOUT/4 CAPCLK = SYSCLKOUT/8 CAPCLK = SYSCLKOUT/16 CAPCLK = SYSCLKOUT/32 CAPCLK = SYSCLKOUT/64 CAPCLK = SYSCLKOUT/128 |
| 3-0 | UPPS | 0-Fh 0 1h 2h 3h 4h 5h 6h 7h 8h 9h Ah Bh Ch-Fh | Unit position event prescaler UPEVNT = QCLK/1 UPEVNT = QCLK/2 UPEVNT = QCLK/4 UPEVNT = QCLK/8 UPEVNT = QCLK/16 UPEVNT = QCLK/32 UPEVNT = QCLK/64 UPEVNT = QCLK/128 UPEVNT = QCLK/256 UPEVNT = QCLK/512 UPEVNT = QCLK/1024 UPEVNT = QCLK/2048 Reserved |

3.15 eQEP Position-Compare Control Register (QPOSCTL)

Figure 35. eQEP Position-Compare Control Register (QPOSCTL)

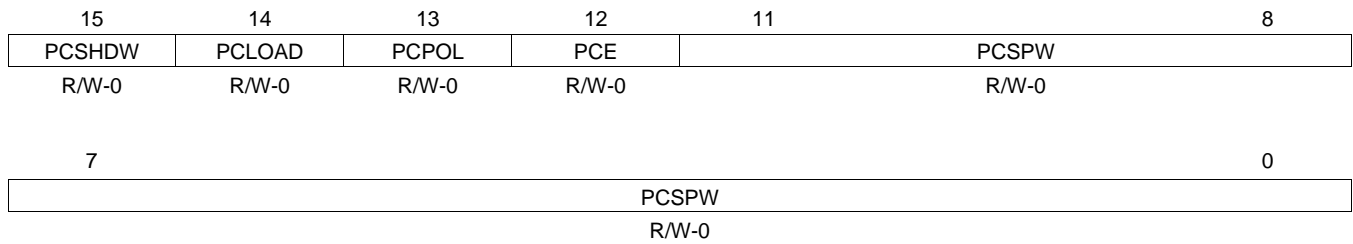

LEGEND: R/W = Read/Write; R = Read only; -n = value after reset

Table 17. eQEP Position-Compare Control Register (QPOSCTL) Field Descriptions

| Bit | Name | Value | Description |
|------|--------|------------------------------|--|
| 15 | PCSHDW | 0 1 | Position-compare shadow enable Shadow disabled, load Immediate Shadow enabled |
| 14 | PCLOAD | 0 1 | Position-compare shadow load mode Load on QPOSCNT = 0 Load when QPOSCNT = QPOSCMP |
| 13 | PCPOL | 0 1 | Polarity of sync output Active HIGH pulse output Active LOW pulse output |
| 12 | PCE | 0 1 | Position-compare enable/disable Disable position compare unit Enable position compare unit |
| 11-0 | PCSPW | 0-FFFh 0 1h 2h-FFFh | Select-position-compare sync output pulse width $1 \times 4 \times \text{SYSCLKOUT}$ cycles $2 \times 4 \times \text{SYSCLKOUT}$ cycles $3 \times 4 \times \text{SYSCLKOUT}$ cycles to $4096 \times 4 \times \text{SYSCLKOUT}$ cycles |

3.16 eQEP Interrupt Enable Register (QEINT)

Figure 36. eQEP Interrupt Enable Register (QEINT)

| | | | | | | | | | |
|----------|--|-------|-------|-------|-------|-------|-------|----------|-------|
| 15 | | | | 12 | | 11 | 10 | 9 | 8 |
| Reserved | | | | UTO | | IEL | SEL | PCM | |
| R-0 | | | | R/W-0 | | R/W-0 | R/W-0 | R/W-0 | R/W-0 |
| 7 | | 6 | 5 | 4 | 3 | 2 | 1 | 0 | |
| PCR | | PCO | PCU | WTO | QDC | PHE | PCE | Reserved | |
| R/W-0 | | R/W-0 | R/W-0 | R/W-0 | R/W-0 | R/W-0 | R/W-0 | R-0 | |

LEGEND: R/W = Read/Write; R = Read only; -n = value after reset

Table 18. eQEP Interrupt Enable Register (QEINT) Field Descriptions

| Bits | Name | Value | Description |
|-------|----------|-------|---|
| 15-12 | Reserved | 0 | Always write as 0 |
| 11 | UTO | 0 | Unit time out interrupt enable Interrupt is disabled |
| | | 1 | Interrupt is enabled |
| 10 | IEL | 0 | Index event latch interrupt enable Interrupt is disabled |
| | | 1 | Interrupt is enabled |
| 9 | SEL | 0 | Strobe event latch interrupt enable Interrupt is disabled |
| | | 1 | Interrupt is enabled |
| 8 | PCM | 0 | Position-compare match interrupt enable Interrupt is disabled |
| | | 1 | Interrupt is enabled |
| 7 | PCR | 0 | Position-compare ready interrupt enable Interrupt is disabled |
| | | 1 | Interrupt is enabled |
| 6 | PCO | 0 | Position counter overflow interrupt enable Interrupt is disabled |
| | | 1 | Interrupt is enabled |
| 5 | PCU | 0 | Position counter underflow interrupt enable Interrupt is disabled |
| | | 1 | Interrupt is enabled |
| 4 | WTO | 0 | Watchdog time out interrupt enable Interrupt is disabled |
| | | 1 | Interrupt is enabled |
| 3 | QDC | 0 | Quadrature direction change interrupt enable Interrupt is disabled |
| | | 1 | Interrupt is enabled |
| 2 | PHE | 0 | Quadrature phase error interrupt enable Interrupt is disabled |
| | | 1 | Interrupt is enabled |
| 1 | PCE | 0 | Position counter error interrupt enable Interrupt is disabled |
| | | 1 | Interrupt is enabled |

Table 18. eQEP Interrupt Enable Register (QEINT) Field Descriptions (continued)

| Bits | Name | Value | Description |
|------|----------|-------|-------------|
| 0 | Reserved | 0 | Reserved |

3.17 eQEP Interrupt Flag Register (QFLG)

Figure 37. eQEP Interrupt Flag Register (QFLG)

| | | | | | | | | | |
|----------|-----|-----|-----|-----|-----|-----|-----|-----|---|
| 15 | | | | | 12 | 11 | 10 | 9 | 8 |
| Reserved | | | | | UTO | IEL | SEL | PCM | |
| R-0 | | | | | R-0 | R-0 | R-0 | R-0 | |
| | | | | | | | | | |
| 7 | 6 | 5 | 4 | 3 | 2 | 1 | 0 | | |
| PCR | PCO | PCU | WTO | QDC | PHE | PCE | INT | | |
| R-0 | R-0 | R-0 | R-0 | R-0 | R-0 | R-0 | R-0 | | |

LEGEND: R = Read only; -n = value after reset

Table 19. eQEP Interrupt Flag Register (QFLG) Field Descriptions

| Bits | Name | Value | Description |
|-------|----------|-------|---|
| 15-12 | Reserved | 0 | Always write as 0 |
| 11 | UTO | 0 | No interrupt generated |
| | | 1 | Set by eQEP unit timer period match |
| 10 | IEL | 0 | No interrupt generated |
| | | 1 | This bit is set after latching the QPOSCNT to QPOSILAT |
| 9 | SEL | 0 | No interrupt generated |
| | | 1 | This bit is set after latching the QPOSCNT to QPOSSLAT |
| 8 | PCM | 0 | No interrupt generated |
| | | 1 | This bit is set on position-compare match |
| 7 | PCR | 0 | No interrupt generated |
| | | 1 | This bit is set after transferring the shadow register value to the active position compare register. |
| 6 | PCO | 0 | No interrupt generated |
| | | 1 | This bit is set on position counter overflow. |
| 5 | PCU | 0 | No interrupt generated |
| | | 1 | This bit is set on position counter underflow. |
| 4 | WTO | 0 | No interrupt generated |
| | | 1 | Set by watch dog timeout |
| 3 | QDC | 0 | No interrupt generated |
| | | 1 | This bit is set during change of direction |

Table 19. eQEP Interrupt Flag Register (QLFG) Field Descriptions (continued)

| Bits | Name | Value | Description |
|------|------|-------|---|
| 2 | PHE | 0 | Quadrature phase error interrupt flag No interrupt generated |
| | | 1 | Set on simultaneous transition of QEPA and QEPB |
| 1 | PCE | 0 | Position counter error interrupt flag No interrupt generated |
| | | 1 | Position counter error |
| 0 | INT | 0 | Global interrupt status flag No interrupt generated |
| | | 1 | Interrupt was generated |

3.18 eQEP Interrupt Clear Register (QCLR)

Figure 38. eQEP Interrupt Clear Register (QCLR)

| | | | | | | | | | |
|----------|-------|-------|-------|-------|-------|-------|-------|-------|---|
| 15 | | | | | 12 | 11 | 10 | 9 | 8 |
| Reserved | | | | | UTO | IEL | SEL | PCM | |
| R-0 | | | | | R/W-0 | R/W-0 | R/W-0 | R/W-0 | |
| | | | | | | | | | |
| 7 | 6 | 5 | 4 | 3 | 2 | 1 | 0 | | |
| PCR | PCO | PCU | WTO | QDC | PHE | PCE | INT | | |
| R/W-0 | R/W-0 | R/W-0 | R/W-0 | R/W-0 | R/W-0 | R/W-0 | R/W-0 | | |

LEGEND: R/W = Read/Write; R = Read only; -n = value after reset

Table 20. eQEP Interrupt Clear Register (QCLR) Field Descriptions

| Bit | Field | Value | Description |
|-------|----------|-------|---|
| 15-12 | Reserved | 0 | Always write as 0s |
| 11 | UTO | 0 | Clear unit time out interrupt flag No effect |
| | | 1 | Clears the interrupt flag |
| 10 | IEL | 0 | Clear index event latch interrupt flag No effect |
| | | 1 | Clears the interrupt flag |
| 9 | SEL | 0 | Clear strobe event latch interrupt flag No effect |
| | | 1 | Clears the interrupt flag |
| 8 | PCM | 0 | Clear eQEP compare match event interrupt flag No effect |
| | | 1 | Clears the interrupt flag |
| 7 | PCR | 0 | Clear position-compare ready interrupt flag No effect |
| | | 1 | Clears the interrupt flag |
| 6 | PCO | 0 | Clear position counter overflow interrupt flag No effect |
| | | 1 | Clears the interrupt flag |

Table 20. eQEP Interrupt Clear Register (QCLR) Field Descriptions (continued)

| Bit | Field | Value | Description |
|-----|-----------|-------|---|
| 5 | PCU | | Clear position counter underflow interrupt flag |
| | | 0 | No effect |
| | | 1 | Clears the interrupt flag |
| | | 4 | WTO |
| 0 | No effect | | |
| | | 1 | Clears the interrupt flag |
| | | 3 | QDC |
| 0 | No effect | | |
| | | 1 | Clears the interrupt flag |
| | | 2 | PHE |
| 0 | No effect | | |
| | | 1 | Clears the interrupt flag |
| | | 1 | PCE |
| 0 | No effect | | |
| | | 1 | Clears the interrupt flag |
| | | 0 | INT |
| 0 | No effect | | |
| | | 1 | Clears the interrupt flag and enables further interrupts to be generated if an event flags is set to 1. |

3.19 eQEP Interrupt Force Register (QFRC)

Figure 39. eQEP Interrupt Force Register (QFRC)

| | | | | | | | | |
|----------|-------|----------|-------|-------|-------|-------|----------|-------|
| 15 | | 12 | | | 11 | 10 | 9 | 8 |
| Reserved | | Reserved | | | UTO | IEL | SEL | PCM |
| R-0 | | R-0 | | | R/W-0 | R/W-0 | R/W-0 | R/W-0 |
| 7 | | 6 | 5 | 4 | 3 | 2 | 1 | 0 |
| PCR | PCO | PCU | WTO | QDC | PHE | PCE | Reserved | |
| R/W-0 | R/W-0 | R/W-0 | R/W-0 | R/W-0 | R/W-0 | R/W-0 | R/W-0 | R-0 |

LEGEND: R/W = Read/Write; R = Read only; -n = value after reset

Table 21. eQEP Interrupt Force Register (QFRC) Field Descriptions

| Bit | Field | Value | Description |
|-------|----------|-------|---|
| 15-12 | Reserved | 0 | Always write as 0s |
| 11 | UTO | 0 | Force unit time out interrupt |
| | | 1 | No effect |
| 10 | IEL | 0 | Force the interrupt |
| | | 1 | No effect |
| 9 | SEL | 0 | Force index event latch interrupt |
| | | 1 | No effect |
| 8 | PCM | 0 | Force strobe event latch interrupt |
| | | 1 | No effect |
| 7 | PCR | 0 | Force position-compare match interrupt |
| | | 1 | No effect |
| 6 | PCO | 0 | Force position-compare ready interrupt |
| | | 1 | No effect |
| 5 | PCU | 0 | Force position counter overflow interrupt |
| | | 1 | No effect |
| 4 | WTO | 0 | Force position counter underflow interrupt |
| | | 1 | No effect |
| 3 | QDC | 0 | Force watchdog time out interrupt |
| | | 1 | No effect |
| 2 | PHE | 0 | Force quadrature direction change interrupt |
| | | 1 | No effect |
| 1 | PCE | 0 | Force quadrature phase error interrupt |
| | | 1 | No effect |
| 0 | Reserved | 0 | Force position counter error interrupt |
| | | | Always write as 0 |

3.20 eQEP Status Register (QEPSTS)

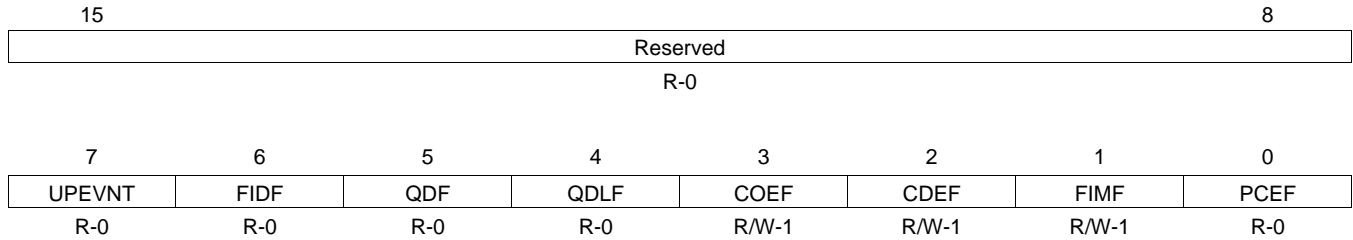
Figure 40. eQEP Status Register (QEPSTS)

LEGEND: R/W = Read/Write; R = Read only; -n = value after reset

Table 22. eQEP Status Register (QEPSTS) Field Descriptions

| Bit | Field | Value | Description |
|------|----------|--------|--|
| 15-8 | Reserved | 0 | Always write as 0 |
| 7 | UPEVNT | 0 1 | Unit position event flag No unit position event detected Unit position event detected. Write 1 to clear. |
| 6 | FDF | 0 1 | Direction on the first index marker. Status of the direction is latched on the first index event marker. Counter-clockwise rotation (or reverse movement) on the first index event Clockwise rotation (or forward movement) on the first index event |
| 5 | QDF | 0 1 | Quadrature direction flag Counter-clockwise rotation (or reverse movement) Clockwise rotation (or forward movement) |
| 4 | QDLF | 0 1 | eQEP direction latch flag. Status of direction is latched on every index event marker. Counter-clockwise rotation (or reverse movement) on index event marker Clockwise rotation (or forward movement) on index event marker |
| 3 | COEF | 0 1 | Capture overflow error flag Sticky bit, cleared by writing 1 Overflow occurred in eQEP Capture timer (QEPCTMR) |
| 2 | CDEF | 0 1 | Capture direction error flag Sticky bit, cleared by writing 1 Direction change occurred between the capture position event. |
| 1 | FIMF | 0 1 | First index marker flag Sticky bit, cleared by writing 1 Set by first occurrence of index pulse |
| 0 | PCEF | 0 1 | Position counter error flag. This bit is not sticky and it is updated for every index event. No error occurred during the last index transition. Position counter error |

3.21 eQEP Capture Timer Register (QCTMR)

Figure 41. eQEP Capture Timer Register (QCTMR)

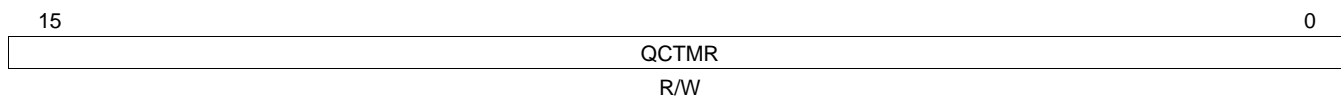

LEGEND: R/W = Read/Write; R = Read only; -n = value after reset

Table 23. eQEP Capture Time Register (QCTMR) Field Descriptions

| Bits | Name | Value | Description |
|------|-------|---------|---|
| 15-0 | QCTMR | 0-FFFFh | This register provides time base for edge capture unit. |

3.22 eQEP Capture Period Register (QCPRD)

Figure 42. eQEP Capture Period Register (QCPRD)

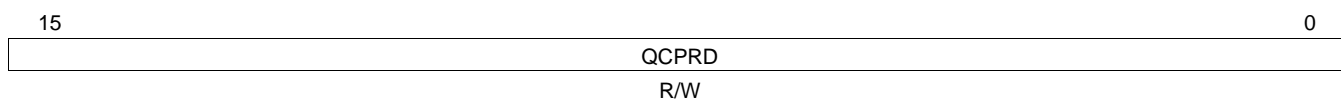

LEGEND: R/W = Read/Write; R = Read only; -n = value after reset

Table 24. eQEP Capture Period Register (QCPRD) Field Descriptions

| Bits | Name | Value | Description |
|------|-------|---------|---|
| 15-0 | QCPRD | 0-FFFFh | This register holds the period count value between the last successive eQEP position events |

3.23 eQEP Capture Timer Latch Register (QCTMRLAT)

Figure 43. eQEP Capture Timer Latch Register (QCTMRLAT)

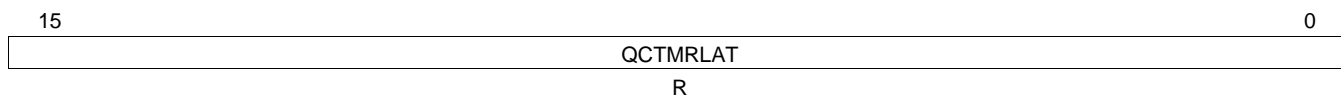

LEGEND: R/W = Read/Write; R = Read only; -n = value after reset

Table 25. eQEP Capture Timer Latch Register (QCTMRLAT) Field Descriptions

| Bits | Name | Value | Description |
|------|----------|---------|---|
| 15-0 | QCTMRLAT | 0-FFFFh | The eQEP capture timer value can be latched into this register on two events viz., unit timeout event, reading the eQEP position counter. |

3.24 eQEP Capture Period Latch Register (QCPRDLAT)

Figure 44. eQEP Capture Period Latch Register (QCPRDLAT)

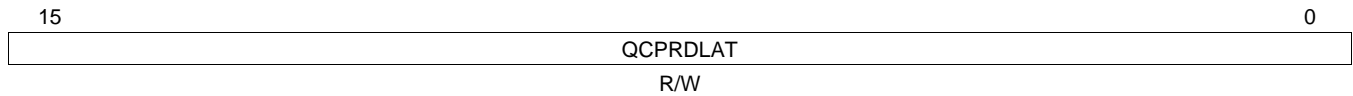

LEGEND: R/W = Read/Write; R = Read only; -n = value after reset

Table 26. eQEP Capture Period Latch Register (QCPRDLAT) Field Descriptions

| Bits | Name | Value | Description |
|------|----------|---------|--|
| 15-0 | QCPRDLAT | 0-FFFFh | eQEP capture period value can be latched into this register on two events viz., unit timeout event, reading the eQEP position counter. |

3.25 eQEP Revision ID Register (REVID)

Figure 45. eQEP Revision ID Register (REVID)

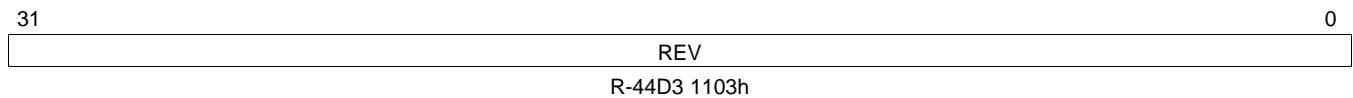

LEGEND: R = Read only; -n = value after reset

Table 27. eQEP Revision ID Register (REVID) Field Descriptions

| Bits | Name | Value | Description |
|------|------|------------|------------------|
| 31-0 | REV | 44D3 1103h | eQEP revision ID |

Appendix A Revision History

[Table A-1](#) lists the changes made since the previous version of this document.

Table A-1. Document Revision History

| Reference | Additions/Modifications/Deletions |
|-----------------------------|--|
| Global | Changed PIE to Interrupt Controller. |
| Figure 4 | Changed figure. |
| Section 2.8 | Changed fourth sentence in second paragraph. |

IMPORTANT NOTICE

Texas Instruments Incorporated and its subsidiaries (TI) reserve the right to make corrections, modifications, enhancements, improvements, and other changes to its products and services at any time and to discontinue any product or service without notice. Customers should obtain the latest relevant information before placing orders and should verify that such information is current and complete. All products are sold subject to TI's terms and conditions of sale supplied at the time of order acknowledgment.

TI warrants performance of its hardware products to the specifications applicable at the time of sale in accordance with TI's standard warranty. Testing and other quality control techniques are used to the extent TI deems necessary to support this warranty. Except where mandated by government requirements, testing of all parameters of each product is not necessarily performed.

TI assumes no liability for applications assistance or customer product design. Customers are responsible for their products and applications using TI components. To minimize the risks associated with customer products and applications, customers should provide adequate design and operating safeguards.

TI does not warrant or represent that any license, either express or implied, is granted under any TI patent right, copyright, mask work right, or other TI intellectual property right relating to any combination, machine, or process in which TI products or services are used. Information published by TI regarding third-party products or services does not constitute a license from TI to use such products or services or a warranty or endorsement thereof. Use of such information may require a license from a third party under the patents or other intellectual property of the third party, or a license from TI under the patents or other intellectual property of TI.

Reproduction of TI information in TI data books or data sheets is permissible only if reproduction is without alteration and is accompanied by all associated warranties, conditions, limitations, and notices. Reproduction of this information with alteration is an unfair and deceptive business practice. TI is not responsible or liable for such altered documentation. Information of third parties may be subject to additional restrictions.

Resale of TI products or services with statements different from or beyond the parameters stated by TI for that product or service voids all express and any implied warranties for the associated TI product or service and is an unfair and deceptive business practice. TI is not responsible or liable for any such statements.

TI products are not authorized for use in safety-critical applications (such as life support) where a failure of the TI product would reasonably be expected to cause severe personal injury or death, unless officers of the parties have executed an agreement specifically governing such use. Buyers represent that they have all necessary expertise in the safety and regulatory ramifications of their applications, and acknowledge and agree that they are solely responsible for all legal, regulatory and safety-related requirements concerning their products and any use of TI products in such safety-critical applications, notwithstanding any applications-related information or support that may be provided by TI. Further, Buyers must fully indemnify TI and its representatives against any damages arising out of the use of TI products in such safety-critical applications.

TI products are neither designed nor intended for use in military/aerospace applications or environments unless the TI products are specifically designated by TI as military-grade or "enhanced plastic." Only products designated by TI as military-grade meet military specifications. Buyers acknowledge and agree that any such use of TI products which TI has not designated as military-grade is solely at the Buyer's risk, and that they are solely responsible for compliance with all legal and regulatory requirements in connection with such use.

TI products are neither designed nor intended for use in automotive applications or environments unless the specific TI products are designated by TI as compliant with ISO/TS 16949 requirements. Buyers acknowledge and agree that, if they use any non-designated products in automotive applications, TI will not be responsible for any failure to meet such requirements.

Following are URLs where you can obtain information on other Texas Instruments products and application solutions:

Products

| | |
|-----------------------------|--|
| Amplifiers | amplifier.ti.com |
| Data Converters | dataconverter.ti.com |
| DLP® Products | www.dlp.com |
| DSP | dsp.ti.com |
| Clocks and Timers | www.ti.com/clocks |
| Interface | interface.ti.com |
| Logic | logic.ti.com |
| Power Mgmt | power.ti.com |
| Microcontrollers | microcontroller.ti.com |
| RFID | www.ti-rfid.com |
| RF/IF and ZigBee® Solutions | www.ti.com/lprf |

Applications

| | |
|--------------------|--|
| Audio | www.ti.com/audio |
| Automotive | www.ti.com/automotive |
| Broadband | www.ti.com/broadband |
| Digital Control | www.ti.com/digitalcontrol |
| Medical | www.ti.com/medical |
| Military | www.ti.com/military |
| Optical Networking | www.ti.com/opticalnetwork |
| Security | www.ti.com/security |
| Telephony | www.ti.com/telephony |
| Video & Imaging | www.ti.com/video |
| Wireless | www.ti.com/wireless |

Mailing Address: Texas Instruments, Post Office Box 655303, Dallas, Texas 75265
Copyright © 2009, Texas Instruments Incorporated