

TI Designs: TIDA-01632

Automotive Bluetooth® Low Energy Car Access Satellite Node Reference Design



Description

This design is intended for *Passive Entry Passive Start* (PEPS) car access systems that utilize Bluetooth® Low Energy (BLE) technology to determine the location of a key fob. The design exhibits how a vehicle BLE satellite node can be implemented to calculate the angle of arrival (AoA) from a BLE signal and transmit the AoA data via local interconnect network (LIN) using only a single BLE wireless microcontroller and LIN transceiver. Furthermore, the design demonstrates that accurate AoA information can be calculated using only two dipole antennas reducing the printed circuit board (PCB) solution size.

Resources

TIDA-01632	Design Folder
CC2640R2F-Q1	Product Folder
TLIN1029-Q1	Product Folder
TPS7B8233-Q1	Product Folder
SimpleLink™ Software	Software Development Kit (SDK)

Features

- Measure AoA using BLE with only 2 dipole antennas
- Share BLE connection information, AoA and RSSI information via LIN
- Small 45.72 mm × 76.2 mm (1.9" × 3.0") PCB solution size
- Low-power sleep mode with remote wake over LIN < 25 μ A at 14 V
- DC input voltages from 4.65 V to 40 V and load dump voltages up to 45 V
- Compatible with TI's *Real Time Locationing System* (RTL) software toolbox for triangulation and trilateration of a BLE key fob

Applications

- [Passive Entry Passive Start \(PEPS\)](#)
- [Remote Keyless Entry \(RKE\)](#)



ASK Our E2E™ Experts

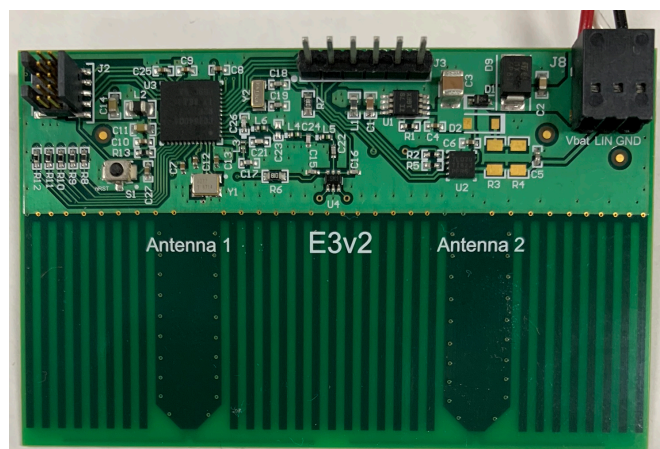
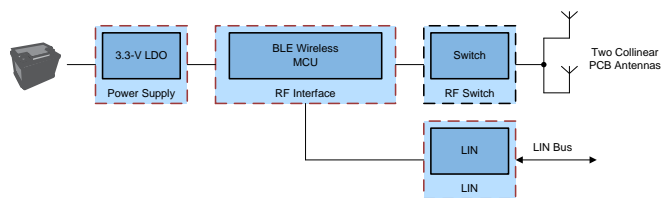

An IMPORTANT NOTICE at the end of this TI reference design addresses authorized use, intellectual property matters and other important disclaimers and information.

1 System Description

This automotive BLE car access satellite node reference design is targeted for PEPS car access systems that use angle of arrival (AoA) measurements from the signal of a BLE keyfob to help determine the location of the key around or inside the vehicle. These satellite nodes must be small enough to place around the outside of the vehicle, such as the B pillar or bumper, and yet also implement multiple antennas on the same PCB to accurately determine the AoA of a signal, thus creating a focus on PCB solution size. This design resolves the issue by using only two dipole antennas with a total PCB solution size (antennas + semiconductor devices) of 45.72 mm × 76.2 mm (1.9" × 3.0"). Furthermore, AoA data is accurately calculated and then transmitted via LIN using only a CC2640R2F-Q1 BLE MCU and TLIN1029-Q1 LIN transceiver. Lastly, these multiple BLE satellite nodes must operate when the vehicle engine is not running therefore, the total power consumption must be reduced. Accordingly, this reference design implements a single TPS7B82-Q1 ultra low-Iq LDO and leverages the wake over LIN feature the TLIN1029-Q1 offers.

The CC2640R2F-Q1 BLE MCU was chosen due to its flexibility, since it is a software defined radio with integrated memory, its ability to run a LIN slave protocol, its compliance to Bluetooth 5.0 standard and its automotive qualification. The CC2640R2F-Q1 handles the monitoring of a BLE connection (between the key fob and the central BLE module), the processing of the AoA and RSSI measurements and the LIN slave protocol.

The TLIN1029-Q1 LIN was chosen due to its ± 45 V DC fault protection, integrated transient protection, small 3-mm × 3-mm dual flat-pack no-lead (DFN) package, wake over LIN capabilities and automotive qualification. The TLIN1029-Q1 transceiver translates the logic level universal asynchronous receiver-transmitter (UART) signals from the CC2640R2F-Q1 to the battery level open-drain output of the LIN physical layer interface. In addition, the TLIN1029-Q1 waits in sleep mode for a wake signal from a LIN master and, once received, wakes the CC2640R2F-Q1 from standby mode.

The TPS7B82-Q1 LDO was chosen due to its ultra-low quiescent current at light loads (2.7 μ A typical and maximum of 5.0 μ A), its 8-pin micro small outline package (MSOP), and its automotive qualification. The TPS7B82-Q1 provides a regulated 3.3-V supply rail for the wireless MCU and logic level pull up voltage for the open-drain output of the LIN transceiver. The low quiescent current enables designers to have very low system quiescent current in low power modes while still having a regulated supply rail. This is important as BLE satellite nodes will have to operate even when the vehicle is turned off, therefore, the system is powered directly from the 12-V battery and must minimize power consumption as much as possible.

For PEPS applications there will typically be four or more of these BLE satellite node modules placed around the perimeter of the vehicle and at least one module placed inside the cabin of the vehicle for measuring the AoA and any other BLE characteristics, such as time of flight or received signal strength indication (RSSI), from the key fob to the vehicle. Each of these modules will remain in low power mode until a LIN wake message is broadcast over the LIN bus when the key fob is approaching. This LIN wake message is sent by the LIN master which is in the central security module, such as a base station module or body control module (BCM), and will individually wake one BLE node at a time. Once a BLE node is awake, the central security module will receive the AoA and any other important data from the node via LIN, and then tell the node to re-enter low power mode. All of the BLE satellite nodes will measure the incident angle, or AoA, along with any other BLE measurements (RSSI, ToF) and relay this information back to the central security module via LIN. The central module will aggregate this information and triangulate and trilaterate the position of the key fob to determine what system actions to perform like turning on welcome lights and puddle lights or unlocking the doors of the vehicle.

For remote keyless entry (RKE) applications a single BLE module like this design can be used to communicate with the key fob. The 2.4 GHz RF portion of the design can be simplified and made more compact since AoA measurements are not needed for RKE applications. Therefore, only one antenna structure is needed and the RF switch can be removed. Furthermore, the dipole antennas can be replaced with a single, smaller 2.4 GHz antenna to save additional space.

1.1 Key System Specifications

Table 1. Key System Specifications

PARAMETER	SPECIFICATIONS	DETAILS
Input power source (VBATT)	Automotive 12-V battery system	Section 2.4.1
Operational input voltage range (VBATT)	4.65 V to 40 V	Section 2.4.1
Survivable input voltage range (VBATT)	-40 V to 45 V	Section 2.4.1
Regulated voltage rail	3.3 V	Section 2.4.1
Average active-state current consumption (Estimate)	11 mA	
Average standby-state current consumption	13.7 μ A	
Radio transmission range	>30 meters	
Operating temperature	-40°C to 105°C	Section 2.3.1
Form factor	Rectangular, 45.72 mm x 76.2 mm (1.8" x 3.0"), 6-layer, 1-oz copper foil, printed circuit board (PCB)	Section 4

2 System Overview

2.1 Block Diagram

Figure 1. TIDA-01632 Block Diagram

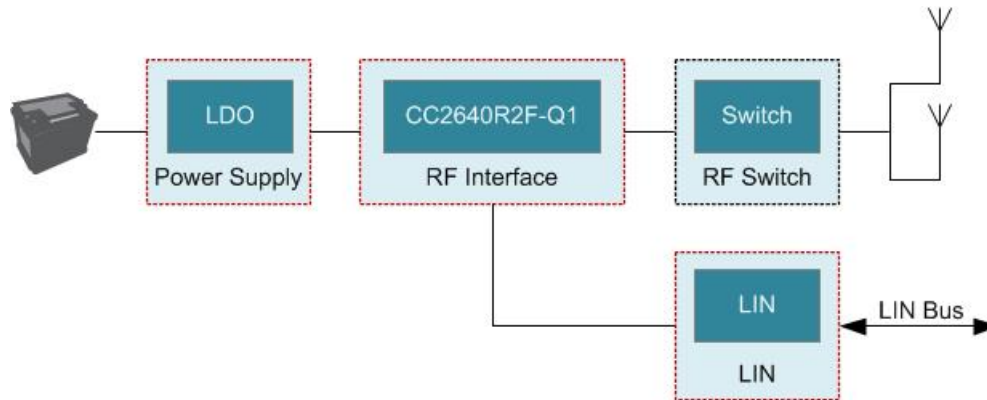

2.2 Design Considerations

The main design consideration was the two dipole antennas designed to measure the angle of arrival from a 2.4-GHz BLE signal. Keeping the antennas as small as possible was a main focus, as the dipole antennas limit the overall board shape and size. Furthermore, dipole antennas work well for this application as they do not have high directivity and radiate well perpendicular to the PCB plane.

A single small (10 mm × 8 mm × 5 mm) terminal block is used to connect power, ground, and LIN to the module. The connector size was also an important consideration to help simplify layout and ensure a compact PCB. A push-in spring connector was picked for ease of removing and adding wires to the board. In addition to the main terminal block connector, a 6-pin header is used for a direct connection to the CC2640R2F-Q1 device. This allows for access to the UART, VDDS, digital input/output (DIO) 5, and DIO 6 pins of the CC2640R2F-Q1 device for debug purposes.

Another consideration is the selection of passive components. Generally, components are selected based on the performance requirements of the applications. For active components, AEC-Q100 qualified parts are used, qualified for either temperature grade 0 or temperature grade 1. Capacitors are generally X7R grade (–55°C to +125°C) or higher. In addition, capacitors are selected with voltage ratings greater than the maximum voltage they could experience and two times the typical operating voltage to avoid DC bias effects.

2.3 Highlighted Products

The TIDA-01632 BLE satellite node reference design features the following three automotive qualified TI devices:

- CC2640R2F-Q1: Automotive Qualified SimpleLink™ Bluetooth low energy Wireless MCU
- TLIN1029-Q1: Automotive Qualified Local Interconnect Network (LIN) Transceiver With Dominant State Timeout and Low Power Wake Receiver
- TPS7B8233-Q1: Automotive Qualified 300-mA High-Voltage Ultra-Low- I_q Low-Dropout (LDO) Regulator

For more information on each of these devices, see their respective data sheets in [Section 6](#) or their product folders listed in [Resources](#) of this design guide.

2.3.1 CC2640R2F-Q1

The SimpleLink Bluetooth low energy CC2640R2F-Q1 device is an AEC-Q100 compliant wireless microcontroller (MCU) targeting Bluetooth 4.2 and Bluetooth 5.0 low energy automotive applications such as PEPS, remote keyless entry (RKE), car sharing, piloted parking, cable replacement, and smartphone connectivity.

The device is a member of the SimpleLink ultra-low power family of cost-effective, 2.4-GHz RF devices. Very low active RF and MCU current and low-power mode current consumption provide excellent battery lifetime allowing for operation on small coin-cell batteries and a low power-consumption footprint for nodes connected to the car battery. Excellent receiver sensitivity and programmable output power provides industry leading RF performance that is required for the demanding automotive RF environment.

The CC2640R2F-Q1 wireless MCU contains a 32-bit ARM® Cortex®-M3 processor that runs at 48 MHz as the main application processor and includes the Bluetooth 4.2 low energy controller and host libraries embedded in ROM. This architecture improves overall system performance and power consumption and frees up significant amounts of flash memory for the application.

Additionally, the device is AEC-Q100 Qualified at the Grade 2 temperature range (−40°C to +105°C) and is offered in a 7-mm × 7-mm VQFN package with wettable flanks. The wettable flanks help reduce production-line cost and increase the reliability enabled by optical inspection of solder points. The Bluetooth low energy Software Stack is available free of charge from www.ti.com.

Figure 2 shows a block diagram of the device.

Figure 2. CC2640R2F-Q1 Block Diagram

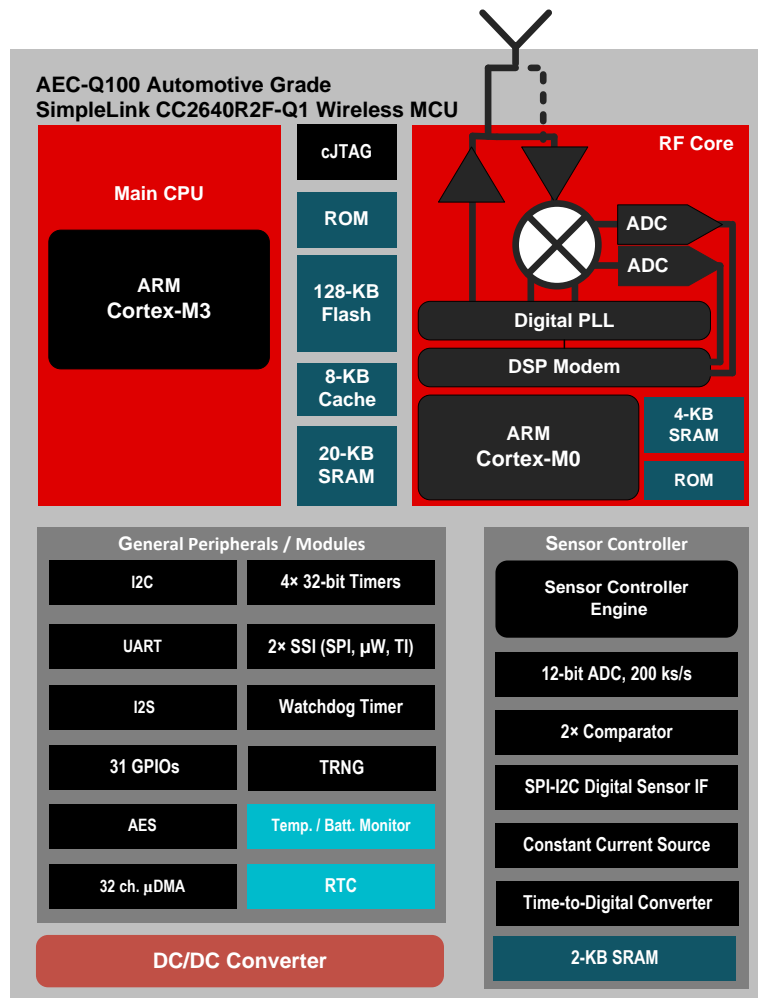

Additional features:

- Qualified for Automotive Applications
- Integrated Powerful ARM Cortex-M3
- 275-KB Nonvolatile Memory, Including 128-KB In-System Programmable Flash
- Ultra-Low Power Sensor Controller
- 2.4-GHz RF Transceiver Compatible with BLE 4.2 and 5 Specifications and Compliant to Worldwide Radio Frequency Regulations
- Link budget of 102 dB for BLE at 1 Mbps
- Efficient Code Size Architecture, Placing Drivers, Bluetooth low energy Controller, and Bootloader in ROM to Make More Flash Available for the Application
- Four General-Purpose Timer Modules (Eight 16-Bit or Four 32-Bit Timers, PWM Each)
- 12-Bit ADC, 200-kSPS, 8-Channel Analog MUX
- AES-128 Security Module
- RoHS-Compliant Automotive Grade Package: 7-mm x 7-mm RGZ VQFN48 With Wettable Flanks

2.3.2 TLIN1029-Q1

The TLIN1029-Q1 is a Local Interconnect Network (LIN) physical layer transceiver with integrated wakeup and protection features that is compliant to LIN 2.0, LIN 2.1, LIN 2.2, LIN 2.2A and ISO/DIS 17987–4.2 standards. LIN is a single wire bidirectional bus typically used for low speed in-vehicle networks using data rates up to 20 kbps.

The TLIN1029-Q1 is designed to support 12 V applications with wider operating voltage and additional bus-fault protection. The LIN receiver supports data rates up to 100 kbps for in-line programming. The TLIN1029-Q1 converts the LIN protocol data stream on the TXD input into a LIN bus signal using a current-limited wave-shaping driver which reduces electromagnetic emissions (EME). The receiver converts the data stream to logic level signals that are sent to the microprocessor through the open-drain RXD pin. Ultra-low current consumption is possible using the sleep mode which allows wake-up via LIN bus or EN pin. The integrated resistor, ESD and fault protection allows designers to save board space in their applications.

Figure 3 shows a block diagram of the device.

Figure 3. TLIN1029-Q1 Block Diagram

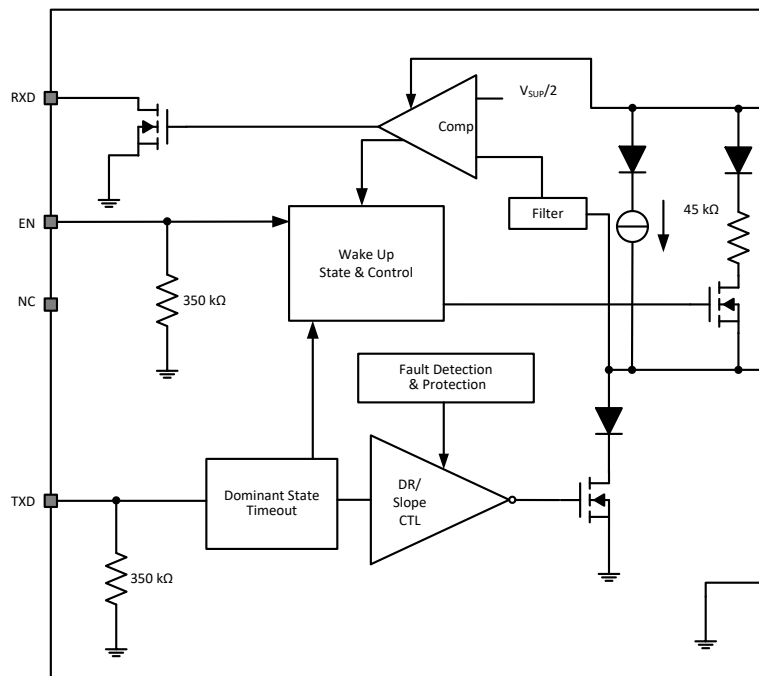

Additional features:

- Qualified for Automotive Applications
- Compliant to LIN 2.0, LIN 2.1, LIN 2.2, LIN 2.2A and ISO/DIS 17987–4.2
- Conforms to SAEJ2602 Recommended Practice for LIN
- Supports 12 V Applications
- LIN Transmit Data Rate up to 20 kbps
- LIN Receive Data Rate up to 100 kbps for in-line programming
- Ultra-Low Current Consumption Sleep Mode with Wake from LIN Bus and Local Wake up through EN
- Wide Operating Ranges for Supply Voltage from 4 V to 36 V
- Wide Bus Fault Protection on LIN Bus of ± 45 V
- Available in SOIC (8) Package and 3 mm \times 3 mm Leadless VSON (8) Package with Improved Automated Optical Inspection (AOI) Capability

2.3.3 TPS7B8233-Q1

In automotive battery-connected applications, low quiescent current (I_Q) is important to save power and extend battery lifetime. It is especially necessary to have ultra-low I_Q for always-on systems.

The TPS7B82-Q1 is a low-dropout linear regulator designed for up to 40-V VIN applications. With only 2.7- μ A typical quiescent current at light load, it is an optimal solution for powering microcontrollers and CAN/LIN transceivers in stand by systems.

The device features integrated short-circuit and overcurrent protection. This device operates in ambient temperatures from -40°C to 125°C and with junction temperatures from -40°C to 150°C . Additionally, this device uses a thermally conductive package to enable sustained operation despite significant dissipation across the device. Because of these features, the device is well suited as a power supply for various automotive applications.

Figure 4 shows a block diagram of the device.

Figure 4. TPS7B8233-Q1 Block Diagram

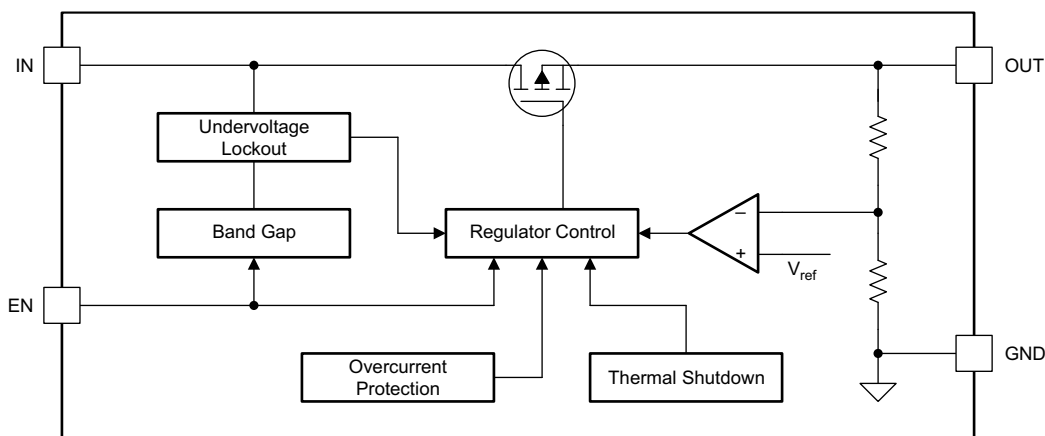

Additional features:

- Qualified for Automotive Applications
- Device Junction Temperature Range: -40°C to 150°C
- 3-V to 40-V Wide VIN Input Voltage Range With up to 45-V Transient
- Maximum Output Current of 300 mA
- Low Quiescent Current in Shutdown Mode of 300 nA Typical (when EN = Low)
- Low Quiescent Current with Light Loads of 2.7 μA Typical (when EN = High)
- 2% Output-Voltage Accuracy
- Stable with Low-ESR (0.001- Ω to 5- Ω) Ceramic Output-Stability Capacitor (1 μF to 200 μF)
- Fixed 5-V and 3.3-V Output Voltage Versions
- Integrated Thermal Shutdown, Short-Circuit and Overcurrent Protection
- 8-Pin MSOP Package with Thermal Resistance ($R_{\theta JA}$): 63.9°C/W

2.4 System Design Theory

The following system design theory section covers each portion of the schematic for the TIDA-01632 and provides details on hardware selection and implementation.

2.4.1 Supply Protection, Filtering, and Regulation

Figure 5 shows the portion of the schematic that has the main 3-pin terminal block, transient protection diode, reverse blocking diode, bulk input capacitance, low-dropout (LDO) regulator, and input and output filtering capacitors for the LDO.

- **Connector J8:** 3-pin terminal block with screw terminal connection. Pin 1 is used for the ground connection, pin 2 is the LIN interface connection and pin 3 is the vehicle battery input connection
- **Capacitor C2:** Input capacitor placed as close to the external connector as possible to help filter high frequency RF noise
- **Diode D9:** 600 W peak power transient voltage suppressor (TVS) diode for clamping external electrostatic discharge (ESD) and automotive battery transients with typical breakdown at 39 V
- **Diode D1:** 200 V 200 mA switching diode used for reverse voltage protection
- **Capacitors C3 and C4:** bulk and bypass capacitance for filtering any battery variations on the VSUP input supply rail
- **Resistor R1:** Used to configure the TPS7B8233-Q1 LDO to be always on and maintain a regulated 3.3 V output
- **IC U1:** Wide-input voltage LDO with ultra-low quiescent current used for regulating the automotive battery input voltage to a clean 3.3-V rail for the wireless MCU and LIN RXD open-drain output its small package size (MSOP), and its automotive qualified
- **Capacitor C1:** Low equivalent series resistance (ESR) output capacitor to ensure stability of the TPS7B8233-Q1 during any load transients

Figure 5. Supply Protection, Filtering, and Regulation Circuitry

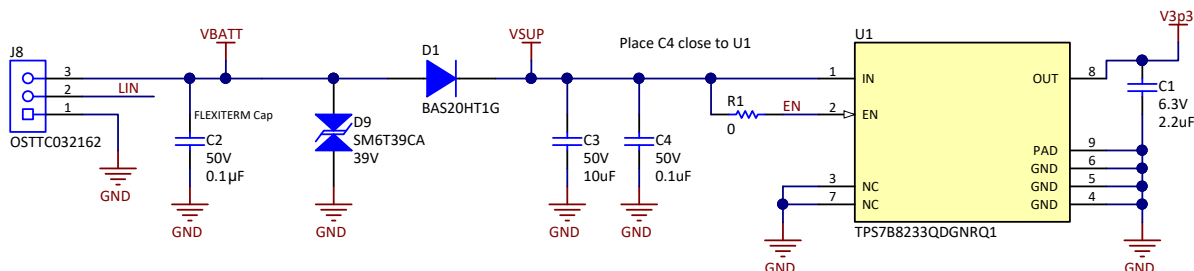

The TPS7B8233-Q1 has a maximum drop out of 350 mV at 100 mA of output current and the series reverse blocking diode has a maximum forward voltage of 1 V at 100-mA load current. Therefore, the TIDA-01632 minimum operating input voltage can be calculated by taking the desired regulated output (3.3 V) and adding the dropout of the LDO (350 mV) and the series forward voltage drop of the reverse blocking diode (1.0 V). This results in a minimum input voltage of 4.65 V where the design maintains a 3.3-V regulated output voltage. Additionally, the TPS7B8233-Q1 device can maintain a regulated output voltage for input voltages up to 40.0 V.

Lastly, the 3.3 V LDO was configured to remain on at all times to allow the system to either wake from BLE messages or wake from broadcasted wake-up signals on the LIN bus. To further improve the minimum operable input voltage of the TIDA-01632 design, diode D1 can be replaced with a Schottky diode which has a lower forward voltage drop.

2.4.2 Automotive Qualified SimpleLink™ Bluetooth® Low Energy Wireless MCU

Figure 6 shows the wireless MCU and all of its required external circuitry, the UART debugging interface, the discrete BALUN, and the RF filtering circuitry portion of the schematic.

- **Capacitors C7, C8, C9, C10, C11, C12, C13 and C25:** 100-nF decoupling capacitors for each supply input pin of the CC2640R2F-Q1
- **Inductor L2 and capacitor C14:** The data sheet recommended values for the LC output filter for the integrated buck switching regulator on the CC2640R2F-Q1
- **Connector J3:** 6-pin 100 mil header with the TX and RX signals of the UART, the VDDS power rail, the ground net, DIO 5, and DIO 6. This header was used for debugging the design and externally monitoring the UART pins. This connector can be removed to save PCB area.
- **Crystal Y1:** 24-MHz clock source for the CC2640R2F-Q1
- **Crystal Y2 and capacitors C18 and C19:** 32.768 KHz clock source with data sheet recommended 12-pF load capacitors
- **Inductors L4 and L5 and capacitors C22, C23 and C24:** RF filtering and matching network. C22 is the DC blocking capacitor and creates a high pass filter whereas inductors L4 and L5 and capacitors C23 and C24 allow a low-pass filter to be created. The combined high-pass filter and low-pass filtering circuitry operates as a band pass filter with low-pass corner frequency of 3.55 GHz which is just above the operating frequency of Bluetooth.
- **Inductors L3 and L6 and capacitors C17, C21 and C26:** These components make up the discrete BALUN which converts the RF signal from single-ended to differential, or differential to signal ended. For example the received RF signal from the RF switch (U4 in Figure 8) is single-ended and the input to the CC2640R2F-Q1 is differential. To further decrease the solution size of the RF portion of the design an integrated matched BALUN plus band pass filter component like the 2450BM14G0011 from Johanson Technology can be used which has a total footprint of 1.6 mm × 0.9 mm.

Figure 6. Automotive SimpleLink™ BLE Wireless MCU Circuitry

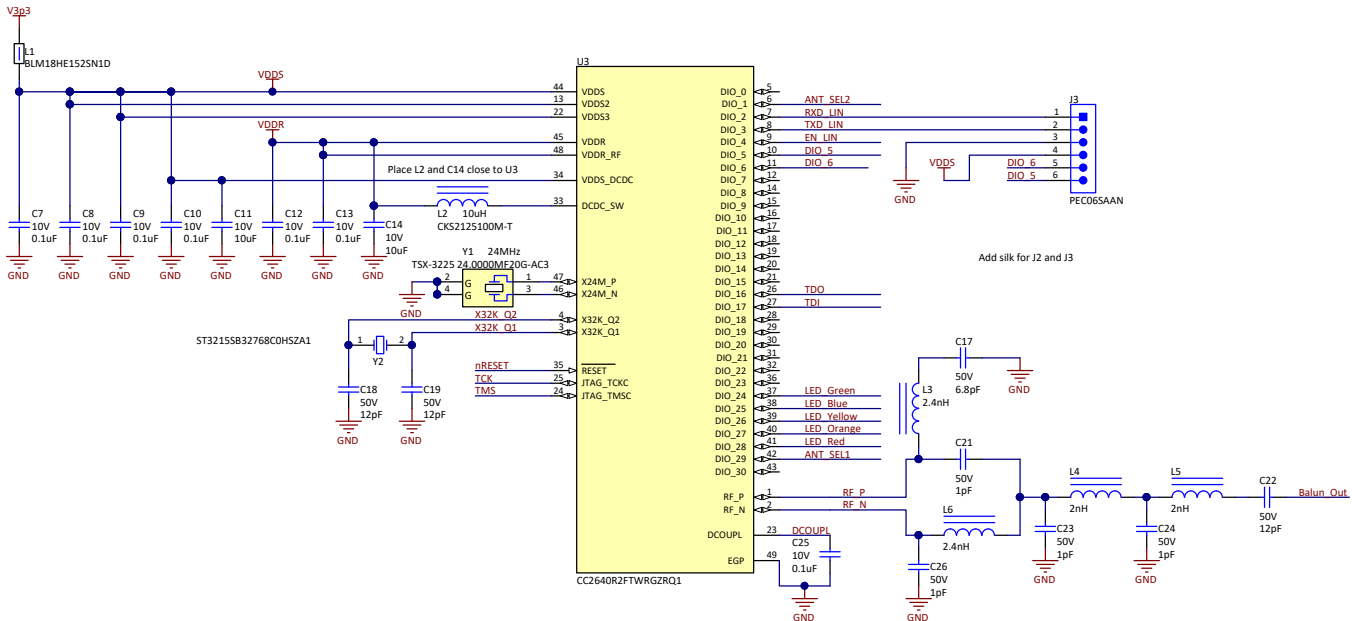

2.4.3 Automotive LIN Transceiver in 3 mm × 3 mm DFN Package

Figure 7 shows the LIN interface portion of the TIDA-01632 schematic.

- **Capacitor C6:** 100-nF decoupling capacitors for the supply input pin of the TLIN1029-Q1 as recommended by the data sheet
- **Resistor R5:** This resistor is used to ensure that the TLIN1029-Q1 is in low power sleep mode when the EN_LIN signal is not driven (in high impedance)
- **Resistor R2:** This is the required external pullup resistor for the open-drain RXD output of LIN receiver. This resistor is needed to pull RXD_LIN net high when the open-drain output pin is in the high impedance state.
- **Diode D2 and resistors R3 and R4:** These are the required LIN physical layer components for LIN master applications. For LIN slave applications these components can be removed to save PCB area.
- **Capacitor C5:** This LIN physical layer bus capacitor is used to help filter high frequency noise and transients, and the recommended typical value by the LIN standard is 220 pF.

Figure 7. Automotive LIN Transceiver Circuitry

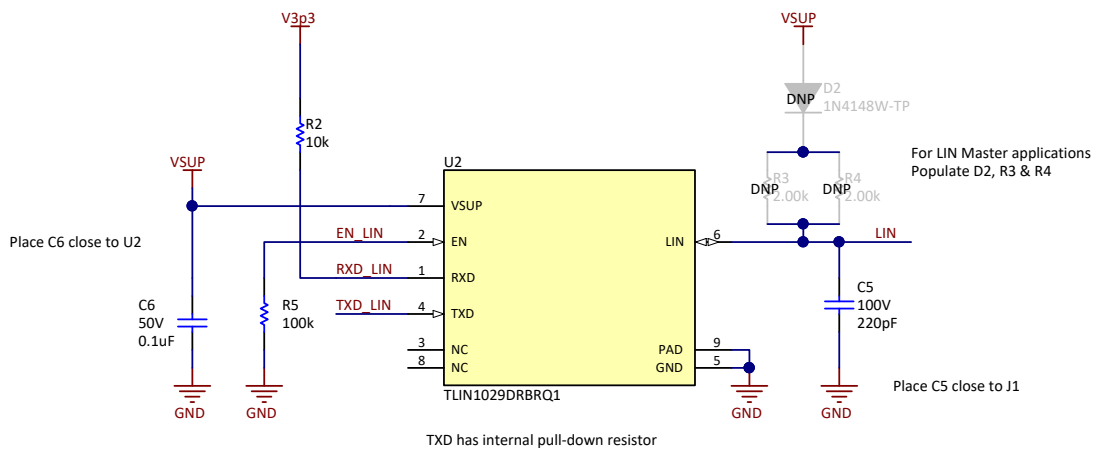

2.4.4 RF Switch for Collinear Antennas

To measure the incident angle of a BLE advertisement two or more collinear antennas are needed so that the phase of the received signal can be measured on each antenna and then the angle can be calculated. To make the design as compact as possible the minimum of two dipole antennas was used and a single pole double throw (SPDT) controlled impedance RF switch was used to switch between the two antennas. [Figure 8](#) shows the RF switch and the external circuitry.

Components R6 and C15, and R7 and C16 each create a low-pass filter on the two control inputs of the SPDT RF switch. They ensure that any noise on the control signals does not cause the switch to chatter.

Figure 8. Controlled Impedance RF Switch Circuitry

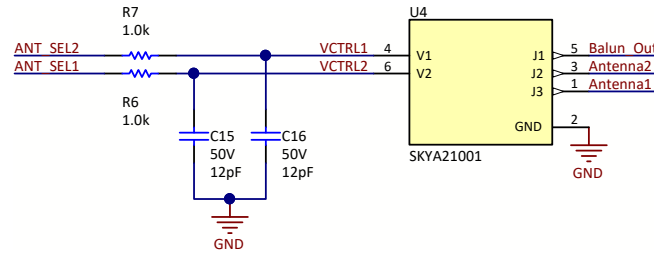

[Figure 9](#) and [Figure 10](#) show the PCB dipole antennas that were used for the design. [Figure 9](#) shows the two collinear dipole antenna structures that are on layer 3 of the PCB, and [Figure 10](#) shows the PCB BALUN which is used for converting the differential signal from the dipole antennas to a single ended signal to pass to the RF switch (U4). For more information on the antenna design, see [Section 4.3.2](#).

Figure 9. Dipole Antenna PCB Layer

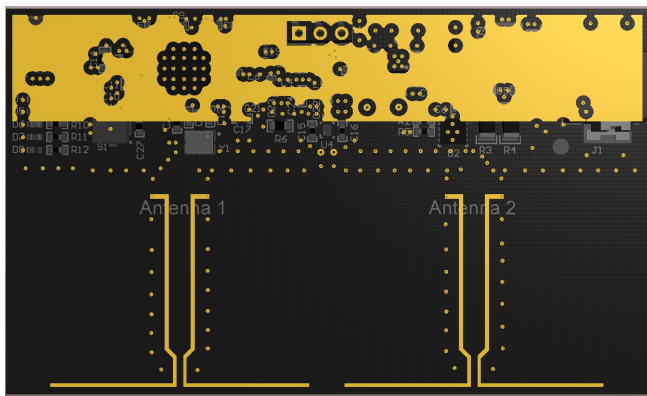
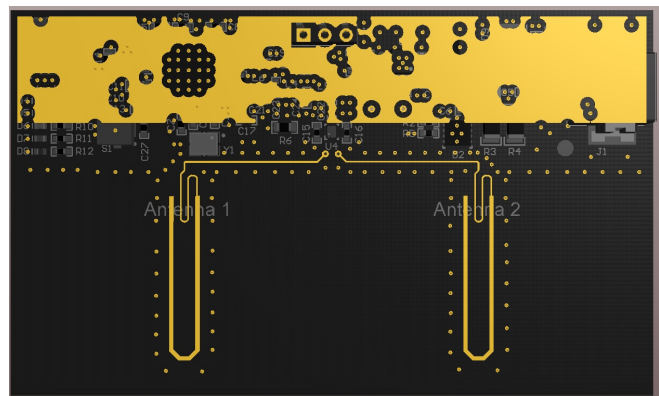

Figure 10. PCB BALUN



2.4.5 JTAG Programming Interface and Status LEDs

Device programming and on-chip debug support is done through J2 which has a dedicated compact Joint Test Action Group (cJTAG) interface (IEEE 1149.7) or JTAG (IEEE 1149.1) as Figure 11 shows.

- **Connector J2:** J2 is a 5 × 2, 50-mil header which was used with an external XDS110 USB to JTAG debug probe for programming and debugging
- **Switch S1:** This switch is an optional small surface mount momentary single pole single throw (SPST) push button that can be used to manually reset the CC2640R2F-Q1 wireless MCU and can be removed to save PCB area
- **Resistor R13:** This is a mandatory external pullup resistor that ensures the nReset net is pulled high when the debug tool is not connected. This resistor is needed since the RESET_N pin of the CC2640R2F-Q1 does not have an integrated pullup resistor or pullup current source.
- **Capacitor C27:** This capacitor was used for filtering the switch output

Figure 11. JTAG Programming and Debugging Interface Circuitry

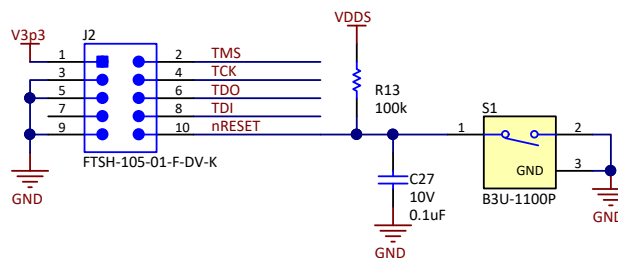

Lastly, five status LEDs have been added to the design for ease of evaluation and monitoring during testing. Figure 12 shows the status LED portion of the schematic. The series resistors have been chosen in an effort to match the intensity of all 5 LEDs and keep the nominal current below 5 mA for each LED so that they can be directly driven from the GPIO pins of the CC2640R2F-Q1 wireless MCU.

Figure 12. Status LED Circuitry

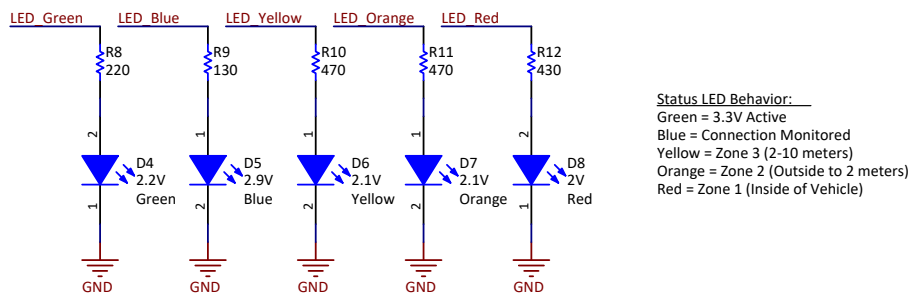

To save PCB area in a final solution test points can be used for the JTAG connections instead of connector J2, and switch S1, the status LEDs, and LED current limiting resistors can be removed.

3 Hardware, Software, Testing Requirements, and Test Results

3.1 Required Hardware

This section provides an overview of the TIDA-01632 board, the external connections, and the required hardware used to evaluate the reference design.

3.1.1 Hardware

To set-up and evaluate this design the following hardware was used:

1. Two TIDA-01632 BLE satellite node reference design PCBs. One boards was configured as a LIN master with D2, R3 and R4 populated, and one configured as a LIN slave with D2, R3 and R4 left unpopulated.
2. SimpleLink Bluetooth low energy CC2650 wireless MCU LaunchPad™ development kit. The top portion of the LaunchPad was used as a programming and debugging interface.
3. SimpleLink Bluetooth low energy CC2640R2F wireless MCU LaunchPad™ development kit. The LaunchPad was programmed to act as a key fob sending BLE angle of arrival packets that the TIDA-01632 board used to measure AoA and RSSI.
4. MIKROE-1766 1.27-mm flat cable. This cable was used to connect from the "XDS110 Out" programming connector on the CC2640R2F LaunchPad to JTAG programming connector J2 on the TIDA-01632 board.

Figure 13 shows all of these items.

Figure 13. Getting Started Hardware

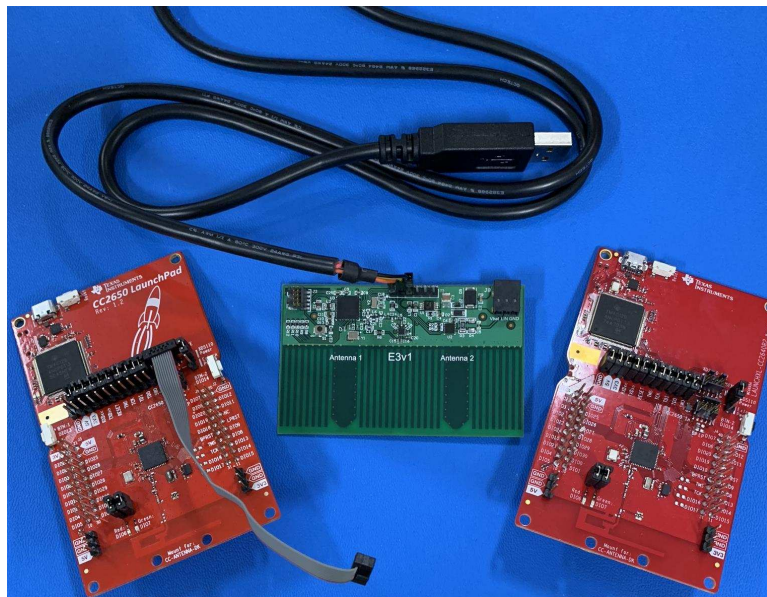

3.2 Required Software

3.2.1 Software

The CC2640R2F was programmed to monitor a BLE connection between a BLE central (that is, base station module) and BLE peripheral (that is, key fob) and calculate the angle of arrival of the signal received from a BLE key fob. Once the angle is calculated, that value is transmitted via LIN to the central control module. All software development started with the [SimpleLink™ CC2640R2 SDK](#) and was modified for the specific board pin out and LIN communications. [Figure 14](#) illustrates the software flow chart.

Figure 14. CC2640R2F-Q1 Flow Chart

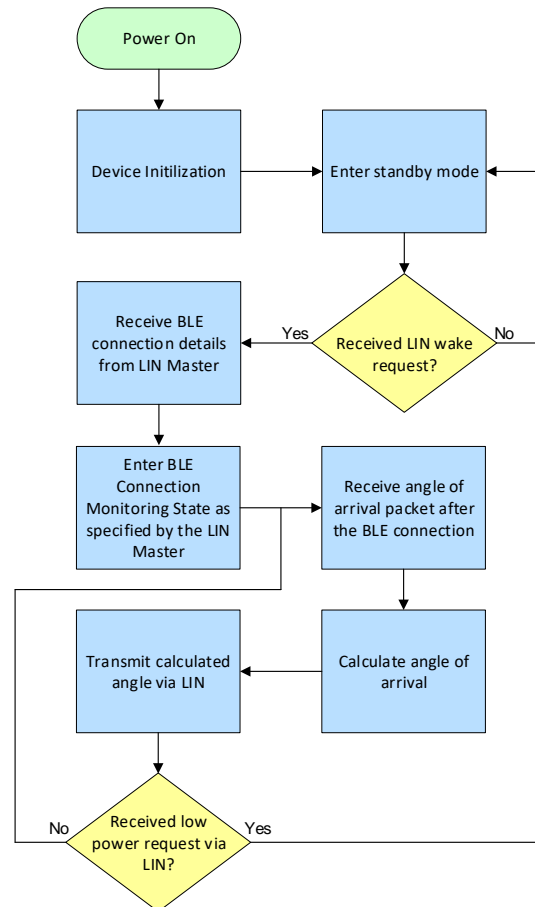

The CC2640R2F-Q1 is in a standby state until awoken from a LIN master (reducing the overall car access system power consumption). When a LIN wake request is received, the device will wake up and receive the BLE connection details such as channels, access address, and BLE connection event timings. Once this information is received, the CC2640R2F-Q1 begins monitoring the BLE connection between the LIN master module (also the BLE central) and the BLE peripheral (that is, key fob) based on the information received from the LIN master. Once the AoA packets are received, the CC2640R2F-Q1 calculates the AoA and transmits the data to the LIN master module. The CC2640R2F-Q1 will continually receive AoA packets, calculate the AoA, and transmit the data to the LIN master until the master requests for the CC2640R2F-Q1 to enter standby mode.

For more information on angle of arrival and how it is implemented, review the [angle of arrival](#) section of the SimpleLink CC2640R2 BLE-Stack User's Guide for Bluetooth 4.2. For more information on the CC2640R2F-Q1 BLE stack implementation and getting started with the SDK, review the [CC2640R2 BLE-Stack User's Guide for Bluetooth 4.2](#) and [SimpleLink Academy CC2640R2 SDK](#).

3.3 Testing and Results

The following items were evaluated on the TIDA-01632 design:

- Measuring AoA
- Transmitting AoA and RSSI data over LIN

3.3.1 Measuring AoA

An anechoic chamber with a mechanical arm inside the chamber was used to perform testing. [Figure 15](#) and [Figure 16](#) show the chamber and mechanical arm.

Figure 15. Anechoic Chamber

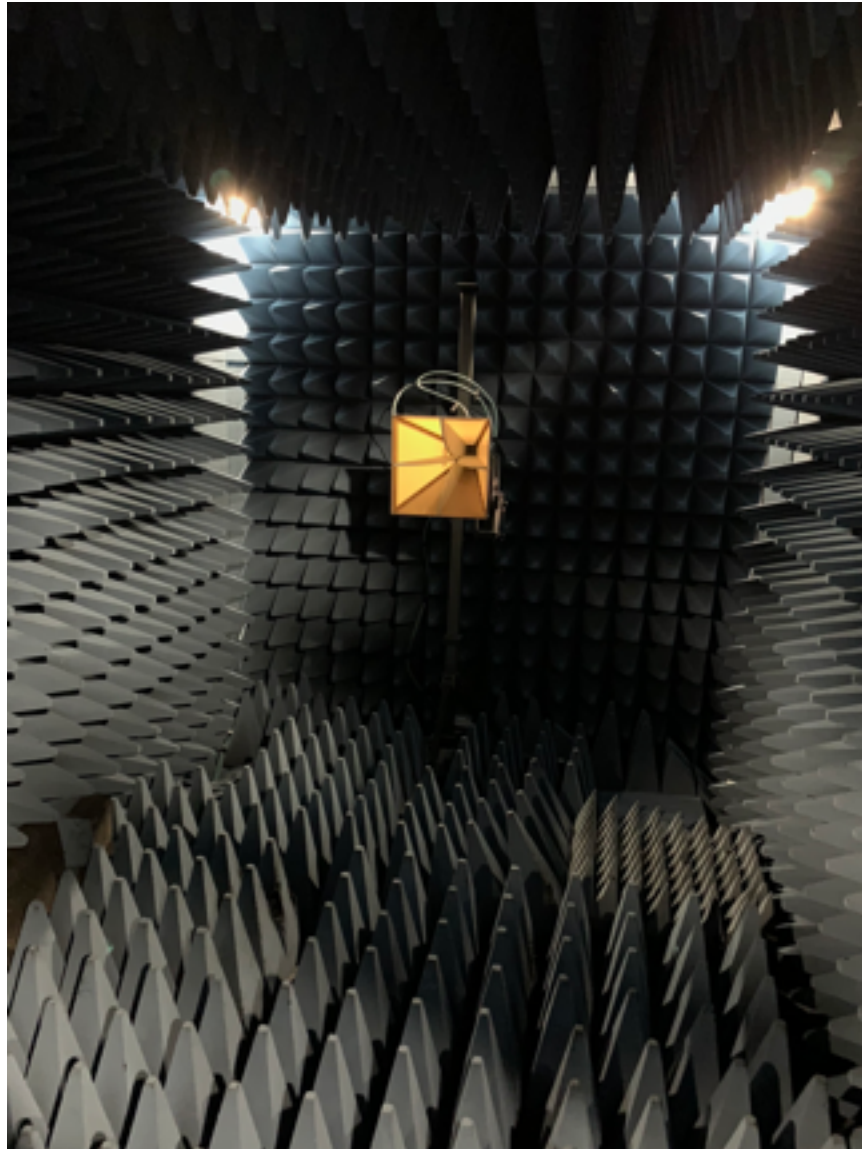
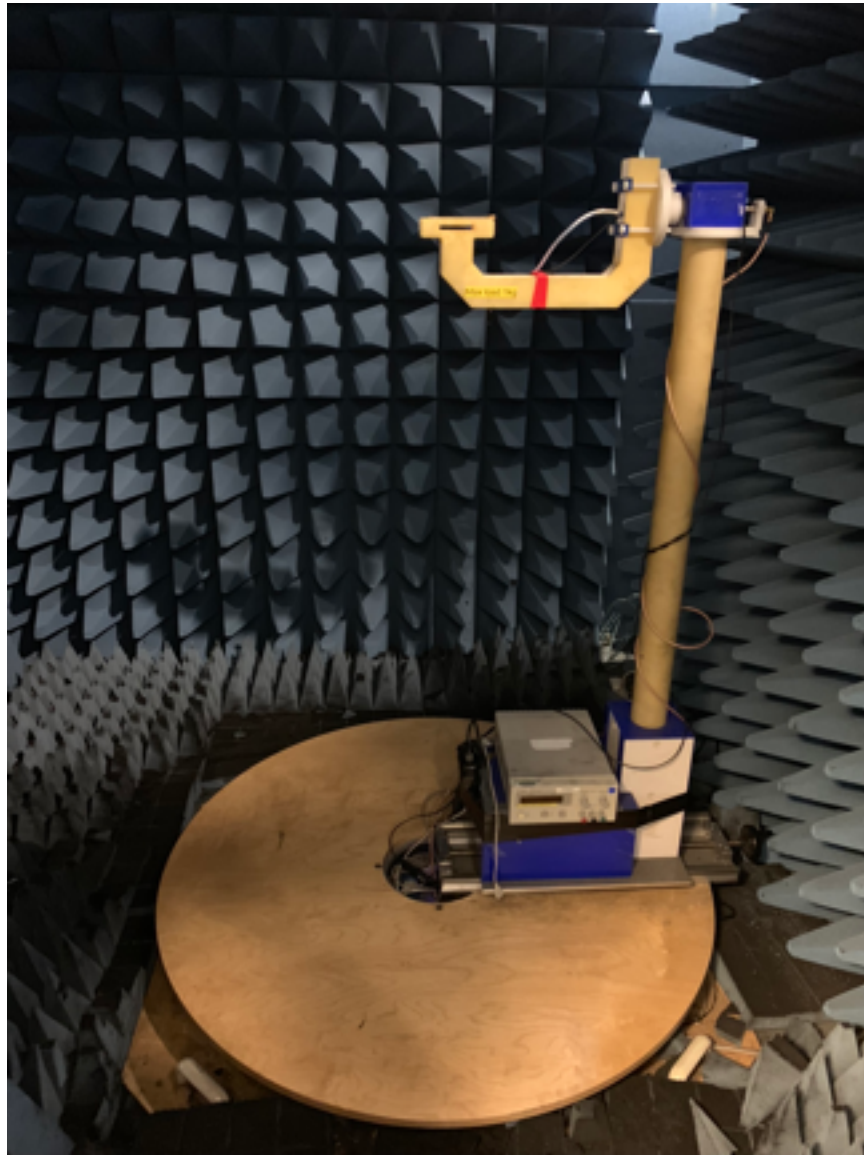

Figure 16. Mechanical Arm Setup



The mechanical arm is used to turn the AoA antenna 1 degree at a time. It is capable of rotating the BLE node in both the x and z directions. For testing, only rotating in the x direction is necessary to test the angle of arrival. A 0.8-mm thick metal structure was used to hold the board up and simulate the board being mounted on the metal body in an actual vehicle. A Wave-X EMI absorption sheet was also added between the metal and the PCB.

Figure 17 and Figure 18 show the setup.

Figure 17. PCB With Metal Structure Setup - Front



Figure 18. PCB With Metal Structure Setup - Back

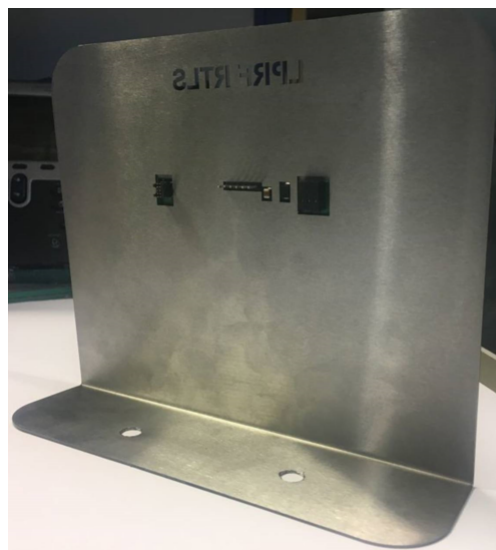
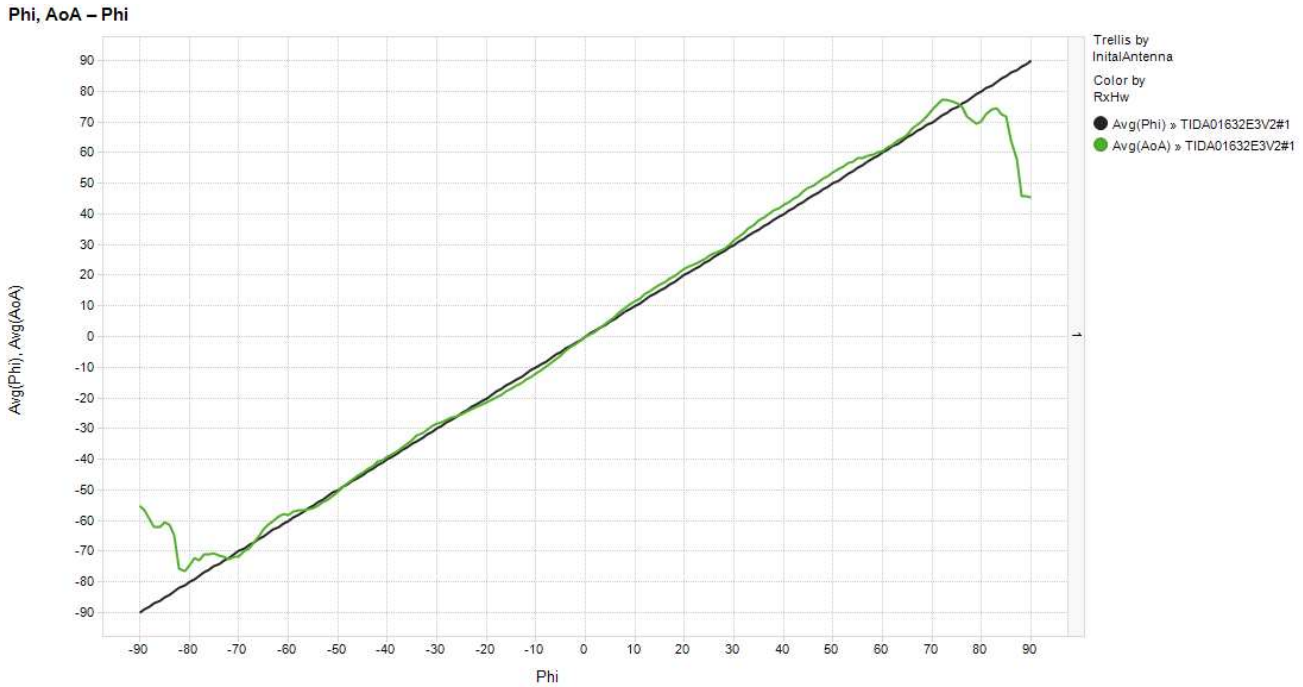

Figure 19 shows the calculated angle of arrival results.

Figure 19. Measured AoA vs Actual AoA Results



The results show the average AoA results using 13 different BLE channels. The black line represents the ideal result where the measured AoA equals the actual AoA and the green line shows the average of the AoA measurements of the 13 different channels. Figure 20 shows the error from the measured AoA and the actual AoA.

Figure 20. AoA Measurement Error

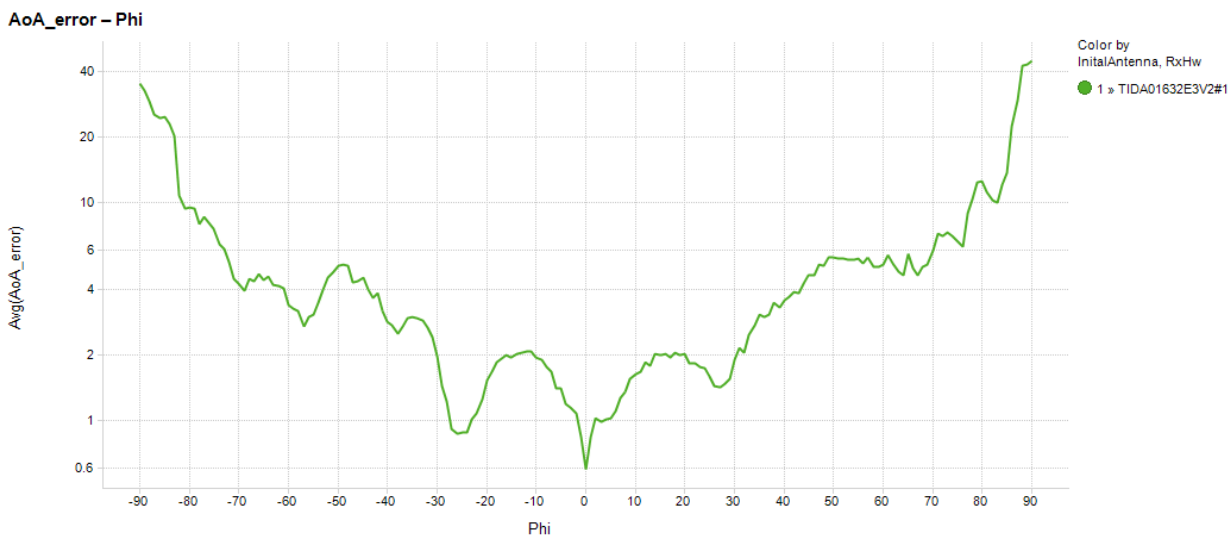

The design achieves less than 10° of error until around ±80°.

3.3.2 Transmitting AoA and RSSI Data Over LIN

The calculated AoA and RSSI values are transmitted via LIN. Figure 21 shows the LIN data analyzed with a LIN serial debug tool. Software was developed to demonstrate LIN communication capabilities.

Figure 21. AoA and RSSI LIN Communication

To Configure the LIN Analyzer, go to: Tools and Options -> Configure LIN Analyzer

Time Stamp (sec)	Frame ID	Frame Data	Checksum	Checksum Type
2653.823316	4C	00 1E D8 07 64 00 00 00	51	Enhanced
2653.873214	4C	00 1E D8 07 64 00 00 00	51	Enhanced
2653.923930	4C	00 1E D7 07 82 00 00 00	34	Enhanced
2653.971783	4C	00 1E D7 07 82 00 00 00	34	Enhanced
2654.022908	4C	00 1E D7 07 82 00 00 00	34	Enhanced
2654.072806	4C	00 1E D7 07 82 00 00 00	34	Enhanced
2654.121886	4C	00 1E D8 07 64 00 00 00	51	Enhanced
2654.172602	4C	00 1E D8 07 64 00 00 00	51	Enhanced
2654.222500	4C	00 1E D7 07 64 00 00 00	52	Enhanced
2654.273625	4C	00 1E D7 07 64 00 00 00	52	Enhanced
2654.322296	4C	00 1E D7 07 A1 00 00 00	15	Enhanced
2654.374239	4C	00 1E D7 07 A1 00 00 00	15	Enhanced
2654.423319	4C	00 1E D7 07 82 00 00 00	34	Enhanced
2654.474444	4C	00 1E D7 07 82 00 00 00	34	Enhanced

The first and second bytes represent the calculated angle, the third byte is the measured RSSI and the fourth and fifth bytes are the execution time.

4 Design Files

4.1 Schematics

To download the schematics, see the design files at [TIDA-01632](#).

4.2 Bill of Materials

To download the bill of materials (BOM), see the design files at [TIDA-01632](#).

4.3 PCB Layout Recommendations

This section covers the following topics:

- BLE Wireless Microcontroller Layout Considerations
- Antenna Design Layout Considerations
- LIN Transceiver Layout Considerations
- LDO Layout Considerations
- Board Layer Stackup
- Layout Prints

4.3.1 BLE Wireless Microcontroller Layout Considerations

See the *Application, Implementation, and Layout* section of the [CC2640R2F-Q1 SimpleLink™ Bluetooth® low energy Wireless MCU for Automotive](#) data sheet for more information on layout recommendations. [Section 6](#) has links to all the device data sheets used in this design.

4.3.2 Antenna Design Layout Considerations

Two quarter-wave dipole PCB antennas were designed to measure the angle of arrival. The dipoles measure 30.8-mm wide with a gap between the two antennas set to 4.2 mm. Quarter-wave dipole antennas are required in this design to ensure that the phase centers of the two antenna are less than half a wavelength distance from each other. In this case, the antennas are 35 mm apart from center-to-center, well below a half of a 2.4-GHz wavelength (62.5 mm).

4.3.3 LIN Transceiver Layout Considerations

See the *Layout* section of the [TLIN1029-Q1 Local Interconnect Network \(LIN\) Transceiver with Dominant State Timeout](#) data sheet for more information on layout recommendations. [Section 6](#) has links to all the device data sheets used in this design.

4.3.4 LDO Layout Considerations

See the *Layout* section of the [TPS7B82-Q1 300-mA High-Voltage Ultralow-IQ Low-Dropout Regulator](#) data sheet for more information on layout recommendations. [Section 6](#) has links to all the device data sheets used in this design.

4.3.5 Board Layer Stackup

The TIDA-01632 reference design board has been designed using six layers. Both top and bottom layers have signals and power traces routed, but a majority of the bottom layer has been used for a large, low-impedance ground plane. See [Table 2](#) for the board stackup. The board is a 45.72 mm × 76.2 mm (1.9" × 3.0"), 6-layer, 1/2-oz copper foil with 1-oz plating on top and bottom, printed circuit board (PCB). The total board thickness is approximately 35.6 mils.

Table 2. TIDA-01429 Board Layer Stackup

LAYER NAME	TYPE	MATERIAL	THICKNESS (MIL)	DIELECTRIC MATERIAL	DIELECTRIC CONSTANT
Top overlay	Overlay	—	—	—	—
Top solder	Solder mask	Surface material	0.4	Solder resist	—
Top layer	Signal	Copper	1.9	—	—
Dielectric 1	Dielectric	Core	4.2	FR-4	4.1
Layer 2	Signal	Copper	0.7	—	—
Dielectric 2	Dielectric	Core	8.0	FR-4	4.1
Layer 3	Signal	Copper	0.7	—	—
Dielectric 3	Dielectric	Core	3.8	FR-4	4.1
Layer 4	Signal	Copper	0.7	—	—
Dielectric 4	Dielectric	Core	8.0	FR-4	4.1
Layer 5	Signal	Copper	0.7	—	—
Dielectric 5	Dielectric	Core	4.2	FR-4	4.1
Bottom layer	Signal	Copper	1.9	—	—
Bottom solder	Solder mask	Surface material	0.4	Solder resist	—
Bottom overlay	Overlay	—	—	—	—

4.3.6 Layout Prints

To download the layer plots, see the design files at [TIDA-01632](#).

4.4 Altium Project

To download the Altium Designer® project files, see the design files at [TIDA-01632](#).

4.5 Gerber Files

To download the Gerber files, see the design files at [TIDA-01632](#).

4.6 Assembly Drawings

To download the assembly drawings, see the design files at [TIDA-01632](#).

5 Software Files

To download the software files, see the design files at [TIDA-01632](#).

6 Related Documentation

1. Texas Instruments, [CC2640R2F-Q1 SimpleLink™ Bluetooth® low energy Wireless MCU for Automotive Data Sheet](#)
2. Texas Instruments, [TLIN1029-Q1 Local Interconnect Network \(LIN\) Transceiver with Dominant State Timeout Data Sheet](#)
3. Texas Instruments, [TPS7B82-Q1 300-mA High-Voltage Ultralow-IQ Low-Dropout Regulator Data Sheet](#)

6.1 Trademarks

E2E, SimpleLink are trademarks of Texas Instruments.
 ARM, Cortex are registered trademarks of ARM Limited.
 Altium Designer is a registered trademark of Altium LLC or its affiliated companies.
 Bluetooth is a registered trademark of Bluetooth SIG, Inc.
 All other trademarks are the property of their respective owners.

7 Terminology

Passive Entry Passive Start (PEPS)—PEPS systems are a type of car access system where a user is able to approach their vehicle and the vehicle is able to wirelessly authenticate and position the approaching key fob and allow the user to gain access to the vehicle without needing to press any buttons on the key fob or use a traditional key to unlock the door.

Remote Keyless Entry (RKE)—RKE systems are a type of car access system where a user presses a button on a key fob to gain access to the vehicle without needing to use a traditional key to unlock the doors.

Bluetooth® Low Energy (BLE) —BLE is a 2.4-GHz wireless technology defined by the Bluetooth Special Interest Group (SIG) that is targeted for low power wireless communication.

Local Interconnect Network (LIN)—LIN is an automotive, single-wire, low-cost, low-speed, serial interface that is widely used in automotive applications world-wide.

Triangulation —When used in reference to a car access systems triangulation means that multiple angle of arrival (AoA) measurements are used to estimate the incident angle between known receiver module locations and an advertising node. These angles are then used to determine the absolute position of the advertising node using geometry.

Trilateration —When used in reference to a car access systems trilateration means that multiple received signal strength indicator (RSSI) measurements are used to estimate distance between known receiver module locations and an advertising node. These distances are then used to determine an absolute position of the advertising node using geometry.

Collinear —Collinear refers to any points or objects that lie on the same straight line. When used in reference to the antennas on this design it means that the antenna structures are on the same layers of the PCB and are justified to the same edge of the board. This ensures that any phase difference between the received signals of the 2 antennas is a result of the incident angle and not the layout of the board.

Low-Dropout (LDO) Regulator—An LDO is a direct current (DC) to DC voltage regulator that provides a regulated DC output voltage from a unregulated input voltage. LDOs are able to provide a regulated output voltage without the needing to switch on and off and are therefore lower noise than switching regulators and do not need inductors or transformers to provide the regulated output.

8 About the Author

John P. Griffith is a systems engineer at Texas Instruments. As a member of the Automotive Systems Engineering team, John specializes on body control modules, gateway modules and car access modules and creates end equipment block diagrams and reference designs for these automotive end equipments. John earned his bachelor of science and master of science in electrical engineering from Rochester Institute of Technology in Rochester, New York.

Donovan Porter is a systems engineer at Texas Instruments. As a member of the Automotive Systems Engineering team, Donovan specializes on body control modules, gateway modules and car access modules and creates end equipment block diagrams and reference designs for these automotive end equipments. Donovan earned his bachelor of science in electrical engineering from Texas Tech University in Lubbock, Texas.

Reidar Myhr is a RF HW Application Engineer at Texas Instruments. As a member of the Low Power Radio Frequency Application Engineering team, Reidar specializes in developing and testing low power RF designs. Reidar earned his Master of Science in Electrical Engineering (MSEE) from Norwegian University of Science and Technology (NTNU) in Trondheim, Norway.

David Lara is an Applications Engineer on the SimpleLink Customer Applications Team focused on automotive customers and has worked in TI embedded processing since 2012. David earned his masters of science in electrical engineering from New Mexico State University in Las Cruces, NM.

Revision History

NOTE: Page numbers for previous revisions may differ from page numbers in the current version.

Changes from Original (December 2018) to A Revision	Page
• Added author names.	23

IMPORTANT NOTICE AND DISCLAIMER

TI PROVIDES TECHNICAL AND RELIABILITY DATA (INCLUDING DATASHEETS), DESIGN RESOURCES (INCLUDING REFERENCE DESIGNS), APPLICATION OR OTHER DESIGN ADVICE, WEB TOOLS, SAFETY INFORMATION, AND OTHER RESOURCES "AS IS" AND WITH ALL FAULTS, AND DISCLAIMS ALL WARRANTIES, EXPRESS AND IMPLIED, INCLUDING WITHOUT LIMITATION ANY IMPLIED WARRANTIES OF MERCHANTABILITY, FITNESS FOR A PARTICULAR PURPOSE OR NON-INFRINGEMENT OF THIRD PARTY INTELLECTUAL PROPERTY RIGHTS.

These resources are intended for skilled developers designing with TI products. You are solely responsible for (1) selecting the appropriate TI products for your application, (2) designing, validating and testing your application, and (3) ensuring your application meets applicable standards, and any other safety, security, or other requirements. These resources are subject to change without notice. TI grants you permission to use these resources only for development of an application that uses the TI products described in the resource. Other reproduction and display of these resources is prohibited. No license is granted to any other TI intellectual property right or to any third party intellectual property right. TI disclaims responsibility for, and you will fully indemnify TI and its representatives against, any claims, damages, costs, losses, and liabilities arising out of your use of these resources.

TI's products are provided subject to TI's Terms of Sale (www.ti.com/legal/termsofsale.html) or other applicable terms available either on ti.com or provided in conjunction with such TI products. TI's provision of these resources does not expand or otherwise alter TI's applicable warranties or warranty disclaimers for TI products.

Mailing Address: Texas Instruments, Post Office Box 655303, Dallas, Texas 75265
Copyright © 2019, Texas Instruments Incorporated