

# High precision in motor drive control enables industrial advances



**Harald Parzuber**  
*Motor Drives Sector Manager,  
Industrial Systems Team  
Texas Instruments*

**Picture a robot in an automotive manufacturing plant. It picks up an engine block, moves it to a car chassis, places the block exactly, releases it, and returns to its original position to repeat the process. The robot can lift much greater weight than a human can, move items to specific spots more consistently, and repeat the same operation without stopping - 24 hours a day if necessary.**

---

Robots like this one have become the mainstay of manufacturing for automobiles and many other industries, and their use is ever-increasing. But robotics would be impossible to operate without precise motor drive control. At each point in its operation, a multi-axis robot has to employ different amounts of force in three dimensions in order to move the engine. Motors inside the robot supply variable speed and torque (rotational force) at precise points, which the robot's controller uses to coordinate motion along different axes for exact positioning. After the robot releases the car engine, the motors scale back the torque while returning the arm to its initial position.

Just as the control of motor drives enables advances in robotics and other areas, motor control itself depends on advances in electronics that make precise control possible during real-time operation. High-end power supplies, intelligent motor drivers, high-performance control signal processing, and exact sensing feedback all function together to deliver the precise speed and torque needed instantaneously by complex machines. The result is greater functionality, higher productivity and increased safety for both equipment and people.

As an industry leader in providing innovative technology for industrial applications, Texas Instruments (TI) offers a wide range of integrated solutions that enable the development of

advanced motor control systems. TI provides design engineers with integrated circuit (IC) products, including software and tools, that enable them to develop the increasingly precise control of motor drives that industries require. Based on years of engagement with leading motor manufacturers, TI's in-depth systems expertise helps engineers simplify the design of motor control systems while enhancing the performance of their products.

### **Benefits of motor control**

Controlling motor drives electronically introduces a level of precision that leads to lower costs, greater productivity and new manufacturing capabilities. Drive control ensures a stable rotor position relative

to the shunts, so that motor output is more predictable and power usage more efficient. When the load changes on a motor, electronic control can instantaneously modify the voltage input and torque delivered, thus matching the machine's output force and power consumption more closely to the application. Electronic input control also makes it possible to change drive speeds within the motor itself, instead of relying on expensive gears, belts and pulleys to output different speeds. Control enables stepper motors to move rotor positions in the small increments or microsteps required for robotic motion control. For all of these reasons, efficient operation enables applications to use controlled motors that are better scaled for the job, eliminating much of the overhead that would be otherwise required.

Operational efficiency goes hand in hand with increased productivity. For instance, a conveyor belt on an assembly line usually operates in tandem with other systems that load items on the belt, perform operations on the items, or receive them from the belt for further steps. Belts usually move with a consistent forward motion, but operation may sometimes require changing speeds, stopping or briefly reversing direction. These motions, together with continual changes of the number and weight of items on the belt, require controlled motor drives that can adjust the output automatically. Coordination among motors may be required as well, since multiple belts in the factory are often synchronized in order to keep items moving at an optimal rate. Controlled motors that keep belts moving predictably in changing conditions not only have a positive impact on the productivity of the entire plant, but play an essential role in a contemporary manufacturing environment.

Precisely controlled motors also enable new manufacturing capabilities. Robots offer the most

striking example, where electronically controlled motors provide fine-grade control of motion, often combined with strength and speed that go beyond those of humans. While the earlier example of a robot moving an engine block illustrates strength, other examples emphasize precision and/or speed of movement. Pick-and-place robots, for instance, repetitively perform fine motion control with tolerances measurable in micrometers, and usually far more rapidly than a human.

By helping remove human workers from high-speed, repetitive, sometimes dangerous tasks, electronically controlled motors make work environments safer. A new development within this trend is occurring today, as robots are being designed to operate safely in collaboration with human workers. While safety issues are often related to system operations and employee procedures, they also include the internal control electronics, which have to protect both equipment and workers from electrical discharges. Safety is always an important element in the design of industrial machines and the motors that run them.

## Design challenges for precise motor control

Many types of motors are used for specific tasks, but the majority of industrial motors run on three-phase power from an alternating current (AC) electrical supply. **Figure 1** shows a block diagram of the representative control electronics for such a system. AC power input is rectified to direct current (DC). A pulse-width modulation (PWM) switched three-phase inverter creates three high-frequency pulsed voltage waveforms that it outputs in separate phases to the three phase windings of the motor.

In these three power signals, changes in the motor load impact the current feedback that is sensed, digitized and sent to a digital processing unit

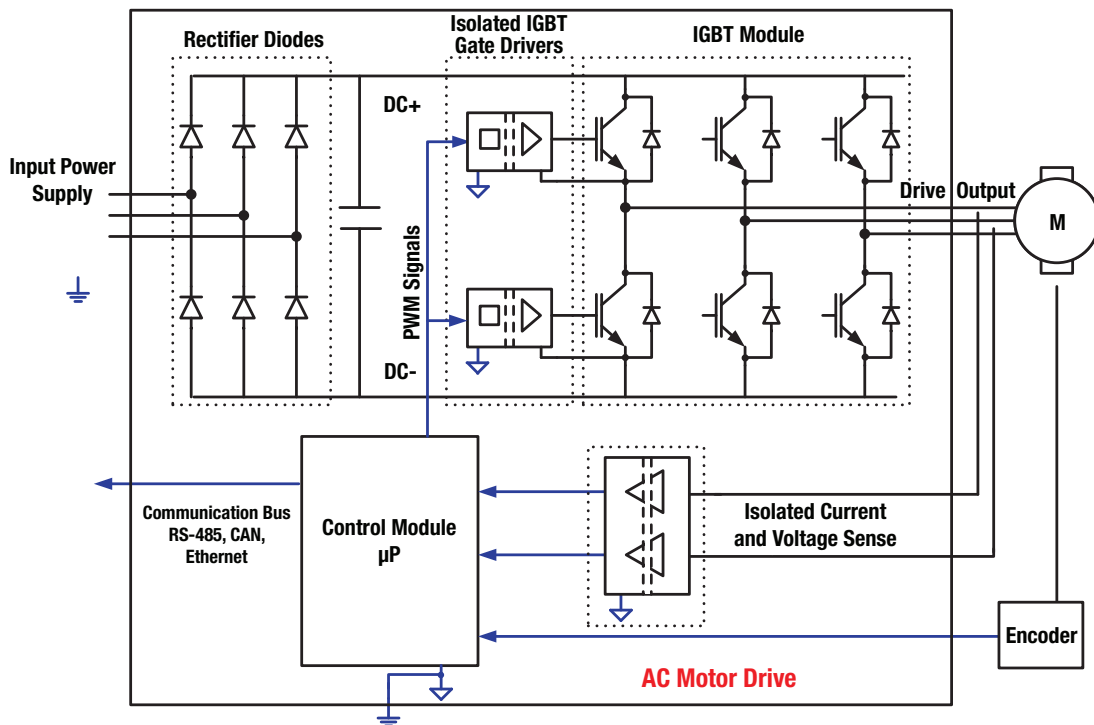

**Figure 1.** Control for a three-phase AC induction motor.

(like microcontrollers [MCUs], microprocessors [MPUs], processors or field-programmable gate arrays [FPGAs]). High-speed digital signal processing algorithms in the digital processing unit determine in real time whether changing conditions make it necessary to adjust the power being delivered. The processing unit sends a control output with PWM to the three-phase inverter in order to gate power switching and regulate the power outputs to the windings, thus supplying greater or lesser torque or speed from the motor. Additional sensing data may be fed into the controller to track system input voltage and temperature changes.

All of these components require a high level of performance for precise motor control. The switched-mode power supply (SMPS) to supply the control system must be capable of ultra-high-speed switching, controlled with consistently high resolution. Power-supply design is exacting because of the high voltages and frequencies involved and numerous passive components required, which

introduce mutually reactive impedances that are difficult to manage. Fortunately, new high-frequency materials and integrated SMPS modules are making it much easier to design high-performance power supplies in control systems.

Accurate motor control also requires extremely high-speed computation in real time, which is best supplied by microcontrollers with digital signal processor (DSP) capabilities. DSPs are also capable of performing digital filtering and other functions to help protect the system from power transients and other signal flaws, while at the same time reducing the need for analog components that perform these functions. While dedicated logic and general-purpose MCUs might be used for low-cost applications where basic control is sufficient, industrial motors in robots and other advanced manufacturing equipment require instantaneous response and accuracy, as well as the programming flexibility and advanced algorithms that digital signal control MCUs offer.

One of the biggest challenges of motor control systems is in designing high-resolution current and voltage sensing feedback. Designs may measure current feedback from only one shunt, but a more thorough (if more computation-intensive) approach measures feedback from all three shunts. To avoid the possibility of analog signal loss or interference, designers increasingly digitize feedback signals as close to the sensor as possible. However, digital feedback signals can have potential problems with timing, especially as clock speeds increase and sampling rates rise, which bring narrower timing windows. Different trace lengths for clocks and data signals can intensify this problem, potentially causing data errors if the signals drift as the components heat up during operation. Good design practices using advanced signal modulators can minimize these problems; algorithms that modify variables in keeping with temperature gain can compensate as well.

The more precise the application requirements, the more carefully the motor has to deal with changes in temperature, voltage input, timing and other factors. As an example, a robot arm that moves an object in a straight line in three-dimensional space may change its trajectory when the system is operating at a high temperature, unless the control design compensates for these changes with temperature sensing and algorithm adjustments. These same types of on-the-fly adjustments may be necessary to enable fine-grained robotic pick-and-place movements to consistently measure in micrometers, instead of drifting with heat into less precise movements with tolerances in millimeters. Given that manufacturing environments are often highly demanding in terms of temperature, dust, vibration and other stresses, it is even more important that motor control electronics be carefully designed for precise operation that is consistent throughout a wide range of conditions.

## TI's enabling technologies for motor drive control

TI offers the advanced technology needed to design precise motor control and reliable driver electronics that can operate effectively within today's integrated manufacturing environments. TI's solutions include isolated and non-isolated switching gate drivers, feedback signal conversion and high-speed processing for real-time control, as well as auxiliary functions such as programmable clock generators and DC/DC power supplies. For advanced SMPS and three-phase inverter designs, TI provides high-frequency gallium-nitride (GaN) gate drivers and modules that include GaN switches and gate drivers. For lower voltage three phase inverters, TI also provides high performance and reliable smart gate drivers, drivers with built-in FETs and drivers with integrated control which result in simplified but accurate control and very short development time. Products include safety features, such as reinforced isolation that meets industrial specifications, and are tested and qualified for use in harsh industrial environments. In addition, TI backs its integrated circuits with in-depth support that simplifies design and speeds development.

Among the most important recent TI innovations for motor control is the [AMC1306](#) isolated delta-sigma modulator, a device that digitizes signals from current and other sensors, then outputs a combined data and clock signal for maximum timing efficiency. The latest in the AMC1xxx family of isolated signal modulators, the AMC1306 integrates TI's integrated capacitive isolation technology in series to achieve reinforced isolation in a minimal footprint. Delta-sigma analog-to-digital conversion of the change in sensor output level is followed by Manchester coding of the clock rate onto the data stream, as shown in **Figure 2**.

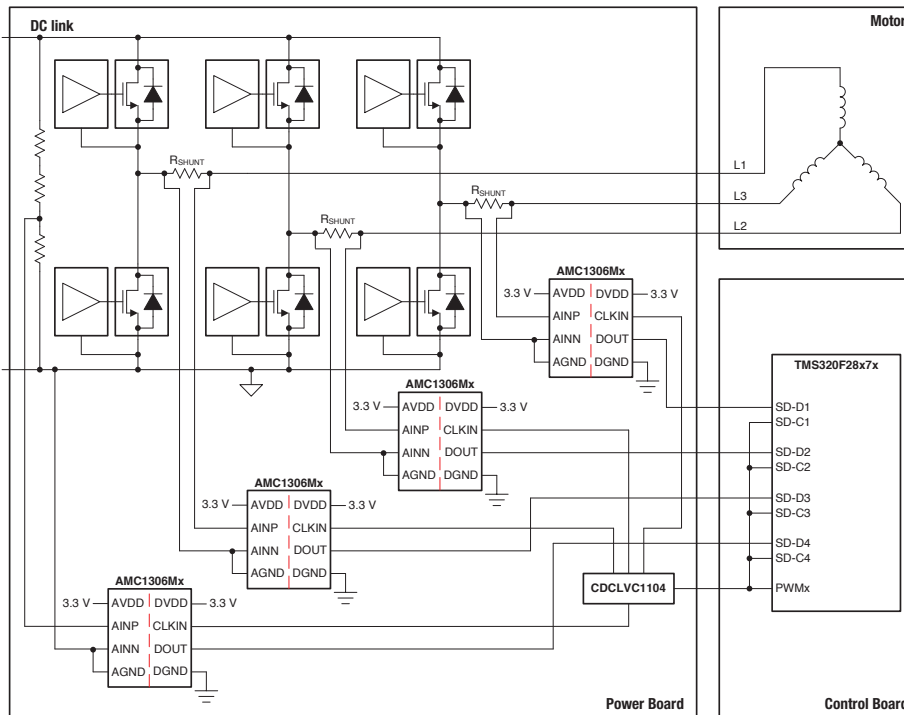

**Figure 2.** Reinforced isolated phase current sense reference design with small delta sigma modulators.

The result is a highly robust signal that significantly decreases problems with setup and hold times that can occur with changes in operating temperature, thus simplifying the design and routing of three-phase motor control systems.

### Manchester coding with clock embedded in data stream

To help designers implement the AMC1306 modulator, TI has created the [Reinforced Isolated Phase Current Sense Reference Design with Small Delta Sigma Modulators](#) reference design.

**Figure 2** shows the functions of the reference design, including the AMC1306 used for current, temperature and voltage-sensing signals. (The device is used for current sensing on all three power signals to the motor shunts, but to reduce detail it is shown for only one signal.) The dotted red line around the reference design's circuit indicates that it is effectively isolated for safety. Specific points of

reinforced isolation are indicated by breaks within the AMC1306 triangles, as well as by dotted red lines within the ISO53xxx insulated gate bipolar transistor (IGBT) switch drivers, which also feature TI's integrated capacitive isolation technology.

**Figure 2** shows control processing using a [TMS320F2837x Delfino™](#) 32-bit floating-point MCU, one of TI's extensive family of C2000™ MCUs, designed for high-performance computation and programming ease, plus a peripheral set for use in control systems. The C2000 DesignDRIVE software platform, with support for a wide variety of motor types, helps speed algorithm development and system implementation. InstaSPIN™ motor control solutions provide a wide variety of algorithms, tools and reference designs for evaluation, fast learning and quick development. TI's DSP and analog expertise combine in comprehensive solutions that save developers time in designing advanced motor drive control.

## Precise motors for integrated manufacturing

Industries are moving ahead with more precise control, greater communication among machines, a wider range of sensing inputs, and new capabilities in robotics and artificial intelligence. These advances are leading to a new level of integrated automation and data exchange that has been called the fourth industrial revolution (after the previous revolutions of steam-powered mechanization, assembly-line mass production and computer-aided automation).

Precisely controlled motors make an important contribution to this revolution, since they drive almost every motion made by industrial machines. TI's advanced technology has played a significant role in bringing about high-resolution motor control, and it continues to help manufacturers push motor and motion control to higher levels. Systems developers know they can turn to TI for a wide portfolio of IC solutions and in-depth support that helps advance the capabilities of their motor products while making design straightforward. As the fourth industrial revolution unfolds, TI and its customers are on the front line with leading technology.

## References

1. Anant S. Kamath, [Isolation in AC Motor Drives: Understanding the IEC 61800-5-1 Safety Standard](#), Texas Instruments (2015).
2. [AMC1306 Datasheet](#)

## Additional resources

- Explore TI's [wide motor drive systems portfolio](#), with many options designed especially for lower voltages.
- Learn more about [designing for high-efficiency power and motor drive applications](#).

**Important Notice:** The products and services of Texas Instruments Incorporated and its subsidiaries described herein are sold subject to TI's standard terms and conditions of sale. Customers are advised to obtain the most current and complete information about TI products and services before placing orders. TI assumes no liability for applications assistance, customer's applications or product designs, software performance, or infringement of patents. The publication of information regarding any other company's products or services does not constitute TI's approval, warranty or endorsement thereof.

The platform bar, C2000, Delfino, and InstaSPIN are trademarks of Texas Instruments. All other trademarks are the property of their respective owners.



## IMPORTANT NOTICE FOR TI DESIGN INFORMATION AND RESOURCES

Texas Instruments Incorporated ("TI") technical, application or other design advice, services or information, including, but not limited to, reference designs and materials relating to evaluation modules, (collectively, "TI Resources") are intended to assist designers who are developing applications that incorporate TI products; by downloading, accessing or using any particular TI Resource in any way, you (individually or, if you are acting on behalf of a company, your company) agree to use it solely for this purpose and subject to the terms of this Notice.

TI's provision of TI Resources does not expand or otherwise alter TI's applicable published warranties or warranty disclaimers for TI products, and no additional obligations or liabilities arise from TI providing such TI Resources. TI reserves the right to make corrections, enhancements, improvements and other changes to its TI Resources.

You understand and agree that you remain responsible for using your independent analysis, evaluation and judgment in designing your applications and that you have full and exclusive responsibility to assure the safety of your applications and compliance of your applications (and of all TI products used in or for your applications) with all applicable regulations, laws and other applicable requirements. You represent that, with respect to your applications, you have all the necessary expertise to create and implement safeguards that (1) anticipate dangerous consequences of failures, (2) monitor failures and their consequences, and (3) lessen the likelihood of failures that might cause harm and take appropriate actions. You agree that prior to using or distributing any applications that include TI products, you will thoroughly test such applications and the functionality of such TI products as used in such applications. TI has not conducted any testing other than that specifically described in the published documentation for a particular TI Resource.

You are authorized to use, copy and modify any individual TI Resource only in connection with the development of applications that include the TI product(s) identified in such TI Resource. NO OTHER LICENSE, EXPRESS OR IMPLIED, BY ESTOPPEL OR OTHERWISE TO ANY OTHER TI INTELLECTUAL PROPERTY RIGHT, AND NO LICENSE TO ANY TECHNOLOGY OR INTELLECTUAL PROPERTY RIGHT OF TI OR ANY THIRD PARTY IS GRANTED HEREIN, including but not limited to any patent right, copyright, mask work right, or other intellectual property right relating to any combination, machine, or process in which TI products or services are used. Information regarding or referencing third-party products or services does not constitute a license to use such products or services, or a warranty or endorsement thereof. Use of TI Resources may require a license from a third party under the patents or other intellectual property of the third party, or a license from TI under the patents or other intellectual property of TI.

TI RESOURCES ARE PROVIDED "AS IS" AND WITH ALL FAULTS. TI DISCLAIMS ALL OTHER WARRANTIES OR REPRESENTATIONS, EXPRESS OR IMPLIED, REGARDING TI RESOURCES OR USE THEREOF, INCLUDING BUT NOT LIMITED TO ACCURACY OR COMPLETENESS, TITLE, ANY EPIDEMIC FAILURE WARRANTY AND ANY IMPLIED WARRANTIES OF MERCHANTABILITY, FITNESS FOR A PARTICULAR PURPOSE, AND NON-INFRINGEMENT OF ANY THIRD PARTY INTELLECTUAL PROPERTY RIGHTS.

TI SHALL NOT BE LIABLE FOR AND SHALL NOT DEFEND OR INDEMNIFY YOU AGAINST ANY CLAIM, INCLUDING BUT NOT LIMITED TO ANY INFRINGEMENT CLAIM THAT RELATES TO OR IS BASED ON ANY COMBINATION OF PRODUCTS EVEN IF DESCRIBED IN TI RESOURCES OR OTHERWISE. IN NO EVENT SHALL TI BE LIABLE FOR ANY ACTUAL, DIRECT, SPECIAL, COLLATERAL, INDIRECT, PUNITIVE, INCIDENTAL, CONSEQUENTIAL OR EXEMPLARY DAMAGES IN CONNECTION WITH OR ARISING OUT OF TI RESOURCES OR USE THEREOF, AND REGARDLESS OF WHETHER TI HAS BEEN ADVISED OF THE POSSIBILITY OF SUCH DAMAGES.

You agree to fully indemnify TI and its representatives against any damages, costs, losses, and/or liabilities arising out of your non-compliance with the terms and provisions of this Notice.

This Notice applies to TI Resources. Additional terms apply to the use and purchase of certain types of materials, TI products and services. These include; without limitation, TI's standard terms for semiconductor products (<http://www.ti.com/sc/docs/stdterms.htm>), [evaluation modules](#), and [samples \(http://www.ti.com/sc/docs/sampterm.htm\)](http://www.ti.com/sc/docs/sampterm.htm).

Mailing Address: Texas Instruments, Post Office Box 655303, Dallas, Texas 75265  
Copyright © 2017, Texas Instruments Incorporated