

How Capacitive Isolation Solves Key Challenges in AC Motor Drives



Nagarajan Sridhar

Power Solutions

Sean Alvarado

Power Solutions

Lucas Schulte

Interface Products

Anthony Viviano

Interface Products

Krunal Maniar

Data Converters

Texas Instruments

Signal and power isolation help ensure reliable operation of AC motor drive systems and protect human operators from high voltages.

Not all isolation technologies are created equal, however, especially in terms of device lifetime and temperature performance.

This white paper compares Texas Instruments' (TI) capacitive-based isolation technology with traditional isolation technology when solving alternating current (AC) motor design challenges, including isolating gate drivers in the power stage, isolating voltage or current feedback, or isolating digital inputs in the control module.

What is an AC motor drive system?

An AC motor drive is a system that uses an AC input to an induction motor, as shown in **Figure 1**, to drive large industrial loads such as heating, ventilation and air conditioning for commercial buildings, pumps and compressors. AC motors also drive factory automation and industrial equipment loads that require provisions to adjust speed, such as conveyor belts, or tunnel boring, mining and paper mill equipment.

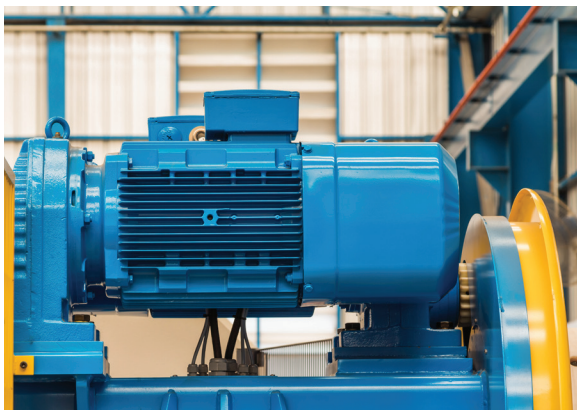

Figure 1. Induction motor with an AC motor drive in a factory.

An AC motor drive takes an AC energy source, rectifies it to a DC bus voltage and, implementing complex control algorithms, inverts the DC back to AC into the motor via complex control algorithms based on load demand.

Figure 2 is a block diagram of an AC motor drive, with the power stage and power supplies marked in green.

Isolation in AC motor drives

Electric motor drive systems such as AC motor drives involve high voltages and power levels; thus, it is imperative to take measures to protect both human operators and critical components throughout the system.

Additionally, critical system components such as controllers and communication peripherals also require protection from the high-power and high-voltage circuitry in the motor drive. It is possible to achieve insulation between circuits, as defined by the International Electrotechnical Commission 61800-5-1 safety standard, by isolating at the component level through a semiconductor integrated circuit (IC).

Isolated ICs enable the transfer of data and power between the high- and low-voltage units, while preventing any hazardous DC or uncontrolled transient current. Isolators typically provide this required level of insulation within a circuit through an isolation barrier, which separates the high voltage from parts accessible to humans. More information

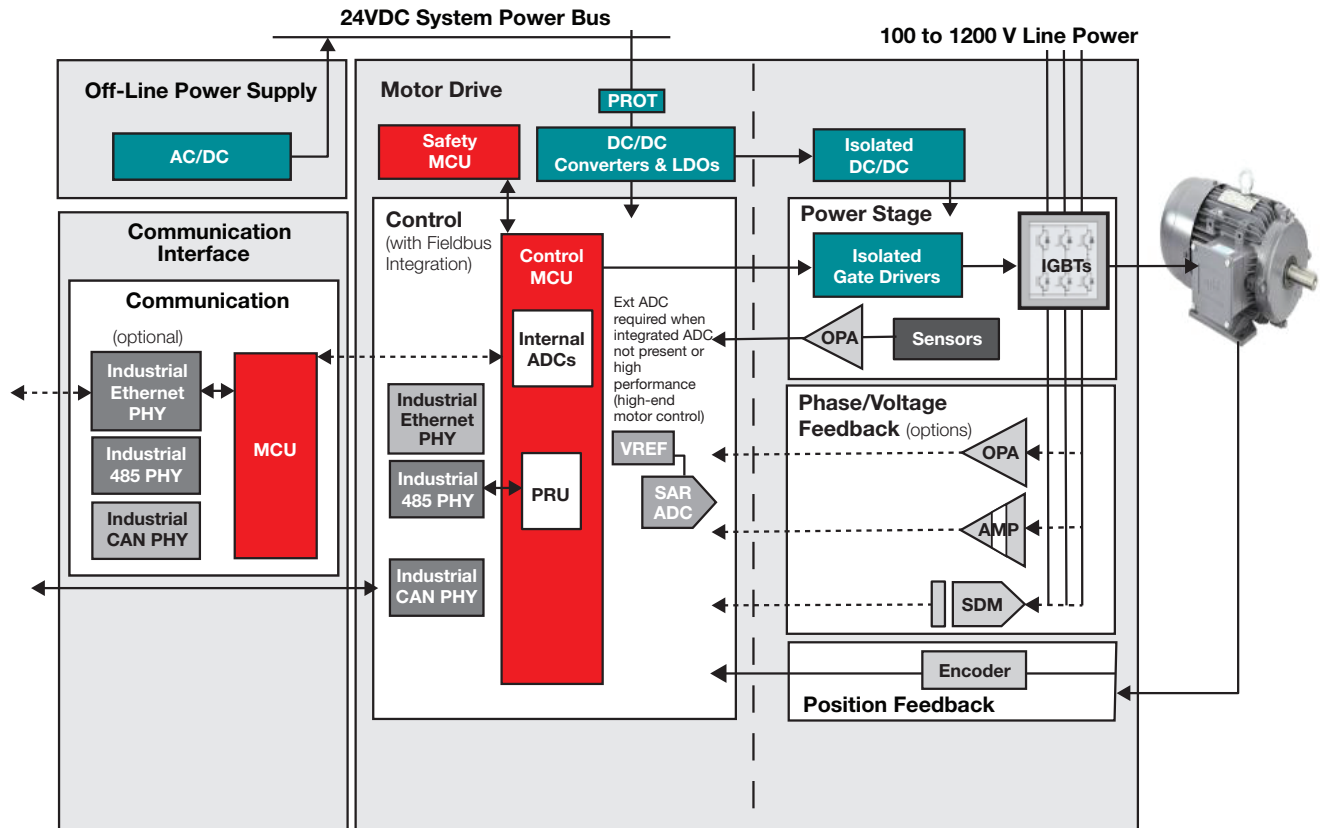

Figure 2. Block diagram of an AC motor drive.

on the IEC 61800-5-1 safety standard is available in the white paper, “[Isolation in AC Motor Drives: Understanding the IEC 61800-5-1 Safety Standard.](#)”

Implementing isolation in AC motor drives

Designers have multiple options for implementing an isolation barrier in AC motor drives, but the most popular device for achieving galvanic isolation in a system in the past 40 years has been an optocoupler, also known as an optoisolator or photocoupler. While cost-effective and ubiquitous, optocouplers do not provide the same level of temperature performance or device lifetimes as newer approaches to isolation.

TI’s capacitive isolation technology incorporates reinforced signal isolation in a capacitive circuit that uses silicon dioxide (the basic on-chip insulation) for the dielectric. Unlike optocouplers, it is possible to integrate the isolation circuit on the same chip as other circuitry. Isolators manufactured through this process offer reliability, shock protection and reinforced isolation equivalent to two levels of basic isolation in a single package.

Learn more about TI’s innovative capacitor-based reinforced isolation in the white paper, “[Enabling high voltage signal isolation quality and reliability.](#)”

The following sections explore the three primary isolation-related design challenges for AC motor drive designs, while also highlighting the advantages of capacitive isolation versus optocouplers.

Isolating gate drivers in the power stage

The power converter topology used in the power stage of an AC motor drive is a three-phase inverter topology transferring power in the kilowatt to megawatt range. These inverters convert DC power to AC power. Typical DC bus voltage levels are 600 V-1,200 V. The three-phase inverter uses six isolated gate drivers to turn the power switches (typically a bank of insulated gate bipolar transistors [IGBTs] or an IGBT module) on and off. Due to their superior properties, designers are beginning to employ wide-bandgap devices such as silicon carbide (SiC) metal-oxide semiconductor field-effect transistors (MOSFETs) or modules.

Each phase uses a high- and low-side IGBT switch, usually operating in the 20- to 30-kHz range, to apply positive and negative high-voltage DC pulses to the motor windings in alternating mode. Each IGBT or SiC module is driven by a single isolated gate driver. The isolation is galvanic between the high-voltage output of the gate driver and the low-voltage control inputs coming from the controller.

Gate drivers convert pulse-width modulation (PWM) signals from the controller into gate pulses for the field-effect transistors (FETs) or IGBTs. Moreover, these gate drivers need to have integrated protection features such as desaturation, active Miller clamping and soft turnoff.

Isolated gate drivers have two sides: the primary side, which is the input stage, and the secondary side, which interfaces with the FET. There are two types of input stages available on the primary side: voltage-based and current-based. It is through the input stage that the gate driver connects to the controller that tells the gate driver to turn on or off at a specified time.

Optocoupler gate drivers using a current-based input stage usually drive the IGBTs in motor drive applications. Current-based input stages tend to have higher noise immunity, and thus require a buffer stage between the controller and optocoupler. Power dissipation is also typically higher with current-based input stage drivers using the buffer stage.

Traditional optocoupler gate drivers do have some challenges:

- The LED in the input stage can degrade over time, which will affect device lifetimes and may result in longer propagation delays, impacting system performance.
- Their lower common-mode transient immunity (CMTI) limits how fast the power FETs can switch.
- They usually only support a lower operating temperature range, which makes it difficult to create more compact designs.

TI offers isolated gate drivers that use capacitive isolation technology to help overcome some of the common design challenges seen with optocouplers.

Figure 3 shows a comparison between traditional optocoupler gate drivers and TI's isolated gate drivers that use capacitive isolation. TI's capacitively isolated gate drivers have higher CMTI ratings, a wider operating temperature range and improved timing specifications such as part-to-part skew and propagation delay. To learn more about the CMTI performance of TI's gate drivers, read the application note, "[Common Mode Transient Immunity for Isolated Gate Drivers](#)."

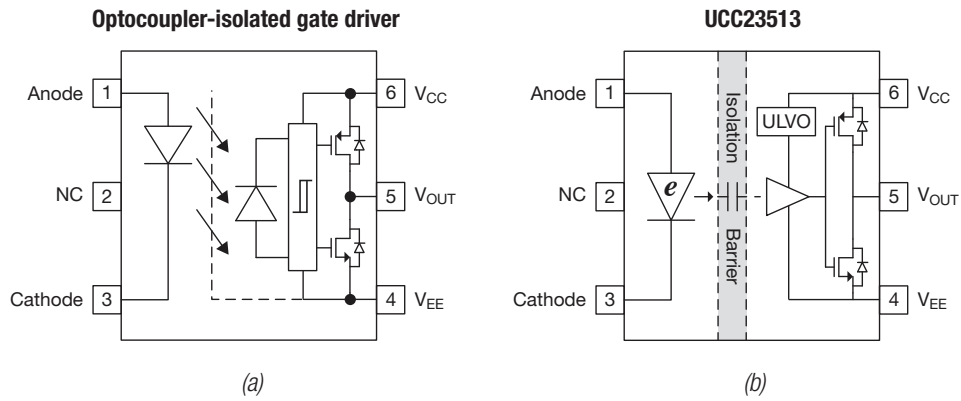

Figure 3. Comparison of optocoupler-isolated gate driver (a) and capacitively isolated gate driver (b).

Isolating current and voltage feedback

An AC motor drive uses a closed-loop control system comprising voltage and current feedback measurements to control the speed and torque of an AC motor. Because voltage and current feedback are measured on the high-voltage side, the signals must be isolated from the low-voltage controller side.

In-line phase currents measured on each of the three phases of the motor are used to derive the optimal PWM pattern to control the IGBTs. The accuracy, noise, bandwidth, latency and CMTI of these in-line phase current measurements directly impact the torque and speed output profiles of the motor.

Capacitively coupled isolated amplifiers and modulators, as shown in **Figure 4**, have fewer signal propagation delays, better CMTI and better lifetime and overtemperature reliability than optically coupled counterparts.

The application note, "[Comparing shunt- and Hall-based isolated current-sensing solutions in HEV/EV](#)" provides a detailed comparison in terms of isolation ratings, accuracy, temperature range, bandwidth and noise between shunt- and Hall-based current sensing methods.

Figure 5 is a typical block diagram of a feedback sensing loop using isolated amplifiers for shunt-based current sensing and resistor-divider-based voltage sensing. Phase current measurement is accomplished through the shunt resistors, R_{SHUNT} .

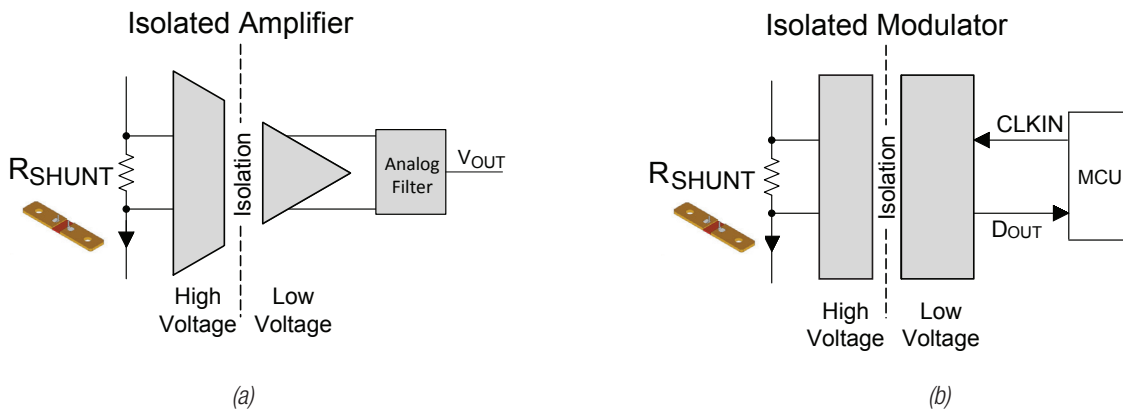

Figure 4. Examples of an isolated amplifier (a); and isolated modulator (b).

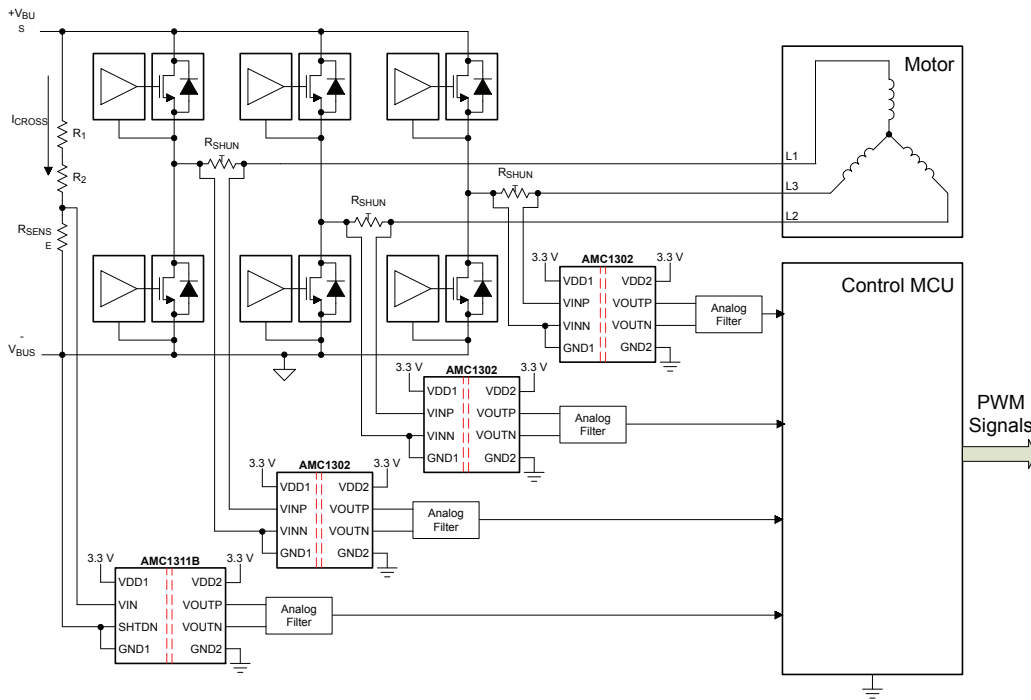

Figure 5. Typical current and voltage feedback implementation.

Compared to optocouplers, TI's isolated amplifiers support a very small bidirectional input voltage range with high CMTI and overall accuracy. These features enable reliable current sensing in high-noise motor drive environments. The high-impedance input and wide input voltage range of these devices make them a good fit for DC-link bus voltage sensing.

Isolating digital inputs in the control module

The control module in an AC motor drive is responsible for the signal processing and overall control algorithms for the motor drive system based on inputs from the position feedback module, analog inputs and digital inputs. These digital inputs are usually 24-V signals from field sensors and

switches communicating emergency stop signals, such as safe torque off (STO), or information about the motor's operation, such as speed and position.

When used with control algorithms, these digital signal inputs then make any necessary adjustments to the power stage in order to achieve the target output. Isolating the digital inputs from the control module prevents ground potential differences from causing communication errors.

While optocouplers have been used to isolate digital inputs, recent developments in digital isolator technology have revolutionized how system designers are engineering their digital inputs.

Figure 6, shows a common optocoupler solution for an isolated digital input that uses several discrete components (nine to 15) to implement a current

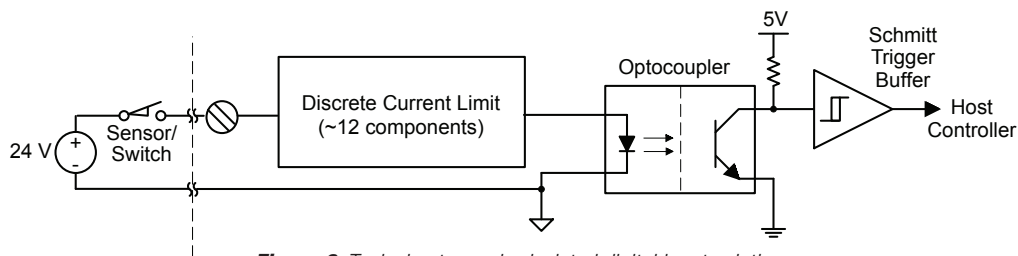

Figure 6. Typical optocoupler-isolated digital input solution.

limit and controlled voltage thresholds. Using this complex solution, the current limit is much higher than the target current limit of 2 mA, and can be as high as 6 mA across temperature, depending on the design. Additionally, a Schmitt trigger buffer after the optocoupler provides hysteresis for noise immunity.

Figure 7 shows a simplified solution, a specialized digital isolator meant for digital input applications. Devices with TI's capacitive isolation technology can achieve a current limit of <2.5 mA. The solution does not require a Schmitt trigger for noise immunity and needs only two resistors (R_{SENSE} and R_{THR}) to set the chosen current limit and voltage thresholds.

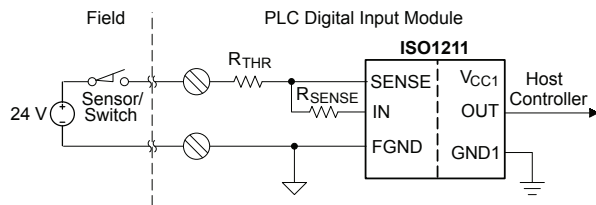

Figure 7. Isolated digital input solution using a TI digital isolator.

Compared to optocouplers, a capacitive-based approach to digital isolation has the advantage of much lower power dissipation. The precise current limit of TI digital isolators can reduce the current drawn from digital inputs by a factor of five, significantly reducing power dissipation and board temperature. Other features include a two-channel option with channel-to-channel isolation

to help reduce board space while also providing low propagation delay and a 4 Mbps data rate to support STO inputs. Supporting STO inputs with optocouplers requires high-speed optocouplers, which can be expensive and have shorter lifetimes than capacitor-based digital isolation technologies. More detailed information on the benefits of TI's isolated digital inputs in motor drive systems is available in the application note, "[How to Improve Speed and Reliability of Isolated Inputs in Motor Drives.](#)"

Summary

Whether you are isolating gate drivers in the power stage, isolating voltage or current feedback, or isolating digital inputs in the control module, TI's capacitive-based isolation technology revolutionizes the lifetime and temperature demands in AC motor drives, and in many cases provides a more compact solution than optocouplers.

For more information

- [View TI's diverse isolation portfolio](#)
- [Explore the features and benefits of TI's capacitive isolation technology](#)
- Learn more about [UCC23513](#), [AMC1302](#) and [ISO1211](#)

Important Notice: The products and services of Texas Instruments Incorporated and its subsidiaries described herein are sold subject to TI's standard terms and conditions of sale. Customers are advised to obtain the most current and complete information about TI products and services before placing orders. TI assumes no liability for applications assistance, customer's applications or product designs, software performance, or infringement of patents. The publication of information regarding any other company's products or services does not constitute TI's approval, warranty or endorsement thereof.

The platform bar is a trademark of Texas Instruments.
All other trademarks are the property of their respective owners.

B011617

IMPORTANT NOTICE AND DISCLAIMER

TI PROVIDES TECHNICAL AND RELIABILITY DATA (INCLUDING DATASHEETS), DESIGN RESOURCES (INCLUDING REFERENCE DESIGNS), APPLICATION OR OTHER DESIGN ADVICE, WEB TOOLS, SAFETY INFORMATION, AND OTHER RESOURCES "AS IS" AND WITH ALL FAULTS, AND DISCLAIMS ALL WARRANTIES, EXPRESS AND IMPLIED, INCLUDING WITHOUT LIMITATION ANY IMPLIED WARRANTIES OF MERCHANTABILITY, FITNESS FOR A PARTICULAR PURPOSE OR NON-INFRINGEMENT OF THIRD PARTY INTELLECTUAL PROPERTY RIGHTS.

These resources are intended for skilled developers designing with TI products. You are solely responsible for (1) selecting the appropriate TI products for your application, (2) designing, validating and testing your application, and (3) ensuring your application meets applicable standards, and any other safety, security, or other requirements. These resources are subject to change without notice. TI grants you permission to use these resources only for development of an application that uses the TI products described in the resource. Other reproduction and display of these resources is prohibited. No license is granted to any other TI intellectual property right or to any third party intellectual property right. TI disclaims responsibility for, and you will fully indemnify TI and its representatives against, any claims, damages, costs, losses, and liabilities arising out of your use of these resources.

TI's products are provided subject to TI's Terms of Sale (www.ti.com/legal/termsofsale.html) or other applicable terms available either on ti.com or provided in conjunction with such TI products. TI's provision of these resources does not expand or otherwise alter TI's applicable warranties or warranty disclaimers for TI products.

Mailing Address: Texas Instruments, Post Office Box 655303, Dallas, Texas 75265
Copyright © 2019, Texas Instruments Incorporated