

DRV8300U: 100V Three-Phase BLDC Gate Driver

1 Features

- 100V Three Phase Half-Bridge Gate driver
 - Drives N-Channel MOSFETs (NMOS)
 - Gate Driver Supply (GVDD): 5-20V
 - MOSFET supply (SHx) support up to 100V
- Integrated Bootstrap Diodes (DRV8300UD devices)
- Supports Inverting and Non-Inverting INLx inputs
- Bootstrap gate drive architecture
 - 750mA source current
 - 1.5A sink current
- Supports up to 15S battery powered applications
- Higher BSTUV (8V typ) and GVDDUV (7.6V typ) threshold to support standard MOSFETs
- Low leakage current on SHx pins (<55µA)
- Absolute maximum BSTx voltage up to 125V
- Supports negative transients up to -22V on SHx
- Built-in cross conduction prevention
- Adjustable deadtime through DT pin for QFN package variants
- Fixed deadtime insertion of 200nS for TSSOP package variants
- Supports 3.3V and 5V logic inputs with 20V Abs max
- 4nS typical propagation delay matching
- Compact QFN and TSSOP packages
- Efficient system design with [Power Blocks](#)
- Integrated protection features
 - BST undervoltage lockout (BSTUV)
 - GVDD undervoltage (GVDDUV)

2 Applications

- [E-Bikes, E-Scooters, and E-Mobility](#)
- [Fans, Pumps, and Servo Drives](#)
- [Brushless-DC \(BLDC\) Motor Modules and PMSM](#)
- [Cordless Garden and Power Tools, Lawnmowers](#)
- [Cordless Vacuum Cleaners](#)
- [Drones, Robotics, and RC Toys](#)
- [Industrial and Logistics Robots](#)

3 Description

DRV8300U is 100V three half-bridge gate drivers, capable of driving high-side and low-side N-channel power MOSFETs. The DRV8300UD generates the correct gate drive voltages using an integrated bootstrap diode and external capacitor for the high-side MOSFETs. GVDD is used to generate gate drive voltage for the low-side MOSFETs. The Gate Drive architecture supports peak up to 750mA source and 1.5A sink currents.

The phase pins SHx is able to tolerate the significant negative voltage transients; while high side gate driver supply BSTx and GHx is able to support to higher positive voltage transients (125V) abs max voltage which improves robustness of the system. Small propagation delay and delay matching specifications minimize the dead-time requirement which further improves efficiency. Undervoltage protection is provided for both low and high side through GVDD and BST undervoltage lockout.

Device Information (1)

PART NUMBER	PACKAGE	PACKAGE SIZE (NOM) ⁽²⁾
DRV8300UDPW	TSSOP (20)	6.50mm × 6.40mm
DRV8300UDIPW	TSSOP (20)	6.50mm × 6.40mm
DRV8300UDRGE	VQFN (24)	4.00mm × 4.00mm

- (1) For all available packages, see the orderable addendum at the end of the data sheet.
- (2) The package size (length × width) is a nominal value and includes pins, where applicable

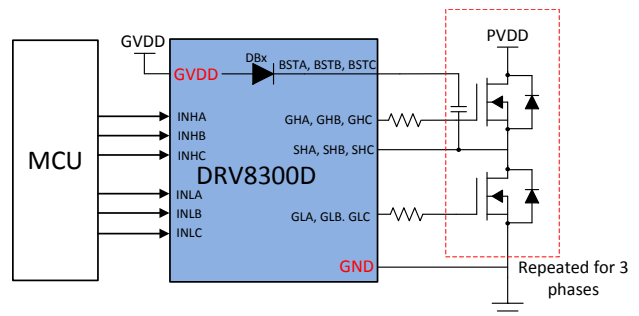

Simplified Schematic for DRV8300UD



Table of Contents

1 Features	1	7.3 Feature Description.....	13
2 Applications	1	7.4 Device Functional Modes.....	15
3 Description	1	8 Application and Implementation	16
4 Device Comparison Table	3	8.1 Application Information.....	16
5 Pin Configuration and Functions	4	8.2 Typical Application.....	17
6 Specifications	6	8.3 Power Supply Recommendations.....	19
6.1 Absolute Maximum Ratings.....	6	8.4 Layout.....	19
6.2 ESD Ratings Comm.....	6	9 Device and Documentation Support	21
6.3 Recommended Operating Conditions.....	6	9.1 Receiving Notification of Documentation Updates....	21
6.4 Thermal Information.....	7	9.2 Support Resources.....	21
6.5 Electrical Characteristics.....	7	9.3 Trademarks.....	21
6.6 Timing Diagrams.....	9	9.4 Electrostatic Discharge Caution.....	21
6.7 Typical Characteristics.....	9	9.5 Glossary.....	21
7 Detailed Description	11	10 Revision History	21
7.1 Overview.....	11	11 Mechanical, Packaging, and Orderable Information	21
7.2 Functional Block Diagram.....	12		

4 Device Comparison Table

Device Variants	Package	Integrated Bootstrap Diode	GLx polarity with Respect to INLx Input	Deadtime
DRV8300UD	20-Pin TSSOP	Yes	Non-Inverted	Fixed
DRV8300UDI		Yes	Inverted	Fixed
DRV8300UD	24-Pin VQFN	Yes	Non-Inverted or Inverted	Variable

Table 4-1. DRV8300 vs DRV8300U comparison

Parameters	DRV8300	DRV8300U
GVDDUV rising	4.6V (typ)	8.3V (typ)
GVDDUV falling	4.35V (typ)	8V (typ)
BSTUV rising	4.2V (typ)	8V (typ)
BSTUV falling	4V (typ)	7.6V(typ)

5 Pin Configuration and Functions

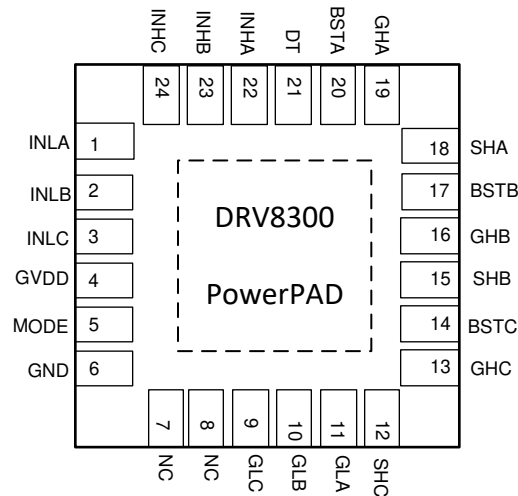

Figure 5-1. DRV8300UD RGE Package 24-Pin VQFN With Exposed Thermal Pad Top View

Table 5-1. Pin Functions—24-Pin DRV8300U Devices

PIN		TYPE ⁽¹⁾	DESCRIPTION
NAME	NO.		
BSTA	20	O	Bootstrap output pin. Connect capacitor between BSTA and SHA
BSTB	17	O	Bootstrap output pin. Connect capacitor between BSTB and SHB
BSTC	14	O	Bootstrap output pin. Connect capacitor between BSTC and SHC
DT	21	I	Deadtime input pin. Connect resistor to ground for variable deadtime, fixed deadtime when left floating
GHA	19	O	High-side gate driver output. Connect to the gate of the high-side power MOSFET.
GHB	16	O	High-side gate driver output. Connect to the gate of the high-side power MOSFET.
GHC	13	O	High-side gate driver output. Connect to the gate of the high-side power MOSFET.
GLA	11	O	Low-side gate driver output. Connect to the gate of the low-side power MOSFET.
GLB	10	O	Low-side gate driver output. Connect to the gate of the low-side power MOSFET.
GLC	9	O	Low-side gate driver output. Connect to the gate of the low-side power MOSFET.
INHA	22	I	High-side gate driver control input. This pin controls the output of the high-side gate driver.
INHB	23	I	High-side gate driver control input. This pin controls the output of the high-side gate driver.
INHC	24	I	High-side gate driver control input. This pin controls the output of the high-side gate driver.
INLA	1	I	Low-side gate driver control input. This pin controls the output of the low-side gate driver.
INLB	2	I	Low-side gate driver control input. This pin controls the output of the low-side gate driver.
INLC	3	I	Low-side gate driver control input. This pin controls the output of the low-side gate driver.
MODE	5	I	Mode Input controls polarity of GLx compared to INLx inputs. Mode pin floating: GLx output polarity same(Non-Inverted) as INLx input Mode pin to GVDD: GLx output polarity inverted compared to INLx input
NC	7, 8	NC	No internal connection. This pin can be left floating or connected to system ground.
GND	6	PWR	Device ground.
SHA	18	I	High-side source sense input. Connect to the high-side power MOSFET source.
SHB	15	I	High-side source sense input. Connect to the high-side power MOSFET source.
SHC	12	I	High-side source sense input. Connect to the high-side power MOSFET source.
GVDD	4	PWR	Gate driver power supply input. Connect a X5R or X7R, GVDD-rated ceramic and greater than or equal to 10uF local capacitance between the GVDD and GND pins.

(1) PWR = power, I = input, O = output, NC = no connection

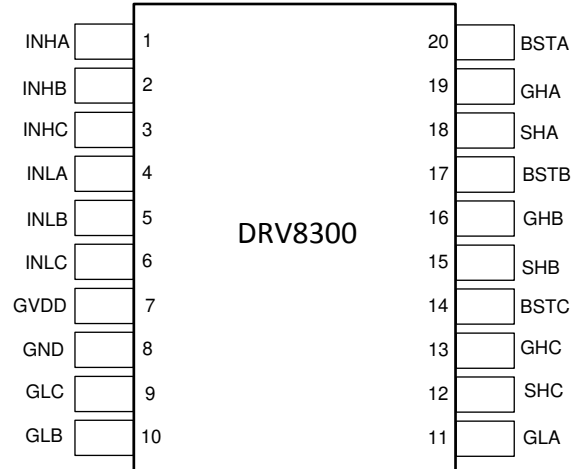

Figure 5-2. DRV8300UD, DRV8300UDI PW Package 20-Pin TSSOP Top View

Table 5-2. Pin Functions—20-Pin DRV8300U Devices

PIN		TYPE ¹	DESCRIPTION
NAME	NO.		
BSTA	20	O	Bootstrap output pin. Connect capacitor between BSTA and SHA
BSTB	17	O	Bootstrap output pin. Connect capacitor between BSTB and SHB
BSTC	14	O	Bootstrap output pin. Connect capacitor between BSTC and SHC
GHA	19	O	High-side gate driver output. Connect to the gate of the high-side power MOSFET.
GHB	16	O	High-side gate driver output. Connect to the gate of the high-side power MOSFET.
GHC	13	O	High-side gate driver output. Connect to the gate of the high-side power MOSFET.
GLA	11	O	Low-side gate driver output. Connect to the gate of the low-side power MOSFET.
GLB	10	O	Low-side gate driver output. Connect to the gate of the low-side power MOSFET.
GLC	9	O	Low-side gate driver output. Connect to the gate of the low-side power MOSFET.
INHA	1	I	High-side gate driver control input. This pin controls the output of the high-side gate driver.
INHB	2	I	High-side gate driver control input. This pin controls the output of the high-side gate driver.
INHC	3	I	High-side gate driver control input. This pin controls the output of the high-side gate driver.
INLA	4	I	Low-side gate driver control input. This pin controls the output of the low-side gate driver.
INLB	5	I	Low-side gate driver control input. This pin controls the output of the low-side gate driver.
INLC	6	I	Low-side gate driver control input. This pin controls the output of the low-side gate driver.
GND	8	PWR	Device ground.
SHA	18	I	High-side source sense input. Connect to the high-side power MOSFET source.
SHB	15	I	High-side source sense input. Connect to the high-side power MOSFET source.
SHC	12	I	High-side source sense input. Connect to the high-side power MOSFET source.
GVDD	7	PWR	Gate driver power supply input. Connect a X5R or X7R, GVDD-rated ceramic and greater than or equal to 10uF local capacitance between the GVDD and GND pins.

1. PWR = power, I = input, O = output, NC = no connection

6 Specifications

6.1 Absolute Maximum Ratings

over operating temperature range (unless otherwise noted)⁽¹⁾

		MIN	MAX	UNIT
Gate driver regulator pin voltage	GVDD	-0.3	21.5	V
Bootstrap pin voltage	BSTx	-0.3	125	V
Bootstrap pin voltage	BSTx with respect to SHx	-0.3	21.5	V
Logic pin voltage	INHx, INLx, MODE, DT	-0.3	V _{GVDD} +0.3	V
High-side gate drive pin voltage	GHx	-22	125	V
High-side gate drive pin voltage	GHx with respect to SHx	-0.3	22	V
Transient 500-ns high-side gate drive pin voltage	GHx with respect to SHx	-5	22	V
Low-side gate drive pin voltage	GLx	-0.3	V _{GVDD} +0.3	V
Transient 500-ns low-side gate drive pin voltage	GLx	-5	V _{GVDD} +0.3	V
High-side source pin voltage	SHx	-22	110	V
Ambient temperature, T _A		-40	125	°C
Junction temperature, T _J		-40	150	°C
Storage temperature, T _{stg}		-65	150	°C

- (1) Operation outside the Absolute Maximum Ratings may cause permanent device damage. Absolute Maximum Ratings do not imply functional operation of the device at these or any other conditions beyond those listed under Recommended Operating Conditions. If used outside the Recommended Operating Conditions but within the Absolute Maximum Ratings, the device may not be fully functional, and this may affect device reliability, functionality, performance, and shorten the device lifetime

6.2 ESD Ratings Comm

			VALUE	UNIT
V _(ESD)	Electrostatic discharge	Human body model (HBM), per ANSI/ESDA/JEDEC JS-001 ⁽¹⁾	±1000	V
		Charged device model (CDM), per JEDEC specification JESD22-C101 ⁽²⁾	±250	

- (1) JEDEC document JEP155 states that 500-V HBM allows safe manufacturing with a standard ESD control process.
 (2) JEDEC document JEP157 states that 250-V CDM allows safe manufacturing with a standard ESD control process.

6.3 Recommended Operating Conditions

over operating temperature range (unless otherwise noted)

			MIN	NOM	MAX	UNIT
V _{GVDD}	Power supply voltage	GVDD	8.7		20	V
V _{SHx}	High-side source pin voltage	SHx	-2		85	V
V _{SHx}	Transient 2μs high-side source pin voltage	SHx	-22		85	V
V _{BST}	Bootstrap pin voltage	BSTx	5		105	V
V _{BST}	Bootstrap pin voltage	BSTx with respect to SHx	5		20	V
V _{IN}	Logic input voltage	INHx, INLx, MODE, DT	0		GVDD	V
f _{PWM}	PWM frequency	INHx, INLx	0		200	kHz
V _{SHSL}	Slew rate on SHx pin (DRV8300UD and DRV8300UDI)				2	V/ns
C _{BOOT} ⁽¹⁾	Capacitor between BSTx and SHx (DRV8300UD and DRV8300UDI)				1	μF
T _A	Operating ambient temperature		-40		125	°C
T _J	Operating junction temperature		-40		150	°C

- (1) Current flowing through boot diode (D_{BOOT}) needs to be limited for C_{BOOT} > 1μF

6.4 Thermal Information

THERMAL METRIC ⁽¹⁾		DRV8300U		UNIT
		PW (TSSOP)	RGE (VQFN)	
		20 PINS	24 PINS	
R _{θJA}	Junction-to-ambient thermal resistance	97.4	49.3	°C/W
R _{θJC(top)}	Junction-to-case (top) thermal resistance	38.3	42.5	°C/W
R _{θJB}	Junction-to-board thermal resistance	48.8	26.5	°C/W
Ψ _{JT}	Junction-to-top characterization parameter	4.3	2.2	°C/W
Ψ _{JB}	Junction-to-board characterization parameter	48.4	26.4	°C/W
R _{θJC(bot)}	Junction-to-case (bottom) thermal resistance	N/A	11.5	°C/W

(1) For more information about traditional and new thermal metrics, see the [Semiconductor and IC Package Thermal Metrics](#) application report.

6.5 Electrical Characteristics

8.7 V ≤ V_{GVDD} ≤ 20 V, -40°C ≤ T_J ≤ 150°C (unless otherwise noted)

PARAMETER		TEST CONDITIONS	MIN	TYP	MAX	UNIT
POWER SUPPLIES (GVDD, BSTx)						
I _{GVDD}	GVDD standby mode current	INHx = INLx = 0; V _{BSTx} = V _{GVDD}	400	800	1400	μA
	GVDD active mode current	INHx = INLx = Switching @20kHz; V _{BSTx} = V _{GVDD} ; NO FETs connected	400	825	1400	μA
I _{BSx}	Bootstrap pin leakage current	V _{BSTx} = V _{SHx} = 85V; V _{GVDD} = 0V	2	4	7	μA
I _{BS_TRAN}	Bootstrap pin active mode transient leakage current	INHx = Switching@20kHz	30	105	220	μA
I _{BS_DC}	Bootstrap pin active mode leakage static current	INHx = High	30	85	150	μA
I _{SHx}	High-side source pin leakage current	INHx = INLx = 0; V _{BSTx} - V _{SHx} = 12V; V _{SHx} = 0 to 85V	30	55	80	μA
LOGIC-LEVEL INPUTS (INHx, INLx, MODE)						
V _{IL_MODE}	Input logic low voltage	Mode pin			0.6	V
V _{IL}	Input logic low voltage	INLx, INHx pins			0.8	V
V _{IH_MODE}	Input logic high voltage	Mode pin	3.7			V
V _{IH}	Input logic high voltage	INLx, INHx pins	2.0			V
V _{HYS_MODE}	Input hysteresis	Mode pin	1600	2000	2400	mV
V _{HYS}	Input hysteresis	INLx, INHx pins	40	100	260	mV
I _{IL_INLx}	INLx Input logic low current	V _{PIN} (Pin Voltage) = 0 V; INLx in non-inverting mode	-1	0	1	μA
		V _{PIN} (Pin Voltage) = 0 V; INLx in inverting mode	5	20	30	μA
I _{IH_INLx}	INLx Input logic high current	V _{PIN} (Pin Voltage) = 5 V; INLx in non-inverting mode	5	20	30	μA
		V _{PIN} (Pin Voltage) = 5 V; INLx in inverting mode	0	0.5	1.5	μA
I _{IL}	INHx, MODE Input logic low current	V _{PIN} (Pin Voltage) = 0 V;	-1	0	1	μA
I _{IH}	INHx, MODE Input logic high current	V _{PIN} (Pin Voltage) = 5 V;	5	20	30	μA
R _{PD_INHx}	INHx Input pulldown resistance	To GND	120	200	280	kΩ
R _{PD_INLx}	INLx Input pulldown resistance	To GND, INLx in non-inverting mode	120	200	280	kΩ
R _{PU_INLx}	INLx Input pullup resistance	To INT_5V, INLx in inverting mode	120	200	280	kΩ
R _{PD_MODE}	MODE Input pulldown resistance	To GND	120	200	280	kΩ
GATE DRIVERS (GHx, GLx, SHx, SLx)						

DRV8300U

SLVSGY3B – JULY 2022 – REVISED JUNE 2025

 $8.7\text{ V} \leq V_{\text{GVDD}} \leq 20\text{ V}$, $-40^\circ\text{C} \leq T_{\text{J}} \leq 150^\circ\text{C}$ (unless otherwise noted)

PARAMETER		TEST CONDITIONS	MIN	TYP	MAX	UNIT
$V_{\text{GHx_LO}}$	High-side gate drive low level voltage	$I_{\text{GLx}} = -100\text{ mA}$; $V_{\text{GVDD}} = 12\text{V}$; No FETs connected	0	0.15	0.35	V
$V_{\text{GHx_HI}}$	High-side gate drive high level voltage ($V_{\text{BSTx}} - V_{\text{GHx}}$)	$I_{\text{GHx}} = 100\text{ mA}$; $V_{\text{GVDD}} = 12\text{V}$; No FETs connected	0.3	0.6	1.2	V
$V_{\text{GLx_LO}}$	Low-side gate drive low level voltage	$I_{\text{GLx}} = -100\text{ mA}$; $V_{\text{GVDD}} = 12\text{V}$; No FETs connected	0	0.15	0.35	V
$V_{\text{GLx_HI}}$	Low-side gate drive high level voltage ($V_{\text{GVDD}} - V_{\text{GLx}}$)	$I_{\text{GHx}} = 100\text{ mA}$; $V_{\text{GVDD}} = 12\text{V}$; No FETs connected	0.3	0.6	1.2	V
$I_{\text{DRIVEP_HS}}$	High-side peak source gate current	$\text{GHx-SHx} = 12\text{V}$	400	750	1200	mA
$I_{\text{DRIVEN_HS}}$	High-side peak sink gate current	$\text{GHx-SHx} = 0\text{V}$	850	1500	2100	mA
$I_{\text{DRIVEP_LS}}$	Low-side peak source gate current	$\text{GLx} = 12\text{V}$	400	750	1200	mA
$I_{\text{DRIVEN_LS}}$	Low-side peak sink gate current	$\text{GLx} = 0\text{V}$	850	1500	2100	mA
t_{PD}	Input to output propagation delay	$\text{INHx, INLx to GHx, GLx}$; $V_{\text{GVDD}} = V_{\text{BSTx}} - V_{\text{SHx}} > 8\text{V}$; $\text{SHx} = 0\text{V}$, No load on GHx and GLx	70	125	180	ns
$t_{\text{PD_match}}$	Matching propagation delay per phase	GHx turning OFF to GLx turning ON, GLx turning OFF to GHx turning ON; $V_{\text{GVDD}} = V_{\text{BSTx}} - V_{\text{SHx}} > 8\text{V}$; $\text{SHx} = 0\text{V}$, No load on GHx and GLx	-30	± 4	30	ns
$t_{\text{PD_match}}$	Matching propagation delay phase to phase	GHx/GLx turning ON to GHy/GLy turning ON, GHx/GLx turning OFF to GHy/GLy turning OFF; $V_{\text{GVDD}} = V_{\text{BSTx}} - V_{\text{SHx}} > 8\text{V}$; $\text{SHx} = 0\text{V}$, No load on GHx and GLx	-30	± 4	30	ns
$t_{\text{R_GLx}}$	GLx rise time (10% to 90%)	$C_{\text{LOAD}} = 1000\text{ pF}$; $V_{\text{GVDD}} = V_{\text{BSTx}} - V_{\text{SHx}} > 8\text{V}$; $\text{SHx} = 0\text{V}$	10	24	50	ns
$t_{\text{R_GHx}}$	GHx rise time (10% to 90%)	$C_{\text{LOAD}} = 1000\text{ pF}$; $V_{\text{GVDD}} = V_{\text{BSTx}} - V_{\text{SHx}} > 8\text{V}$; $\text{SHx} = 0\text{V}$	10	24	50	ns
$t_{\text{F_GLx}}$	GLx fall time (90% to 10%)	$C_{\text{LOAD}} = 1000\text{ pF}$; $V_{\text{GVDD}} = V_{\text{BSTx}} - V_{\text{SHx}} > 8\text{V}$; $\text{SHx} = 0\text{V}$	5	12	30	ns
$t_{\text{F_GHx}}$	GHx fall time (90% to 10%)	$C_{\text{LOAD}} = 1000\text{ pF}$; $V_{\text{GVDD}} = V_{\text{BSTx}} - V_{\text{SHx}} > 8\text{V}$; $\text{SHx} = 0\text{V}$	5	12	30	ns
t_{DEAD}	Gate drive dead time	DT pin floating	150	215	280	ns
		DT pin connected to GND	150	215	280	ns
		40 k Ω between DT pin and GND	150	200	260	ns
		400 k Ω between DT pin and GND	1500	2000	2600	ns
$t_{\text{PW_MIN}}$	Minimum input pulse width on INHx, INLx that changes the output on GHx, GLx		40	70	150	ns
BOOTSTRAP DIODES(DRV8300UD, DRV8300UDI)						
V_{BOOTD}	Bootstrap diode forward voltage	$I_{\text{BOOT}} = 100\text{ }\mu\text{A}$	0.45	0.7	0.85	V
		$I_{\text{BOOT}} = 100\text{ mA}$	2	2.3	3.1	V
R_{BOOTD}	Bootstrap dynamic resistance ($\Delta V_{\text{BOOTD}}/\Delta I_{\text{BOOT}}$)	$I_{\text{BOOT}} = 100\text{ mA}$ and 80 mA	11	15	25	Ω
PROTECTION CIRCUITS						
V_{GVDDUV}	Gate Driver Supply undervoltage lockout (GVDDUV)	Supply rising	8	8.3	8.6	V
		Supply falling	7.8	8	8.25	V
$V_{\text{GVDDUV_HYS}}$	Gate Driver Supply UV hysteresis	Rising to falling threshold	295	330	360	mV
t_{GVDDUV}	Gate Driver Supply undervoltage deglitch time		5	10	13	μs

8.7 V ≤ V_{GVDD} ≤ 20 V, -40°C ≤ T_J ≤ 150°C (unless otherwise noted)

PARAMETER		TEST CONDITIONS	MIN	TYP	MAX	UNIT
V _{BSTUV}	Boot Strap undervoltage lockout (V _{BSTx} - V _{SHx})	Supply rising	7.5	8	8.7	V
	Boot Strap undervoltage lockout (V _{BSTx} - V _{SHx})	Supply falling	6.9	7.6	8.4	V
V _{BSTUV_HYS}	Bootstrap UV hysteresis	Rising to falling threshold	250	400	850	mV
t _{BSTUV}	Bootstrap undervoltage deglitch time		5.5	10	22	μs

6.6 Timing Diagrams

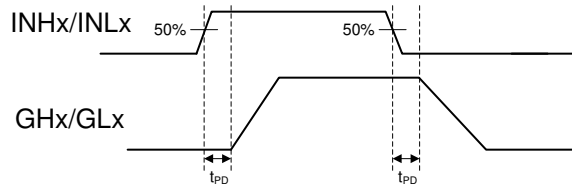

Figure 6-1. Propagation Delay (t_{PD})

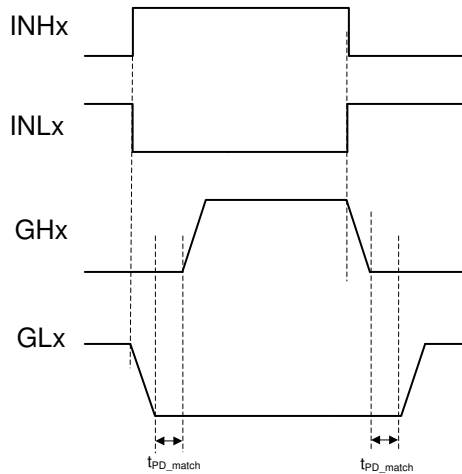

Figure 6-2. Propagation Delay Match (t_{PD_match})

6.7 Typical Characteristics

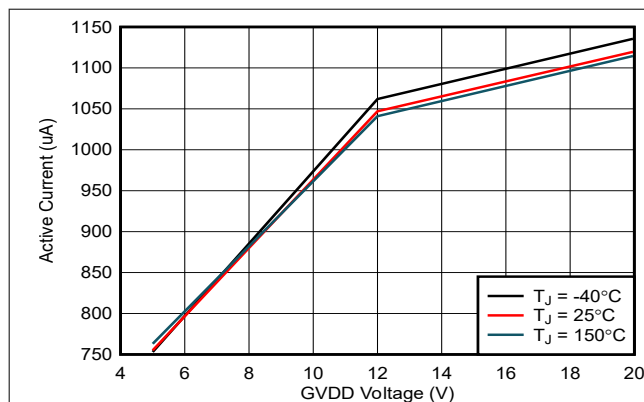

Figure 6-3. Supply Current Over GVDD Voltage

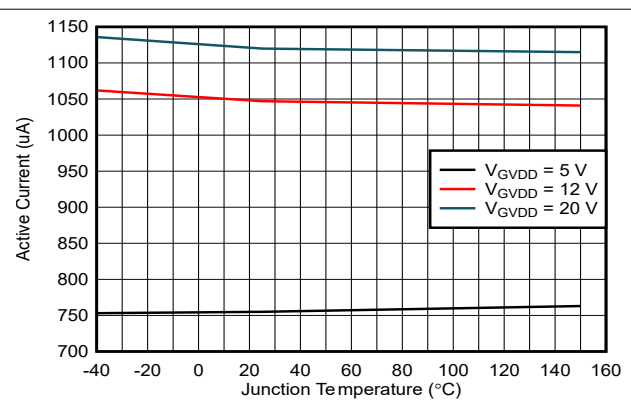

Figure 6-4. Supply Current Over Temperature

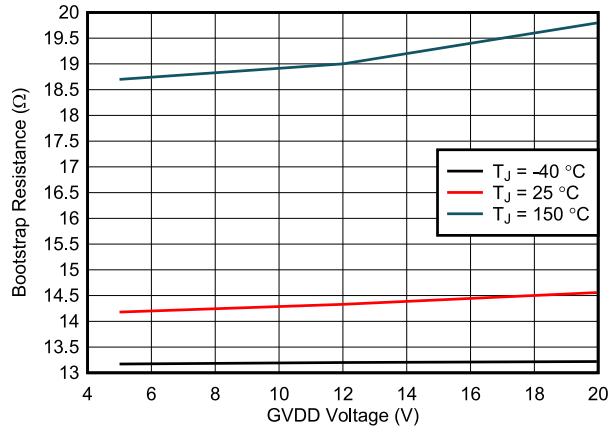

Figure 6-5. Bootstrap Resistance Over GVDD Voltage

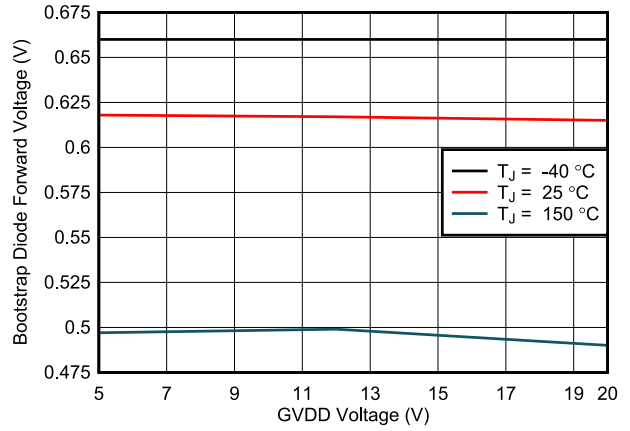

Figure 6-6. Bootstrap Diode Forward Voltage over GVDD Voltage

7 Detailed Description

7.1 Overview

The DRV8300U family of devices is a gate driver for three-phase motor drive applications. These devices decrease system component count, saves PCB space and cost by integrating three independent half-bridge gate drivers and optional bootstrap diodes.

DRV8300U supports external N-channel high-side and low-side power MOSFETs and can drive 750mA source, 1.5A sink peak currents with total combined 30mA average output current. The DRV8300U family of devices are available in 0.5mm pitch QFN and 0.65mm pitch TSSOP surface-mount packages. The QFN size is 4 × 4mm (0.5mm pin pitch) for the 24-pin package, and TSSOP body size is 6.5 × 4.4mm (0.65mm pin pitch) for the 20-pin package.

7.2 Functional Block Diagram

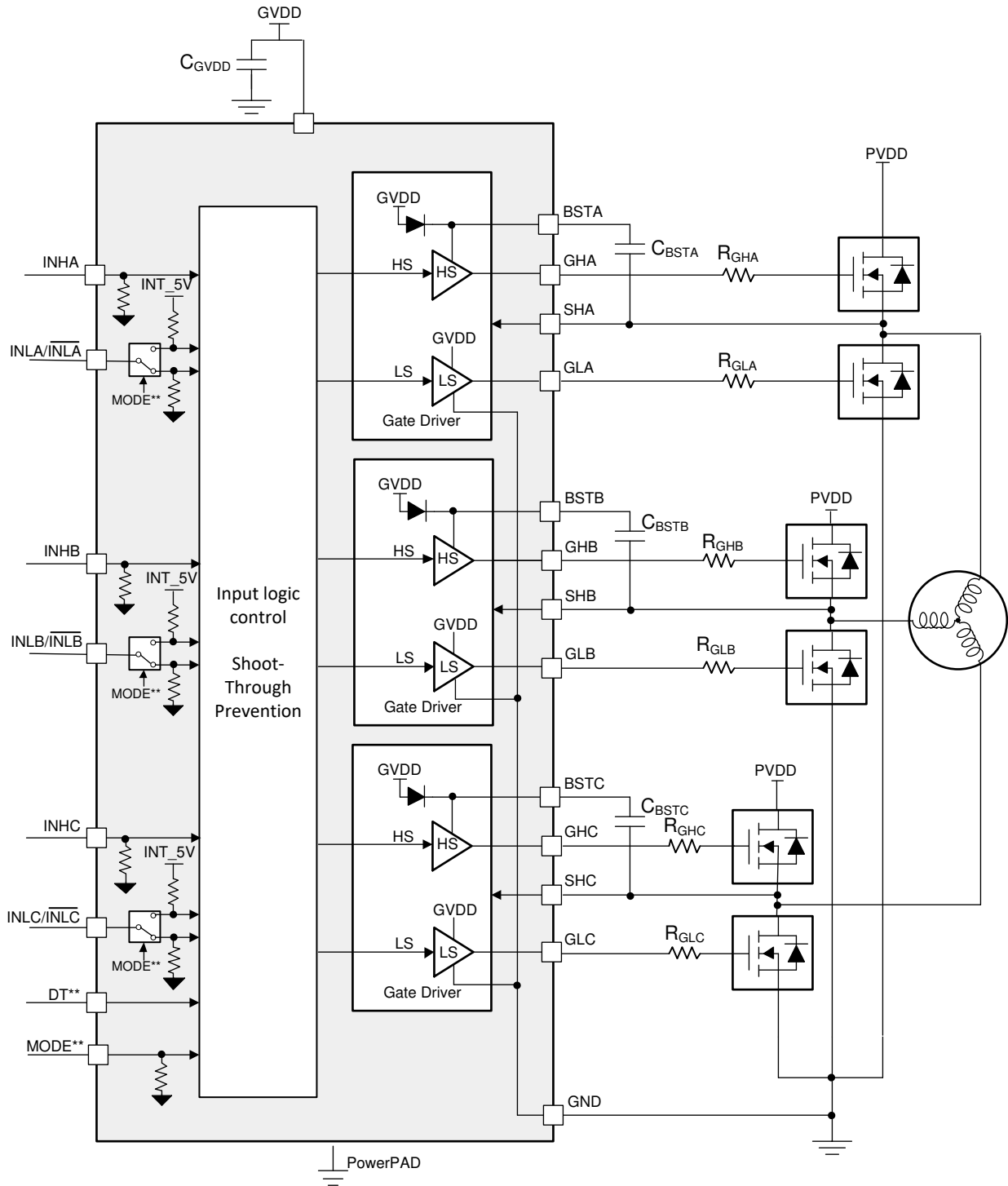

** QFN-24 Package

Figure 7-1. Block Diagram for DRV8300UD

7.3 Feature Description

7.3.1 Three BLDC Gate Drivers

The DRV8300U integrates three half-bridge gate drivers, each capable of driving high-side and low-side N-channel power MOSFETs. Input on GVDD provides the gate bias voltage for the low-side MOSFETs. The high voltage is generated using bootstrap capacitor and GVDD supply. The half-bridge gate drivers can be used in combination to drive a three-phase motor or separately to drive other types of loads.

7.3.1.1 Gate Drive Timings

7.3.1.1.1 Propagation Delay

The propagation delay time (t_{pd}) is measured as the time between an input logic edge to a detected output change. This time has two parts consisting of the input deglitcher delay and the delay through the analog gate drivers.

The input deglitcher prevents high-frequency noise on the input pins from affecting the output state of the gate drivers. The analog gate drivers have a small delay that contributes to the overall propagation delay of the device.

7.3.1.1.2 Deadtime and Cross-Conduction Prevention

In the DRV8300U, high-side and low-side inputs operate independently, with an exception to prevent cross conduction when high and low side are turned ON at same time. The DRV8300U turns OFF high-side and low-side output to prevent shoot through when the both high-side and low-side inputs are at logic HIGH at same time.

The DRV8300U also provides option to insert additional deadtime to prevent the external high-side and low-side MOSFET from switching on at the same time. In the devices with DT pin (QFN package), deadtime can be linearly adjusted between 200 ns to 2000 ns by configuring resistor value between DT and GND. When the DT pin is left floating, fixed deadtime of 200 ns (typical value) is inserted. The value of resistor can be calculated using [Equation 1](#).

$$R_{DT} (k\Omega) = \frac{\text{Deadtime (ns)}}{5} \quad (1)$$

In the devices without DT pin (TSSOP package), fixed deadtime of 200 ns (typical value) is inserted to prevent high and low side gate output turning ON at same time.

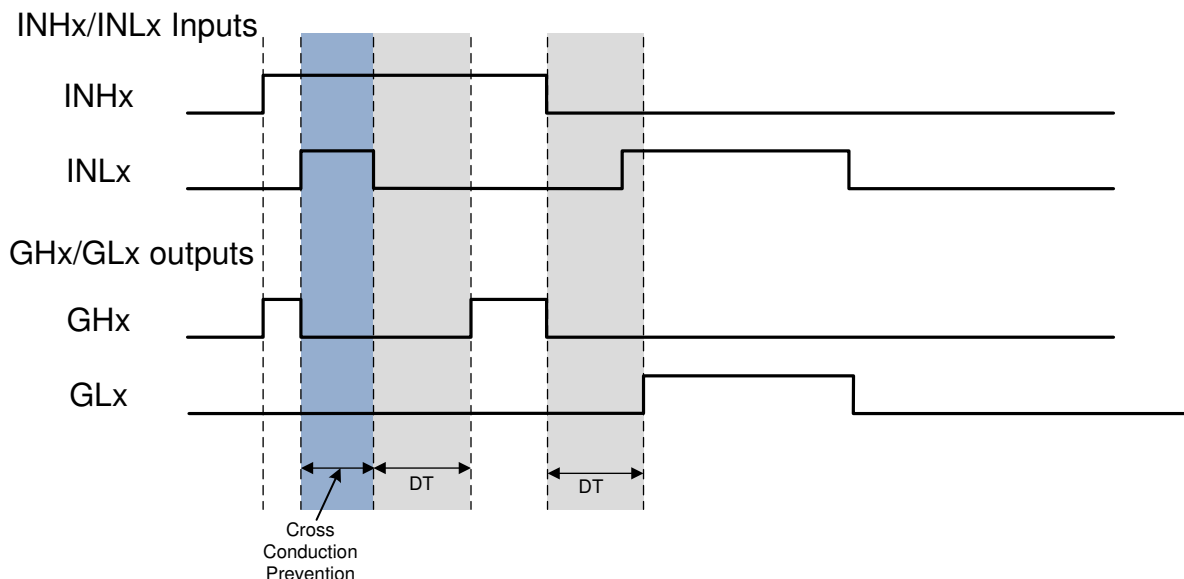

Figure 7-2. Cross Conduction Prevention and Deadtime Insertion

7.3.1.2 Mode (Inverting and non inverting INLx)

The DRV8300U has flexibility of accepting different kind of inputs on INLx. In the devices with MODE pin (QFN package), the DRV8300U provides option of configuring the GLx outputs to be inverted or non-inverted compared to polarity of signal on INLx pins. When the MODE pin is left floating, the INLx is configured to be in non-inverting mode and GLx output is in phase with respect to INLx (see [Figure 7-3](#)), whereas when the MODE pin is connected to GVDD, GLx output is out of phase with respect to INLx (see [Figure 7-4](#)). In devices without MODE pin (TSSOP package device), there are different device option available for inverting and non inverting inputs (see [Section 4](#)).

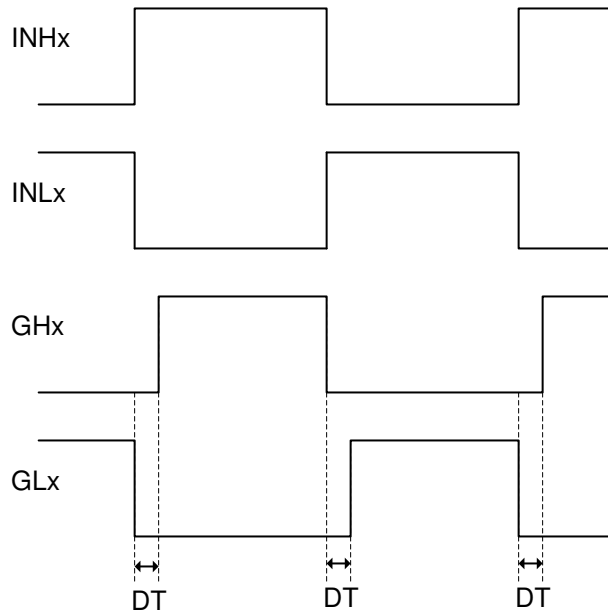

Figure 7-3. Non-Inverted INLx inputs

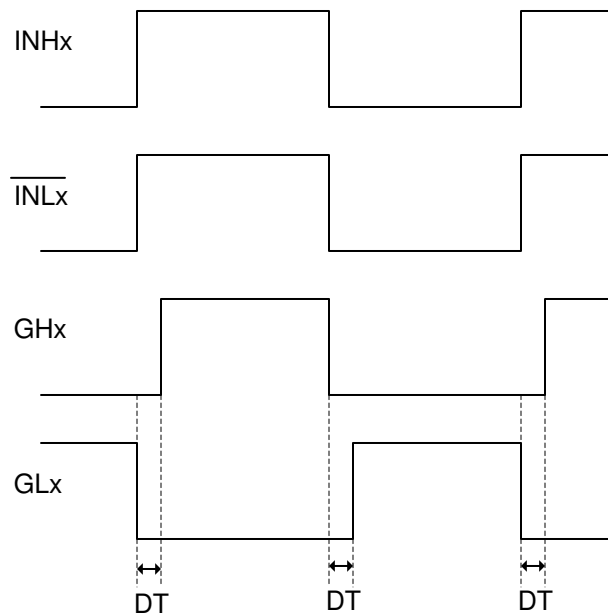
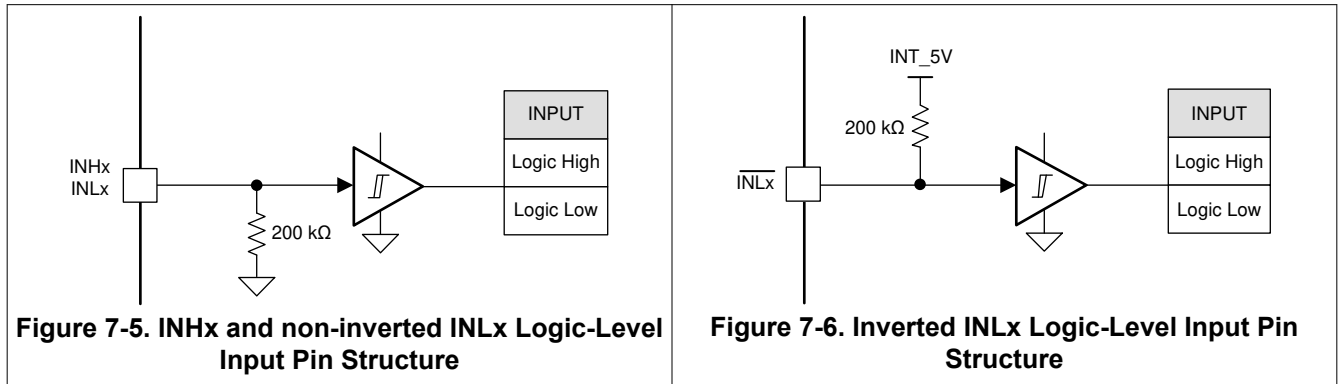

Figure 7-4. Inverted INLx inputs

7.3.2 Pin Diagrams

Figure 7-5 shows the input structure for the logic level pins INHx, INLx. INHx and non-inverted INLx has passive pull down, so when inputs are floating the output the gate driver is pulled low. Figure 7-6 shows the input structure for the inverted INLx pins. The inverted INLx has passive pull up, so when inputs are floating the output of the low-side gate driver is pulled low.



7.3.3 Gate Driver Protective Circuits

The DRV8300U is protected against BSTx undervoltage and GVDD undervoltage events.

Table 7-1. Fault Action and Response

FAULT	CONDITION	GATE DRIVER	RECOVERY
V _{BSTx} undervoltage (BSTUV)	V _{BSTx} < V _{BSTUV}	GHx - Hi-Z	Automatic: V _{BSTx} > V _{BSTUV} and low to high PWM edge detected on INHx pin
GVDD undervoltage (GVDDUV)	V _{GVDD} < V _{GVDDUV}	Hi-Z	Automatic: V _{GVDD} > V _{GVDDUV}

7.3.3.1 V_{BSTx} Undervoltage Lockout (BSTUV)

The DRV8300U has separate voltage comparator to detect undervoltage condition for each phases. If at any time the voltage on the BSTx pin falls lower than the V_{BSTUV} threshold, high side external MOSFETs of that particular phase is disabled by disabling (Hi-Z) GHx pin. Normal operation starts again when the BSTUV condition clears and low to high PWM edge is detected on INHx input of the same phase that BSTUV condition is detected. BSTUV protection maintains that high-side MOSFETs are not driven when the BSTx pins has lower value.

7.3.3.2 GVDD Undervoltage Lockout (GVDDUV)

If at any time the voltage on the GVDD pin falls lower than the V_{GVDDUV} threshold voltage, all of the external MOSFETs are disabled. Normal operation starts again when the GVDDUV condition clears. GVDDUV protection maintains that external MOSFETs are not driven when the GVDD input is at lower value.

7.4 Device Functional Modes

The DRV8300U is in operating (active) mode, whenever the GVDD and BST pins are higher than the UV threshold (GVDD > V_{GVDDUV} and V_{BSTx} > V_{BSTUV}). In active mode, the gate driver output GHx and GLx follows respective inputs INHx and INLx.

8 Application and Implementation

Note

Information in the following applications sections is not part of the TI component specification, and TI does not warrant its accuracy or completeness. TI's customers are responsible for determining suitability of components for their purposes. Customers should validate and test their design implementation to confirm system functionality.

8.1 Application Information

The DRV8300U family of devices is primarily used in applications for three-phase brushless DC motor control. The design procedures in the [Section 8.2](#) section highlight how to use and configure the DRV8300U.

8.2 Typical Application

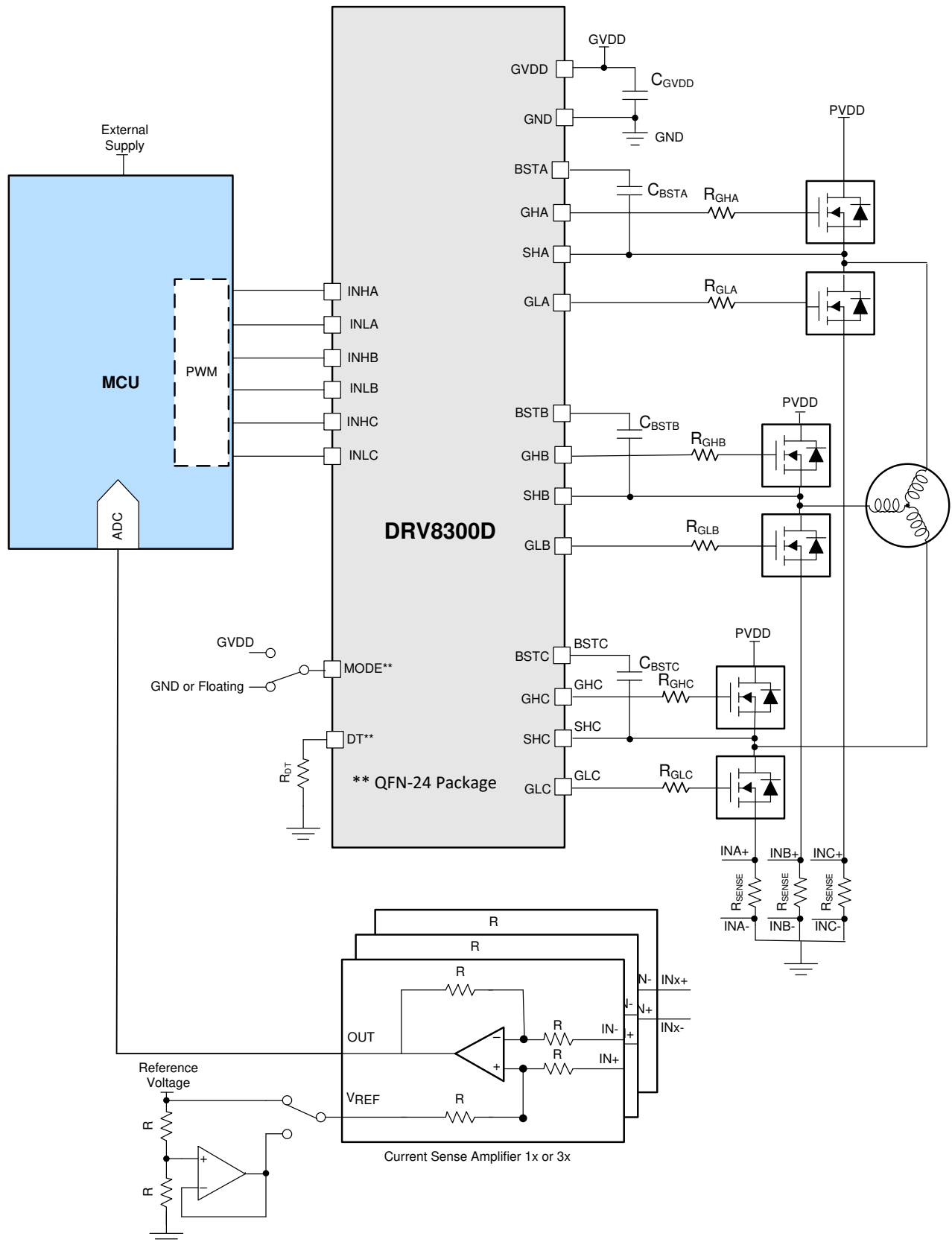

Figure 8-1. Application Schematic

8.2.1 Design Requirements

Table 8-1 lists the example design input parameters for system design.

Table 8-1. Design Parameters

EXAMPLE DESIGN PARAMETER	REFERENCE	EXAMPLE VALUE
MOSFET	-	CSD19532Q5B
Gate Supply Voltage	V_{GVDD}	12 V
Gate Charge	Q_G	48 nC

8.2.2 Bootstrap Capacitor and GVDD Capacitor Selection

The bootstrap capacitor must be sized to maintain the bootstrap voltage above the undervoltage lockout for normal operation. Equation 2 calculates the maximum allowable voltage drop across the bootstrap capacitor:

$$\Delta V_{BSTX} = V_{GVDD} - V_{BOOTD} - V_{BSTUV} \quad (2)$$

$$= 12V - 0.85V - 4.5V = 6.65V$$

where:

- V_{GVDD} is the supply voltage of the gate drive
- V_{BOOTD} is the forward voltage drop of the bootstrap diode
- V_{BSTUV} is the threshold of the bootstrap undervoltage lockout

In this example the allowed voltage drop across bootstrap capacitor is 6.65V. Minimizing ripple voltage as much as possible on both the bootstrap capacitor and GVDD capacitor is generally recommended. Many of commercial, industrial, and automotive applications use ripple value between 0.5V to 1V.

The total charge needed per switching cycle can be estimated with Equation 3:

$$Q_{TOT} = Q_G + \frac{I_{LBS_TRANS}}{f_{SW}} \quad (3)$$

$$= 48nC + 220\mu A / 20kHz = 50nC + 11nC = 59nC$$

where

- Q_G is the total MOSFET gate charge
- I_{LBS_TRAN} is the bootstrap pin leakage current
- f_{SW} is the PWM frequency

The minimum bootstrap capacitor can then be estimated as below assuming 1V ΔV_{BSTX} :

$$C_{BST_MIN} = Q_{TOT} / \Delta V_{BSTX} \quad (4)$$

$$= 59nC / 1V = 59nF$$

The calculated value of minimum bootstrap capacitor is 59nF. Note that, this value of capacitance is needed at full bias voltage. In practice, the value of the bootstrap capacitor must be greater than the calculated value to allow for situations where the power stage skip pulses due to various transient conditions. TI recommends to use a 100nF bootstrap capacitor in this example. TI recommends to include enough margin and place the bootstrap capacitor as close to the BSTx and SHx pins as possible.

$$C_{GVDD} \geq 10 \times C_{BSTX} \quad (5)$$

$$= 10 * 100nF = 1\mu F$$

For this example application choose $1\mu\text{F}$ C_{GVDD} capacitor. Choose a capacitor with a voltage rating at least twice the maximum voltage that the capacitor is exposed to because most ceramic capacitors lose significant capacitance when biased. This value also improves the long term reliability of the system.

8.2.3 Application Curves

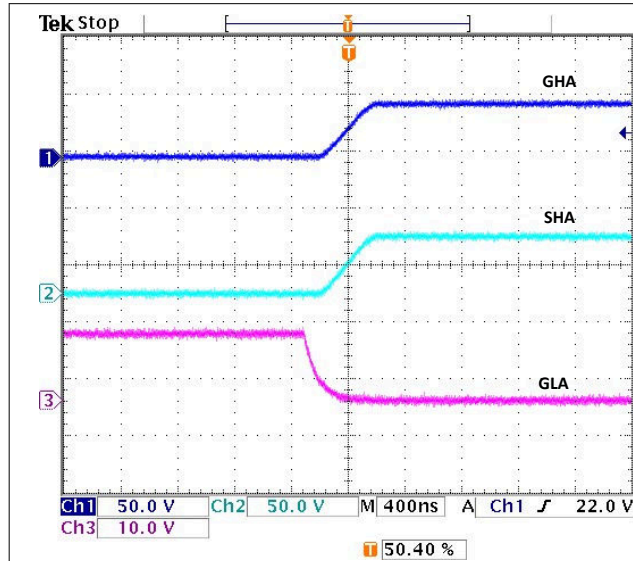

Figure 8-2. Gate voltages, SHx rising with 15 ohm gate resistor and CSD19532Q5B MOSFET

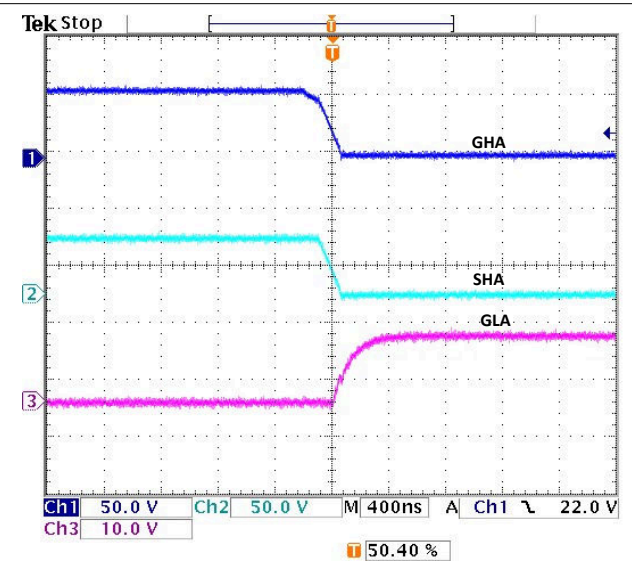

Figure 8-3. Gate voltages, SHx falling with 15 ohm gate resistor and CSD19532Q5B MOSFET

8.3 Power Supply Recommendations

The DRV8300U is designed to operate from an input voltage supply (GVDD) range from 4.8V to 20V. A local bypass capacitor is placed between the GVDD and GND pins. This capacitor is located as close to the device as possible. A low ESR, ceramic surface mount capacitor is recommended. TI recommends to use two capacitors across GVDD and GND: a low capacitance ceramic surface-mount capacitor for high frequency filtering placed very close to GVDD and GND pin, and another high capacitance value surface mount capacitor for device bias requirements. In a similar manner, the current pulses delivered by the GHx pins are sourced from the BSTx pins. Therefore, capacitor across the BSTx to SHx is recommended, this capacitor is high enough capacitance value capacitor to deliver GHx pulses

8.4 Layout

8.4.1 Layout Guidelines

- Low ESR/ESL capacitors must be connected close to the device between GVDD and GND and between BSTx and SHx pins to support high peak currents drawn from GVDD and BSTx pins during the turn-on of the external MOSFETs.
- To prevent large voltage transients at the drain of the top MOSFET, a low ESR electrolytic capacitor and a good quality ceramic capacitor must be connected between the high side MOSFET drain and ground.
- To avoid large negative transients on the switch node (SHx) pin, the parasitic inductances between the source of the high-side MOSFET and the source of the low-side MOSFET must be minimized.
- To avoid unexpected transients, the parasitic inductance of the GHx, SHx, and GLx connections must be minimized. Minimize the trace length and number of vias wherever possible. Minimum 10 mil and typical 15 mil trace width is recommended.
- Resistance between DT and GND must be place as close as possible to device
- Place the gate driver as close to the MOSFETs as possible. Confine the high peak currents that charge and discharge the MOSFET gates to a minimal physical area by reducing trace length. This confinement decreases the loop inductance and minimize noise issues on the gate terminals of the MOSFETs.

- In QFN package device variants, NC pins can be connected to GND to increase ground connection between thermal pad and external ground plane.
- Refer to sections *General Routing Techniques* and *MOSFET Placement and Power Stage Routing* in [Application Report](#)

8.4.2 Layout Example

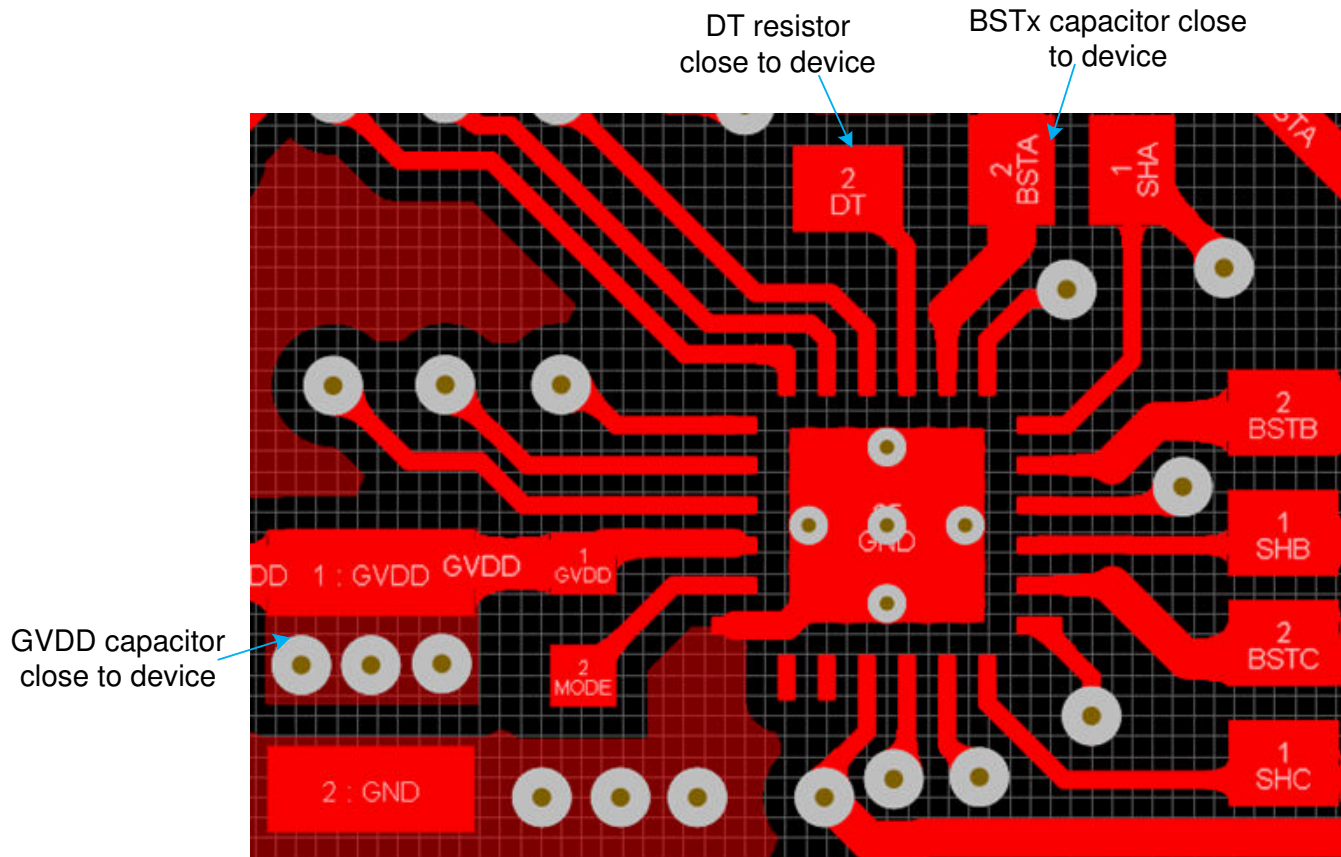

9 Device and Documentation Support

9.1 Receiving Notification of Documentation Updates

To receive notification of documentation updates, navigate to the device product folder on ti.com. Click on *Notifications* to register and receive a weekly digest of any product information that has changed. For change details, review the revision history included in any revised document.

9.2 Support Resources

[TI E2E™ support forums](#) are an engineer's go-to source for fast, verified answers and design help — straight from the experts. Search existing answers or ask your own question to get the quick design help you need.

Linked content is provided "AS IS" by the respective contributors. They do not constitute TI specifications and do not necessarily reflect TI's views; see TI's [Terms of Use](#).

9.3 Trademarks

TI E2E™ is a trademark of Texas Instruments.
All trademarks are the property of their respective owners.

9.4 Electrostatic Discharge Caution



This integrated circuit can be damaged by ESD. Texas Instruments recommends that all integrated circuits be handled with appropriate precautions. Failure to observe proper handling and installation procedures can cause damage.

ESD damage can range from subtle performance degradation to complete device failure. Precision integrated circuits may be more susceptible to damage because very small parametric changes could cause the device not to meet its published specifications.

9.5 Glossary

[TI Glossary](#) This glossary lists and explains terms, acronyms, and definitions.

10 Revision History

NOTE: Page numbers for previous revisions may differ from page numbers in the current version.

Changes from Revision A (October 2022) to Revision B (June 2025)	Page
• Removed "Preview" status from PW devices.....	1
• Updated GLx polarity with respect to INLx input for DRV8300UD and DRV8300UDI.....	3

Changes from Revision * (July 2022) to Revision A (October 2022)	Page
• Updated device status to Production Data.....	1

11 Mechanical, Packaging, and Orderable Information

The following pages include mechanical, packaging, and orderable information. This information is the most current data available for the designated devices. This data is subject to change without notice and revision of this document. For browser-based versions of this data sheet, refer to the left-hand navigation.

PACKAGING INFORMATION

Orderable part number	Status (1)	Material type (2)	Package Pins	Package qty Carrier	RoHS (3)	Lead finish/ Ball material (4)	MSL rating/ Peak reflow (5)	Op temp (°C)	Part marking (6)
DRV8300UDIPWR	Active	Production	TSSOP (PW) 20	3000 LARGE T&R	Yes	NIPDAU	Level-2-260C-1 YEAR	-40 to 125	8300UDI
DRV8300UDIPWR.A	Active	Production	TSSOP (PW) 20	3000 LARGE T&R	Yes	NIPDAU	Level-2-260C-1 YEAR	-40 to 125	8300UDI
DRV8300UDPWR	Active	Production	TSSOP (PW) 20	3000 LARGE T&R	Yes	NIPDAU	Level-2-260C-1 YEAR	-40 to 125	8300UD
DRV8300UDPWR.A	Active	Production	TSSOP (PW) 20	3000 LARGE T&R	Yes	NIPDAU	Level-2-260C-1 YEAR	-40 to 125	8300UD
DRV8300UDRGER	Active	Production	VQFN (RGE) 24	3000 LARGE T&R	Yes	SN	Level-1-260C-UNLIM	-40 to 125	8300UD
DRV8300UDRGER.A	Active	Production	VQFN (RGE) 24	3000 LARGE T&R	Yes	SN	Level-1-260C-UNLIM	-40 to 125	8300UD

(1) **Status:** For more details on status, see our [product life cycle](#).

(2) **Material type:** When designated, preproduction parts are prototypes/experimental devices, and are not yet approved or released for full production. Testing and final process, including without limitation quality assurance, reliability performance testing, and/or process qualification, may not yet be complete, and this item is subject to further changes or possible discontinuation. If available for ordering, purchases will be subject to an additional waiver at checkout, and are intended for early internal evaluation purposes only. These items are sold without warranties of any kind.

(3) **RoHS values:** Yes, No, RoHS Exempt. See the [TI RoHS Statement](#) for additional information and value definition.

(4) **Lead finish/Ball material:** Parts may have multiple material finish options. Finish options are separated by a vertical ruled line. Lead finish/Ball material values may wrap to two lines if the finish value exceeds the maximum column width.

(5) **MSL rating/Peak reflow:** The moisture sensitivity level ratings and peak solder (reflow) temperatures. In the event that a part has multiple moisture sensitivity ratings, only the lowest level per JEDEC standards is shown. Refer to the shipping label for the actual reflow temperature that will be used to mount the part to the printed circuit board.

(6) **Part marking:** There may be an additional marking, which relates to the logo, the lot trace code information, or the environmental category of the part.

Multiple part markings will be inside parentheses. Only one part marking contained in parentheses and separated by a "~" will appear on a part. If a line is indented then it is a continuation of the previous line and the two combined represent the entire part marking for that device.

Important Information and Disclaimer: The information provided on this page represents TI's knowledge and belief as of the date that it is provided. TI bases its knowledge and belief on information provided by third parties, and makes no representation or warranty as to the accuracy of such information. Efforts are underway to better integrate information from third parties. TI has taken and continues to take reasonable steps to provide representative and accurate information but may not have conducted destructive testing or chemical analysis on incoming materials and chemicals. TI and TI suppliers consider certain information to be proprietary, and thus CAS numbers and other limited information may not be available for release.

In no event shall TI's liability arising out of such information exceed the total purchase price of the TI part(s) at issue in this document sold by TI to Customer on an annual basis.

TAPE AND REEL INFORMATION

QUADRANT ASSIGNMENTS FOR PIN 1 ORIENTATION IN TAPE

*All dimensions are nominal

Device	Package Type	Package Drawing	Pins	SPQ	Reel Diameter (mm)	Reel Width W1 (mm)	A0 (mm)	B0 (mm)	K0 (mm)	P1 (mm)	W (mm)	Pin1 Quadrant
DRV8300UDIPWR	TSSOP	PW	20	3000	330.0	16.4	6.95	7.0	1.4	8.0	16.0	Q1
DRV8300UDPWR	TSSOP	PW	20	3000	330.0	16.4	6.95	7.0	1.4	8.0	16.0	Q1
DRV8300UDRGER	VQFN	RGE	24	3000	330.0	12.4	4.25	4.25	1.15	8.0	12.0	Q2

TAPE AND REEL BOX DIMENSIONS

*All dimensions are nominal

Device	Package Type	Package Drawing	Pins	SPQ	Length (mm)	Width (mm)	Height (mm)
DRV8300UDIPWR	TSSOP	PW	20	3000	353.0	353.0	32.0
DRV8300UDPWR	TSSOP	PW	20	3000	353.0	353.0	32.0
DRV8300UDRGER	VQFN	RGE	24	3000	367.0	367.0	35.0

PW0020A



PACKAGE OUTLINE

TSSOP - 1.2 mm max height

SMALL OUTLINE PACKAGE



4220206/A 02/2017

NOTES:

1. All linear dimensions are in millimeters. Any dimensions in parenthesis are for reference only. Dimensioning and tolerancing per ASME Y14.5M.
2. This drawing is subject to change without notice.
3. This dimension does not include mold flash, protrusions, or gate burrs. Mold flash, protrusions, or gate burrs shall not exceed 0.15 mm per side.
4. This dimension does not include interlead flash. Interlead flash shall not exceed 0.25 mm per side.
5. Reference JEDEC registration MO-153.

EXAMPLE BOARD LAYOUT

PW0020A

TSSOP - 1.2 mm max height

SMALL OUTLINE PACKAGE



LAND PATTERN EXAMPLE
EXPOSED METAL SHOWN
SCALE: 10X



SOLDER MASK DETAILS

4220206/A 02/2017

NOTES: (continued)

- 6. Publication IPC-7351 may have alternate designs.
- 7. Solder mask tolerances between and around signal pads can vary based on board fabrication site.

EXAMPLE STENCIL DESIGN

PW0020A

TSSOP - 1.2 mm max height

SMALL OUTLINE PACKAGE



SOLDER PASTE EXAMPLE
BASED ON 0.125 mm THICK STENCIL
SCALE: 10X

4220206/A 02/2017

NOTES: (continued)

8. Laser cutting apertures with trapezoidal walls and rounded corners may offer better paste release. IPC-7525 may have alternate design recommendations.
9. Board assembly site may have different recommendations for stencil design.

RGE 24

GENERIC PACKAGE VIEW

VQFN - 1 mm max height

PLASTIC QUAD FLATPACK - NO LEAD

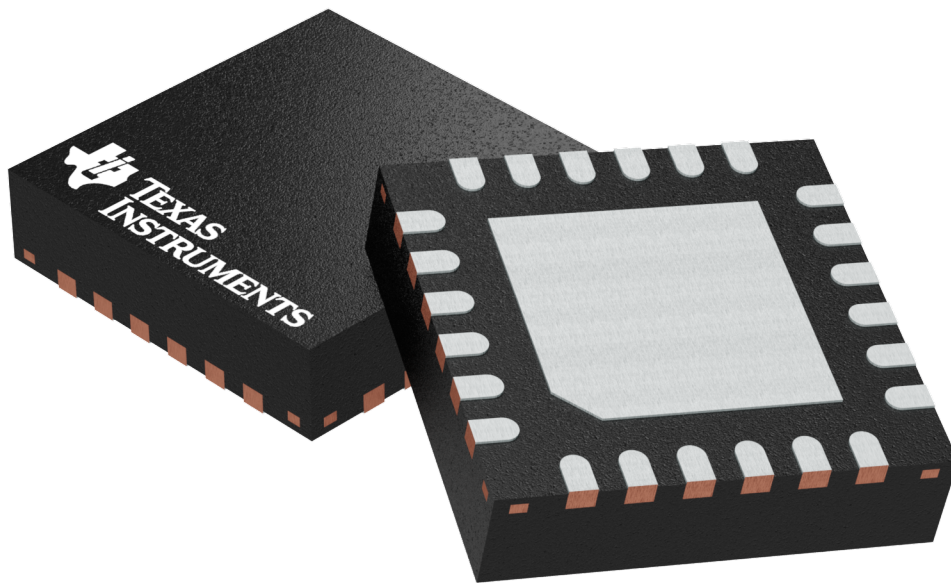

Images above are just a representation of the package family, actual package may vary.
Refer to the product data sheet for package details.

4204104/H

EXAMPLE STENCIL DESIGN

RGE0024B

VQFN - 1 mm max height

PLASTIC QUAD FLATPACK - NO LEAD

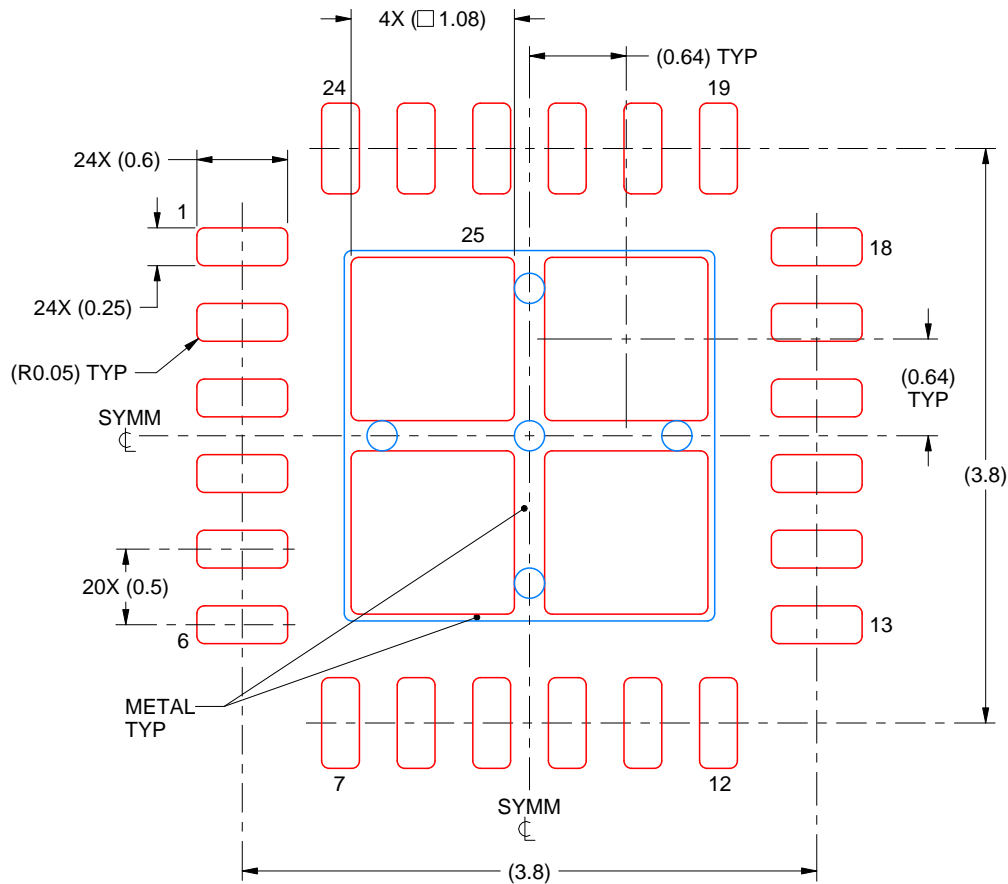

SOLDER PASTE EXAMPLE
BASED ON 0.125 mm THICK STENCIL

EXPOSED PAD 25
78% PRINTED SOLDER COVERAGE BY AREA UNDER PACKAGE
SCALE:20X

4219013/A 05/2017

NOTES: (continued)

6. Laser cutting apertures with trapezoidal walls and rounded corners may offer better paste release. IPC-7525 may have alternate design recommendations.

IMPORTANT NOTICE AND DISCLAIMER

TI PROVIDES TECHNICAL AND RELIABILITY DATA (INCLUDING DATASHEETS), DESIGN RESOURCES (INCLUDING REFERENCE DESIGNS), APPLICATION OR OTHER DESIGN ADVICE, WEB TOOLS, SAFETY INFORMATION, AND OTHER RESOURCES "AS IS" AND WITH ALL FAULTS, AND DISCLAIMS ALL WARRANTIES, EXPRESS AND IMPLIED, INCLUDING WITHOUT LIMITATION ANY IMPLIED WARRANTIES OF MERCHANTABILITY, FITNESS FOR A PARTICULAR PURPOSE OR NON-INFRINGEMENT OF THIRD PARTY INTELLECTUAL PROPERTY RIGHTS.

These resources are intended for skilled developers designing with TI products. You are solely responsible for (1) selecting the appropriate TI products for your application, (2) designing, validating and testing your application, and (3) ensuring your application meets applicable standards, and any other safety, security, regulatory or other requirements.

These resources are subject to change without notice. TI grants you permission to use these resources only for development of an application that uses the TI products described in the resource. Other reproduction and display of these resources is prohibited. No license is granted to any other TI intellectual property right or to any third party intellectual property right. TI disclaims responsibility for, and you fully indemnify TI and its representatives against any claims, damages, costs, losses, and liabilities arising out of your use of these resources.

TI's products are provided subject to [TI's Terms of Sale](#), [TI's General Quality Guidelines](#), or other applicable terms available either on ti.com or provided in conjunction with such TI products. TI's provision of these resources does not expand or otherwise alter TI's applicable warranties or warranty disclaimers for TI products. Unless TI explicitly designates a product as custom or customer-specified, TI products are standard, catalog, general purpose devices.

TI objects to and rejects any additional or different terms you may propose.

Copyright © 2026, Texas Instruments Incorporated

Last updated 10/2025