

TCA9847 Ultra Low-Voltage 8-Channel 1MHz Capable I²C Multiplexer

1 Features

- 1-to-8 bidirectional translating multiplexer with ultra low voltage translation down to 0.65V
- I²C Bus and SMBus compatible
- Active-low reset input
- Two address pins, allowing up to 16 devices on the I²C bus
- Channel selection through an I²C Bus, in any combination
- Power up with all switch channels deselected
- Low R_{ON} switches
- Allows voltage-level translation between 0.65V, 0.8, 1.2V, 1.8V, 2.5V, and 3.3V
- No glitch on power up
- Supports hot insertion
- Low standby current
- Operating power-supply voltage range of 1.65V to 3.6V
- 3.6V tolerant inputs
- 0 to 1MHz clock frequency
- Latch-up performance exceeds 100mA per JESD 78, class II
- ESD protection exceeds JESD 22
 - ±2000V human-body model (A114-A)
 - ±500V charged-device model (C101)

2 Applications

- Servers
- Routers (telecom switching equipment)
- [Factory automation](#)
- Products with I²C target address conflicts (such as multiple, identical temperature sensors)

3 Description

The TCA9847 device is an 8-channel, bidirectional translating multiplexer that can be controlled through the I²C bus. The SCL/SDA upstream pair fans out to eight downstream pairs, or channels. Any individual SCn/SDn channel or combination of channels can be selected, determined by the contents of the programmable control register. These downstream channels can be used to resolve I²C target address conflicts. For example, if eight identical digital temperature sensors are needed in the application, one sensor can be connected at each channel: 0-7.

The system controller can reset the TCA9847 in the event of a time-out, or other improper operation by asserting a low in the $\overline{\text{RESET}}$ input. Similarly, the power-on reset deselects all channels and initializes the I²C/SMBus state machine. Asserting $\overline{\text{RESET}}$ causes the same reset and initialization to occur without powering down the part. This allows recovery if one of the downstream I²C buses get stuck in a low state.

The pass gates of the switches are constructed so that VDD1/VDD2 pins can be used to limit the maximum high voltage, which is passed by the TCA9847. Limiting the maximum high voltage allows the use of different bus voltages on each pair, so that 0.65V, 0.8V, 1.2V, or 1.8V parts can communicate with 3.3V parts, without any additional protection. External pullup resistors pull the bus up to the desired voltage level for each channel. All I/O pins are 3.6V tolerant.

Package Information

PART NUMBER	PACKAGE (1)	PACKAGE SIZE(2)
TCA9847	PW (TSSOP, 24)	7.8mm × 6.4mm
	RGE (VQFN, 24)	4mm × 4mm

(1) For more information, see [Section 11](#).

(2) The package size (length × width) is a nominal value and includes pins, where applicable.

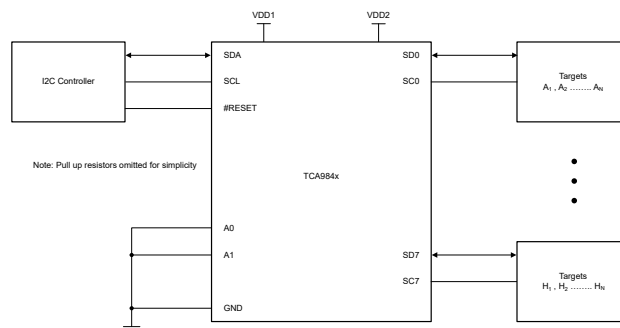

Simplified Application Diagram



Table of Contents

1 Features	1	7.5 Programming.....	14
2 Applications	1	8 Application and Implementation	21
3 Description	1	8.1 Application Information.....	21
4 Pin Configuration and Functions	3	8.2 Typical Application.....	21
5 Specifications	5	8.3 Power Supply Recommendations.....	23
5.1 Absolute Maximum Ratings.....	5	8.4 Layout.....	25
5.2 ESD Ratings.....	5	9 Device and Documentation Support	26
5.3 Recommended Operating Conditions.....	5	9.1 Documentation Support.....	26
5.4 Thermal Information.....	6	9.2 Receiving Notification of Documentation Updates....	26
5.5 Electrical Characteristics (Global).....	7	9.3 Support Resources.....	26
5.6 I ² C Interface Timing Requirements.....	7	9.4 Trademarks.....	26
5.7 Reset Timing Requirements.....	9	9.5 Electrostatic Discharge Caution.....	26
5.8 Switching Characteristics.....	9	9.6 Glossary.....	26
6 Parameter Measurement Information	10	10 Revision History	26
7 Detailed Description	12	11 Mechanical, Packaging, and Orderable Information	26
7.1 Overview.....	12	11.1 Tape and Reel Information.....	27
7.2 Functional Block Diagram.....	13	11.2 Mechanical Data.....	29
7.3 Feature Description.....	14		
7.4 Device Functional Modes.....	14		

4 Pin Configuration and Functions

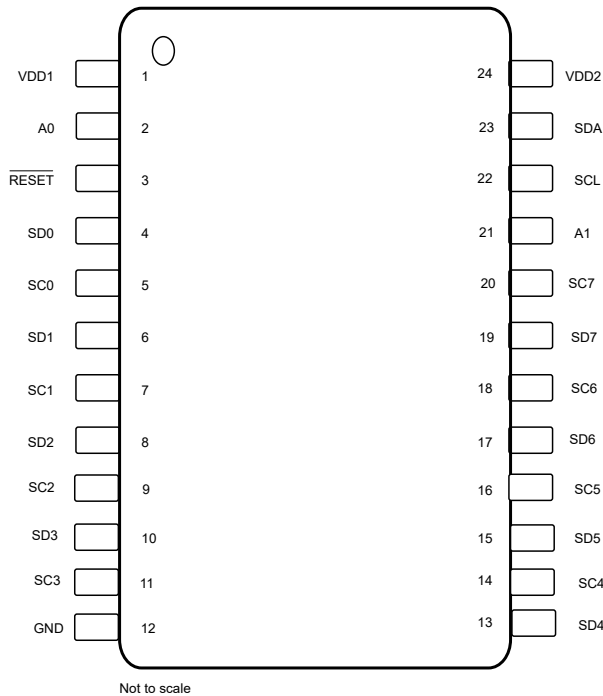

Figure 4-1. PW Package, 24-Pin TSSOP (Top View)

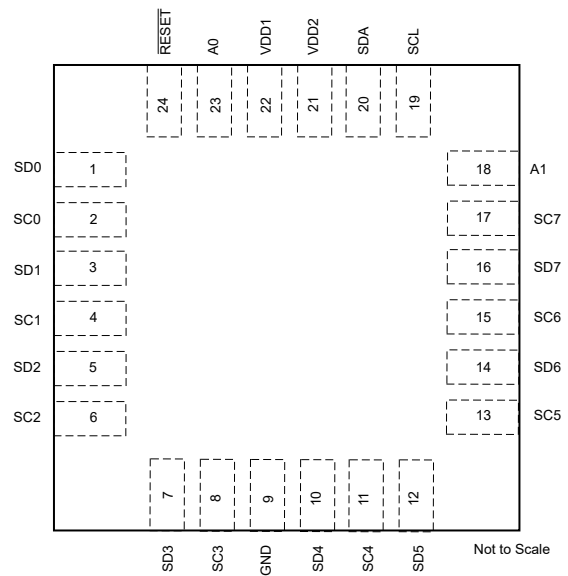

Figure 4-2. RGE Package, 24-Pin VQFN (Top View)

Table 4-1. Pin Functions

PIN			TYPE ⁽¹⁾	DESCRIPTION
NAME	TSSOP,(PW)	VQFN (RGE)		
A0	2	23	I	Address input 0. Connect directly to V _{DD2} or ground.
A1	21	18	I	Address input 1. Connect directly to V _{DD2} or ground.
VDD1	1	22	Power	Logic level power supply
VDD2	24	21	Power	Core logic power supply
RESET	3	24	I	Active-low reset input. Connect to V _{DD2} or V _{DPUM} ⁽²⁾ through a pullup resistor, if not used.
SD0	4	1	I/O	Serial data 0. Connect to V _{DPU0} ⁽²⁾ through a pullup resistor.
SC0	5	2	I/O	Serial clock 0. Connect to V _{DPU0} ⁽²⁾ through a pullup resistor.
SD1	6	3	I/O	Serial data 1. Connect to V _{DPU1} ⁽²⁾ through a pullup resistor.
SC1	7	4	I/O	Serial clock 1. Connect to V _{DPU1} ⁽²⁾ through a pullup resistor.
SD2	8	5	I/O	Serial data 2. Connect to V _{DPU2} ⁽²⁾ through a pullup resistor.
SC2	9	6	I/O	Serial clock 2. Connect to V _{DPU2} ⁽²⁾ through a pullup resistor.
SD3	10	7	I/O	Serial data 3. Connect to V _{DPU3} ⁽²⁾ through a pullup resistor.
SC3	11	8	I/O	Serial clock 3. Connect to V _{DPU3} ⁽²⁾ through a pullup resistor.
SD4	13	10	I/O	Serial data 4. Connect to V _{DPU4} ⁽²⁾ through a pullup resistor.
SC4	14	11	I/O	Serial clock 4. Connect to V _{DPU4} ⁽²⁾ through a pullup resistor.
SD5	15	12	I/O	Serial data 5. Connect to V _{DPU5} ⁽²⁾ through a pullup resistor.
SC5	16	13	I/O	Serial clock 5. Connect to V _{DPU5} ⁽²⁾ through a pullup resistor.
SD6	17	14	I/O	Serial data 6. Connect to V _{DPU6} ⁽²⁾ through a pullup resistor.
SC6	18	15	I/O	Serial clock 6. Connect to V _{DPU6} ⁽²⁾ through a pullup resistor.
SD7	19	16	I/O	Serial data 7. Connect to V _{DPU7} ⁽²⁾ through a pullup resistor.
SC7	20	17	I/O	Serial clock 7. Connect to V _{DPU7} ⁽²⁾ through a pullup resistor.
SCL	22	19	I/O	Serial clock bus. Connect to V _{DPUM} ⁽²⁾ through a pullup resistor.
SDA	23	20	I/O	Serial data bus. Connect to V _{DPUM} ⁽²⁾ through a pullup resistor.

Table 4-1. Pin Functions (continued)

PIN			TYPE ⁽¹⁾	DESCRIPTION
NAME	TSSOP(PW)	VQFN (RGE)		
GND	12	9	—	Supply ground

(1) I = input, O = output

(2) V_{DPUX} is the pullup reference voltage for the associated data line. V_{DPU0} is the controller I²C reference voltage and V_{DPU0} - V_{DPU7} are the target channel reference voltages.

5 Specifications

5.1 Absolute Maximum Ratings

over operating free-air temperature range (unless otherwise noted) ⁽¹⁾

		MIN	MAX	UNIT
V _{CC}	Supply voltage	-0.5	4	V
V _I	Input voltage ⁽²⁾	-0.5	4	V
I _I	Input current	-20	20	mA
I _O	Output current	-25	25	mA
I _{CC}	Supply current	-100	100	mA
T _{amb}	Ambient Temperature	-40	125	°C
T _{stg}	Storage temperature	-65	150	°C

- (1) Operation outside the Absolute Maximum Ratings may cause permanent device damage. Absolute Maximum Ratings do not imply functional operation of the device at these or any other conditions beyond those listed under Recommended Operating Conditions. If used outside the Recommended Operating Conditions but within the Absolute Maximum Ratings, the device may not be fully functional, and this may affect device reliability, functionality, performance, and shorten the device lifetime.
- (2) The input negative-voltage and output voltage ratings can be exceeded if the input and output current ratings are observed.

5.2 ESD Ratings

			VALUE	UNIT
V _(ESD)	Electrostatic discharge	Human body model (HBM), per ANSI/ESDA/JEDEC JS-001 ⁽¹⁾	±2000	V
		Charged-device model (CDM), per ANSI/ESDA/JEDEC JS-002 ⁽²⁾	±500	

- (1) JEDEC document JEP155 states that 500V HBM allows safe manufacturing with a standard ESD control process.
- (2) JEDEC document JEP157 states that 250V CDM allows safe manufacturing with a standard ESD control process.

5.3 Recommended Operating Conditions

T_{amb} = -40°C to 125°C; unless otherwise specified

			MIN	TYP	MAX	UNIT
VDD1	Supply voltage 1		0.65		3.6	V
VDD2	Supply voltage 2		1.65		3.6	V
IDD (VDD2)	Supply Current on VDD2	VDD1 = 3.6; VDD2 = 3.6; SC0-7 and SD0-7 is not connected; RESET = VDD1; A0=A1=SCL; continuous register read/write				
IDD (VDD2)	Supply Current on VDD2	SCL = 0 kHz		5	12	µA
IDD (VDD2)	Supply Current on VDD2	SCL = 100 kHz		8	20	µA
IDD (VDD2)	Supply Current on VDD2	SCL = 1000 kHz		65	150	µA
IDD (VDD1)	Supply Current on VDD1	VDD1 = 3.6; VDD2 = 3.6; SC0-7 and SD0-7 is not connected; RESET = VDD1; A0=A1=SCL; continuous register read/write				
		SCL = 0kHz	-5	-2	+2	µA
		SCL = 100kHz		5	15	µA
		SCL = 1000kHz		45	100	µA
VPOR	Power-On Reset Voltage			1.2	1.5	V
T _A	Operating free-air temperature		-40		125	°C

5.4 Thermal Information

THERMAL METRIC ⁽¹⁾		TCA984x		UNIT
		PW(TSSOP)	RGE(VQFN)	
		24 PINS	24 PINS	
$R_{\theta JA}$	Junction-to-ambient thermal resistance	TBD	TBD	°C/W
$R_{\theta JC(top)}$	Junction-to-case (top) thermal resistance	TBD	TBD	°C/W
$R_{\theta JB}$	Junction-to-board thermal resistance	TBD	TBD	°C/W
Ψ_{JT}	Junction-to-top characterization parameter	TBD	TBD	°C/W
Ψ_{JB}	Junction-to-board characterization parameter	TBD	TBD	°C/W
$R_{\theta JC(bot)}$	Junction-to-case (bottom) thermal resistance	TBD	TBD	°C/W

- (1) For more information about traditional and new thermal metrics, see the [Semiconductor and IC Package Thermal Metrics](#) application report.

5.5 Electrical Characteristics (Global)

T_A = 25°C (unless otherwise noted)

PARAMETER		TEST CONDITIONS	T _A	MIN	TYP	MAX	UNIT
Recommended Supply Sequencing and Ramp Rates							
(dV/dt) _f	fall rate of change of voltage		–40°C to +125°C	0.1		2000	ms
(dV/dt) _r	rise rate of change of voltage		–40°C to +125°C	0.1		2000	ms
t _{d(rst)}	reset delay time		–40°C to +125°C	10			us
ΔV _{DD(gl)}	glitch supply voltage difference		–40°C to +125°C			1	V
t _{w(gl)VDD}	supply voltage glitch pulse width		–40°C to +125°C			10	us
V _{POR(trip)}	power-on reset trip voltage	Falling VDD2	–40°C to +125°C	0.7			V
		Rising VDD2	–40°C to +125°C			1.5	V
SCL/SDA							
V _{IH}	Logic voltage high		–40°C to +125°C	0.7V _{DD1}		3.6	V
V _{IL}	Logic voltage low		–40°C to +125°C	–0.5	+0.3V _{D1}		V
I _{OL}	LOW-level output current	V _{OL} = 0.4V	–40°C to +125°C	20			mA
I _{IL}	Input leakage current	V _I = VDD or 0	–40°C to +125°C	–1		1	uA
C _{IN}	Logic input capacitance	V _I = VSS; all channels disabled	–40°C to +125°C		10	12	pF
SEL Inputs: A0-A1, RESET							
V _{IH}	Logic voltage high		–40°C to +125°C	0.7V _{DD1}		3.6	V
V _{IL}	Logic voltage low		–40°C to +125°C	–0.5	+0.3V _{D1}		V
I _{IL}	Input leakage current	V _I = VDD or 0	–40°C to +125°C	–1		1	μA
C _{IN}	Logic input capacitance	V _I = VSS; all channels disabled	–40°C to +125°C		2	4	pF
Pass Gate							
R _{ON}	ON-state resistance	VDD1 = 0.8V; VDD2 ≥ 1.65V; Vi(sw) = 0.16V; IO = 3mA	–40°C to +125°C		10	24	Ω
		VDD1 = 0.65V; VDD2 ≥ 1.65V; Vi(sw) = 0.16V; IO = 3mA	–40°C to +125°C		10	24	Ω
		VDD1 = 1.2V; VDD2 ≥ 1.8V; Vi(sw) = 0.24V; IO = 6mA	–40°C to +125°C		7	18	Ω
		VDD1 > 2V; VDD2 ≥ 2.5V; Vi(sw) = 0.4V; IO = 20mA	–40°C to +125°C		5	12	Ω
I _{o(sw)}	Switch Output Current	VDD2 = 1.65V to 3.6V; Vi(sw) = VDD1 to 3.6V; Vo(sw) = VDD1 to 3.6V	–40°C to +125°C	0		100	μA
IL	Leakage current	V _I = VDD or GND	–40°C to +125°C	–1		+1.5	μA
COFF	Input/Output Capacitance	V _I = GND; all switches disabled	–40°C to +125°C		3	5	pF

5.6 I²C Interface Timing Requirements

over recommended operating free-air temperature range (unless otherwise noted) (see [Figure 6-1](#))

		MIN	MAX	UNIT
STANDARD MODE				
f _{scl}	I ² C clock frequency	0	100	kHz
t _{sch}	I ² C clock high time	4		μs
t _{scl}	I ² C clock low time	4.7		μs
t _{sp}	I ² C spike time	50		ns
t _{sds}	I ² C serial-data setup time	250		ns
t _{sdh}	I ² C serial-data hold time	0 ⁽¹⁾		μs
t _{icr}	I ² C input rise time		1000	ns

5.6 I²C Interface Timing Requirements (continued)

 over recommended operating free-air temperature range (unless otherwise noted) (see [Figure 6-1](#))

		MIN	MAX	UNIT	
t _{icf}	I ² C input fall time		300	ns	
t _{ocf}	I ² C output (SDn) fall time (10pF to 400pF bus)		300	ns	
t _{buf}	I ² C bus free time between stop and start	4.7		μs	
t _{sts}	I ² C start or repeated start condition setup	4.7		μs	
t _{sth}	I ² C start or repeated start condition hold	4		μs	
t _{sps}	I ² C stop condition setup	4		μs	
t _{vdL(Data)}	Valid-data time (high to low) ⁽²⁾	SCL low to SDA output low valid	1	μs	
t _{vdH(Data)}	Valid-data time (low to high) ⁽²⁾	SCL low to SDA output high valid	0.6	μs	
t _{vd(ack)}	Valid-data time of ACK condition	ACK signal from SCL low to SDA output low	1	μs	
C _b	I ² C bus capacitive load		400	pF	
FAST MODE					
f _{scl}	I ² C clock frequency	0	400	kHz	
t _{sch}	I ² C clock high time	0.6		μs	
t _{scl}	I ² C clock low time	1.3		μs	
t _{sp}	I ² C spike time	50		ns	
t _{sds}	I ² C serial-data setup time	100		ns	
t _{sdh}	I ² C serial-data hold time	0 ⁽¹⁾		μs	
t _{icr}	I ² C input rise time	20 + 0.1C _b ⁽³⁾	300	ns	
t _{icf}	I ² C input fall time	20 + 0.1C _b ⁽³⁾	300	ns	
t _{ocf}	I ² C output (SDn) fall time (10pF to 400pF bus)	20 + 0.1C _b ⁽³⁾	300	ns	
t _{buf}	I ² C bus free time between stop and start	1.3		μs	
t _{sts}	I ² C start or repeated start condition setup	0.6		μs	
t _{sth}	I ² C start or repeated start condition hold	0.6		μs	
t _{sps}	I ² C stop condition setup	0.6		μs	
t _{vdL(Data)}	Valid-data time (high to low) ⁽²⁾	SCL low to SDA output low valid	1	μs	
t _{vdH(Data)}	Valid-data time (low to high) ⁽²⁾	SCL low to SDA output high valid	0.6	μs	
t _{vd(ack)}	Valid-data time of ACK condition	ACK signal from SCL low to SDA output low	1	μs	
C _b	I ² C bus capacitive load		400	pF	
FAST MODE PLUS					
f _{scl}	I ² C clock frequency	I ² C clock frequency	0	1000	kHz
t _{sch}	I ² C clock high time	I ² C clock high time	0.26		μs
t _{scl}	I ² C clock low time	I ² C clock low time	0.5		μs
t _{sp}	I ² C spike time	I ² C spike time		50	ns
t _{sds}	I ² C serial-data setup time	I ² C serial-data setup time	100		ns
t _{sdh}	I ² C serial-data hold time	I ² C serial-data hold time	0 ⁽¹⁾		μs
t _{icr}	I ² C input rise time	I ² C input rise time		120	ns
t _{icf}	I ² C input fall time	I ² C input fall time	20 x (VDD / 5.5V) ⁽³⁾	120	ns
t _{buf}	I ² C bus free time between stop and start	I ² C bus free time between stop and start	0.5		μs
t _{sts}	I ² C start or repeated start condition setup	I ² C start or repeated start condition setup	0.26		μs
t _{sth}	I ² C start or repeated start condition hold	I ² C start or repeated start condition hold	0.26		μs
t _{sps}	I ² C stop condition setup	I ² C stop condition setup	0.6		μs
t _{vdL(Data)}	Valid-data time (high to low) ⁽²⁾	SCL low to SDA output low valid	0.45		μs
t _{vdH(Data)}	Valid-data time (low to high) ⁽²⁾	SCL low to SDA output high valid	0.45		μs
t _{vd(ack)}	Valid-data time of ACK condition	ACK signal from SCL low to SDA output low	0.45		μs

5.6 I²C Interface Timing Requirements (continued)

over recommended operating free-air temperature range (unless otherwise noted) (see [Figure 6-1](#))

PARAMETER			MIN	MAX	UNIT
C _b	I ² C bus capacitive load	I ² C bus capacitive load		550	pF

- (1) A device internally must provide a hold time of at least 300ns for the SDA signal (referred to the V_{IH} min of the SCL signal), to bridge the undefined region of the falling edge of SCL.
- (2) Data taken using a 1kΩ pullup resistor and 50pF load
- (3) C_b = total bus capacitance of one bus line in pF

5.7 Reset Timing Requirements

over recommended operating free-air temperature range (unless otherwise noted)

PARAMETER			MIN	MAX	UNIT
t _{wrs(L)}	Low-level reset time		100		ns
t _{REC(STA)}	Recovery time from $\overline{\text{RESET}}$ to start		0		ns

5.8 Switching Characteristics

over recommended operating free-air temperature range, C_L ≤ 100pF (unless otherwise noted) (see [Figure 6-1](#))

PARAMETER			FROM (INPUT)	TO (OUTPUT)	MIN	MAX	UNIT
t _{pd} ⁽¹⁾	Propagation delay time	R _{ON} = 20 Ω, C _L = 50pF	SDA or SCL	SDn or SCn		1	ns
t _{rst} ⁽²⁾	$\overline{\text{RESET}}$ time (SDA clear)		$\overline{\text{RESET}}$	SDA	500		ns

- (1) The propagation delay is the calculated RC time constant of the typical ON-state resistance of the switch and the specified load capacitance, when driven by an ideal voltage source (zero output impedance).
- (2) t_{rst} is the propagation delay measured from the time the $\overline{\text{RESET}}$ pin is first asserted low to the time the SDA pin is asserted high, signaling a stop condition. t_{rst} must be a minimum of t_{WL}.

6 Parameter Measurement Information

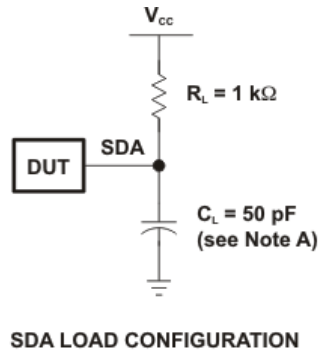

ADVANCE INFORMATION

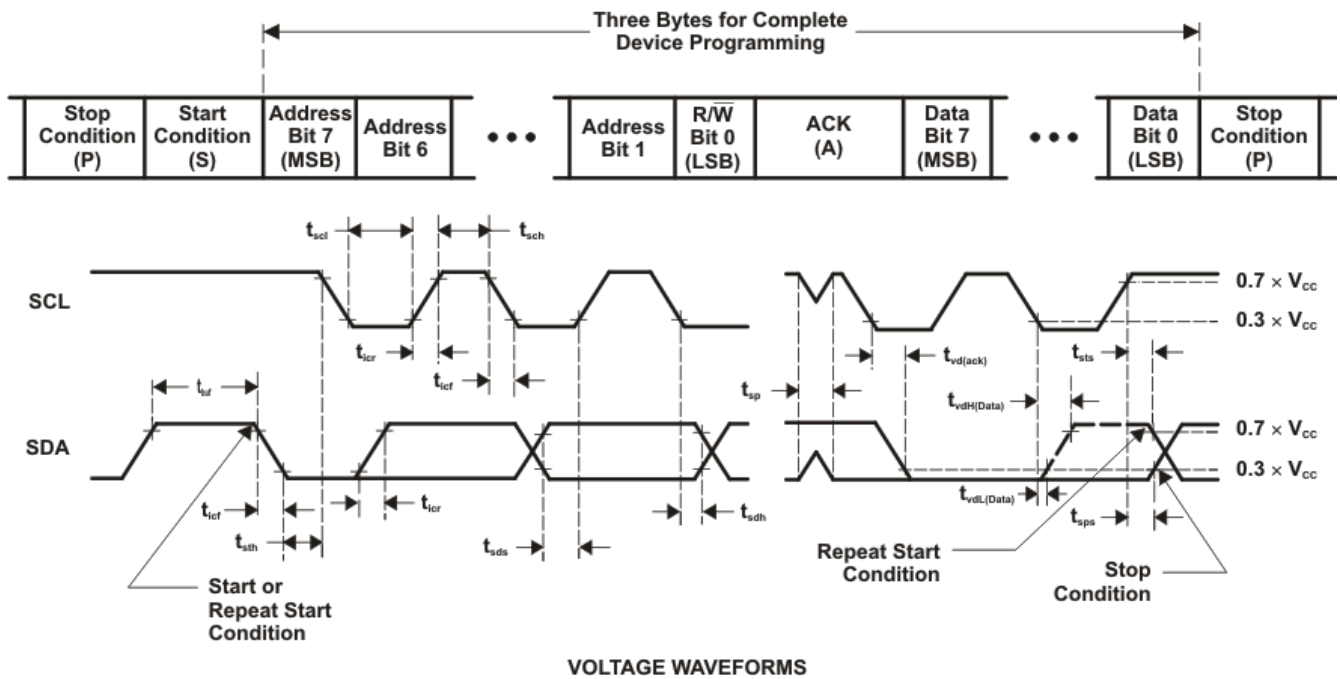

BYTE	DESCRIPTION
1	I ² C address
2, 3	P-port data

- A. C_L includes probe and jig capacitance.
- B. All inputs are supplied by generators having the following characteristics: $PRR \leq 10\text{MHz}$, $Z_O = 50\Omega$, $t_r/t_f \leq 30\text{ns}$.
- C. Not all parameters and waveforms are applicable to all devices.

Figure 6-1. I²C Load Circuit and Voltage Waveforms

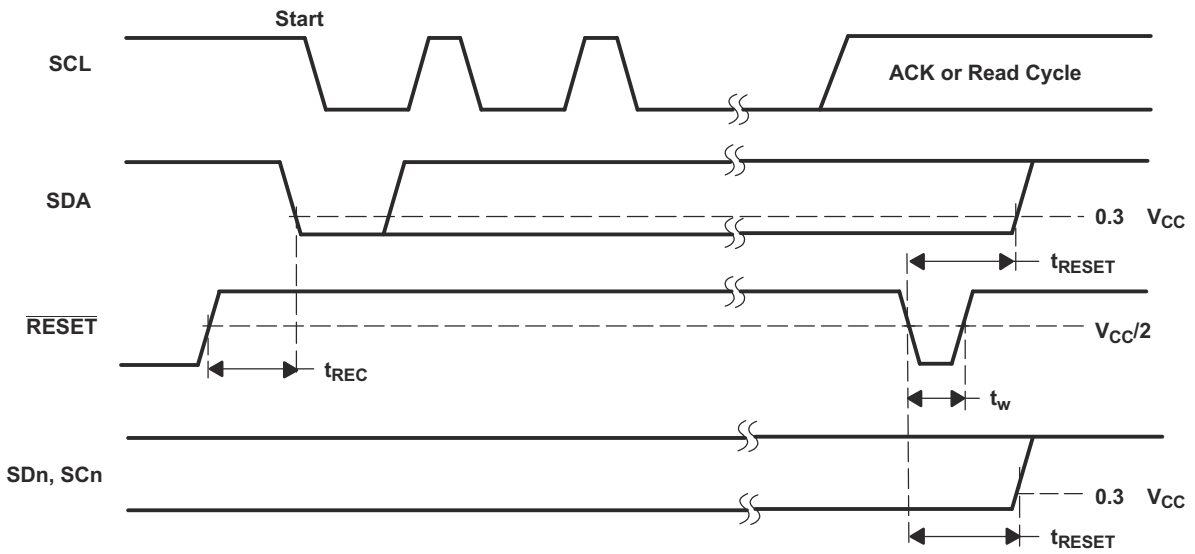
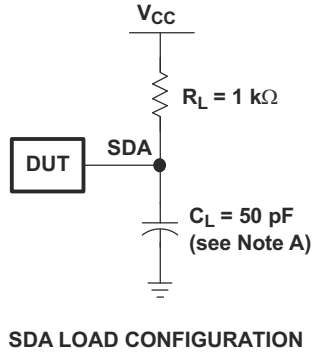

- A. C_L includes probe and jig capacitance.
- B. All inputs are supplied by generators having the following characteristics: $PRR \leq 10\text{MHz}$, $Z_O = 50\Omega$, $t_r/t_f \leq 30\text{ns}$.
- C. I/Os are configured as inputs.
- D. Not all parameters and waveforms are applicable to all devices.

Figure 6-2. Reset Load Circuit and Voltage Waveforms

7 Detailed Description

7.1 Overview

The TCA9847 is an 8-channel, bidirectional translating I²C multiplexer. The controller SCL/SDA signal pair is directed to eight channels of target devices, SC0/SD0-SC7/SD7. Any individual downstream channel can be selected as well as any combination of the eight channels.

The device offers an active-low $\overline{\text{RESET}}$ input which resets the state machine and allows the TCA9847 to recover if one of the downstream I²C buses get stuck in a low state. The state machine of the device can also be reset by cycling the power supply, V_{CC}, also known as a power-on reset (POR). Both the $\overline{\text{RESET}}$ function and a POR cause all channels to be deselected.

The connections of the I²C data path are controlled by the same I²C controller device that is switched to communicate with multiple I²C targets. After the successful acknowledgment of the target address (hardware selectable by A0 and A1 pins), a single 8-bit control register is written to or read from to determine the selected channels.

The TCA9847 can also be used for voltage translation, allowing the use of different bus voltages on each SCn/SDn pair such that 0.65V, 0.8V, 1.2V, or 1.8V parts can communicate with 3.3V parts. This action is achieved by using external pullup resistors to pull the bus up to the desired voltage for the controller and each target channel.

7.2 Functional Block Diagram

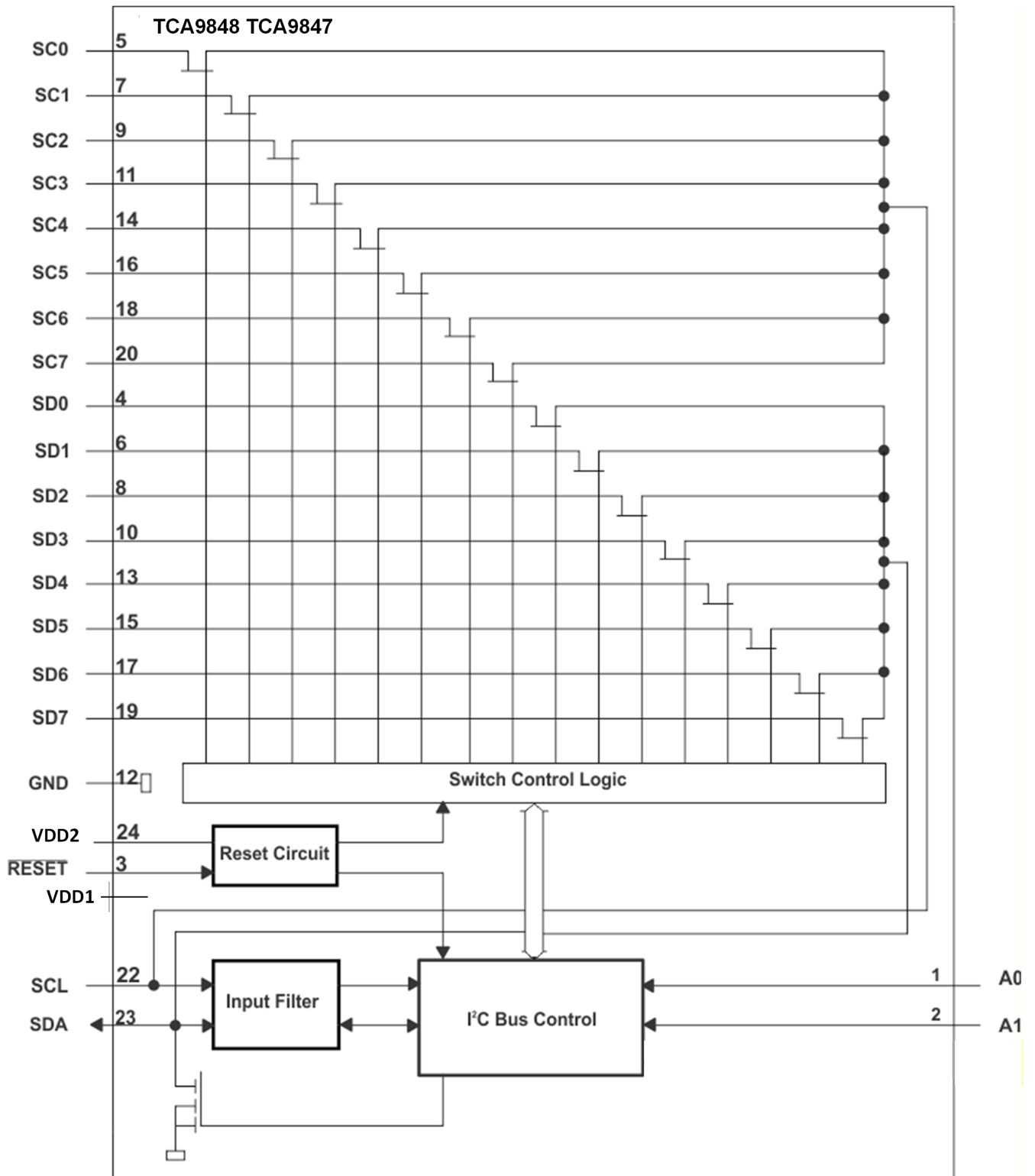

ADVANCE INFORMATION

7.3 Feature Description

The TCA9847 is an 8-channel, bidirectional translating multiplexer for I²C buses that supports standard-mode (100kHz), fast-mode (400kHz), and fast-mode-plus (1MHz) operation. The TCA9847 features I²C control using a single 8-bit control register in which each bit controls the enabling and disabling of one of the corresponding 8 multiplexer channels for I²C data flow. Depending on the application, voltage translation of the I²C bus can also be achieved using the TCA9847 to allow 0.65V, 0.8V, 1.2V, or 1.8V parts to communicate with 3.3V parts. Additionally, in the event that communication on the I²C bus enters a fault state, the TCA9847 can be reset to resume normal operation using the $\overline{\text{RESET}}$ pin feature or by a power-on reset which results from cycling power to the device.

7.4 Device Functional Modes

7.4.1 $\overline{\text{RESET}}$ Input

The $\overline{\text{RESET}}$ input is an active-low signal that can be used to recover from a bus-fault condition. When this signal is asserted low for a minimum of t_{WL} , the TCA9847 resets the registers and I²C state machine and deselects all channels. The $\overline{\text{RESET}}$ input must be connected to V_{CC} through a pullup resistor.

7.4.2 Power-On Reset

When power is applied to the VCC pin, an internal power-on reset holds the TCA9847 in a reset condition until V_{CC} has reached V_{PORR}. At this point, the reset condition is released, and the TCA9847 registers and I²C state machine are initialized to the default states, all zeroes, causing all the channels to be deselected. Thereafter, V_{CC} must be lowered below V_{PORF} to reset the device.

7.5 Programming

7.5.1 I²C Interface

The TCA9847 has a standard bidirectional I²C interface that is controlled by a controller device to be configured or read the status of this device. Each target on the I²C bus has a specific device address to differentiate between other target devices that are on the same I²C bus. Many target devices require configuration upon startup to set the behavior of the device. This is typically done when the controller accesses internal register maps of the target, which have unique register addresses. A device can have one or multiple registers where data is stored, written, or read.

The physical I²C interface consists of the serial clock (SCL) and serial data (SDA) lines. Both SDA and SCL lines must be connected to V_{CC} through a pullup resistor. The size of the pullup resistor is determined by the amount of capacitance on the I²C lines. (See also [I2C Bus Pullup Resistor Calculation application note](#). Data transfer can be initiated only when the bus is idle. A bus is considered idle if both SDA and SCL lines are high after a STOP condition (See [Figure 7-1](#) and [Figure 7-2](#)).

The following is the general procedure for a controller to access a target device:

1. If a controller wants to send data to a target:
 - Controller-transmitter sends a START condition and addresses the target-receiver.
 - Controller-transmitter sends data to target-receiver.
 - Controller-transmitter terminates the transfer with a STOP condition.
2. If a controller wants to receive or read data from a target:
 - Controller-receiver sends a START condition and addresses the target-transmitter.
 - Controller-receiver sends the requested register to read to target-transmitter.
 - Controller-receiver receives data from the target-transmitter.

- Controller-receiver terminates the transfer with a STOP condition.

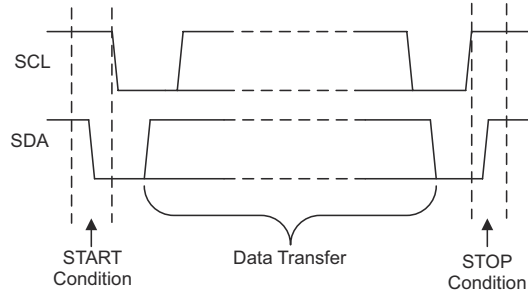

Figure 7-1. Definition of Start and Stop Conditions

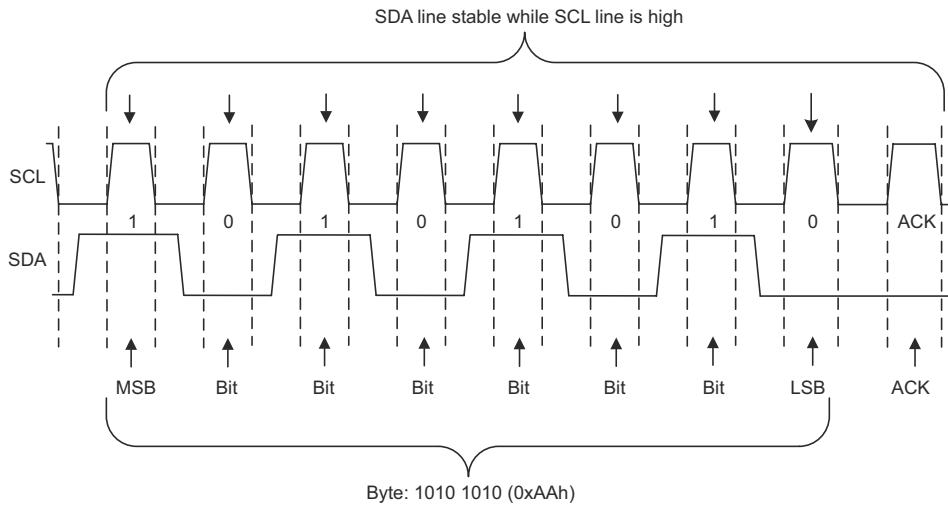

Figure 7-2. Bit Transfer

7.5.2 Device Address

The last bit of the target address defines the operation (read or write) to be performed. When high (1), a read is selected, while a low (0) selects a write operation.

Table 7-1 shows the TCA9847 address reference.

Table 7-1. Address Reference

INPUTS		I ² C BUS TARGETADDRESS
A1	A0	
L	SCL	0xE0h (hexadecimal)
L	L	0xE2h (hexadecimal)
L	SDA	0xE4h (hexadecimal)
L:	H	0xE6h (hexadecimal)
H	SCL	0xE8h (hexadecimal)
H	L	0xEAh (hexadecimal)
H	SDA	0xECh (hexadecimal)
H	H	0xEEh (hexadecimal)
SCL	SCL	0xB0h (hexadecimal)
SCL	L	0xB2h (hexadecimal)
SCL	SDA	0xB4h (hexadecimal)
SCL	H	0xB6h (hexadecimal)
SDA	SCL	0xB8h (hexadecimal)
SDA	L	0xBAh (hexadecimal)
SDA	SDA	0xBCh (hexadecimal)
SDA	1	0xBEh (hexadecimal)

7.5.3 Bus Transactions

Data must be sent to and received from the target devices, and this is accomplished by reading from or writing to registers in the target device.

Registers are locations in the memory of the target which contain information, whether configuration information or some sampled data to send back to the controller. The controller must write information to these registers to instruct the target device to perform a task.

While having registers in I²C targets is common, note that not all target devices have registers. Some devices are simple and contain only 1 register, which can be written to directly by sending the register data immediately after the target address, instead of addressing a register. The TCA9847 is an example of a single-register device, which is controlled through I²C commands. Because the device has 1 bit to enable or disable a channel, there is only 1 register needed, and the controller merely writes the register data after the target address, skipping the register number.

7.5.3.1 Writes

To write on the I²C bus, the controller sends a START condition on the bus with the address of the target, as well as the last bit (the R/ \bar{W} bit) set to 0, which signifies a write. The target acknowledges, letting the controller know the target is ready. After this action, the controller starts sending the control register data to the target until the controller has sent all the data necessary (which is sometimes only a single byte), and the controller terminates the transmission with a STOP condition.

There is no limit to the number of bytes sent, but the last byte sent is what is in the register.

Figure 7-3 shows an example of writing a single byte to a target register.

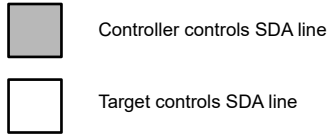

Write to one register in a device

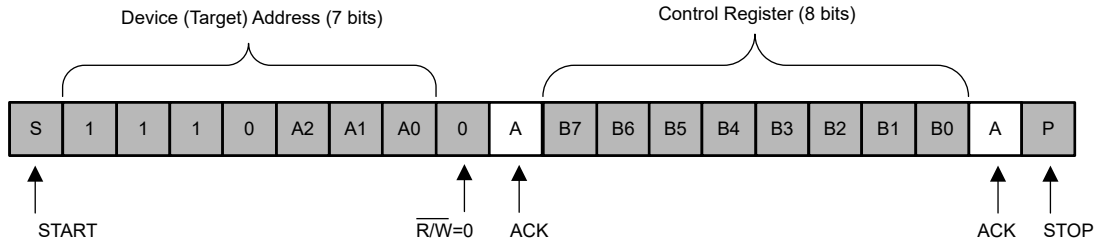

Figure 7-3. Write to Register

7.5.3.2 Reads

Reading from a target is very similar to writing, but the controller sends a START condition, followed by the target address with the R/ \bar{W} bit set to 1 (signifying a read). The target acknowledges the read request, and the controller releases the SDA bus but continues supplying the clock to the target. During this part of the transaction, the controller becomes the controller-receiver, and the target becomes the target-transmitter.

The controller continues to send out the clock pulses, but releases the SDA line so that the target can transmit data. At the end of every byte of data, the controller sends an ACK to the target, letting the target know that the controller is ready for more data. After the controller has received the number of bytes the controller is expecting, the controller sends a NACK, signaling to the target to halt communications and release the bus. The controller follows this action up with a STOP condition.

Figure 7-4 shows an example of reading a single byte from a target register.

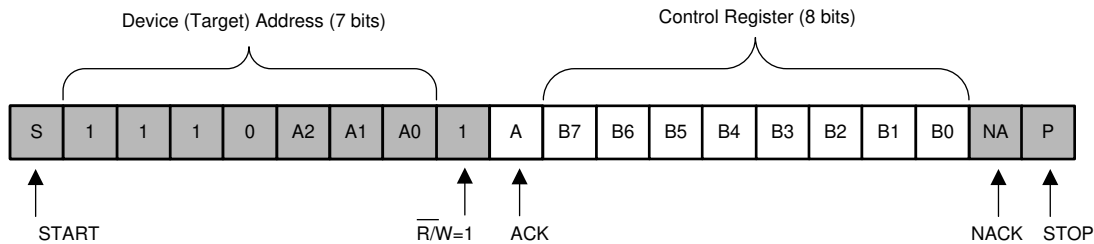
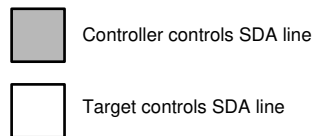

Figure 7-4. Read from Control Register

7.5.4 Control Register

Following the successful acknowledgment of the address byte, the bus controller sends a command byte that is stored in the control register in the TCA9847 (see Figure 7-5). This register can be written and read through the I²C bus. Each bit in the command byte corresponds to a SC_n/SD_n channel and a high (or 1) selects this channel. Multiple SC_n/SD_n channels can be selected at the same time. When a channel is selected, the channel becomes active after a stop condition has been placed on the I²C bus. This action makes sure that all SC_n/SD_n lines are in a high state when the channel is made active, so that no false conditions are generated at the time

of connection. A stop condition always must occur immediately after the acknowledge cycle. If multiple bytes are received by the TCA9847, the TCA9847 saves the last byte received.

Channel Selection Bits (Read/Write)

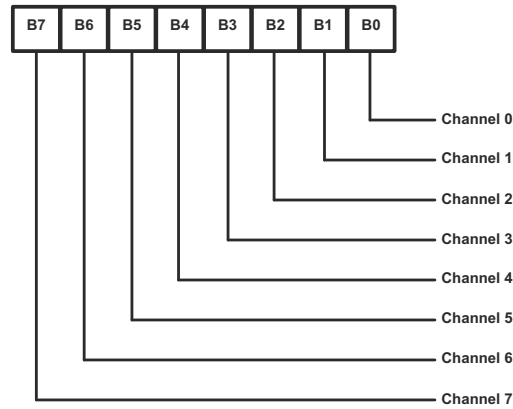

Figure 7-5. Control Register

Table 7-2 shows the TCA9847 Command Byte Definition.

Table 7-2. Command Byte Definition

CONTROL REGISTER BITS								COMMAND
B7	B6	B5	B4	B3	B2	B1	B0	
X	X	X	X	X	X	X	0	Channel 0 disabled
							1	Channel 0 enabled
X	X	X	X	X	X	X	0	Channel 1 disabled
							1	Channel 1 enabled
X	X	X	X	X	X	X	0	Channel 2 disabled
							1	Channel 2 enabled
X	X	X	X	0	X	X	X	Channel 3 disabled
							1	Channel 3 enabled
X	X	X	0	X	X	X	X	Channel 4 disabled
							1	Channel 4 enabled
X	X	0	X	X	X	X	X	Channel 5 disabled
							1	Channel 5 enabled
X	0	X	X	X	X	X	X	Channel 6 disabled
							1	Channel 6 enabled
0	X	X	X	X	X	X	X	Channel 7 disabled
							1	Channel 7 enabled
0	0	0	0	0	0	0	0	No channel selected, power-up/reset default state

7.5.5 $\overline{\text{RESET}}$ Input

The $\overline{\text{RESET}}$ input is an active-low signal that can be used to recover from a bus-fault condition. When this signal is asserted low for a minimum of t_{WL} , the TCA9847 resets the registers and I²C state machine and deselects all channels. The $\overline{\text{RESET}}$ input must be connected to V_{CC} through a pullup resistor.

7.5.6 Power-On Reset

When power (from 0V) is applied to V_{DD} , an internal power-on reset holds the TCA9847 in a reset condition until V_{DD} has reached V_{POR} . At that point, the reset condition is released and the TCA9847 registers and I²C state machine initialize to the default states. After that, V_{CC} must be lowered to below V_{POR} and then back up to the operating voltage for a power-reset cycle.

7.5.7 Software Reset

The software reset call provides a mechanism to return all devices on the I²C bus to the power-up default state by issuing a specifically formatted I²C command. This operation assumes that the I²C bus is operating correctly and that no device is holding the bus in a latched or “hung” condition. The software reset sequence is defined as the following:

1. The I²C controller issues a START condition.
2. The controller transmits the reserved General Call address '0000 000' with the R/W bit set to 0 (write).
3. A device acknowledges only when the device detects the full General Call address 0000 0000 (00h). If the R/W bit is set to 1 (read), no acknowledge is generated.
4. After the General Call address is acknowledged, the controller transmits a single data byte with the value 06h.
 - a. The device acknowledges only when this data byte is equal to 06h.
 - b. If the data byte is not 06h, or if more than one data byte is transmitted, the device does not acknowledge further.
 - c. When the correct byte has been received and acknowledged, the controller must issue a STOP condition to complete the software reset sequence. At this point, the device resets the registers to the power-up default values and becomes ready for subsequent bus transactions after the required bus-free time.
 - d. If a Repeated START condition is issued instead of a STOP, the reset is not performed.
 - e. Any missing acknowledge from the device at any point in this sequence shall be treated by the controller as a Software Reset Abort. In such a case, the device does not initiate any register reset.

7.5.8 Device ID

The Device ID is a 24-bit (3-byte) read-only value containing the following fields:

- 12 bits: Manufacturer identifier (unique per manufacturer, for example, TI)
- 9 bits: Part number (assigned by the manufacturer)
- 3 bits: Die revision (assigned by the manufacturer)

The Device ID is hardwired and accessible using the following procedure:

1. Send a START command.
2. The controller transmits the Reserved Device ID I²C address (1111 1000) with R/W = 0 (write).
3. The controller sends the target device address, with the LSB as “don’t care.” Only the matching device acknowledges.
4. Issue a Repeated START condition.
 - a. A STOP command followed by a START command resets the target state machine and the Device ID read cannot be performed. Also, a STOP command or a Re-START command followed by an access to another target device resets the target state machine and the Device ID Read cannot be performed.
5. The controller sends the Reserved Device ID I²C address (1111 1001) with R/W = 1 (read).
6. The device transmits the Device ID in the following order:
 - a. First byte + 4 MSBs of second byte: Manufacturer ID (12 bits)
 - b. 4 LSBs of second byte + 5 MSBs of third byte: Part Identification (9 bits)
 - c. 3 LSBs of third byte: Die Revision (3 bits)
7. The controller completes the read by sending a NACK after the last byte, resetting the device’s internal state machine and then issuing a STOP command.

If the controller sends additional acknowledgments after the third byte, the device restarts the data sequence from the first byte.

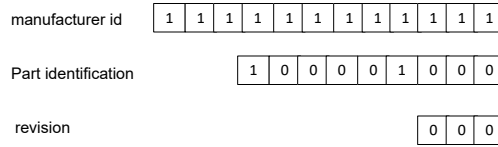
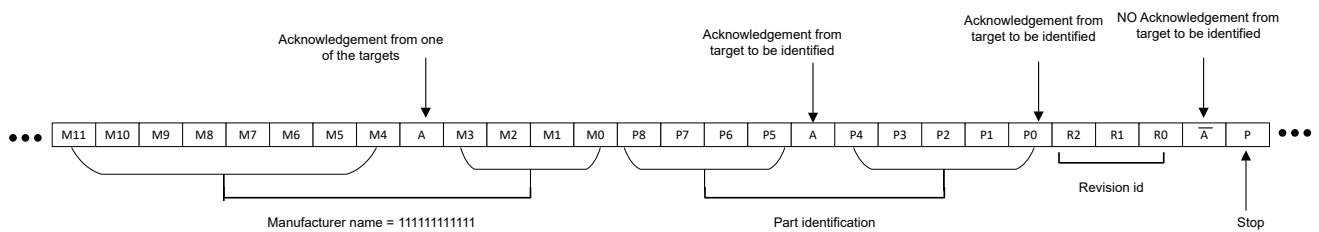
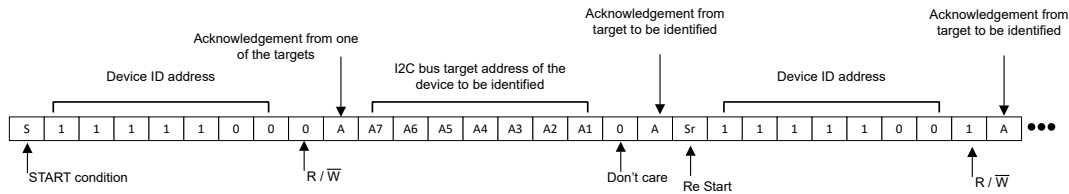

Figure 7-6. Device ID



If more than 3 bytes are read, the target device loops back to the first byte (manufacturer byte) and keeps sending data until the controller generates a 'no acknowledge'.

Figure 7-7. Device ID Sequence

ADVANCE INFORMATION

8 Application and Implementation

Note

Information in the following applications sections is not part of the TI component specification, and TI does not warrant its accuracy or completeness. TI's customers are responsible for determining suitability of components for their purposes, as well as validating and testing their design implementation to confirm system functionality.

8.1 Application Information

Applications of the TCA9847 contain an I²C (or SMBus) controller device and up to eight I²C target devices. The downstream channels are used to resolve I²C target address conflicts. For example, if eight identical digital temperature sensors are needed in the application, one sensor can be connected at each channel: 0-7. When the temperature at a specific location is read, the appropriate channel can be enabled and all other channels switched off, the data can be retrieved, and the I²C controller can move on and read the next channel.

In an application where the I²C bus contains many additional target devices that do not result in I²C target address conflicts, these target devices can be connected to any desired channel to distribute the total bus capacitance across multiple channels. If multiple switches are enabled simultaneously, additional design requirements must be considered (see the [Design Requirements](#) section and [Detailed Design Procedure](#) section).

8.2 Typical Application

Figure 8-1 shows an application in which the TCA9847 can be used.

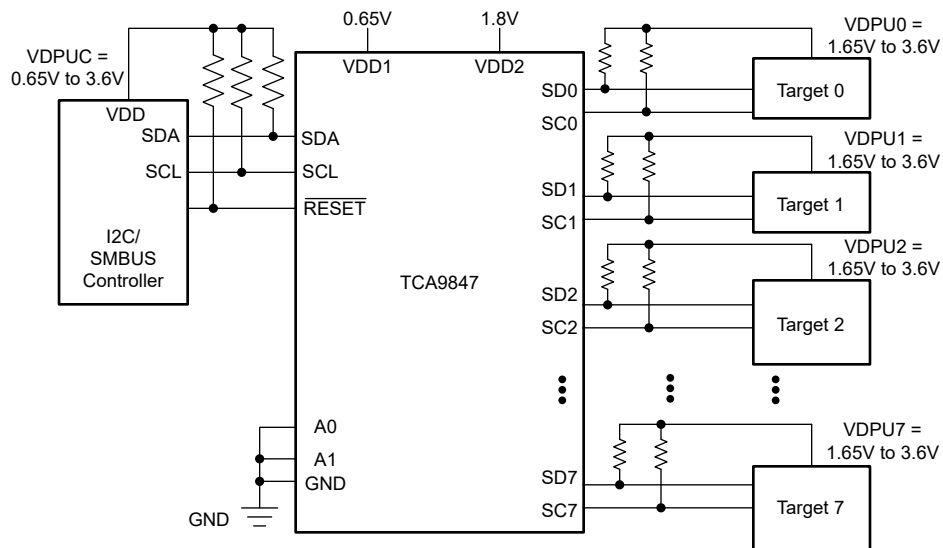

Pin numbers shown are for the PW package.

Figure 8-1. Typical Application Schematic

8.2.1 Design Requirements

A typical application of the TCA9847 contains one or more data pullup voltages, V_{DPUX} , one for the controller device (V_{DPUM}) and one for each of the selectable target channels ($V_{DPU0} - V_{DPU7}$). In the event where the controller device and all target devices operate at the same voltage, then $V_{DPUM} = V_{DPUX} = V_{CC}$. In an application where voltage translation is necessary, additional design requirements must be considered to determine an appropriate V_{CC} voltage.

The A0, A1 pins are hardware selectable to control the target address of the TCA9847. These pins can be tied directly to GND or V_{CC} in the application.

If multiple target channels are activated simultaneously in the application, then the total I_{OL} from SCL/SDA to GND on the controller side is the sum of the currents through all pullup resistors, R_p .

The pass-gate transistors of the TCA9847 are constructed such that the V_{CC} voltage can be used to limit the maximum voltage that is passed from one I²C bus to another.

For the TCA9847 to act as a voltage translator, the V_{pass} voltage must be equal to or lower than the lowest bus voltage.

8.2.1.1 Voltage Translation Requirements

UPSTREAM BUS VOLTAGE OR CONTROLLER PULLUP RESISTOR VOLTAGE V_{DPUX}	TCA98xx VDD1 SUPPLY VOLTAGE	CHANNEL PASS TRANSISTOR CLAMP VOLTAGE	TCA98xx VDD2 SUPPLY VOLTAGE	LOWEST DOWNSTREAM BUS VOLTAGE V_{DPUx}	COMMENTS
0.65	0.65	0.65	1.65-3.6	0.65-3.6	OK
1.8-3.6	0.65	0.65	1.65-3.6	0.65	OK
1.8	1.8	1.8	1.8-3.6	1.8-3.6	OK
2.5	2.5	1.8	1.8	1.8	OK
2.5	2.5	2.5	2.3-3.6	2.3-3.6	OK
3.6	3.6	1.8	1.8	1.8	OK
3.6	3.6	2.5	2.5	2.5	OK
3.6	3.6	3.6	3.6	3.6	OK
1.8	1.8	1.8	1.8	0.65	NOT OK
2.5	2.5	1.8	1.8	0.65	NOT OK
3.6	3.6	1.8	1.8	0.65	NOT OK

There is no buffering capability between the upstream and the downstream buses. This is simply a pass transistor, which acts like a multiplexer and a series resistor, between these bus segment

8.2.2 Detailed Design Procedure

After all the targets are assigned to the appropriate target channels and bus voltages are identified, the pullup resistors, R_p , for each of the buses need to be selected appropriately. The minimum pullup resistance is a function of V_{DPUX} , $V_{OL(max)}$, and I_{OL} as shown in [Equation 1](#):

$$R_{p(min)} = \frac{V_{DPUX} - V_{OL(max)}}{I_{OL}} \quad (1)$$

The maximum pullup resistance is a function of the maximum rise time, t_r (300ns for fast-mode operation, $f_{SCL} = 400kHz$) and bus capacitance, C_b as shown in [Equation 2](#):

$$R_{p(max)} = \frac{t_r}{0.8473 \times C_b} \quad (2)$$

The maximum bus capacitance for an I²C bus must not exceed 400pF for fast-mode operation. The bus capacitance can be approximated by adding the capacitance of the TCA9847, C_{io(OFF)}, the capacitance of wires, connections and traces, and the capacitance of each individual target on a given channel. If multiple channels are activated simultaneously, each of the targets on all channels contribute to total bus capacitance.

8.3 Power Supply Recommendations

The operating power-supply voltage range of the TCA9847 is 0.65V to 3.6V for VDD1 and 1.65-3.6V for VDD2. Whenever the TCA9847 is powered on, the device executes a power-on reset. Make sure the power supply sequencing follows the power-on reset requirements given below. The power-on reset requirements must be followed to make sure the I²C bus logic is initialized properly.

8.3.1 Power-On Reset Requirements

In the event of a glitch or data corruption, TCA9847 can be reset to the default conditions by using the power-on reset feature. Power-on reset requires that the device go through a power cycle to be completely reset. This reset also happens when the device is powered on for the first time in an application.

A power-on reset is shown in Figure 8-2.

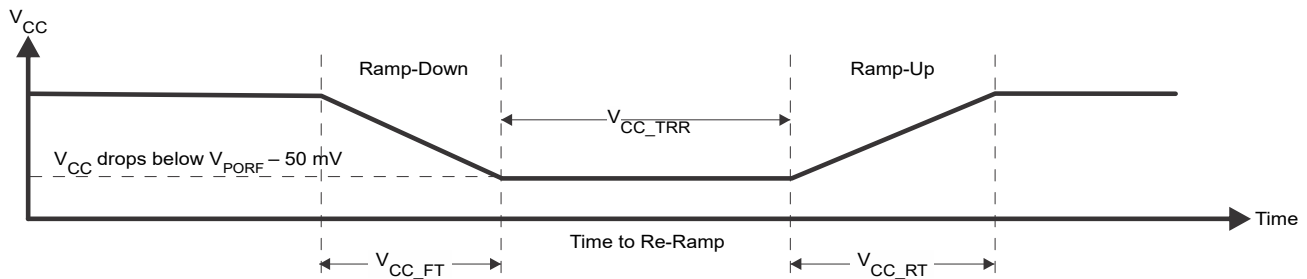

V_{CC} is Lowered Below the POR Threshold, Then Ramped Back Up to V_{CC}

Figure 8-2. Power-On Reset Waveform

Table 8-1 specifies the performance of the power-on reset feature for TCA9847 for both types of power-on reset.

Table 8-1. Recommended Supply Sequencing and Ramp Rates ⁽¹⁾

PARAMETER			MIN	MAX	UNIT
V _{CC_FT}	Fall time	See Figure 8-2	0.1	2000	ms
V _{CC_RT}	Rise time	See Figure 8-2	0.1	2000	ms
V _{CC_TRR}	Time to re-ramp (when V _{CC} drops below V _{PORF(min)} – 50mV or when V _{CC} drops to GND)	See Figure 8-2	10		µs
V _{CC_GH}	Level that V _{CC} can glitch down to, but not cause a functional disruption when V _{CC_GW} = 1µs	See Figure 8-3		1	V
V _{CC_GW}	Glitch width that does not cause a functional disruption when V _{CC_GH} = 0.5 × V _{CC}	See Figure 8-3		10	µs

(1) All supply sequencing and ramp rate values are measured at T_A = 25°C

Glitches in the power supply can also affect the power-on reset performance of this device. The glitch width (V_{CC_GW}) and height (V_{CC_GH}) are dependent on each other. The bypass capacitance, source impedance, and device impedance are factors that affect power-on reset performance. Figure 8-3 and Table 8-1 provide more information on how to measure these specifications.

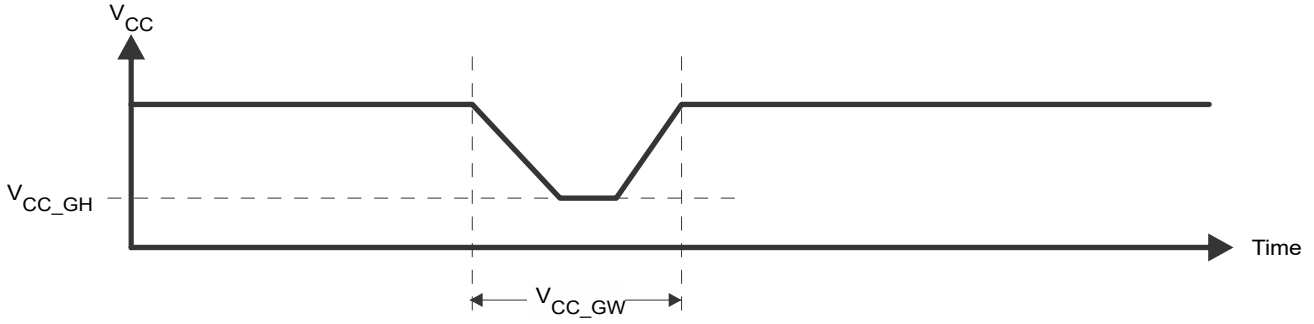

Figure 8-3. Glitch Width and Glitch Height

V_{POR} is critical to the power-on reset. V_{POR} is the voltage level at which the reset condition is released and all the registers and the I²C/SMBus state machine are initialized to the default states. The value of V_{POR} differs based on the V_{CC} being lowered to or from 0. [Figure 8-4](#) and [Table 8-1](#) provide more details on this specification.

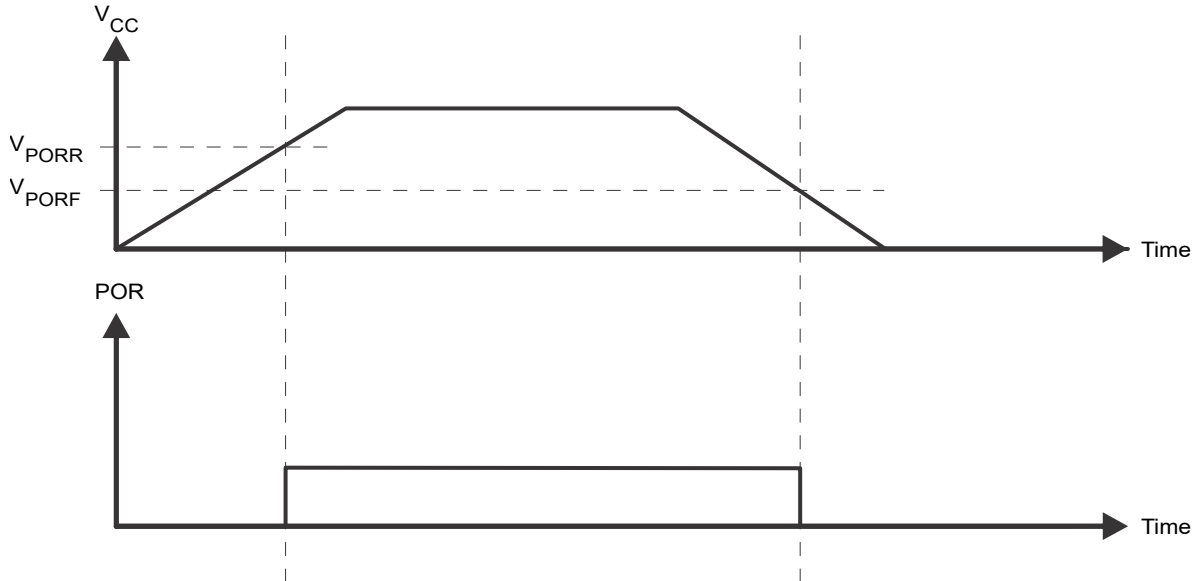

Figure 8-4. V_{POR}

8.4 Layout

8.4.1 Layout Guidelines

For PCB layout of the TCA9847, common PCB layout practices must be followed but additional concerns related to high-speed data transfer such as matched impedances and differential pairs are not a concern for I²C signal speeds. Having a dedicated ground plane on an inner layer of the board is common, and pins that are connected to ground must have a low-impedance path to the ground plane in the form of wide polygon pours and multiple vias. By-pass and decoupling capacitors are commonly used to control the voltage on the VCC pin, using a larger capacitor to provide additional power in the event of a short power supply glitch and a smaller capacitor to filter out high-frequency ripple.

In an application where voltage translation is not required, all V_{DPUX} voltages and V_{CC} can be at the same potential and a single copper plane can connect all of pullup resistors to the appropriate reference voltage. In an application where voltage translation is required, V_{DPUM} and V_{DPU0} – V_{DPU7}, can all be on the same layer of the board with split planes to isolate different voltage potentials.

To reduce the total I²C bus capacitance added by PCB parasitics, data lines (SC_n and SD_n) must be as short as possible and the widths of the traces must also be minimized (for example, 5-10 mils depending on copper weight).

8.4.2 Layout Example

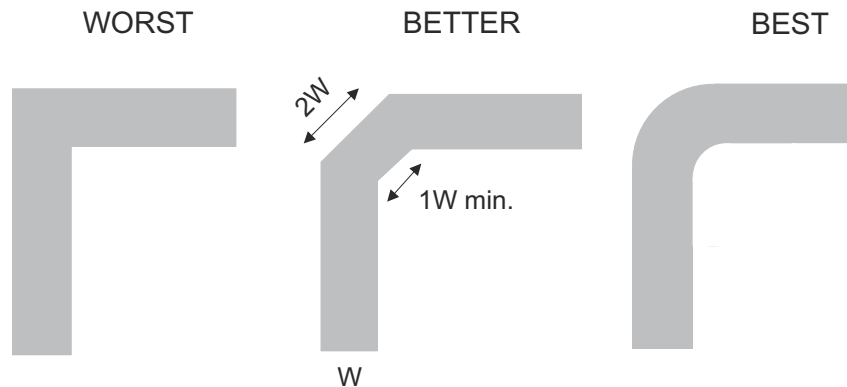

Figure 8-5. Layout Schematic

9 Device and Documentation Support

9.1 Documentation Support

9.1.1 Related Documentation

For related documentation, see the following:

- Texas Instruments, [I2C Bus Pullup Resistor Calculation](#) application note
- Texas Instruments, [Maximum Clock Frequency of I2C Bus Using Repeaters](#) application note
- Texas Instruments, [Understanding the I2C Bus](#) application note
- Texas Instruments, [Choosing the Correct I2C Device for New Designs](#) application note
- Texas Instruments, [TCA9548AEVM EVM user's guide](#)

9.2 Receiving Notification of Documentation Updates

To receive notification of documentation updates, navigate to the device product folder on ti.com. Click on *Notifications* to register and receive a weekly digest of any product information that has changed. For change details, review the revision history included in any revised document.

9.3 Support Resources

[TI E2E™ support forums](#) are an engineer's go-to source for fast, verified answers and design help — straight from the experts. Search existing answers or ask your own question to get the quick design help you need.

Linked content is provided "AS IS" by the respective contributors. They do not constitute TI specifications and do not necessarily reflect TI's views; see TI's [Terms of Use](#).

9.4 Trademarks

TI E2E™ is a trademark of Texas Instruments.
All trademarks are the property of their respective owners.

9.5 Electrostatic Discharge Caution



This integrated circuit can be damaged by ESD. Texas Instruments recommends that all integrated circuits be handled with appropriate precautions. Failure to observe proper handling and installation procedures can cause damage.

ESD damage can range from subtle performance degradation to complete device failure. Precision integrated circuits may be more susceptible to damage because very small parametric changes could cause the device not to meet its published specifications.

9.6 Glossary

[TI Glossary](#) This glossary lists and explains terms, acronyms, and definitions.

10 Revision History

DATE	REVISION	NOTES
April 2026	*	Initial Release

11 Mechanical, Packaging, and Orderable Information

The following pages include mechanical, packaging, and orderable information. This information is the most current data available for the designated devices. This data is subject to change without notice and revision of this document. For browser-based versions of this data sheet, refer to the left-hand navigation.

11.1 Tape and Reel Information

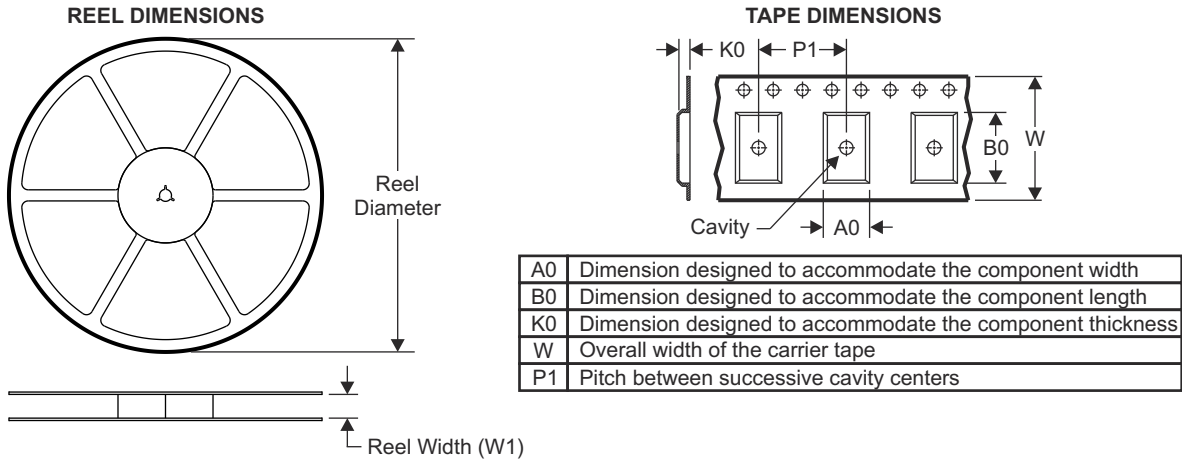

QUADRANT ASSIGNMENTS FOR PIN 1 ORIENTATION IN TAPE

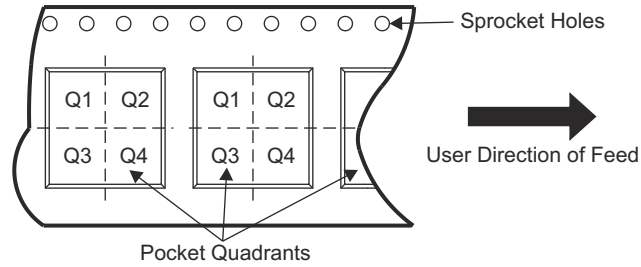

Device	Package Type	Package Drawing	Pins	SPQ	Reel Diameter (mm)	Reel Width W1 (mm)	A0 (mm)	B0 (mm)	K0 (mm)	P1 (mm)	W (mm)	Pin1 Quadrant
TCA9847RGER	VQFN	RGE	24	3000	330	12.4	4.25	4.25	1.15	8	12	Q2
TCA9847PWR	TSSOP	PW	24	3000	330	16.4	6.95	8.30	1.60	8	16	Q1

ADVANCE INFORMATION

TAPE AND REEL BOX DIMENSIONS

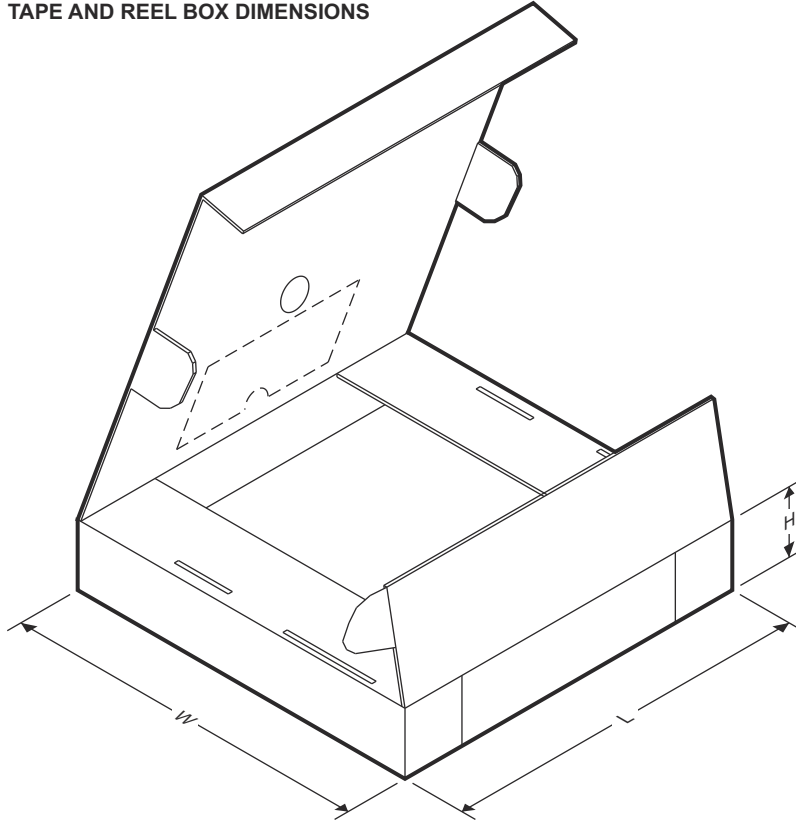

Device	Package Type	Package Drawing	Pins	SPQ	Length (mm)	Width (mm)	Height (mm)
TCA9847RGER	VQFN	RGE	24	3000	346	346	33
TCA9847PWR	TSSOP	PW	24	3000	353	353	32

ADVANCE INFORMATION

11.2 Mechanical Data

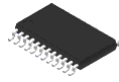

PW0024A

PACKAGE OUTLINE

TSSOP - 1.2 mm max height

SMALL OUTLINE PACKAGE

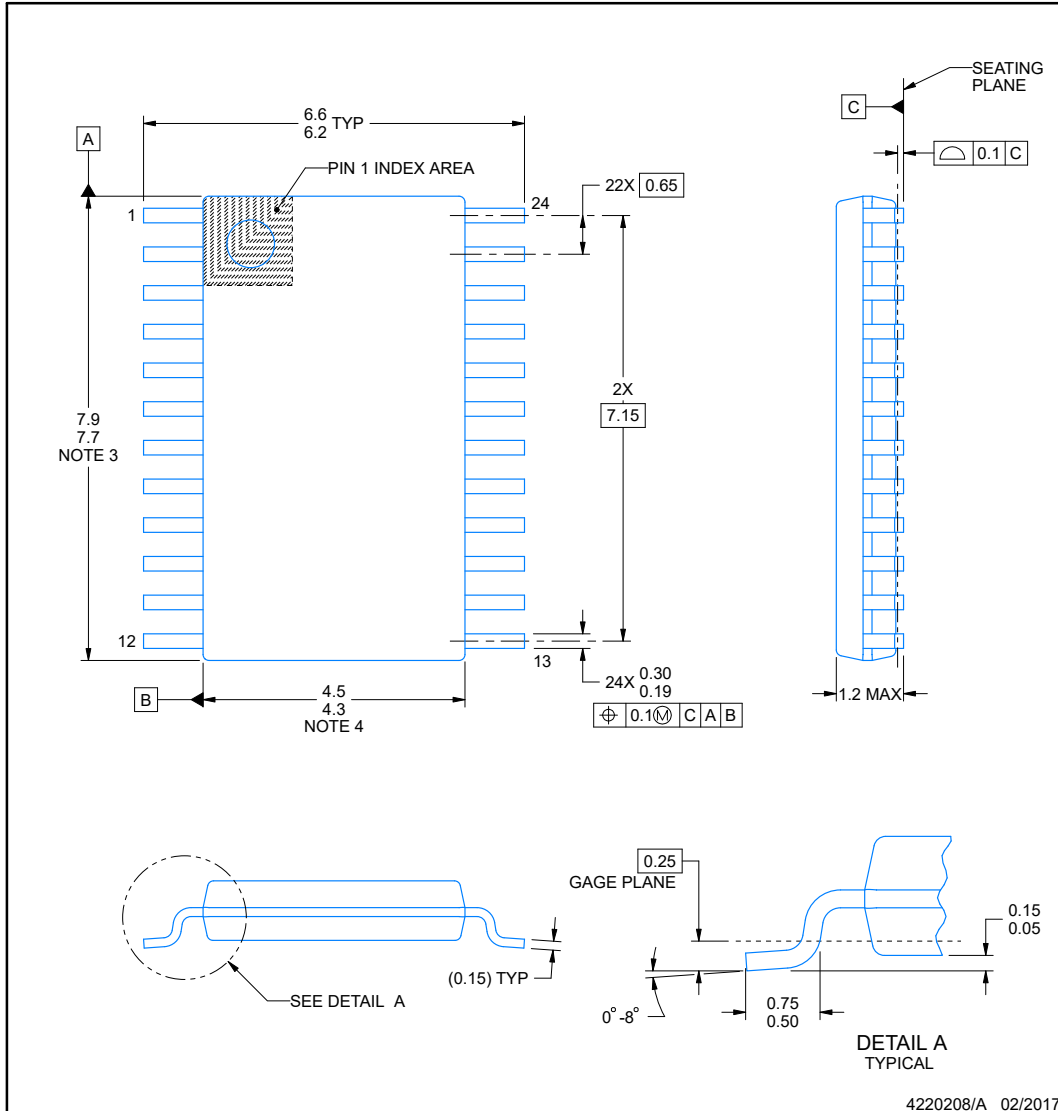

NOTES:

1. All linear dimensions are in millimeters. Any dimensions in parenthesis are for reference only. Dimensioning and tolerancing per ASME Y14.5M.
2. This drawing is subject to change without notice.
3. This dimension does not include mold flash, protrusions, or gate burrs. Mold flash, protrusions, or gate burrs shall not exceed 0.15 mm per side.
4. This dimension does not include interlead flash. Interlead flash shall not exceed 0.25 mm per side.
5. Reference JEDEC registration MO-153.

EXAMPLE BOARD LAYOUT

PW0024A

TSSOP - 1.2 mm max height

SMALL OUTLINE PACKAGE

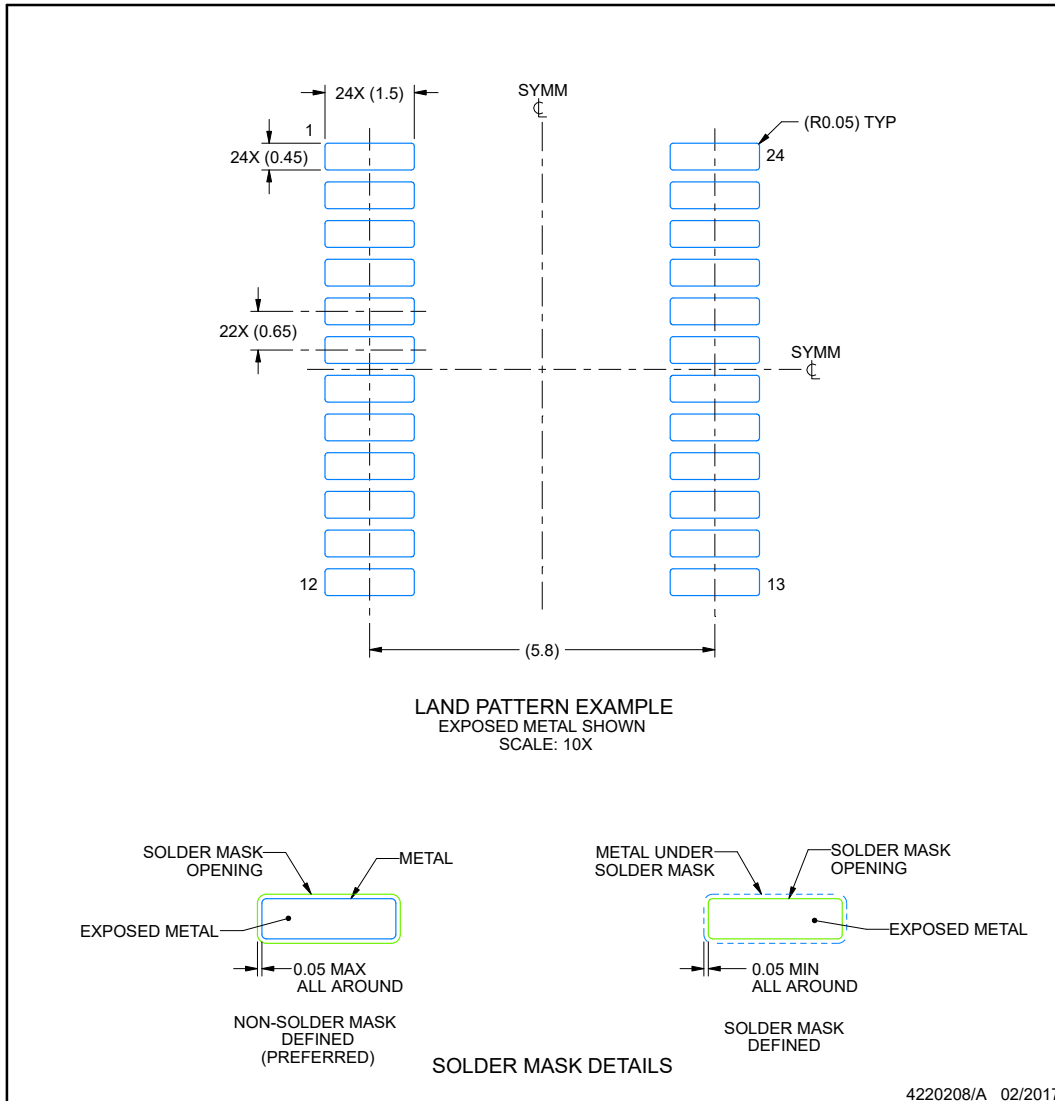

NOTES: (continued)

- 6. Publication IPC-7351 may have alternate designs.
- 7. Solder mask tolerances between and around signal pads can vary based on board fabrication site.

EXAMPLE STENCIL DESIGN

PW0024A

TSSOP - 1.2 mm max height

SMALL OUTLINE PACKAGE

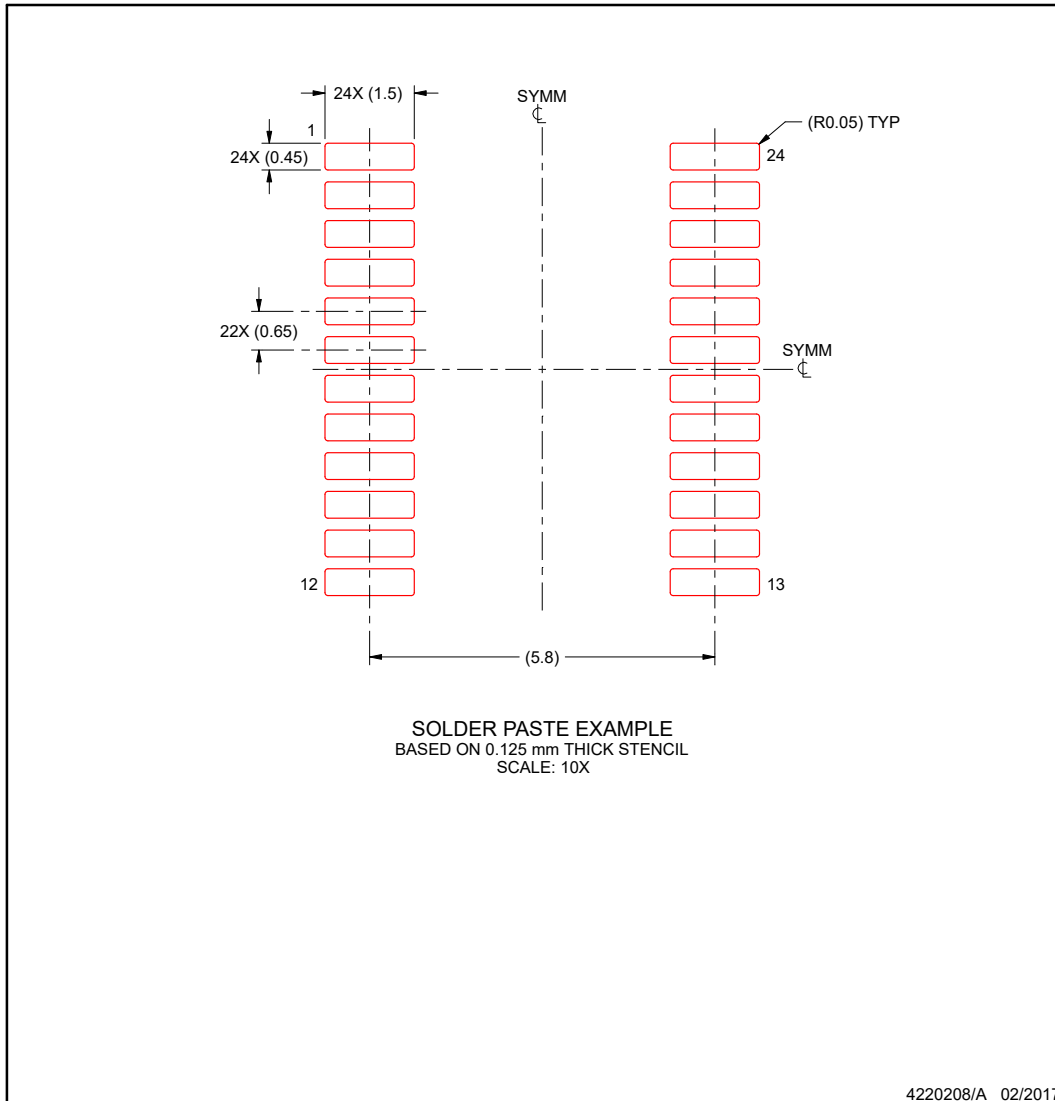

NOTES: (continued)

8. Laser cutting apertures with trapezoidal walls and rounded corners may offer better paste release. IPC-7525 may have alternate design recommendations.
9. Board assembly site may have different recommendations for stencil design.

ADVANCE INFORMATION

RGE0024C **PACKAGE OUTLINE**
VQFN - 1 mm max height

PLASTIC QUAD FLATPACK- NO LEAD

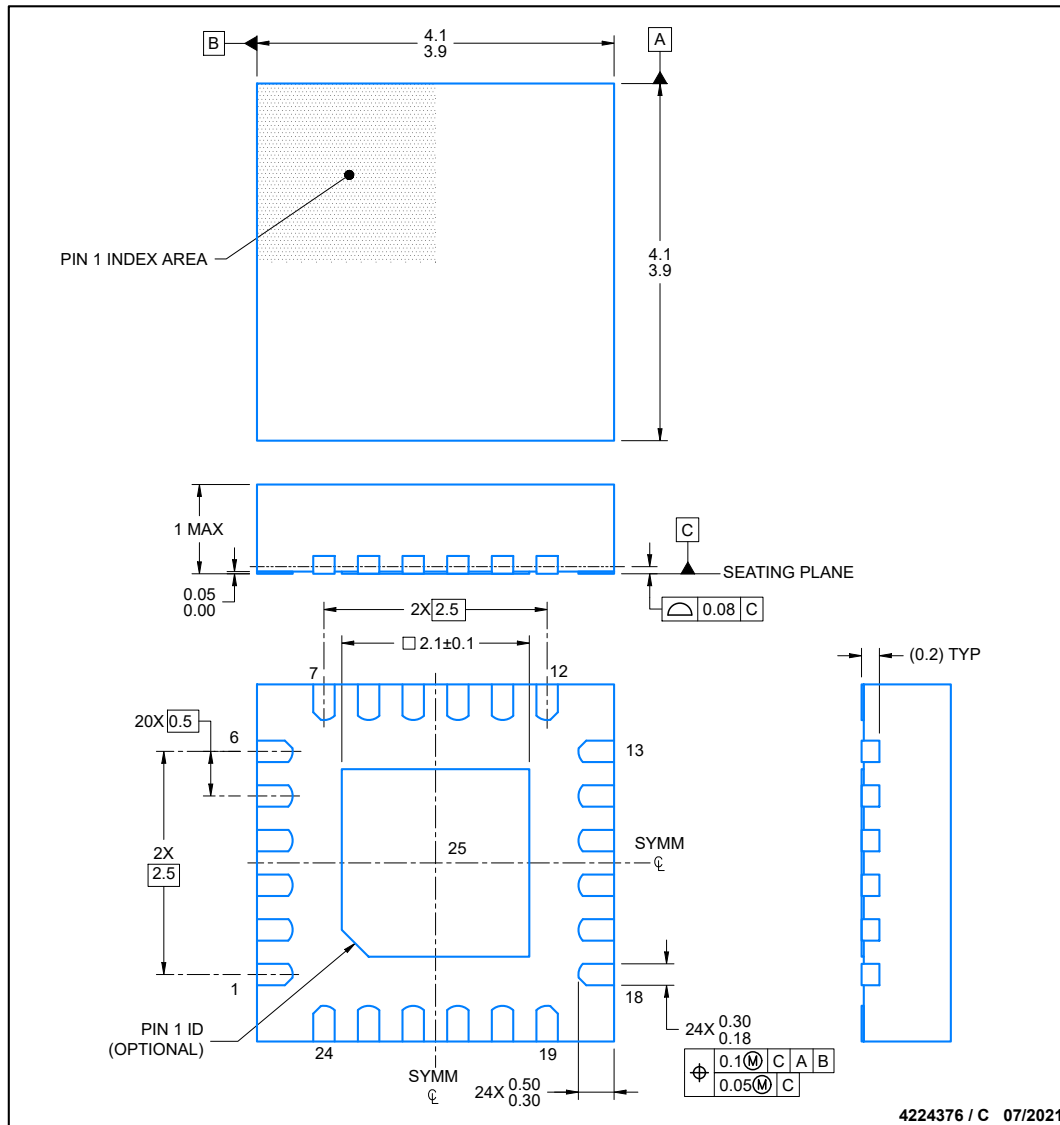

NOTES:

1. All linear dimensions are in millimeters. Any dimensions in parenthesis are for reference only. Dimensioning and tolerancing per ASME Y14.5M.
2. This drawing is subject to change without notice.
3. The package thermal pad must be soldered to the printed circuit board for thermal and mechanical performance.

EXAMPLE BOARD LAYOUT
VQFN - 1 mm max height

RGE0024C

PLASTIC QUAD FLATPACK- NO LEAD

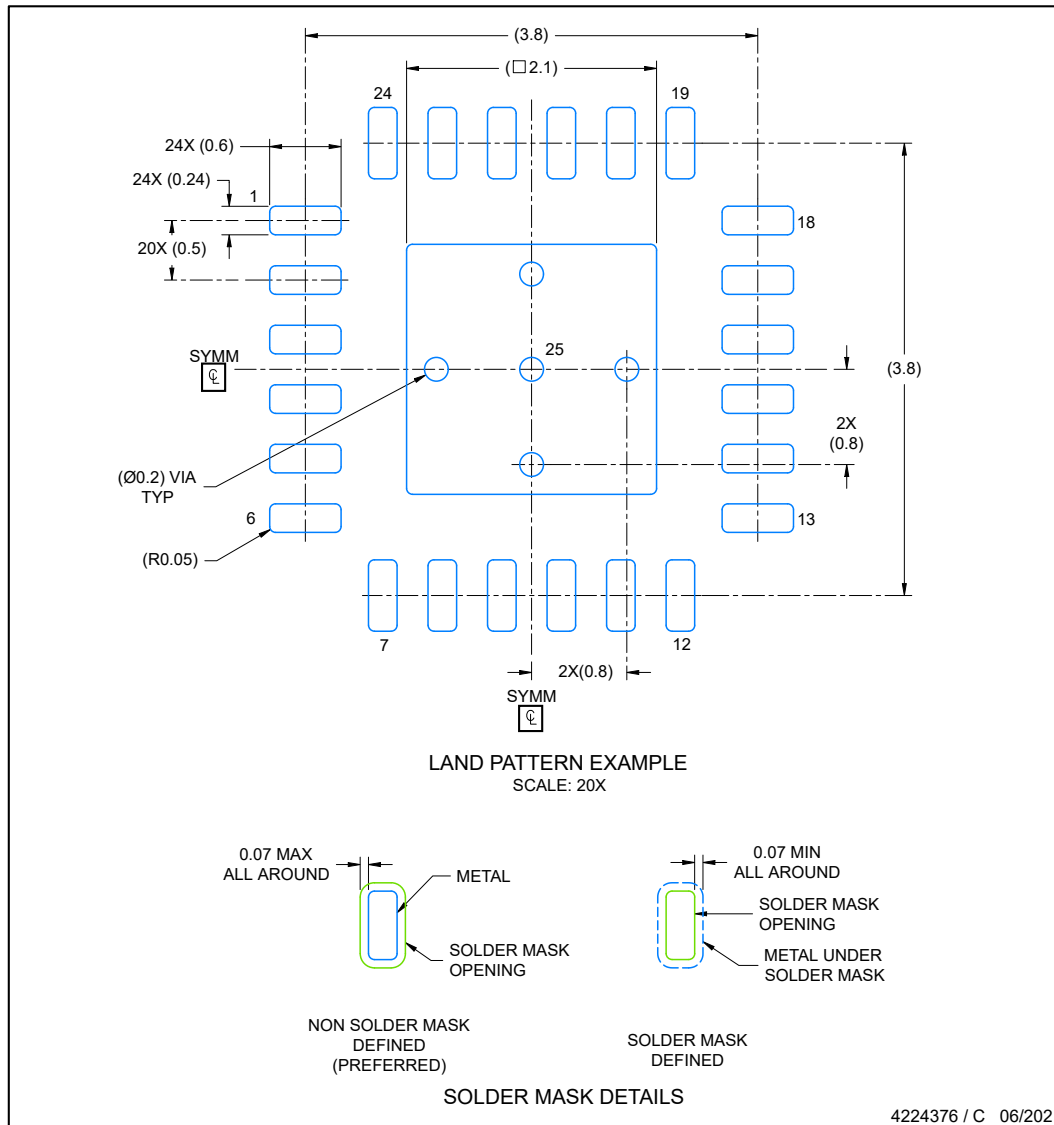

NOTES: (continued)

4. This package is designed to be soldered to a thermal pad on the board. For more information, see Texas Instruments literature number SLUA271 (www.ti.com/lit/slua271).
5. Solder mask tolerances between and around signal pads can vary based on board fabrication site.

ADVANCE INFORMATION

EXAMPLE STENCIL DESIGN

RGE0024C

VQFN - 1 mm max height

PLASTIC QUAD FLATPACK- NO LEAD

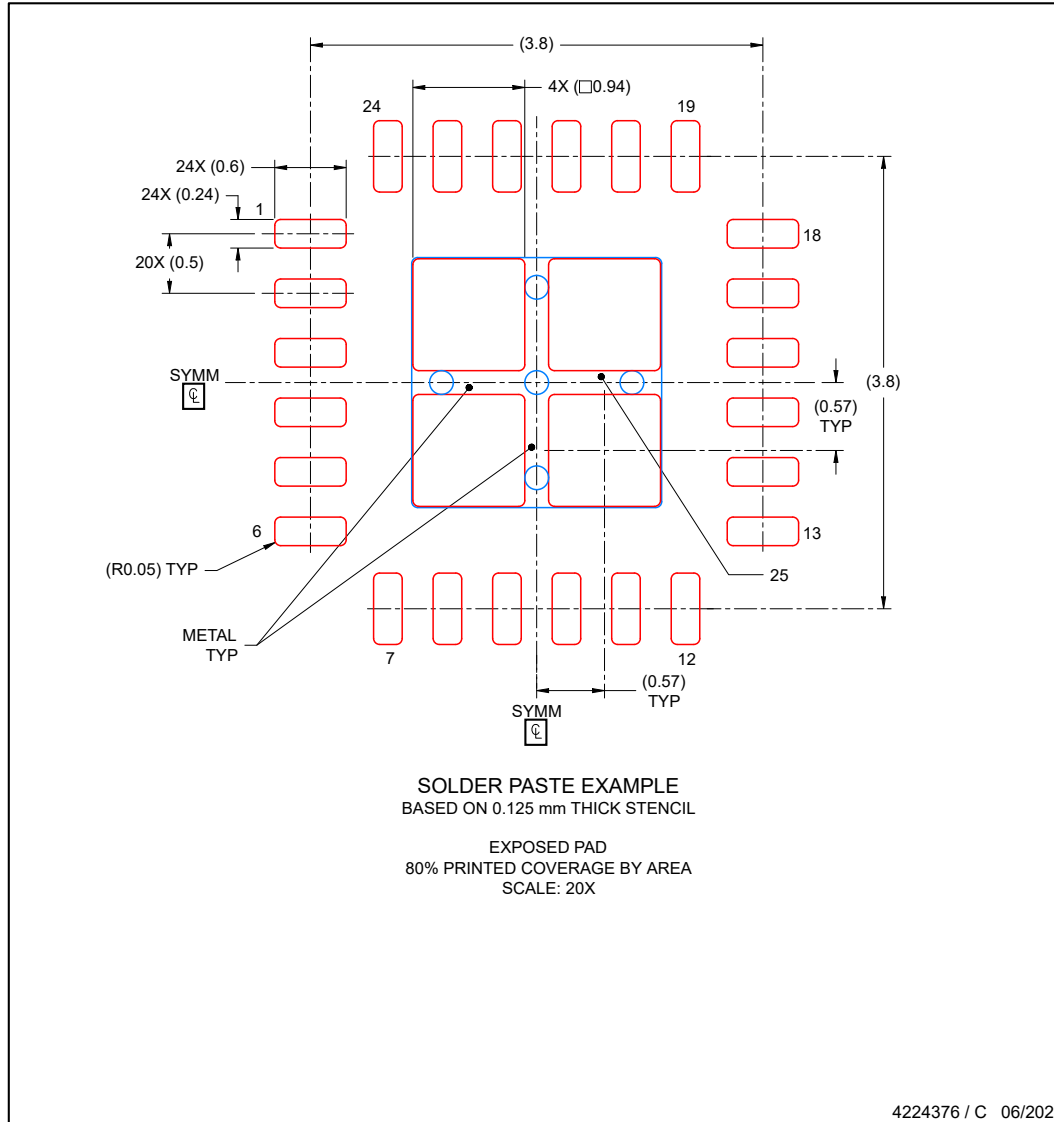

NOTES: (continued)

- 6. Laser cutting apertures with trapezoidal walls and rounded corners may offer better paste release. IPC-7525 may have alternate design recommendations..

PACKAGING INFORMATION

Orderable part number	Status (1)	Material type (2)	Package Pins	Package qty Carrier	RoHS (3)	Lead finish/ Ball material (4)	MSL rating/ Peak reflow (5)	Op temp (°C)	Part marking (6)
PTCA9847PWR	Active	Preproduction	TSSOP (PW) 24	3000 LARGE T&R	-	Call TI	Call TI	-40 to 125	
PTCA9847RGER	Active	Preproduction	VQFN (RGE) 24	3000 LARGE T&R	-	Call TI	Call TI	-40 to 125	
TCA9847PWR	Active	Production	TSSOP (PW) 24	3000 LARGE T&R	Yes	NIPDAU	Level-1-260C-UNLIM	-40 to 125	TCA9847

(1) **Status:** For more details on status, see our [product life cycle](#).

(2) **Material type:** When designated, preproduction parts are prototypes/experimental devices, and are not yet approved or released for full production. Testing and final process, including without limitation quality assurance, reliability performance testing, and/or process qualification, may not yet be complete, and this item is subject to further changes or possible discontinuation. If available for ordering, purchases will be subject to an additional waiver at checkout, and are intended for early internal evaluation purposes only. These items are sold without warranties of any kind.

(3) **RoHS values:** Yes, No, RoHS Exempt. See the [TI RoHS Statement](#) for additional information and value definition.

(4) **Lead finish/Ball material:** Parts may have multiple material finish options. Finish options are separated by a vertical ruled line. Lead finish/Ball material values may wrap to two lines if the finish value exceeds the maximum column width.

(5) **MSL rating/Peak reflow:** The moisture sensitivity level ratings and peak solder (reflow) temperatures. In the event that a part has multiple moisture sensitivity ratings, only the lowest level per JEDEC standards is shown. Refer to the shipping label for the actual reflow temperature that will be used to mount the part to the printed circuit board.

(6) **Part marking:** There may be an additional marking, which relates to the logo, the lot trace code information, or the environmental category of the part.

Multiple part markings will be inside parentheses. Only one part marking contained in parentheses and separated by a "-" will appear on a part. If a line is indented then it is a continuation of the previous line and the two combined represent the entire part marking for that device.

Important Information and Disclaimer: The information provided on this page represents TI's knowledge and belief as of the date that it is provided. TI bases its knowledge and belief on information provided by third parties, and makes no representation or warranty as to the accuracy of such information. Efforts are underway to better integrate information from third parties. TI has taken and continues to take reasonable steps to provide representative and accurate information but may not have conducted destructive testing or chemical analysis on incoming materials and chemicals. TI and TI suppliers consider certain information to be proprietary, and thus CAS numbers and other limited information may not be available for release.

In no event shall TI's liability arising out of such information exceed the total purchase price of the TI part(s) at issue in this document sold by TI to Customer on an annual basis.

EXAMPLE BOARD LAYOUT

PW0024A

TSSOP - 1.2 mm max height

SMALL OUTLINE PACKAGE

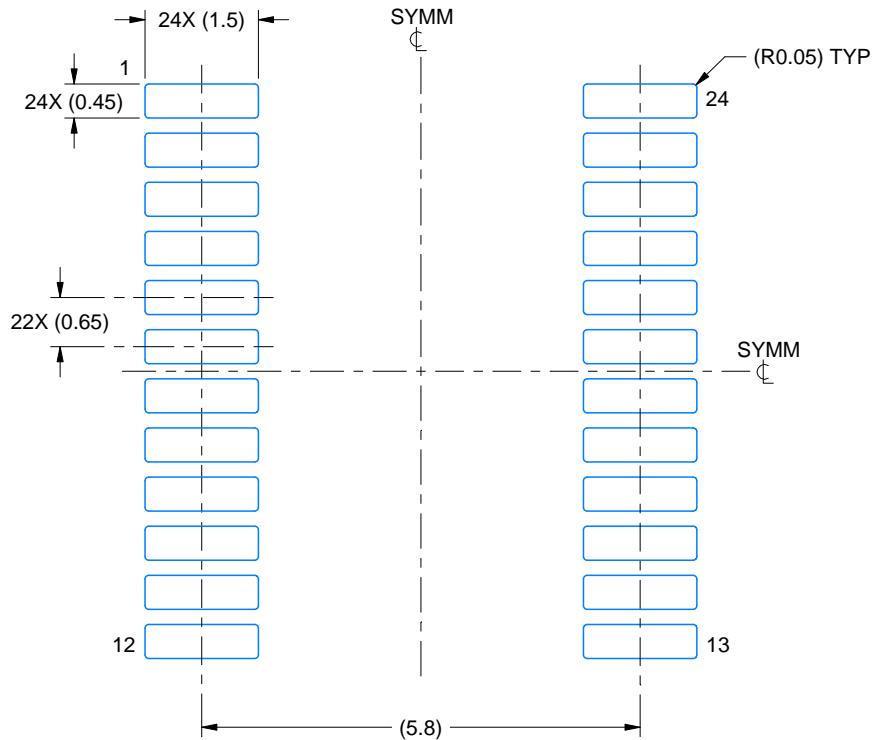

LAND PATTERN EXAMPLE
EXPOSED METAL SHOWN
SCALE: 10X

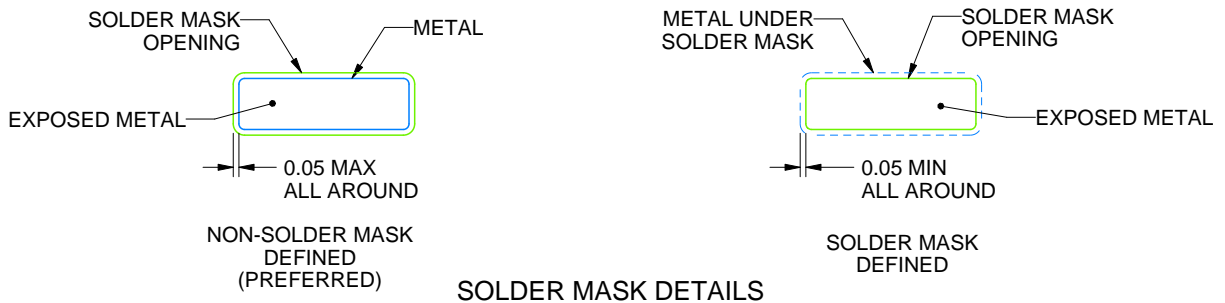

SOLDER MASK DETAILS

4220208/A 02/2017

NOTES: (continued)

- 6. Publication IPC-7351 may have alternate designs.
- 7. Solder mask tolerances between and around signal pads can vary based on board fabrication site.

EXAMPLE STENCIL DESIGN

PW0024A

TSSOP - 1.2 mm max height

SMALL OUTLINE PACKAGE

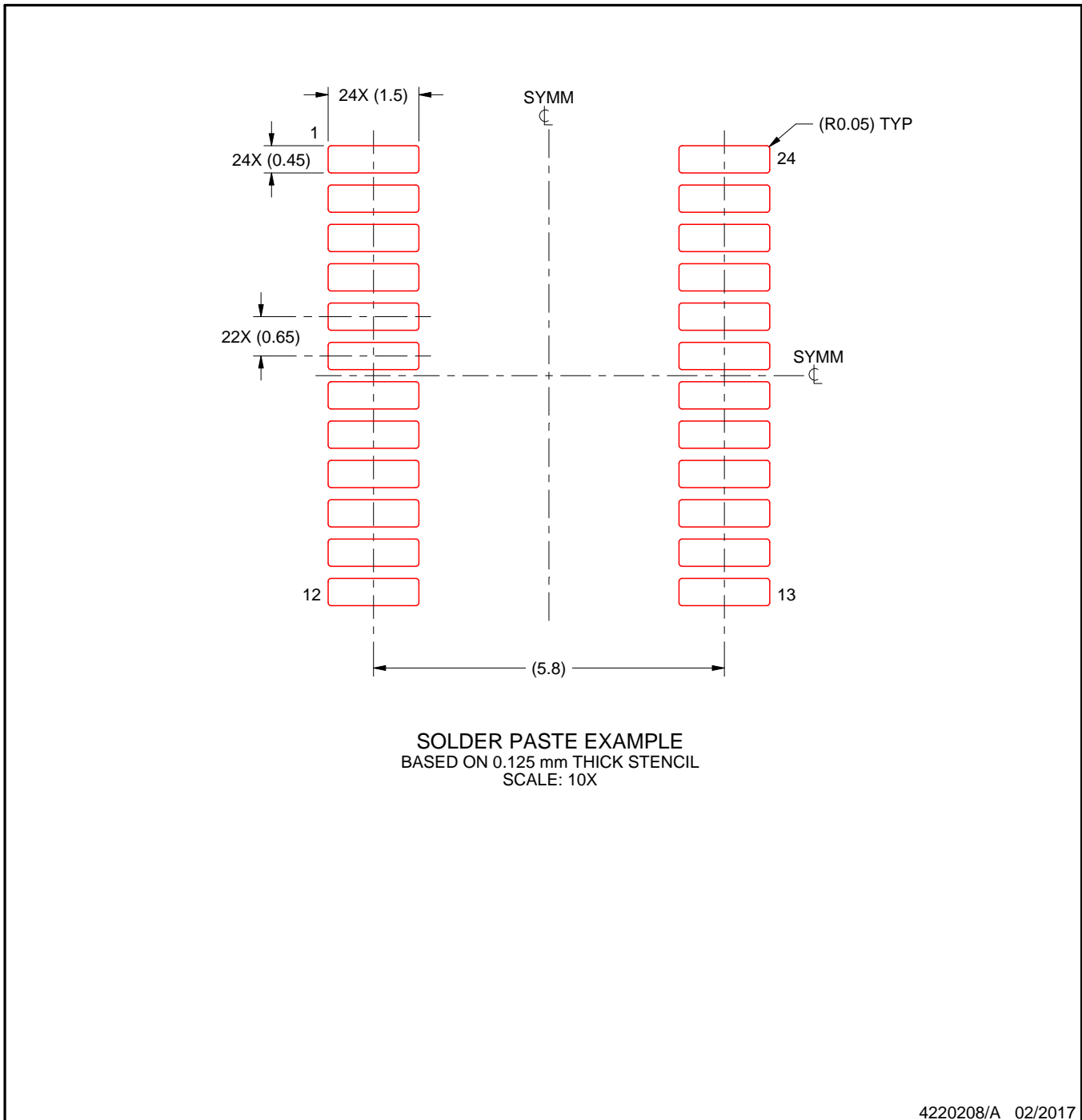

NOTES: (continued)

8. Laser cutting apertures with trapezoidal walls and rounded corners may offer better paste release. IPC-7525 may have alternate design recommendations.
9. Board assembly site may have different recommendations for stencil design.

RGE 24

GENERIC PACKAGE VIEW

VQFN - 1 mm max height

PLASTIC QUAD FLATPACK - NO LEAD



Images above are just a representation of the package family, actual package may vary.
Refer to the product data sheet for package details.

4204104/H

IMPORTANT NOTICE AND DISCLAIMER

TI PROVIDES TECHNICAL AND RELIABILITY DATA (INCLUDING DATASHEETS), DESIGN RESOURCES (INCLUDING REFERENCE DESIGNS), APPLICATION OR OTHER DESIGN ADVICE, WEB TOOLS, SAFETY INFORMATION, AND OTHER RESOURCES "AS IS" AND WITH ALL FAULTS, AND DISCLAIMS ALL WARRANTIES, EXPRESS AND IMPLIED, INCLUDING WITHOUT LIMITATION ANY IMPLIED WARRANTIES OF MERCHANTABILITY, FITNESS FOR A PARTICULAR PURPOSE OR NON-INFRINGEMENT OF THIRD PARTY INTELLECTUAL PROPERTY RIGHTS.

These resources are intended for skilled developers designing with TI products. You are solely responsible for (1) selecting the appropriate TI products for your application, (2) designing, validating and testing your application, and (3) ensuring your application meets applicable standards, and any other safety, security, regulatory or other requirements.

These resources are subject to change without notice. TI grants you permission to use these resources only for development of an application that uses the TI products described in the resource. Other reproduction and display of these resources is prohibited. No license is granted to any other TI intellectual property right or to any third party intellectual property right. TI disclaims responsibility for, and you fully indemnify TI and its representatives against any claims, damages, costs, losses, and liabilities arising out of your use of these resources.

TI's products are provided subject to [TI's Terms of Sale](#), [TI's General Quality Guidelines](#), or other applicable terms available either on [ti.com](#) or provided in conjunction with such TI products. TI's provision of these resources does not expand or otherwise alter TI's applicable warranties or warranty disclaimers for TI products. Unless TI explicitly designates a product as custom or customer-specified, TI products are standard, catalog, general purpose devices.

TI objects to and rejects any additional or different terms you may propose.

Copyright © 2026, Texas Instruments Incorporated

Last updated 10/2025