

TMP821 Two-Phase Half-Wave Motor Predriver

1 Features

- Built-In Lock Detection and Rotational Speed Sensing Mechanisms
- Compact 8-Pin Package Reduces Number of External Components Required
- Automatic Restart When Motor Lock Is Undone
- Hall Amplifier Inputs Have Hysteresis

2 Applications

Small Server Fans

3 Description

The TMP821 device is a two-phase half-wave motor predriver that is suited for fan motors, which has winding in push-pull configuration. It uses differential hall effect sensors for commutation signals for two of the switches in power circuit. The device has a very small pin count, making it very simple to use.

Device Information⁽¹⁾

PART NUMBER	PACKAGE	BODY SIZE (NOM)
TMP821	SOIC (8)	4.90 mm x 3.91 mm

(1) For all available packages, see the orderable addendum at the end of the data sheet.

Block Diagram

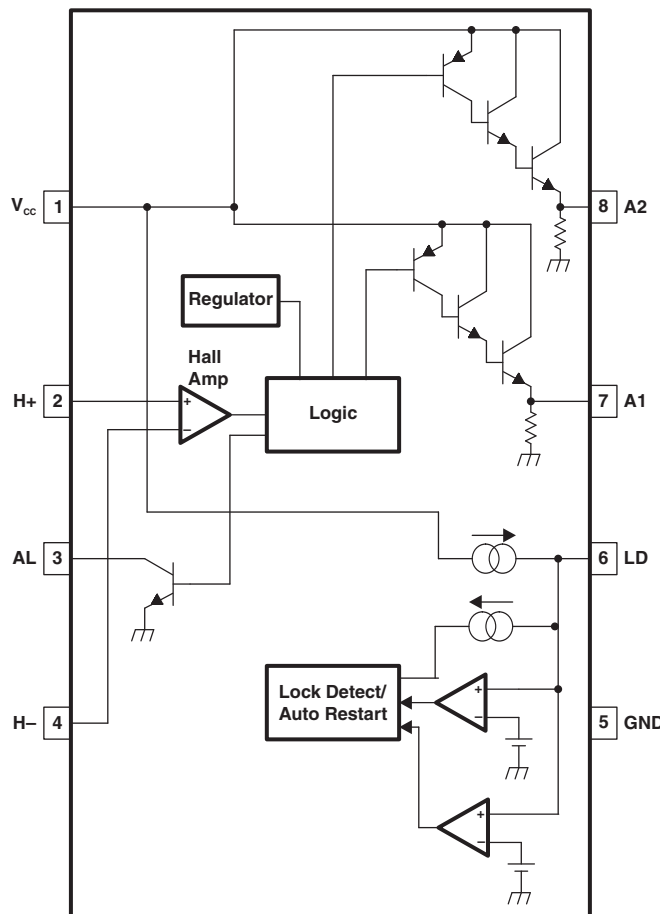

Table of Contents

1 Features 1 2 Applications 1 3 Description 1 4 Revision History 2 5 Pin Configuration and Functions 3 6 Specifications 4 6.1 Absolute Maximum Ratings 4 6.2 ESD Ratings..... 4 6.3 Recommended Operating Conditions 4 6.4 Thermal Information 4 6.5 Electrical Characteristics..... 5 6.6 Typical Characteristics 5 7 Detailed Description 6 7.1 Overview 6 7.2 Functional Block Diagram 6 7.3 Feature Description..... 7	7.4 Device Functional Modes..... 8 8 Application and Implementation 9 8.1 Application Information..... 9 8.2 Typical Application 9 9 Power Supply Recommendations 11 10 Layout 11 10.1 Layout Guidelines 11 10.2 Layout Example 11 10.3 Power Dissipation 11 11 Device and Documentation Support 13 11.1 Community Resource..... 13 11.2 Trademarks 13 11.3 Electrostatic Discharge Caution..... 13 11.4 Glossary 13 12 Mechanical, Packaging, and Orderable Information 13
--	--

4 Revision History

Changes from Original (January 2008) to Revision A

Page

<ul style="list-style-type: none"> • Added <i>ESD Ratings</i> table, <i>Feature Description</i> section, <i>Device Functional Modes</i>, <i>Application and Implementation</i> section, <i>Power Supply Recommendations</i> section, <i>Layout</i> section, <i>Device and Documentation Support</i> section, and <i>Mechanical, Packaging, and Orderable Information</i> section 	1
---	----------

5 Pin Configuration and Functions

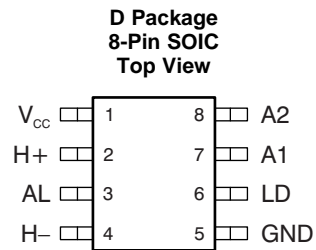

Pin Functions

PIN		I/O	DESCRIPTION
NAME	NO.		
A1	7	O	Driver output
A2	8	O	Driver output
AL	3	O	Speed indication
GND	5	Power GND	Ground
H+	2	I	Positive Hall input
H-	4	I	Negative Hall input
LD	6	I	Timing capacitor
VCC	1	Power Supply	Power input (4 V to 28 V)

6 Specifications

6.1 Absolute Maximum Ratings

over operating free-air temperature range (unless otherwise noted)⁽¹⁾

		MIN	MAX	UNIT
V _{CC}	Supply voltage		30	V
V _{AL}	Output voltage (AL)		30	V
I _{OUT}	Continuous output current (A1, A2)		70	mA
I _{AL}	Continuous output current (AL)		8	mA
T _J	Operating junction temperature	–40	125	°C
T _{stg}	Storage temperature	–55	150	°C

- (1) Stresses beyond those listed under *Absolute Maximum Ratings* may cause permanent damage to the device. These are stress ratings only, which do not imply functional operation of the device at these or any other conditions beyond those indicated under *Recommended Operating Conditions*. Exposure to absolute-maximum-rated conditions for extended periods may affect device reliability.

6.2 ESD Ratings

		VALUE	UNIT
V _(ESD)	Electrostatic discharge		V
	Human body model (HBM), per ANSI/ESDA/JEDEC JS-001, all pins ⁽¹⁾	±2000	
	Charged device model (CDM), per JEDEC specification JESD22-C101, all pins ⁽²⁾	±1500	

- (1) JEDEC document JEP155 states that 500-V HBM allows safe manufacturing with a standard ESD control process.
 (2) JEDEC document JEP157 states that 250-V CDM allows safe manufacturing with a standard ESD control process.

6.3 Recommended Operating Conditions

over operating free-air temperature range (unless otherwise noted)

		MIN	MAX	UNIT
V _{CC}	Supply voltage	4	28	V
V _H	Hall amplifier input voltage	1	V _{CC} – 0.5	V
T _A	Operating free-air temperature	–40	100	°C

6.4 Thermal Information

THERMAL METRIC ⁽¹⁾		TMP821	UNIT
		D (SOIC)	
		8 PINS	
R _{θJA}	Junction-to-ambient thermal resistance ⁽²⁾	97	°C/W
R _{θJC(top)}	Junction-to-case (top) thermal resistance	117.8	°C/W
R _{θJB}	Junction-to-board thermal resistance	71.5	°C/W
ψ _{JT}	Junction-to-top characterization parameter	58.3	°C/W
ψ _{JB}	Junction-to-board characterization parameter	23.6	°C/W
R _{θJC(bot)}	Junction-to-case (bottom) thermal resistance	57.8	°C/W

- (1) For more information about traditional and new thermal metrics, see the *Semiconductor and IC Package Thermal Metrics* application report, [SPRA953](#).
 (2) Package thermal impedance is calculated in accordance with JESD 51-7.

6.5 Electrical Characteristics

 $V_{CC} = 12\text{ V}$, $T_A = 25^\circ\text{C}$ (unless otherwise noted)

PARAMETER		TEST CONDITIONS	MIN	TYP	MAX	UNIT
V_{HYS}	Hall amplifier input voltage hysteresis		± 3		± 15	mV
V_{AL}	Lock alarm signal low-level output voltage	AL $I_{AL} = 5\text{ mA}$			0.5	V
I_{AL}	Lock alarm signal low-level output current	AL $V_{AL} = 2\text{ V}$	8			mA
I_{LDC}	Lock Detection capacitor charge current	LD $V_{LD} = 1.5\text{ V}$	2	3.45	5.25	μA
I_{LDD}	Lock Detection capacitor discharge current	LD $V_{LD} = 1.5\text{ V}$	0.35	0.8	1.45	μA
r_{CD}	Lock Detection capacitor charge and discharge current ratio	LD $r_{CD} = I_{LDC}/I_{LDD}$	3	4.5	8	
V_{LDCL}	Lock Detection capacitor clamp voltage	LD	2.2	2.6	3	V
V_{LDLCP}	Lock Detection capacitor comparator voltage	LD	0.4	0.6	0.8	V
V_{7H}	High-level output voltage	A1 $I_{OH} = -10\text{ mA}$	10	10.5		V
V_{8H}	High-level output voltage	A2 $I_{OH} = -10\text{ mA}$	10	10.5		V
I_{CC}	Supply current	Output off		3.2	5	mA

6.6 Typical Characteristics

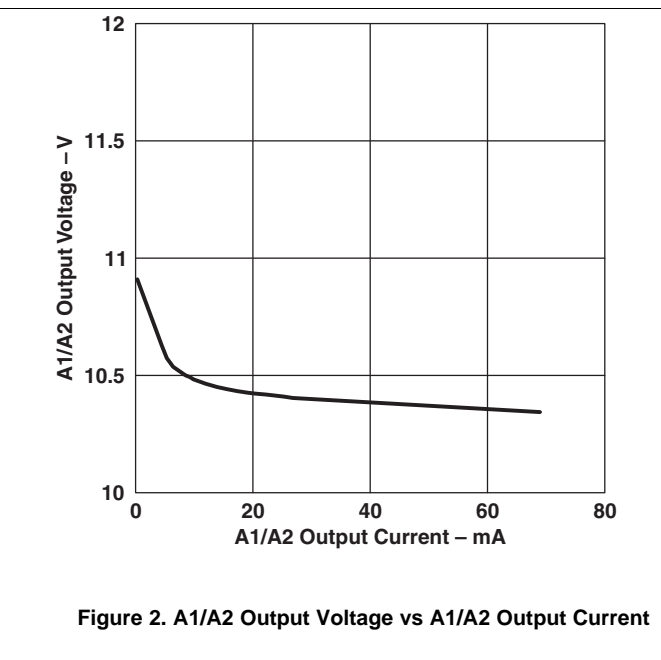
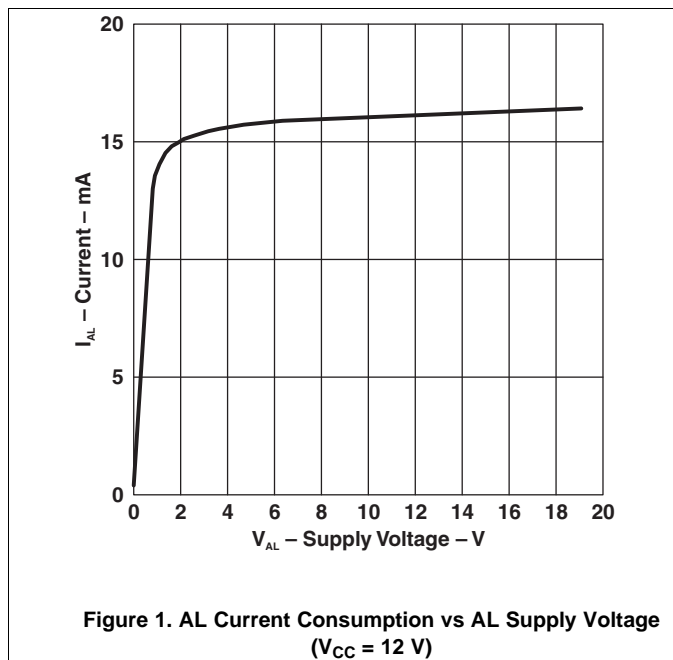

7 Detailed Description

7.1 Overview

The TMP821 device is a two phase half wave motor predriver suited for small fan applications. The two switches are controlled from the logic generated from differential hall sensors connected to the device. The drive logic operates in push-pull configuration. The TMP821 device is a very small package with minimum external components required, making the design very simple and easy. Speed information is available on a pin. The lock detect feature is also part of the features provided by the device whose timing is configured by connecting an external capacitor.

7.2 Functional Block Diagram

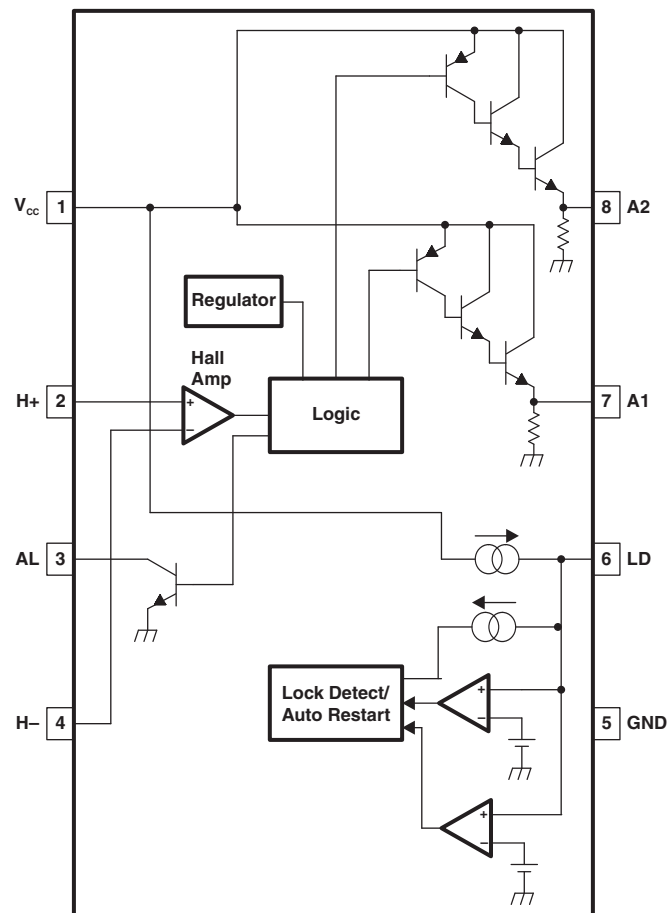

7.3 Feature Description

7.3.1 Lock Detection

The TMP821 device comes with the built-in lock detect feature. If it's not able to rotate the rotor for a specific amount of time, the Lock Detection disables the drive and retries after some time. The timings are dependant on the capacitor connected at LD Pin.

When a motor lock is detected, the TMP821 device automatically shuts down its output current. When the motor lock is removed, the TMP821 device automatically restarts. Motor lock is detected when the Hall signal stops switching, as shown in [Figure 3](#).

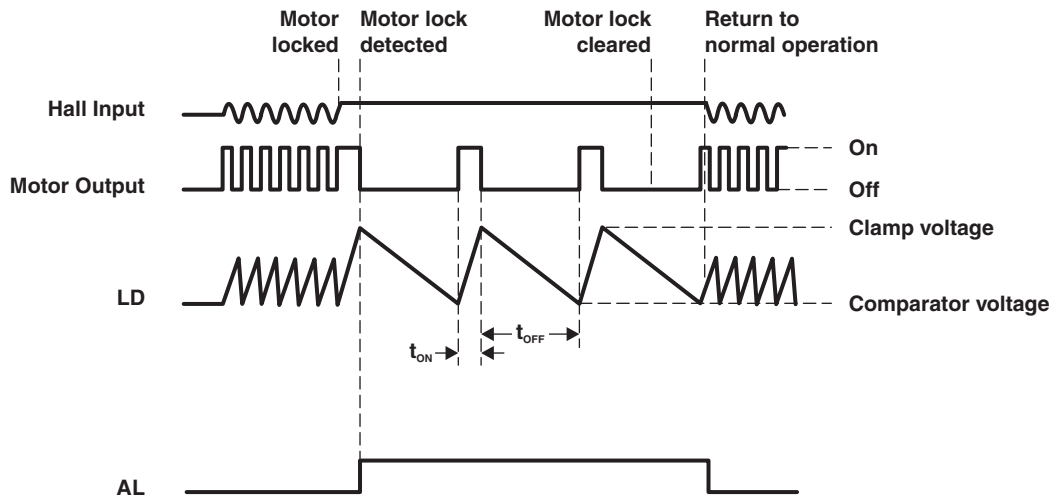

Figure 3. Motor Lock Diagram

t_{ON} and t_{OFF} are determined by the capacitor connected to LD:

$$t_{ON} = (C_{LD} \times (V_{LD_CLAMP} - V_{LD_COMP}) / I_{LD_CHARGE} \text{ (seconds)}) \quad (1)$$

$$t_{OFF} = (C_{LD} \times (V_{LD_CLAMP} - V_{LD_COMP}) / I_{LD_DISCHARGE} \text{ (seconds)})$$

where

- C_{LD} = capacitance of the external capacitor on LD
 - V_{LD_CLAMP} = LD clamp voltage
 - V_{LD_COMP} = LD comparator voltage
 - I_{LD_CHARGE} = LD charge current
 - $I_{LD_DISCHARGE}$ = LD discharge current
- (2)

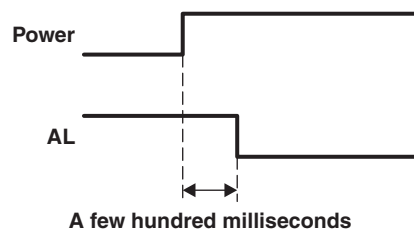

Figure 4. Power-on to AL Delay

7.3.2 Speed Sensing

The TMP821 device gives the speed information on the pin AL. This pin may remain high for few hundred milliseconds at the start-up. Once the motor attains some speed, the frequency can be observed at this pin.

Feature Description (continued)

NOTE

After power is supplied to the device, the Lock Detection pin (AL) may remain high for a few hundred milliseconds (see [Figure 4](#)).

7.4 Device Functional Modes**7.4.1 Lock Detection Pin**

When rotor is locked, the drive is enabled until the voltage at LD pin reaches a higher threshold. Once the voltage reaches a higher threshold, the drive is disabled until the LD capacitor discharges to a lower threshold.

7.4.2 Run

If the motor is unlocked and hall sensor inputs and drive signals are connected properly, the motor starts spinning.

8 Application and Implementation

NOTE

Information in the following applications sections is not part of the TI component specification, and TI does not warrant its accuracy or completeness. TI's customers are responsible for determining suitability of components for their purposes. Customers should validate and test their design implementation to confirm system functionality.

8.1 Application Information

The TMP821 device needs very few external components for the features described in [Feature Description](#). The device needs a 1- μ F or more capacitor connected at VCC. The Lock Detection capacitor decides the hiccup time.

8.2 Typical Application

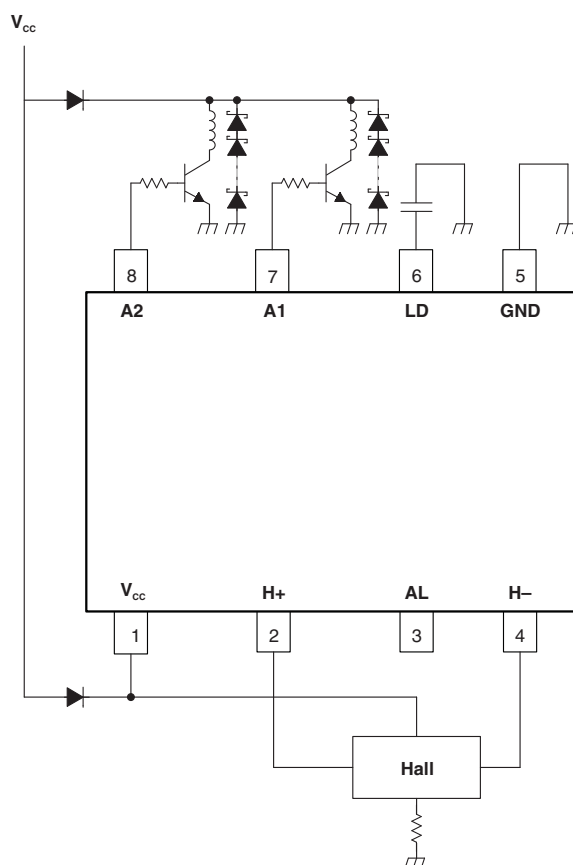

Figure 5. Typical Application Circuit

8.2.1 Design Requirements

For this design example, use the following parameters:

- Test setup input voltage: 12-V DC source
- VCC capacitor: 1 μ F or more
- H Bridge top side: P-channel FETs
- H Bridge bottom side: N-channel FETs

Typical Application (continued)

8.2.2 Detailed Design Procedure

Pins:

- Connect hall sensor differential inputs to IN+ and IN–.
- Connect LD to Lock Detection capacitor.
- Connect drive outputs to the gates of the H bridge switches.
- Pull up on FG.

Power Supply:

- Make sure the power supply is set with sufficient current limit at the decided motor voltage (12 V and 1 A are shown in [Application Curves](#)).

Build the circuit with recommended connections at the pins.

Test the motor circuit with hardware connected to it.

8.2.3 Application Curves

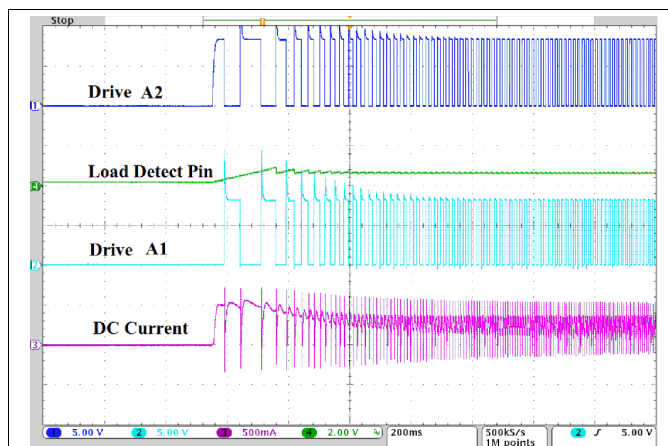

Figure 6. Start-up at 12 V (Soft Start)

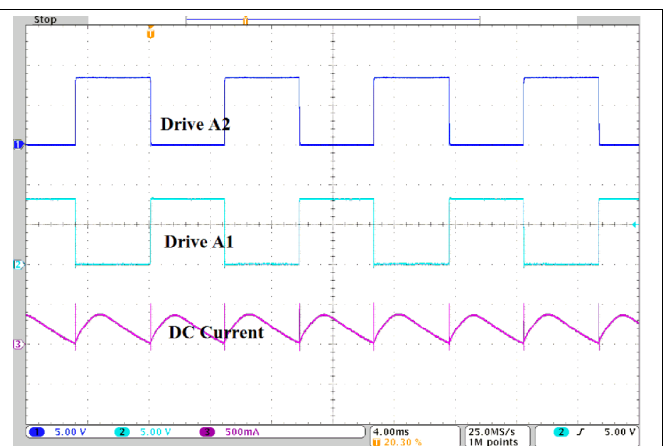

Figure 7. Motor Outputs and DC Current

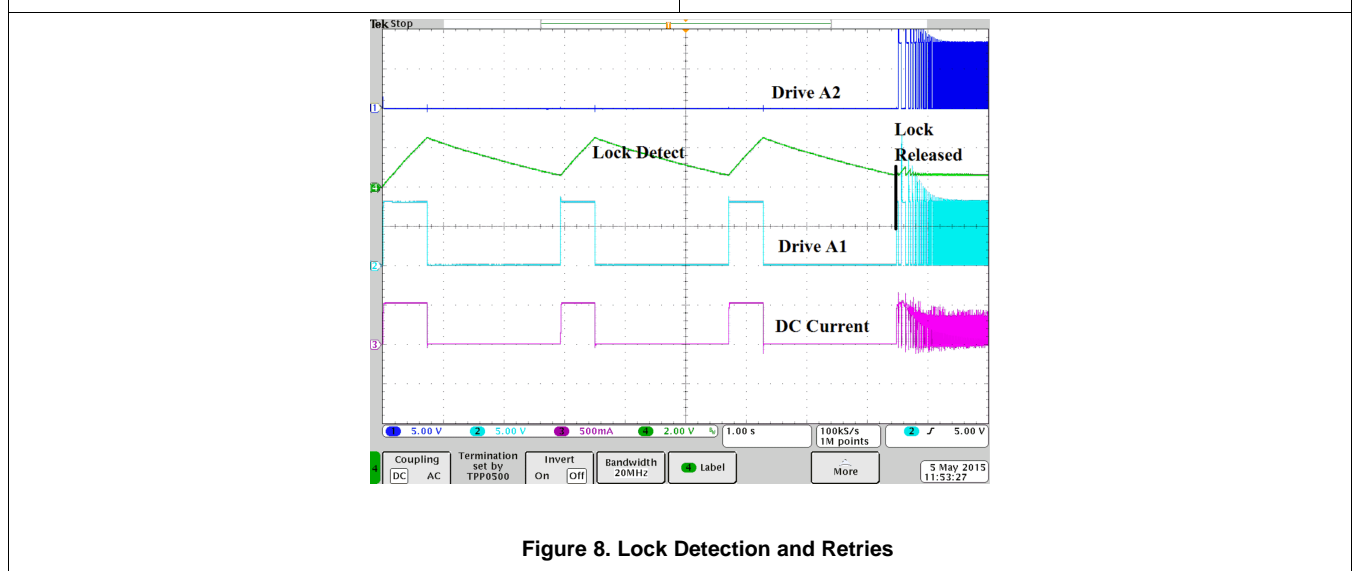

Figure 8. Lock Detection and Retries

9 Power Supply Recommendations

Connect a bulk capacitor of 1 μF or greater to VDD and GND. The maximum voltage applied must be less than 30 V.

10 Layout

10.1 Layout Guidelines

A bulk capacitor at the VDD and GND LD capacitor can be connected near the device as shown in [Figure 9](#).

10.2 Layout Example

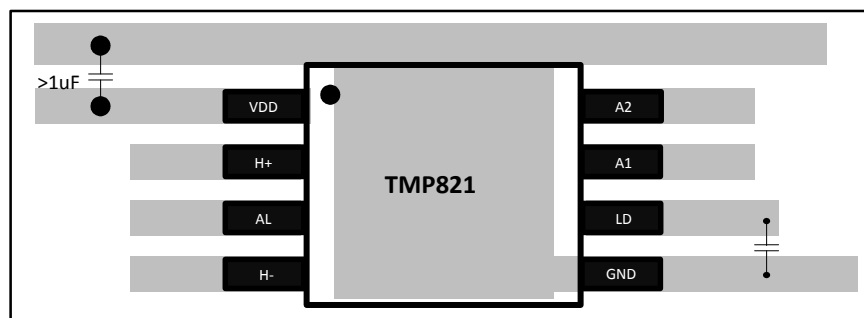

Figure 9. Recommended Layout Example

10.3 Power Dissipation

[Figure 10](#) shows allowable power dissipation versus ambient temperature.

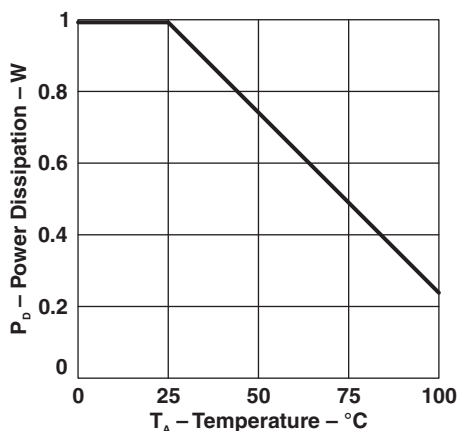

Figure 10. Power Dissipation

Use [Equation 3](#) to calculate total power consumption.

$$P_{\text{total}} = P_{C1} + P_{C2} + P_{C3}$$

where

- P_{C1} = circuit power dissipation
- $P_{C1} = V_{CC} \times I_{CC}$
- P_{C2} = output power dissipation
- $P_{C2} = (V_{CC} - V_{OH}) \times I_O$
- V_{OH} = A1 and A2 high-level voltage
- P_{C2} can be reduced by increasing the external output transistor's hFE rank to reduce the I_O consumption.

Power Dissipation (continued)

- P_{C3} = AL power dissipation
- $P_{C3} = V_{AL_LOW} \times I_{AL}$ (3)

11 Device and Documentation Support

11.1 Community Resource

The following links connect to TI community resources. Linked contents are provided "AS IS" by the respective contributors. They do not constitute TI specifications and do not necessarily reflect TI's views; see TI's [Terms of Use](#).

TI E2E™ Online Community *TI's Engineer-to-Engineer (E2E) Community*. Created to foster collaboration among engineers. At e2e.ti.com, you can ask questions, share knowledge, explore ideas and help solve problems with fellow engineers.

Design Support *TI's Design Support* Quickly find helpful E2E forums along with design support tools and contact information for technical support.

11.2 Trademarks

E2E is a trademark of Texas Instruments.
All other trademarks are the property of their respective owners.

11.3 Electrostatic Discharge Caution



These devices have limited built-in ESD protection. The leads should be shorted together or the device placed in conductive foam during storage or handling to prevent electrostatic damage to the MOS gates.

11.4 Glossary

[SLYZ022](#) — *TI Glossary*.

This glossary lists and explains terms, acronyms, and definitions.

12 Mechanical, Packaging, and Orderable Information

The following pages include mechanical, packaging, and orderable information. This information is the most current data available for the designated devices. This data is subject to change without notice and revision of this document. For browser-based versions of this data sheet, refer to the left-hand navigation.

PACKAGING INFORMATION

Orderable part number	Status (1)	Material type (2)	Package Pins	Package qty Carrier	RoHS (3)	Lead finish/ Ball material (4)	MSL rating/ Peak reflow (5)	Op temp (°C)	Part marking (6)
TMP821DR	Last Time Buy	Production	SOIC (D) 8	2500 LARGE T&R	Yes	NIPDAU	Level-1-260C-UNLIM	-40 to 100	TMP821
TMP821DR.A	Active	Production	SOIC (D) 8	2500 LARGE T&R	Yes	NIPDAU	Level-1-260C-UNLIM	-40 to 100	TMP821

(1) **Status:** For more details on status, see our [product life cycle](#).

(2) **Material type:** When designated, preproduction parts are prototypes/experimental devices, and are not yet approved or released for full production. Testing and final process, including without limitation quality assurance, reliability performance testing, and/or process qualification, may not yet be complete, and this item is subject to further changes or possible discontinuation. If available for ordering, purchases will be subject to an additional waiver at checkout, and are intended for early internal evaluation purposes only. These items are sold without warranties of any kind.

(3) **RoHS values:** Yes, No, RoHS Exempt. See the [TI RoHS Statement](#) for additional information and value definition.

(4) **Lead finish/Ball material:** Parts may have multiple material finish options. Finish options are separated by a vertical ruled line. Lead finish/Ball material values may wrap to two lines if the finish value exceeds the maximum column width.

(5) **MSL rating/Peak reflow:** The moisture sensitivity level ratings and peak solder (reflow) temperatures. In the event that a part has multiple moisture sensitivity ratings, only the lowest level per JEDEC standards is shown. Refer to the shipping label for the actual reflow temperature that will be used to mount the part to the printed circuit board.

(6) **Part marking:** There may be an additional marking, which relates to the logo, the lot trace code information, or the environmental category of the part.

Multiple part markings will be inside parentheses. Only one part marking contained in parentheses and separated by a "-" will appear on a part. If a line is indented then it is a continuation of the previous line and the two combined represent the entire part marking for that device.

Important Information and Disclaimer: The information provided on this page represents TI's knowledge and belief as of the date that it is provided. TI bases its knowledge and belief on information provided by third parties, and makes no representation or warranty as to the accuracy of such information. Efforts are underway to better integrate information from third parties. TI has taken and continues to take reasonable steps to provide representative and accurate information but may not have conducted destructive testing or chemical analysis on incoming materials and chemicals. TI and TI suppliers consider certain information to be proprietary, and thus CAS numbers and other limited information may not be available for release.

In no event shall TI's liability arising out of such information exceed the total purchase price of the TI part(s) at issue in this document sold by TI to Customer on an annual basis.

TAPE AND REEL INFORMATION

QUADRANT ASSIGNMENTS FOR PIN 1 ORIENTATION IN TAPE

*All dimensions are nominal

Device	Package Type	Package Drawing	Pins	SPQ	Reel Diameter (mm)	Reel Width W1 (mm)	A0 (mm)	B0 (mm)	K0 (mm)	P1 (mm)	W (mm)	Pin1 Quadrant
TMP821DR	SOIC	D	8	2500	330.0	12.4	6.4	5.2	2.1	8.0	12.0	Q1

TAPE AND REEL BOX DIMENSIONS

*All dimensions are nominal

Device	Package Type	Package Drawing	Pins	SPQ	Length (mm)	Width (mm)	Height (mm)
TMP821DR	SOIC	D	8	2500	353.0	353.0	32.0



D0008A

PACKAGE OUTLINE

SOIC - 1.75 mm max height

SMALL OUTLINE INTEGRATED CIRCUIT



4214825/C 02/2019

NOTES:

1. Linear dimensions are in inches [millimeters]. Dimensions in parenthesis are for reference only. Controlling dimensions are in inches. Dimensioning and tolerancing per ASME Y14.5M.
2. This drawing is subject to change without notice.
3. This dimension does not include mold flash, protrusions, or gate burrs. Mold flash, protrusions, or gate burrs shall not exceed $.006$ [0.15] per side.
4. This dimension does not include interlead flash.
5. Reference JEDEC registration MS-012, variation AA.

EXAMPLE BOARD LAYOUT

D0008A

SOIC - 1.75 mm max height

SMALL OUTLINE INTEGRATED CIRCUIT



LAND PATTERN EXAMPLE
EXPOSED METAL SHOWN
SCALE:8X



SOLDER MASK DETAILS

4214825/C 02/2019

NOTES: (continued)

- 6. Publication IPC-7351 may have alternate designs.
- 7. Solder mask tolerances between and around signal pads can vary based on board fabrication site.

EXAMPLE STENCIL DESIGN

D0008A

SOIC - 1.75 mm max height

SMALL OUTLINE INTEGRATED CIRCUIT



SOLDER PASTE EXAMPLE
BASED ON .005 INCH [0.125 MM] THICK STENCIL
SCALE:8X

4214825/C 02/2019

NOTES: (continued)

8. Laser cutting apertures with trapezoidal walls and rounded corners may offer better paste release. IPC-7525 may have alternate design recommendations.
9. Board assembly site may have different recommendations for stencil design.

IMPORTANT NOTICE AND DISCLAIMER

TI PROVIDES TECHNICAL AND RELIABILITY DATA (INCLUDING DATASHEETS), DESIGN RESOURCES (INCLUDING REFERENCE DESIGNS), APPLICATION OR OTHER DESIGN ADVICE, WEB TOOLS, SAFETY INFORMATION, AND OTHER RESOURCES "AS IS" AND WITH ALL FAULTS, AND DISCLAIMS ALL WARRANTIES, EXPRESS AND IMPLIED, INCLUDING WITHOUT LIMITATION ANY IMPLIED WARRANTIES OF MERCHANTABILITY, FITNESS FOR A PARTICULAR PURPOSE OR NON-INFRINGEMENT OF THIRD PARTY INTELLECTUAL PROPERTY RIGHTS.

These resources are intended for skilled developers designing with TI products. You are solely responsible for (1) selecting the appropriate TI products for your application, (2) designing, validating and testing your application, and (3) ensuring your application meets applicable standards, and any other safety, security, regulatory or other requirements.

These resources are subject to change without notice. TI grants you permission to use these resources only for development of an application that uses the TI products described in the resource. Other reproduction and display of these resources is prohibited. No license is granted to any other TI intellectual property right or to any third party intellectual property right. TI disclaims responsibility for, and you fully indemnify TI and its representatives against any claims, damages, costs, losses, and liabilities arising out of your use of these resources.

TI's products are provided subject to [TI's Terms of Sale](#), [TI's General Quality Guidelines](#), or other applicable terms available either on [ti.com](#) or provided in conjunction with such TI products. TI's provision of these resources does not expand or otherwise alter TI's applicable warranties or warranty disclaimers for TI products. Unless TI explicitly designates a product as custom or customer-specified, TI products are standard, catalog, general purpose devices.

TI objects to and rejects any additional or different terms you may propose.

Copyright © 2026, Texas Instruments Incorporated

Last updated 10/2025