

TMUX6236 36V, Low-RON, 2:1 (SPDT), 2-Channel Precision Switch With 1.8V Logic

1 Features

- Dual supply range: $\pm 4.5\text{V}$ to $\pm 18\text{V}$
- Single supply range: 4.5V to 36V
- Low on-resistance: 2Ω
- High current support: 330mA (maximum) (WQFN)
- -40°C to $+125^\circ\text{C}$ operating temperature
- [1.8V logic compatible](#)
- [Integrated pull-down resistor on logic pins](#)
- [Fail-safe logic](#)
- [Rail-to-rail operation](#)
- [Bidirectional operation](#)

2 Applications

- [Factory automation and industrial controls](#)
- Programmable logic controllers (PLC)
- Analog input modules
- ATE test equipment
- Battery monitoring systems
- [Ultrasound scanners](#)
- [Patient monitoring and diagnostics](#)
- Optical networking
- Optical test equipment
- Remote radio units
- [Wired networking](#)
- [Data acquisition systems](#)

3 Description

The TMUX6236 is a complementary metal-oxide semiconductor (CMOS) switch with two 2:1 switches. The device works well with dual supplies ($\pm 4.5\text{V}$ to $\pm 18\text{V}$), a single supply (4.5V to 36V), or asymmetric supplies (such as $V_{DD} = 12\text{V}$, $V_{SS} = -5\text{V}$). The TMUX6236 supports bidirectional analog and digital signals on the source (Sx) and drain (D) pins ranging from V_{SS} to V_{DD} .

All logic control inputs support logic levels from 1.8V to V_{DD} , allowing for both TTL and CMOS logic compatibility when operating in the valid supply voltage range. [Fail-Safe Logic](#) circuitry allows voltages on the control pins to be applied before the supply pin, protecting the device from potential damage.

Package Information

PART NUMBER	PACKAGE ⁽¹⁾	PACKAGE SIZE ⁽²⁾
TMUX6236	RUM (WQFN, 16)	4mm × 4mm
	PW (TSSOP, 16)	5mm × 6.4mm

(1) For more information, see [Section 11](#).

(2) The package size (length × width) is a nominal value and includes pins, where applicable.

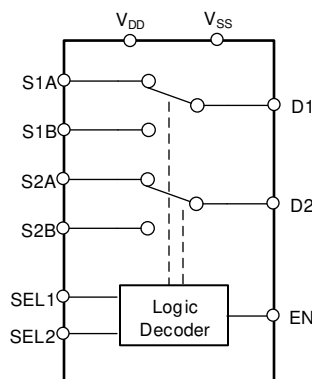

Block Diagram



Table of Contents

1 Features	1	6.8 Propagation Delay.....	22
2 Applications	1	6.9 Charge Injection.....	23
3 Description	1	6.10 Off Isolation.....	23
4 Pin Configuration and Functions	3	6.11 Crosstalk.....	24
5 Specifications	4	6.12 Bandwidth.....	24
5.1 Absolute Maximum Ratings.....	4	6.13 THD + Noise.....	25
5.2 ESD Ratings.....	4	6.14 Power Supply Rejection Ratio (PSRR).....	25
5.3 Thermal Information.....	4	7 Detailed Description	26
5.4 Recommended Operating Conditions.....	5	7.1 Functional Block Diagram.....	26
5.5 Source or Drain Continuous Current.....	5	7.2 Feature Description.....	26
5.6 ±15V Dual Supply: Electrical Characteristics	6	7.3 Device Functional Modes.....	28
5.7 ±15V Dual Supply: Switching Characteristics	7	7.4 Truth Tables.....	28
5.8 36V Single Supply: Electrical Characteristics	8	8 Application and Implementation	29
5.9 36V Single Supply: Switching Characteristics	9	8.1 Application Information.....	29
5.10 12V Single Supply: Electrical Characteristics	10	8.2 Typical Application.....	29
5.11 12V Single Supply: Switching Characteristics	11	8.3 Power Supply Recommendations.....	30
5.12 ±5V Dual Supply: Electrical Characteristics	12	8.4 Layout.....	31
5.13 ±5V Dual Supply: Switching Characteristics	13	9 Device and Documentation Support	33
5.14 Typical Characteristics.....	14	9.1 Documentation Support.....	33
6 Parameter Measurement Information	19	9.2 Receiving Notification of Documentation Updates....	33
6.1 On-Resistance.....	19	9.3 Support Resources.....	33
6.2 Off-Leakage Current.....	19	9.4 Trademarks.....	33
6.3 On-Leakage Current.....	20	9.5 Glossary.....	33
6.4 Transition Time.....	20	9.6 Electrostatic Discharge Caution.....	33
6.5 $t_{ON(EN)}$ and $t_{OFF(EN)}$	21	10 Revision History	33
6.6 Break-Before-Make.....	21	11 Mechanical, Packaging, and Orderable Information	34
6.7 $t_{ON(VDD)}$ Time.....	22		

4 Pin Configuration and Functions

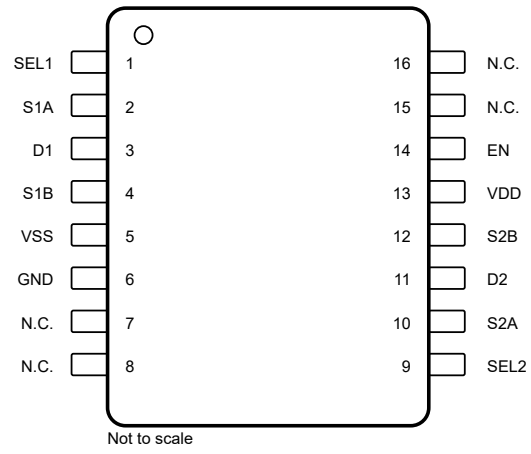
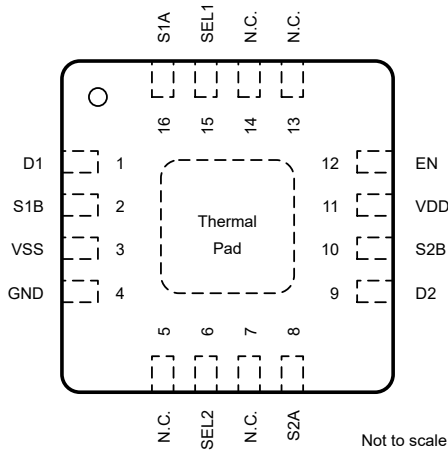

Figure 4-1. RUM Package, 16-Pin WQFN (Top View) Figure 4-2. PW Package, 16-Pin TSSOP (Top View)

Table 4-1. Pin Functions

NAME	PIN		TYPE ⁽¹⁾	DESCRIPTION
	TSSOP	WQFN		
D1	3	1	I/O	Drain pin. Can be an input or output.
D2	11	9	I/O	Drain pin. Can be an input or output.
EN	14	12	I	Active high logic enable, has internal pull-up resistor. When this pin is low, all switches are turned off. When this pin is high, the SEL logic input determine which switch is turned on.
GND	6	4	P	Ground (0V) reference
NC	7, 8, 15, 16	5, 7, 13, 14	—	No internal connection. Can be shorted to GND or left floating.
S1A	2	16	I/O	Source pin 1A. Can be an input or output.
S1B	4	2	I/O	Source pin 1B. Can be an input or output.
S2A	10	8	I/O	Source pin 2A. Can be an input or output.
S2B	12	10	I/O	Source pin 2B. Can be an input or output.
SEL1	1	15	I	Logic control input, has internal pull-down resistor. Table 7-1 lists how to control the switch connection.
SEL2	9	6	I	Logic control input, has internal pull-down resistor. Table 7-1 lists how to control the switch connection.
V _{DD}	13	11	P	Positive power supply. This pin is the most positive power-supply potential. For reliable operation, connect a decoupling capacitor ranging from 0.1µF to 10µF between V _{DD} and GND.
V _{SS}	5	3	P	Negative power supply. This pin is the most negative power-supply potential. In single-supply applications, this pin can be connected to ground. For reliable operation, connect a decoupling capacitor ranging from 0.1µF to 10µF between V _{SS} and GND.
Thermal Pad			—	The thermal pad is not connected internally. There is no requirement to electrically connect this pad. If connected, however, it is recommended that the pad be left floating or tied to GND.

(1) I = input, O = output, P = power

5 Specifications

5.1 Absolute Maximum Ratings

over operating free-air temperature range (unless otherwise noted)⁽¹⁾ ⁽²⁾

		MIN	MAX	UNIT
$V_{DD} - V_{SS}$	Supply voltage		38	V
V_{DD}		-0.5	38	V
V_{SS}		-38	0.5	V
V_{SEL} or V_{EN}	Logic control input pin voltage (SELx)	-0.5	38	V
I_{SEL} or I_{EN}	Logic control input pin current (SELx)	-30	30	mA
V_S or V_D	Source or drain voltage (Sx, Dx)	$V_{SS}-0.5$	$V_{DD}+0.5$	V
I_{IK}	Diode clamp current ⁽³⁾	-30	30	mA
I_S or I_D (CONT)	Source or drain continuous current (Sx, Dx)		$I_{DC} + 10\%$ ⁽⁴⁾	mA
T_A	Ambient temperature	-55	150	°C
T_{stg}	Storage temperature	-65	150	°C
T_J	Junction temperature		150	°C
P_{tot}	Total power dissipation (TSSOP) ⁽⁵⁾		720	mW
P_{tot}	Total power dissipation (QFN) ⁽⁶⁾		1650	mW

- (1) Operation outside the *Absolute Maximum Ratings* may cause permanent device damage. *Absolute Maximum Ratings* do not imply functional operation of the device at these or any other conditions beyond those listed under *Recommended Operating Conditions*. If used outside the *Recommended Operating Conditions* but within the *Absolute Maximum Ratings*, the device may not be fully functional, and this may affect device reliability, functionality, performance, and shorten the device lifetime.
- (2) All voltages are with respect to ground, unless otherwise specified.
- (3) Pins are diode-clamped to the power-supply rails. Over voltage signals must be voltage and current limited to maximum ratings.
- (4) Refer to *Source or Drain Continuous Current* table for I_{DC} specifications.
- (5) For QFN package: P_{tot} derates linearly above $T_A = 70^\circ\text{C}$ by $10.3\text{mW}/^\circ\text{C}$.
- (6) For QFN package: P_{tot} derates linearly above $T_A = 70^\circ\text{C}$ by $24.2\text{mW}/^\circ\text{C}$.

5.2 ESD Ratings

			VALUE	UNIT
$V_{(ESD)}$	Electrostatic discharge	Human body model (HBM), per ANSI/ESDA/ JEDEC JS-001, all pins ⁽¹⁾	±1000	V
		Charged device model (CDM), per ANSI/ESDA/ JEDEC JS-002, all pins ⁽²⁾	±500	

- (1) JEDEC document JEP155 states that 500-V HBM allows safe manufacturing with a standard ESD control process.
- (2) JEDEC document JEP157 states that 250-V CDM allows safe manufacturing with a standard ESD control process.

5.3 Thermal Information

THERMAL METRIC ⁽¹⁾		TMUX6236		UNIT
		RUM (WQFN)	PW (TSSOP)	
		16 PINS	16 PINS	
$R_{\theta JA}$	Junction-to-ambient thermal resistance	41.5	97.1	°C/W
$R_{\theta JC(top)}$	Junction-to-case (top) thermal resistance	25.1	25.6	°C/W
$R_{\theta JB}$	Junction-to-board thermal resistance	16.5	44.1	°C/W
Ψ_{JT}	Junction-to-top characterization parameter	0.3	1.1	°C/W
Ψ_{JB}	Junction-to-board characterization parameter	16.4	43.4	°C/W
$R_{\theta JC(bot)}$	Junction-to-case (bottom) thermal resistance	2.9	N/A	°C/W

- (1) For more information about traditional and new thermal metrics, see the [Semiconductor and IC Package Thermal Metrics](#) application report.

5.4 Recommended Operating Conditions

over operating free-air temperature range (unless otherwise noted)

		MIN	NOM	MAX	UNIT
$V_{DD} - V_{SS}$ ⁽¹⁾	Power supply voltage differential	4.5		36	V
V_{DD}	Positive power supply voltage	4.5		36	V
V_S or V_D	Signal path input/output voltage (source or drain pin) (Sx, D)	V_{SS}		V_{DD}	V
V_{SEL} or V_{EN}	Address or enable pin voltage	0		36	V
I_S or I_D (CONT)	Source or drain continuous current (Sx, D)			I_{DC} ⁽²⁾	mA
T_A	Ambient temperature	-40		125	°C

(1) V_{DD} and V_{SS} can be any value as long as $4.5V \leq (V_{DD} - V_{SS}) \leq 36V$, and the minimum V_{DD} is met.

(2) Refer to *Source or Drain Continuous Current* table for I_{DC} specifications.

5.5 Source or Drain Continuous Current

at supply voltage of $V_{DD} \pm 10\%$, $V_{SS} \pm 10\%$ (unless otherwise noted)

CONTINUOUS CURRENT PER CHANNEL (I_{DC}) ⁽²⁾		$T_A = 25^\circ\text{C}$	$T_A = 85^\circ\text{C}$	$T_A = 125^\circ\text{C}$	UNIT
PACKAGE	TEST CONDITIONS				
PW (TSSOP)	+36V Single Supply ⁽¹⁾	455	300	165	mA
	$\pm 15V$ Dual Supply	455	300	165	mA
	+12V Single Supply	355	240	145	mA
	$\pm 5V$ Dual Supply	335	225	140	mA
	+5V Single Supply	240	170	110	mA
RUM (WQFN)	+36V Single Supply ⁽¹⁾	650	400	190	mA
	$\pm 15V$ Dual Supply	640	380	180	mA
	+12V Single Supply	500	310	170	mA
	$\pm 5V$ Dual Supply	460	275	160	mA
	+5V Single Supply	330	210	120	mA

(1) Specified for nominal supply voltage only.

(2) Refer to Total power dissipation (P_{tot}) limits in *Absolute Maximum Ratings* table that must be followed with max continuous current specification.

5.6 ±15V Dual Supply: Electrical Characteristics

$V_{DD} = +15V \pm 10\%$, $V_{SS} = -15V \pm 10\%$, GND = 0V (unless otherwise noted)

Typical at $V_{DD} = +15V$, $V_{SS} = -15V$, $T_A = 25^\circ C$ (unless otherwise noted)

PARAMETER		TEST CONDITIONS	T_A	MIN	TYP	MAX	UNIT	
ANALOG SWITCH								
R_{ON}	On-resistance	$V_S = -10V$ to $+10V$ $I_D = -10mA$ Refer to On-Resistance	25°C		2	2.7	Ω	
			-40°C to +85°C			3.4	Ω	
			-40°C to +125°C			4	Ω	
ΔR_{ON}	On-resistance mismatch between channels	$V_S = -10V$ to $+10V$ $I_D = -10mA$ Refer to On-Resistance	25°C		0.1	0.18	Ω	
			-40°C to +85°C			0.19	Ω	
			-40°C to +125°C			0.21	Ω	
$R_{ON\ FLAT}$	On-resistance flatness	$V_S = -10V$ to $+10V$ $I_S = -10mA$ Refer to On-Resistance	25°C		0.2	0.46	Ω	
			-40°C to +85°C			0.65	Ω	
			-40°C to +125°C			0.7	Ω	
$R_{ON\ DRIFT}$	On-resistance drift	$V_S = 0V$, $I_S = -10mA$ Refer to On-Resistance	-40°C to +125°C		0.008		$\Omega/^\circ C$	
$I_{S(OFF)}$	Source off leakage current ⁽¹⁾	$V_{DD} = 16.5V$, $V_{SS} = -16.5V$ Switch state is off $V_S = +10V / -10V$ $V_D = -10V / +10V$ Refer to Off-Leakage Current	25°C	-0.35	0.05	0.35	nA	
			-40°C to +85°C		-3		3	nA
			-40°C to +125°C		-20		20	nA
$I_{D(OFF)}$	Drain off leakage current ⁽¹⁾	$V_{DD} = 16.5V$, $V_{SS} = -16.5V$ Switch state is off $V_S = +10V / -10V$ $V_D = -10V / +10V$ Refer to Off-Leakage Current	25°C	-0.6	0.1	0.6	nA	
			-40°C to +85°C		-7		7	nA
			-40°C to +125°C		-45		45	nA
$I_{S(ON)}$ $I_{D(ON)}$	Channel on leakage current ⁽²⁾	$V_{DD} = 16.5V$, $V_{SS} = -16.5V$ Switch state is on $V_S = V_D = \pm 10V$ Refer to On-Leakage Current	25°C	-0.5	0.05	0.5	nA	
			-40°C to +85°C		-3.5		3.5	nA
			-40°C to +125°C		-25		25	nA
LOGIC INPUTS (SEL / EN pins)								
V_{IH}	Logic voltage high		-40°C to +125°C	1.3		36	V	
V_{IL}	Logic voltage low		-40°C to +125°C	0		0.8	V	
I_{IH}	Input leakage current		-40°C to +125°C		0.4	2	μA	
I_{IL}	Input leakage current		-40°C to +125°C	-1.5	-0.005		μA	
C_{IN}	Logic input capacitance		-40°C to +125°C		3.5		pF	
POWER SUPPLY								
I_{DD}	V_{DD} supply current	$V_{DD} = 16.5V$, $V_{SS} = -16.5V$ Logic inputs = 0V, 5V, or V_{DD}	25°C		45	60	μA	
			-40°C to +85°C			70	μA	
			-40°C to +125°C			85	μA	
I_{SS}	V_{SS} supply current	$V_{DD} = 16.5V$, $V_{SS} = -16.5V$ Logic inputs = 0V, 5V, or V_{DD}	25°C		7	24	μA	
			-40°C to +85°C			30	μA	
			-40°C to +125°C			38	μA	

(1) When V_S is positive, V_D is negative, or when V_S is negative, V_D is positive.

(2) When V_S is at a voltage potential, V_D is floating, or when V_D is at a voltage potential, V_S is floating.

5.7 ±15V Dual Supply: Switching Characteristics

$V_{DD} = +15V \pm 10\%$, $V_{SS} = -15V \pm 10\%$, $GND = 0V$ (unless otherwise noted)

Typical at $V_{DD} = +15V$, $V_{SS} = -15V$, $T_A = 25^\circ C$ (unless otherwise noted)

PARAMETER		TEST CONDITIONS	T_A	MIN	TYP	MAX	UNIT
t_{TRAN}	Transition time from control input	$V_S = 10V$ $R_L = 300\Omega$, $C_L = 35pF$ Refer to Transition Time	25°C		110	130	ns
			-40°C to +85°C			160	ns
			-40°C to +125°C			180	ns
t_{ON}	Turn-on time from control input	$V_S = 10V$ $R_L = 300\Omega$, $C_L = 35pF$ Refer to Turn-on and Turn-off Time	25°C		95	120	ns
			-40°C to +85°C			135	ns
			-40°C to +125°C			145	ns
t_{OFF}	Turn-off time from control input	$V_S = 10V$ $R_L = 300\Omega$, $C_L = 35pF$ Refer to Turn-on and Turn-off Time	25°C		125	160	ns
			-40°C to +85°C			175	ns
			-40°C to +125°C			190	ns
t_{BBM}	Break-before-make time delay	$V_S = 10V$, $R_L = 300\Omega$, $C_L = 35pF$ Refer to Break-before-make Time	25°C		27		ns
			-40°C to +85°C		5		ns
			-40°C to +125°C		5		ns
$t_{ON(VDD)}$	Device turn on time (V_{DD} to output)	V_{DD} rise time = 1 μs $R_L = 300\Omega$, $C_L = 35pF$ Refer to Turn-on (VDD) Time	25°C		0.17		ms
			-40°C to +85°C			0.18	ms
			-40°C to +125°C			0.18	ms
t_{PD}	Propagation delay	$R_L = 50\Omega$, $C_L = 5pF$ Refer to Propagation Delay	25°C		720		ps
Q_{INJ}	Charge injection	$V_S = 0V$, $C_L = 100pF$ Refer to Charge Injection	25°C		30		pC
O_{ISO}	Off-isolation	$R_L = 50\Omega$, $C_L = 5pF$ $V_S = 0V$, $f = 100kHz$ Refer to Off Isolation	25°C		-70		dB
O_{ISO}	Off-isolation	$R_L = 50\Omega$, $C_L = 5pF$ $V_S = 0V$, $f = 1MHz$ Refer to Off Isolation	25°C		-50		dB
X_{TALK}	Crosstalk	$R_L = 50\Omega$, $C_L = 5pF$ $V_S = 0V$, $f = 100kHz$ Refer to Crosstalk	25°C		-107		dB
X_{TALK}	Crosstalk	$R_L = 50\Omega$, $C_L = 5pF$ $V_S = 0V$, $f = 1MHz$ Refer to Crosstalk	25°C		-93		dB
BW	-3dB Bandwidth	$R_L = 50\Omega$, $C_L = 5pF$ $V_S = 0V$ Refer to Bandwidth	25°C		40		MHz
I_L	Insertion loss	$R_L = 50\Omega$, $C_L = 5pF$ $V_S = 0V$, $f = 1MHz$	25°C		-0.15		dB
ACPSRR	AC Power Supply Rejection Ratio	$V_{PP} = 0.62V$ on V_{DD} and V_{SS} $R_L = 50\Omega$, $C_L = 5pF$, $f = 1MHz$ Refer to ACPSRR	25°C		-68		dB
THD+N	Total Harmonic Distortion + Noise	$V_{PP} = 15V$, $V_{BIAS} = 0V$ $R_L = 10k\Omega$, $C_L = 5pF$, $f = 20Hz$ to 20kHz Refer to THD + Noise	25°C		0.0006		%
$C_{S(OFF)}$	Source off capacitance	$V_S = 0V$, $f = 1MHz$	25°C		45		pF
$C_{D(OFF)}$	Drain off capacitance	$V_S = 0V$, $f = 1MHz$	25°C		55		pF
$C_{S(ON)}$, $C_{D(ON)}$	On capacitance	$V_S = 0V$, $f = 1MHz$	25°C		165		pF

5.8 36V Single Supply: Electrical Characteristics

$V_{DD} = +36V \pm 10\%$, $V_{SS} = 0V$, $GND = 0V$ (unless otherwise noted)

Typical at $V_{DD} = +36V$, $V_{SS} = 0V$, $T_A = 25^\circ C$ (unless otherwise noted)

PARAMETER		TEST CONDITIONS	T_A	MIN	TYP	MAX	UNIT	
ANALOG SWITCH								
R_{ON}	On-resistance	$V_S = 0V$ to $30V$ $I_D = -10mA$ Refer to On-Resistance	$25^\circ C$	2.1	3.1		Ω	
			$-40^\circ C$ to $+85^\circ C$			3.5	Ω	
			$-40^\circ C$ to $+125^\circ C$			4.4	Ω	
ΔR_{ON}	On-resistance mismatch between channels	$V_S = 0V$ to $30V$ $I_D = -10mA$ Refer to On-Resistance	$25^\circ C$	0.1	0.18		Ω	
			$-40^\circ C$ to $+85^\circ C$			0.19	Ω	
			$-40^\circ C$ to $+125^\circ C$			0.21	Ω	
$R_{ON\ FLAT}$	On-resistance flatness	$V_S = 0V$ to $30V$ $I_D = -10mA$ Refer to On-Resistance	$25^\circ C$	0.7	1.25		Ω	
			$-40^\circ C$ to $+85^\circ C$			1.3	Ω	
			$-40^\circ C$ to $+125^\circ C$			1.35	Ω	
$R_{ON\ DRIFT}$	On-resistance drift	$V_S = 18V$, $I_S = -10mA$ Refer to On-Resistance	$-40^\circ C$ to $+125^\circ C$	0.008			$\Omega/^\circ C$	
$I_{S(OFF)}$	Source off leakage current ⁽¹⁾	$V_{DD} = 39.6V$, $V_{SS} = 0V$ Switch state is off $V_S = 30V / 1V$ $V_D = 1V / 30V$ Refer to Off-Leakage Current	$25^\circ C$	-0.25	0.05	0.25	nA	
			$-40^\circ C$ to $+85^\circ C$		-5		5	nA
			$-40^\circ C$ to $+125^\circ C$		-39		39	nA
$I_{D(OFF)}$	Drain off leakage current ⁽¹⁾	$V_{DD} = 39.6V$, $V_{SS} = 0V$ Switch state is off $V_S = 30V / 1V$ $V_D = 1V / 30V$ Refer to Off-Leakage Current	$25^\circ C$	-0.6	0.12	0.6	nA	
			$-40^\circ C$ to $+85^\circ C$		-12		12	nA
			$-40^\circ C$ to $+125^\circ C$		-80		80	nA
$I_{S(ON)}$ $I_{D(ON)}$	Channel on leakage current ⁽²⁾	$V_{DD} = 39.6V$, $V_{SS} = 0V$ Switch state is on $V_S = V_D = 30V$ or $1V$ Refer to On-Leakage Current	$25^\circ C$	-0.25	0.05	0.25	nA	
			$-40^\circ C$ to $+85^\circ C$		-5		5	nA
			$-40^\circ C$ to $+125^\circ C$		-39		39	nA
LOGIC INPUTS (SEL / EN pins)								
V_{IH}	Logic voltage high		$-40^\circ C$ to $+125^\circ C$	1.3		44	V	
V_{IL}	Logic voltage low		$-40^\circ C$ to $+125^\circ C$	0		0.8	V	
I_{IH}	Input leakage current		$-40^\circ C$ to $+125^\circ C$		1	2.75	μA	
I_{IL}	Input leakage current		$-40^\circ C$ to $+125^\circ C$	-1.25	-0.005		μA	
C_{IN}	Logic input capacitance		$-40^\circ C$ to $+125^\circ C$		3.5		pF	
POWER SUPPLY								
I_{DD}	V_{DD} supply current	$V_{DD} = 39.6V$, $V_{SS} = 0V$ Logic inputs = $0V$, $5V$, or V_{DD}	$25^\circ C$	50	75		μA	
			$-40^\circ C$ to $+85^\circ C$			85	μA	
			$-40^\circ C$ to $+125^\circ C$			100	μA	

(1) When V_S is positive, V_D is negative, or when V_S is negative, V_D is positive.

(2) When V_S is at a voltage potential, V_D is floating, or when V_D is at a voltage potential, V_S is floating.

5.9 36V Single Supply: Switching Characteristics

$V_{DD} = +36V \pm 10\%$, $V_{SS} = 0V$, $GND = 0V$ (unless otherwise noted)
Typical at $V_{DD} = +36V$, $V_{SS} = 0V$, $T_A = 25^\circ C$ (unless otherwise noted)

PARAMETER		TEST CONDITIONS	T_A	MIN	TYP	MAX	UNIT
t_{TRAN}	Transition time from control input	$V_S = 18V$ $R_L = 300\Omega$, $C_L = 35pF$ Refer to Transition Time	25°C		85	135	ns
			-40°C to +85°C			150	ns
			-40°C to +125°C			170	ns
t_{ON}	Turn-on time from control input	$V_S = 18V$ $R_L = 300\Omega$, $C_L = 35pF$ Refer to Turn-on and Turn-off Time	25°C		90	130	ns
			-40°C to +85°C			150	ns
			-40°C to +125°C			170	ns
t_{OFF}	Turn-off time from control input	$V_S = 18V$ $R_L = 300\Omega$, $C_L = 35pF$ Refer to Turn-on and Turn-off Time	25°C		120	165	ns
			-40°C to +85°C			180	ns
			-40°C to +125°C			195	ns
t_{BBM}	Break-before-make time delay	$V_S = 18V$, $R_L = 300\Omega$, $C_L = 35pF$ Refer to Break-before-make Time	25°C		30		ns
			-40°C to +85°C		8		ns
			-40°C to +125°C		8		ns
$t_{ON(VDD)}$	Device turn on time (V_{DD} to output)	V_{DD} rise time = 1 μ s $R_L = 300\Omega$, $C_L = 35pF$ Refer to Turn-on (VDD) Time	25°C		0.16		ms
			-40°C to +85°C			0.17	ms
			-40°C to +125°C			0.17	ms
t_{PD}	Propagation delay	$R_L = 50\Omega$, $C_L = 5pF$ Refer to Propagation Delay	25°C		900		ps
Q_{INJ}	Charge injection	$V_S = 18V$, $C_L = 100pF$ Refer to Charge Injection	25°C		78		pC
O_{ISO}	Off-isolation	$R_L = 50\Omega$, $C_L = 5pF$ $V_S = 6V$, $f = 100kHz$ Refer to Off Isolation	25°C		-70		dB
O_{ISO}	Off-isolation	$R_L = 50\Omega$, $C_L = 5pF$ $V_S = 6V$, $f = 1MHz$ Refer to Off Isolation	25°C		-50		dB
X_{TALK}	Crosstalk	$R_L = 50\Omega$, $C_L = 5pF$ $V_S = 6V$, $f = 100kHz$ Refer to Crosstalk	25°C		-112		dB
X_{TALK}	Crosstalk	$R_L = 50\Omega$, $C_L = 5pF$ $V_S = 6V$, $f = 1MHz$ Refer to Crosstalk	25°C		-93		dB
BW	-3dB Bandwidth	$R_L = 50\Omega$, $C_L = 5pF$ $V_S = 6V$ Refer to Bandwidth	25°C		35		MHz
I_L	Insertion loss	$R_L = 50\Omega$, $C_L = 5pF$ $V_S = 6V$, $f = 1MHz$	25°C		-0.16		dB
ACPSRR	AC Power Supply Rejection Ratio	$V_{PP} = 0.62V$ on V_{DD} and V_{SS} $R_L = 50\Omega$, $C_L = 5pF$, $f = 1MHz$ Refer to ACPSRR	25°C		-65		dB
THD+N	Total Harmonic Distortion + Noise	$V_{PP} = 18V$, $V_{BIAS} = 6V$ $R_L = 10k\Omega$, $C_L = 5pF$, $f = 20Hz$ to 20kHz Refer to THD + Noise	25°C		0.0006		%
$C_{S(OFF)}$	Source off capacitance	$V_S = 6V$, $f = 1MHz$	25°C		45		pF
$C_{D(OFF)}$	Drain off capacitance	$V_S = 6V$, $f = 1MHz$	25°C		60		pF
$C_{S(ON)}$, $C_{D(ON)}$	On capacitance	$V_S = 6V$, $f = 1MHz$	25°C		165		pF

5.10 12V Single Supply: Electrical Characteristics

$V_{DD} = +12V \pm 10\%$, $V_{SS} = 0V$, $GND = 0V$ (unless otherwise noted)

Typical at $V_{DD} = +12V$, $V_{SS} = 0V$, $T_A = 25^\circ C$ (unless otherwise noted)

PARAMETER		TEST CONDITIONS	T_A	MIN	TYP	MAX	UNIT	
ANALOG SWITCH								
R_{ON}	On-resistance	$V_S = 0V$ to $10V$ $I_D = -10mA$ Refer to On-Resistance	$25^\circ C$	2.8	5.4		Ω	
			$-40^\circ C$ to $+85^\circ C$			6.8	Ω	
			$-40^\circ C$ to $+125^\circ C$			7.4	Ω	
ΔR_{ON}	On-resistance mismatch between channels	$V_S = 0V$ to $10V$ $I_D = -10mA$ Refer to On-Resistance	$25^\circ C$	0.13	0.21		Ω	
			$-40^\circ C$ to $+85^\circ C$			0.23	Ω	
			$-40^\circ C$ to $+125^\circ C$			0.25	Ω	
$R_{ON\ FLAT}$	On-resistance flatness	$V_S = 0V$ to $10V$ $I_D = -10mA$ Refer to On-Resistance	$25^\circ C$	0.8	1.7		Ω	
			$-40^\circ C$ to $+85^\circ C$			1.9	Ω	
			$-40^\circ C$ to $+125^\circ C$			2	Ω	
$R_{ON\ DRIFT}$	On-resistance drift	$V_S = 0V$, $I_S = -10mA$ Refer to On-Resistance	$-40^\circ C$ to $+125^\circ C$	0.015			$\Omega/^\circ C$	
$I_{S(OFF)}$	Source off leakage current ⁽¹⁾	$V_{DD} = 13.2V$, $V_{SS} = 0V$ Switch state is off $V_S = 10V / 1V$ $V_D = 1V / 10V$ Refer to Off-Leakage Current	$25^\circ C$	-0.25	0.01	0.25	nA	
			$-40^\circ C$ to $+85^\circ C$		-2		2	nA
			$-40^\circ C$ to $+125^\circ C$		-16		16	nA
$I_{D(OFF)}$	Drain off leakage current ⁽¹⁾	$V_{DD} = 13.2V$, $V_{SS} = 0V$ Switch state is off $V_S = 10V / 1V$ $V_D = 1V / 10V$ Refer to Off-Leakage Current	$25^\circ C$	-0.6	0.12	0.6	nA	
			$-40^\circ C$ to $+85^\circ C$		-5		5	nA
			$-40^\circ C$ to $+125^\circ C$		-34		34	nA
$I_{S(ON)}$ $I_{D(ON)}$	Channel on leakage current ⁽²⁾	$V_{DD} = 13.2V$, $V_{SS} = 0V$ Switch state is on $V_S = V_D = 10V$ or $1V$ Refer to On-Leakage Current	$25^\circ C$	-0.35	0.01	0.35	nA	
			$-40^\circ C$ to $+85^\circ C$		-2		2	nA
			$-40^\circ C$ to $+125^\circ C$		-16		16	nA
LOGIC INPUTS (SEL / EN pins)								
V_{IH}	Logic voltage high		$-40^\circ C$ to $+125^\circ C$	1.3		44	V	
V_{IL}	Logic voltage low		$-40^\circ C$ to $+125^\circ C$	0		0.8	V	
I_{IH}	Input leakage current		$-40^\circ C$ to $+125^\circ C$		0.4	2.25	μA	
I_{IL}	Input leakage current		$-40^\circ C$ to $+125^\circ C$	-1.25	-0.005		μA	
C_{IN}	Logic input capacitance		$-40^\circ C$ to $+125^\circ C$		3.5		pF	
POWER SUPPLY								
I_{DD}	V_{DD} supply current	$V_{DD} = 13.2V$, $V_{SS} = 0V$ Logic inputs = $0V$, $5V$, or V_{DD}	$25^\circ C$	30	44		μA	
			$-40^\circ C$ to $+85^\circ C$			52	μA	
			$-40^\circ C$ to $+125^\circ C$			62	μA	

(1) When V_S is positive, V_D is negative, or when V_S is negative, V_D is positive.

(2) When V_S is at a voltage potential, V_D is floating, or when V_D is at a voltage potential, V_S is floating.

5.11 12V Single Supply: Switching Characteristics

$V_{DD} = +12V \pm 10\%$, $V_{SS} = 0V$, $GND = 0V$ (unless otherwise noted)
Typical at $V_{DD} = +12V$, $V_{SS} = 0V$, $T_A = 25^\circ C$ (unless otherwise noted)

PARAMETER		TEST CONDITIONS	T_A	MIN	TYP	MAX	UNIT
t_{TRAN}	Transition time from control input	$V_S = 8V$ $R_L = 300\Omega$, $C_L = 35pF$ Refer to Transition Time	25°C		100	180	ns
			-40°C to +85°C			220	ns
			-40°C to +125°C			245	ns
t_{ON}	Turn-on time from control input	$V_S = 8V$ $R_L = 300\Omega$, $C_L = 35pF$ Refer to Turn-on and Turn-off Time	25°C		190	235	ns
			-40°C to +85°C			260	ns
			-40°C to +125°C			280	ns
t_{OFF}	Turn-off time from control input	$V_S = 8V$ $R_L = 300\Omega$, $C_L = 35pF$ Refer to Turn-on and Turn-off Time	25°C		160	200	ns
			-40°C to +85°C			220	ns
			-40°C to +125°C			245	ns
t_{BBM}	Break-before-make time delay	$V_S = 8V$, $R_L = 300\Omega$, $C_L = 35pF$ Refer to Break-before-make Time	25°C		30		ns
			-40°C to +85°C		9		ns
			-40°C to +125°C		9		ns
$t_{ON(VDD)}$	Device turn on time (V_{DD} to output)	V_{DD} rise time = 1 μ s $R_L = 300\Omega$, $C_L = 35pF$ Refer to Turn-on (VDD) Time	25°C		0.17		ms
			-40°C to +85°C			0.18	ms
			-40°C to +125°C			0.18	ms
t_{PD}	Propagation delay	$R_L = 50\Omega$, $C_L = 5pF$ Refer to Propagation Delay	25°C		770		ps
Q_{INJ}	Charge injection	$V_S = 6V$, $C_L = 100pF$ Refer to Charge Injection	25°C		12		pC
O_{ISO}	Off-isolation	$R_L = 50\Omega$, $C_L = 5pF$ $V_S = 6V$, $f = 100kHz$ Refer to Off Isolation	25°C		-70		dB
O_{ISO}	Off-isolation	$R_L = 50\Omega$, $C_L = 5pF$ $V_S = 6V$, $f = 1MHz$ Refer to Off Isolation	25°C		-50		dB
X_{TALK}	Crosstalk	$R_L = 50\Omega$, $C_L = 5pF$ $V_S = 6V$, $f = 100kHz$ Refer to Crosstalk	25°C		-112		dB
X_{TALK}	Crosstalk	$R_L = 50\Omega$, $C_L = 5pF$ $V_S = 6V$, $f = 1MHz$ Refer to Crosstalk	25°C		-93		dB
BW	-3dB Bandwidth	$R_L = 50\Omega$, $C_L = 5pF$ $V_S = 6V$ Refer to Bandwidth	25°C		50		MHz
I_L	Insertion loss	$R_L = 50\Omega$, $C_L = 5pF$ $V_S = 6V$, $f = 1MHz$	25°C		-0.25		dB
ACPSRR	AC Power Supply Rejection Ratio	$V_{PP} = 0.62V$ on V_{DD} and V_{SS} $R_L = 50\Omega$, $C_L = 5pF$, $f = 1MHz$ Refer to ACPSRR	25°C		-70		dB
THD+N	Total Harmonic Distortion + Noise	$V_{PP} = 6V$, $V_{BIAS} = 6V$ $R_L = 10k\Omega$, $C_L = 5pF$, $f = 20Hz$ to 20kHz Refer to THD + Noise	25°C		0.001		%
$C_{S(OFF)}$	Source off capacitance	$V_S = 6V$, $f = 1MHz$	25°C		52		pF
$C_{D(OFF)}$	Drain off capacitance	$V_S = 6V$, $f = 1MHz$	25°C		68		pF
$C_{S(ON)}$, $C_{D(ON)}$	On capacitance	$V_S = 6V$, $f = 1MHz$	25°C		170		pF

5.12 ±5V Dual Supply: Electrical Characteristics

$V_{DD} = +5V \pm 10\%$, $V_{SS} = -5V \pm 10\%$, GND = 0V (unless otherwise noted)

Typical at $V_{DD} = +5V$, $V_{SS} = -5V$, $T_A = 25^\circ C$ (unless otherwise noted)

PARAMETER		TEST CONDITIONS	T_A	MIN	TYP	MAX	UNIT	
ANALOG SWITCH								
R_{ON}	On-resistance	$V_S = -4.5V$ to $+4.5V$ $I_D = -10mA$ Refer to On-Resistance	25°C		3.3	6.3	Ω	
			-40°C to +85°C			7.6	Ω	
			-40°C to +125°C			8.5	Ω	
ΔR_{ON}	On-resistance mismatch between channels	$V_S = -4.5V$ to $+4.5V$ $I_D = -10mA$ Refer to On-Resistance	25°C		0.07	0.22	Ω	
			-40°C to +85°C			0.23	Ω	
			-40°C to +125°C			0.25	Ω	
$R_{ON\ FLAT}$	On-resistance flatness	$V_S = -4.5V$ to $+4.5V$ $I_D = -10mA$ Refer to On-Resistance	25°C		1	2	Ω	
			-40°C to +85°C			2.1	Ω	
			-40°C to +125°C			2.2	Ω	
$R_{ON\ DRIFT}$	On-resistance drift	$V_S = 0V$, $I_S = -10mA$ Refer to On-Resistance	-40°C to +125°C		0.015		$\Omega/^\circ C$	
$I_{S(OFF)}$	Source off leakage current ⁽¹⁾	$V_{DD} = +5.5V$, $V_{SS} = -5.5V$ Switch state is off $V_S = +4.5V / -4.5V$ $V_D = -4.5V / +4.5V$ Refer to Off-Leakage Current	25°C	-0.4	0.05	0.4	nA	
			-40°C to +85°C		-2		2	nA
			-40°C to +125°C		-16		16	nA
$I_{D(OFF)}$	Drain off leakage current ⁽¹⁾	$V_{DD} = +5.5V$, $V_{SS} = -5.5V$ Switch state is off $V_S = +4.5V / -4.5V$ $V_D = -4.5V / +4.5V$ Refer to Off-Leakage Current	25°C	-1	0.12	1	nA	
			-40°C to +85°C		-5		5	nA
			-40°C to +125°C		-35		35	nA
$I_{S(ON)}$ $I_{D(ON)}$	Channel on leakage current ⁽²⁾	$V_{DD} = +5.5V$, $V_{SS} = -5.5V$ Switch state is on $V_S = V_D = \pm 4.5V$ Refer to On-Leakage Current	25°C	-0.4	0.05	0.4	nA	
			-40°C to +85°C		-2		2	nA
			-40°C to +125°C		-16		16	nA
LOGIC INPUTS (SEL / EN pins)								
V_{IH}	Logic voltage high		-40°C to +125°C	1.3		44	V	
V_{IL}	Logic voltage low		-40°C to +125°C	0		0.8	V	
I_{IH}	Input leakage current		-40°C to +125°C		0.4	2	μA	
I_{IL}	Input leakage current		-40°C to +125°C	-1.2	-0.005		μA	
C_{IN}	Logic input capacitance		-40°C to +125°C		3.5		pF	
POWER SUPPLY								
I_{DD}	V_{DD} supply current	$V_{DD} = +5.5V$, $V_{SS} = -5.5V$ Logic inputs = 0V, 5V, or V_{DD}	25°C		28	38	μA	
			-40°C to +85°C			44	μA	
			-40°C to +125°C			55	μA	
I_{SS}	V_{SS} supply current	$V_{DD} = +5.5V$, $V_{SS} = -5.5V$ Logic inputs = 0V, 5V, or V_{DD}	25°C		6	8.4	μA	
			-40°C to +85°C			11	μA	
			-40°C to +125°C			20	μA	

(1) When V_S is positive, V_D is negative, or when V_S is negative, V_D is positive.

(2) When V_S is at a voltage potential, V_D is floating, or when V_D is at a voltage potential, V_S is floating.

5.13 ±5V Dual Supply: Switching Characteristics

$V_{DD} = +5V \pm 10\%$, $V_{SS} = -5V \pm 10\%$, GND = 0V (unless otherwise noted)

Typical at $V_{DD} = +5V$, $V_{SS} = -5V$, $T_A = 25^\circ\text{C}$ (unless otherwise noted)

PARAMETER		TEST CONDITIONS	T_A	MIN	TYP	MAX	UNIT
t_{TRAN}	Transition time from control input	$V_S = 3V$ $R_L = 300\Omega$, $C_L = 35\text{pF}$ Refer to Transition Time	25°C		135	210	ns
			-40°C to +85°C			250	ns
			-40°C to +125°C			285	ns
t_{ON}	Turn-on time from control input	$V_S = 3V$ $R_L = 300\Omega$, $C_L = 35\text{pF}$ Refer to Turn-on and Turn-off Time	25°C		140	290	ns
			-40°C to +85°C			315	ns
			-40°C to +125°C			340	ns
t_{OFF}	Turn-off time from control input	$V_S = 3V$ $R_L = 300\Omega$, $C_L = 35\text{pF}$ Refer to Turn-on and Turn-off Time	25°C		170	250	ns
			-40°C to +85°C			270	ns
			-40°C to +125°C			295	ns
t_{BBM}	Break-before-make time delay	$V_S = 3V$, $R_L = 300\Omega$, $C_L = 35\text{pF}$ Refer to Break-before-make Time	25°C		32		ns
			-40°C to +85°C		7		ns
			-40°C to +125°C		7		ns
$t_{\text{ON}}(\text{VDD})$	Device turn on time (V_{DD} to output)	V_{DD} rise time = 1 μs $R_L = 300\Omega$, $C_L = 35\text{pF}$ Refer to Turn-on (VDD) Time	25°C		0.17		ms
			-40°C to +85°C			0.18	ms
			-40°C to +125°C			0.18	ms
t_{PD}	Propagation delay	$R_L = 50\Omega$, $C_L = 5\text{pF}$ Refer to Propagation Delay	25°C		670		ps
Q_{INJ}	Charge injection	$V_S = 0V$, $C_L = 100\text{pF}$ Refer to Charge Injection	25°C		9		pC
O_{ISO}	Off-isolation	$R_L = 50\Omega$, $C_L = 5\text{pF}$ $V_S = 0V$, $f = 100\text{kHz}$ Refer to Off Isolation	25°C		-70		dB
O_{ISO}	Off-isolation	$R_L = 50\Omega$, $C_L = 5\text{pF}$ $V_S = 0V$, $f = 1\text{MHz}$ Refer to Off Isolation	25°C		-50		dB
X_{TALK}	Crosstalk	$R_L = 50\Omega$, $C_L = 5\text{pF}$ $V_S = 0V$, $f = 100\text{kHz}$ Refer to Crosstalk	25°C		-117		dB
X_{TALK}	Crosstalk	$R_L = 50\Omega$, $C_L = 5\text{pF}$ $V_S = 0V$, $f = 1\text{MHz}$ Refer to Crosstalk	25°C		-94		dB
BW	-3dB Bandwidth	$R_L = 50\Omega$, $C_L = 5\text{pF}$ $V_S = 0V$ Refer to Bandwidth	25°C		55		MHz
I_L	Insertion loss	$R_L = 50\Omega$, $C_L = 5\text{pF}$ $V_S = 0V$, $f = 1\text{MHz}$	25°C		-0.28		dB
ACPSRR	AC Power Supply Rejection Ratio	$V_{PP} = 0.62V$ on V_{DD} and V_{SS} $R_L = 50\Omega$, $C_L = 5\text{pF}$, $f = 1\text{MHz}$ Refer to ACPSRR	25°C		-70		dB
THD+N	Total Harmonic Distortion + Noise	$V_{PP} = 5V$, $V_{\text{BIAS}} = 0V$ $R_L = 10\text{k}\Omega$, $C_L = 5\text{pF}$, $f = 20\text{Hz}$ to 20kHz Refer to THD + Noise	25°C		0.001		%
$C_{\text{S(OFF)}}$	Source off capacitance	$V_S = 0V$, $f = 1\text{MHz}$	25°C		54		pF
$C_{\text{D(OFF)}}$	Drain off capacitance	$V_S = 0V$, $f = 1\text{MHz}$	25°C		72		pF
$C_{\text{S(ON)}}$, $C_{\text{D(ON)}}$	On capacitance	$V_S = 0V$, $f = 1\text{MHz}$	25°C		170		pF

5.14 Typical Characteristics

at $T_A = 25^\circ\text{C}$ (unless otherwise noted)

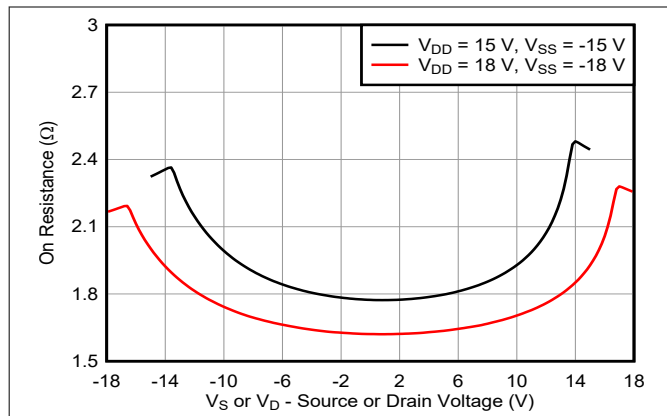

Figure 5-1. On-Resistance vs Source or Drain Voltage – Dual Supply

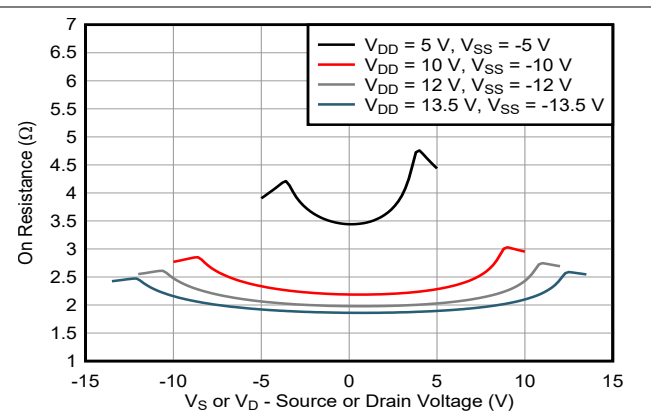

Figure 5-2. On-Resistance vs Source or Drain Voltage – Dual Supply

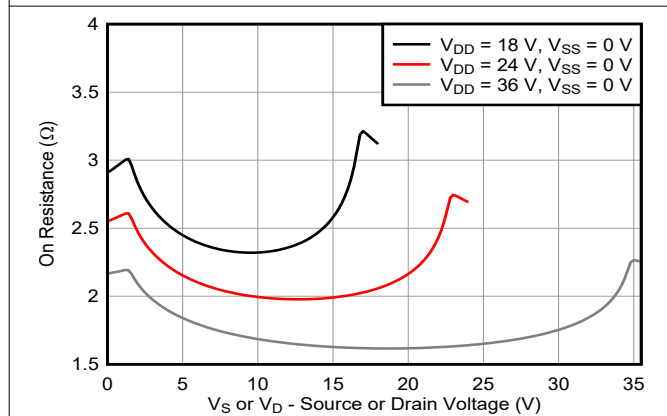

Figure 5-3. On-Resistance vs Source or Drain Voltage – Single Supply

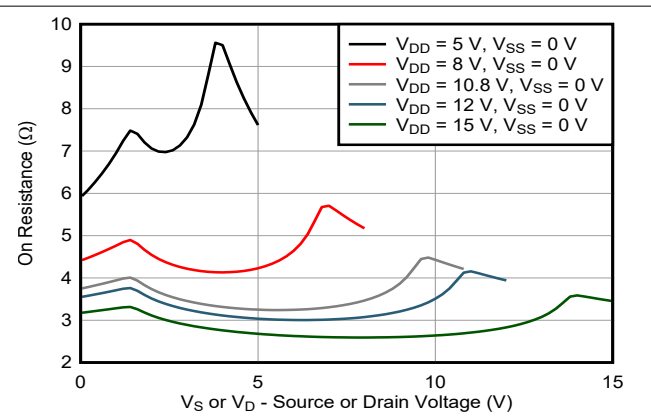

Figure 5-4. On-Resistance vs Source or Drain Voltage – Single Supply

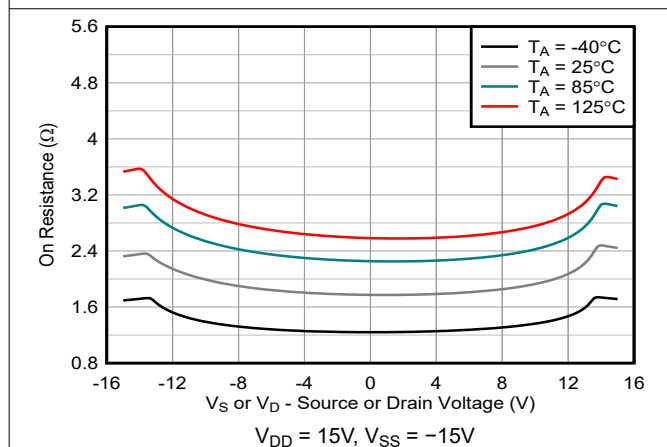

Figure 5-5. On-Resistance vs Temperature

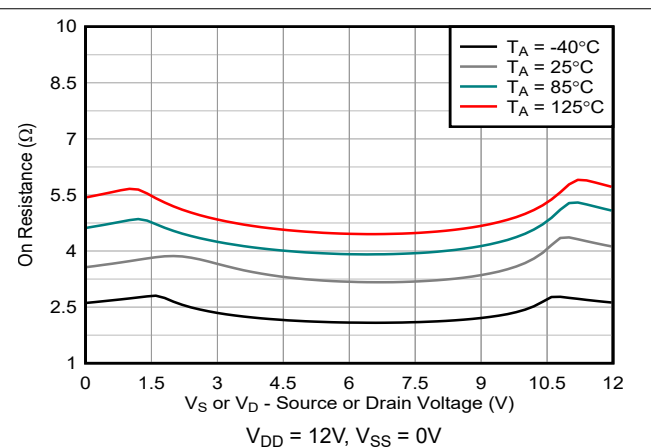

Figure 5-6. On-Resistance vs Temperature

5.14 Typical Characteristics (continued)

at $T_A = 25^\circ\text{C}$ (unless otherwise noted)

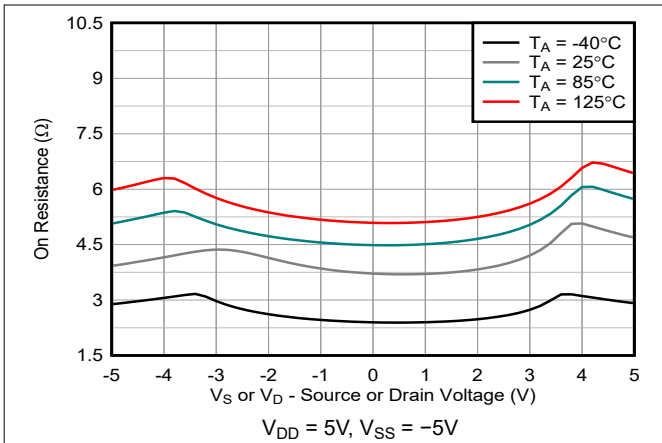

Figure 5-7. On-Resistance vs Temperature

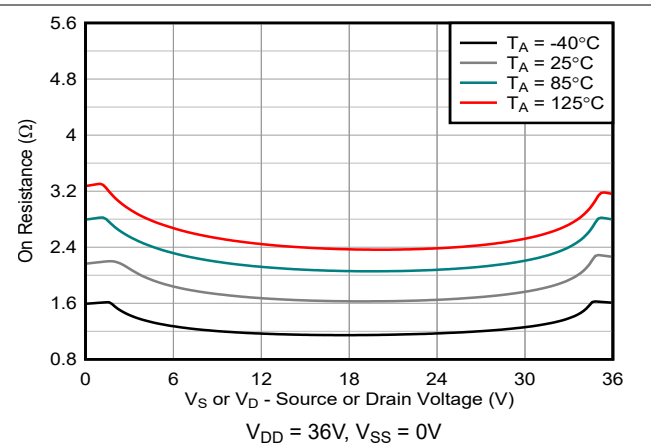

Figure 5-8. On-Resistance vs Temperature

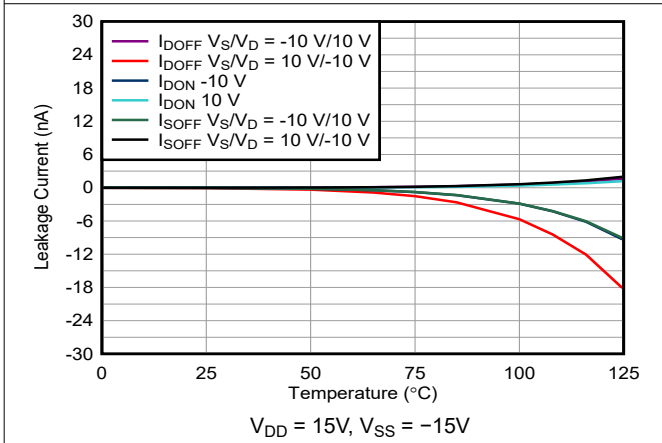

Figure 5-9. On-Leakage vs Temperature

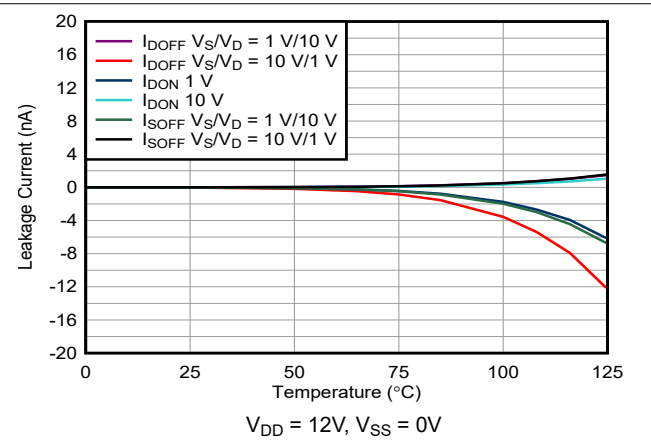

Figure 5-10. On-Leakage vs Temperature

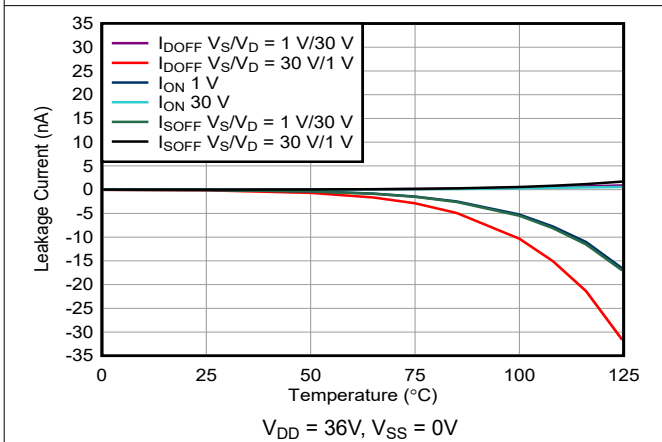

Figure 5-11. On-Leakage vs Temperature

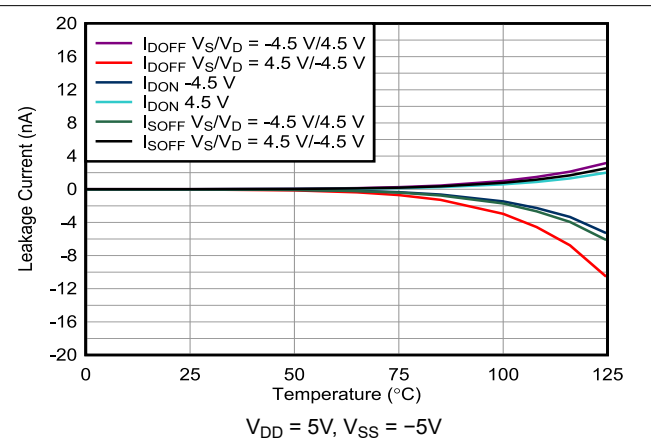

Figure 5-12. On-Leakage vs Temperature

5.14 Typical Characteristics (continued)

at $T_A = 25^\circ\text{C}$ (unless otherwise noted)

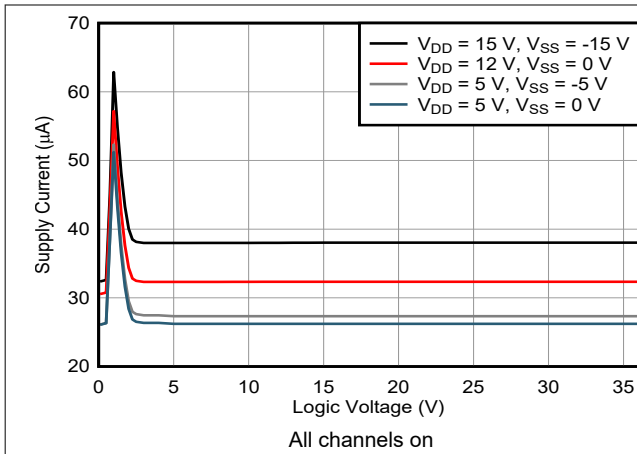

Figure 5-13. Supply Current vs Logic Voltage

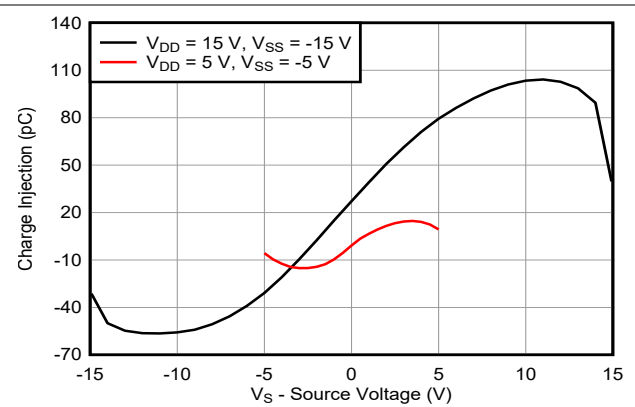

Figure 5-14. Charge Injection vs Source Voltage – Dual Supply

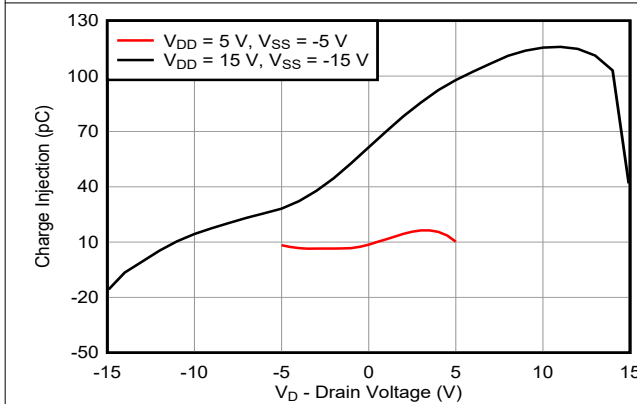

Figure 5-15. Charge Injection vs Drain Voltage – Dual Supply

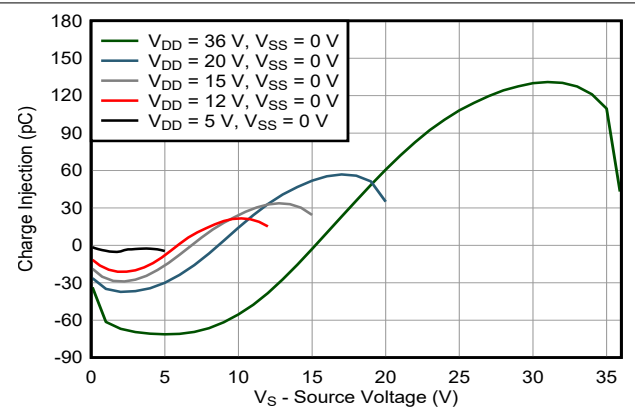

Figure 5-16. Charge Injection vs Source Voltage – Single Supply

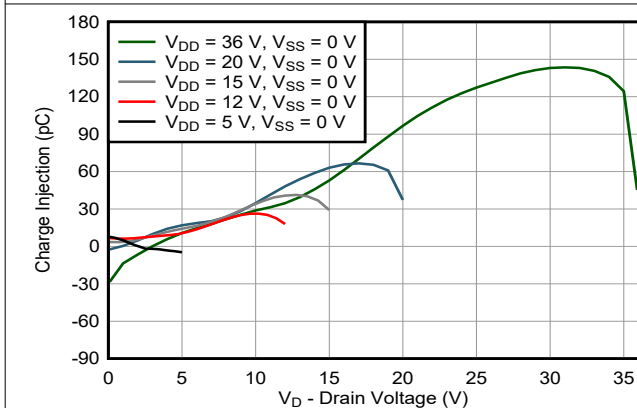

Figure 5-17. Charge Injection vs Drain Voltage – Single Supply

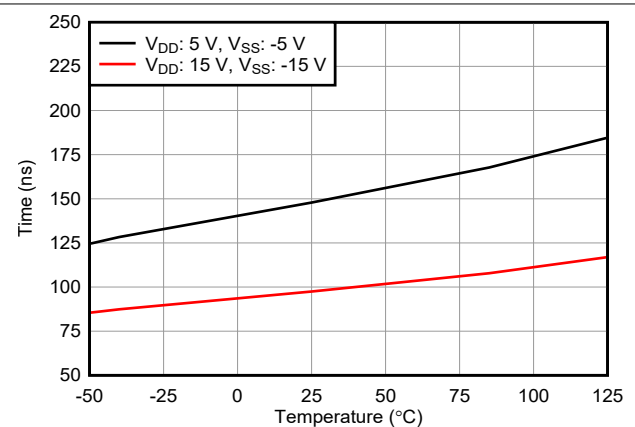

Figure 5-18. $T_{\text{TRANSITION}}$ vs Temperature

5.14 Typical Characteristics (continued)

at $T_A = 25^\circ\text{C}$ (unless otherwise noted)

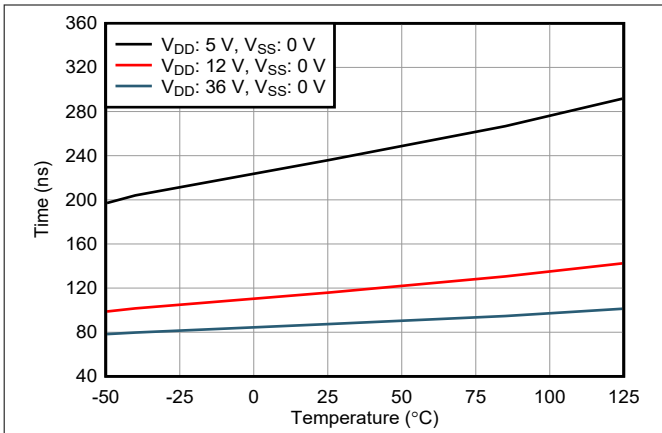

Figure 5-19. $T_{\text{TRANSITION}}$ vs Temperature

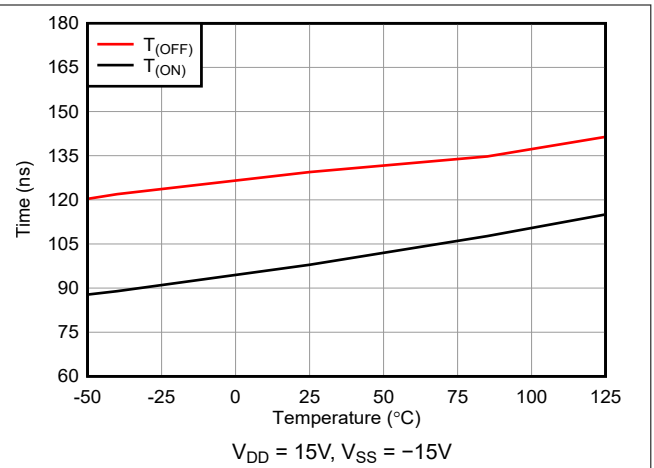

Figure 5-20. T_{ON} (EN) and T_{OFF} (EN) vs Temperature

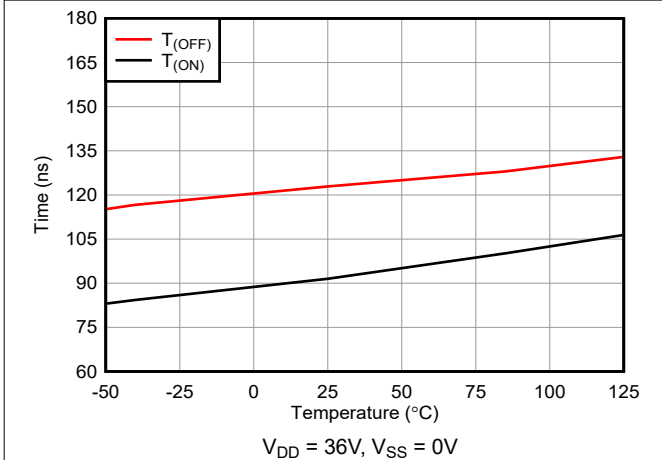

Figure 5-21. T_{ON} (EN) and T_{OFF} (EN) vs Temperature

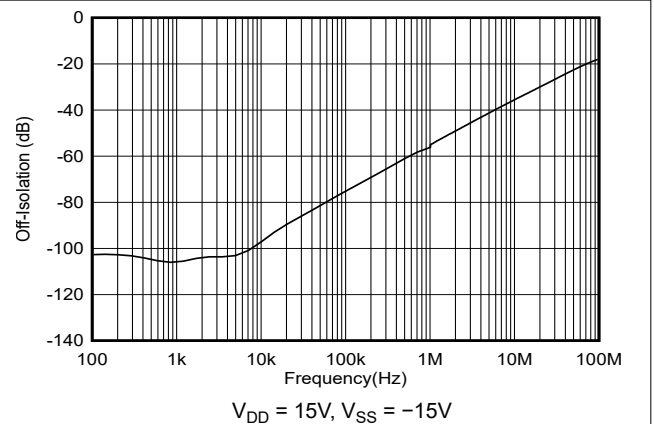

Figure 5-22. Off-Isolation vs Frequency

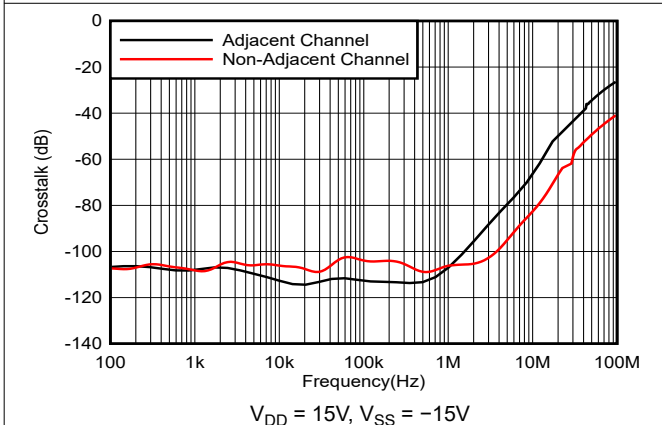

Figure 5-23. Crosstalk vs Frequency

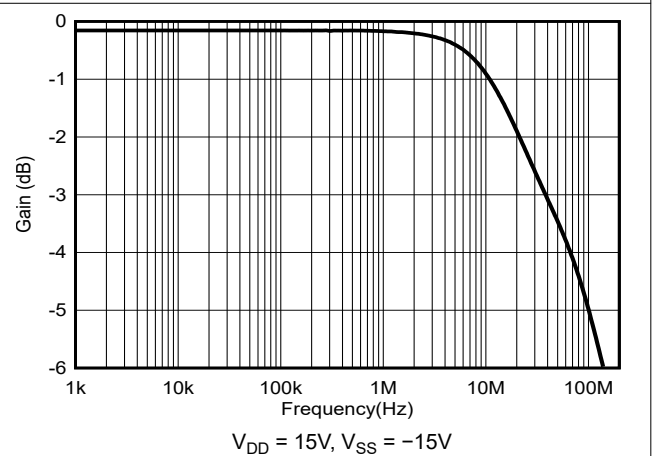

Figure 5-24. On Response vs Frequency

5.14 Typical Characteristics (continued)

at $T_A = 25^\circ\text{C}$ (unless otherwise noted)

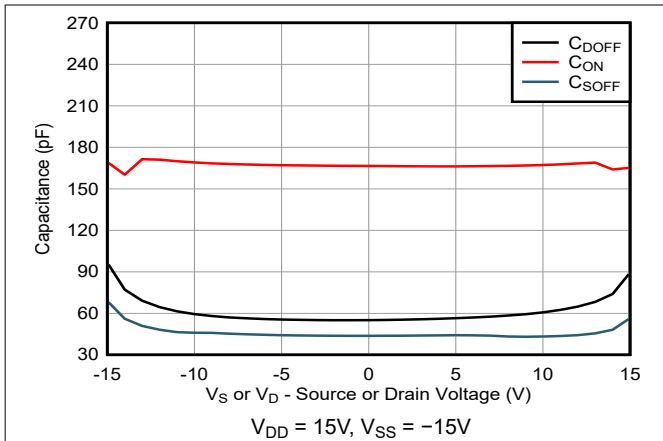

Figure 5-25. Capacitance vs Source or Drain Voltage

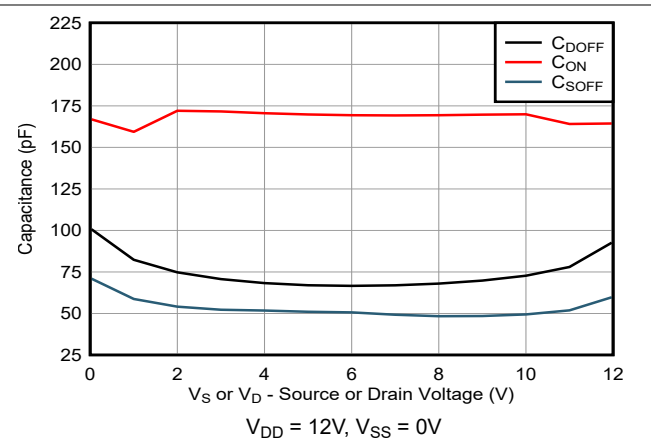

Figure 5-26. Capacitance vs Source or Drain Voltage

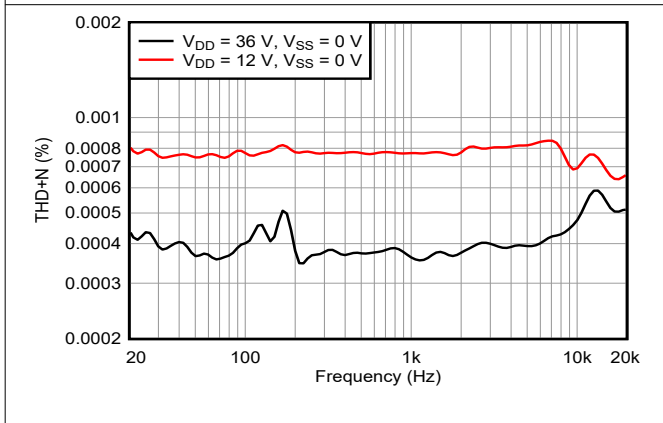

Figure 5-27. THD+N vs Frequency – Single Supply

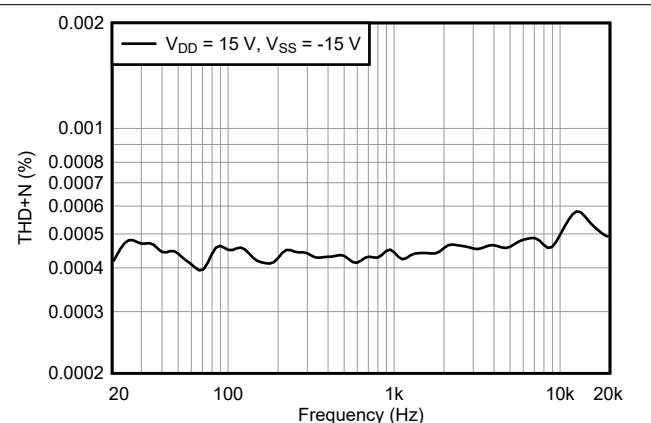

Figure 5-28. THD+N vs Frequency – Dual Supply

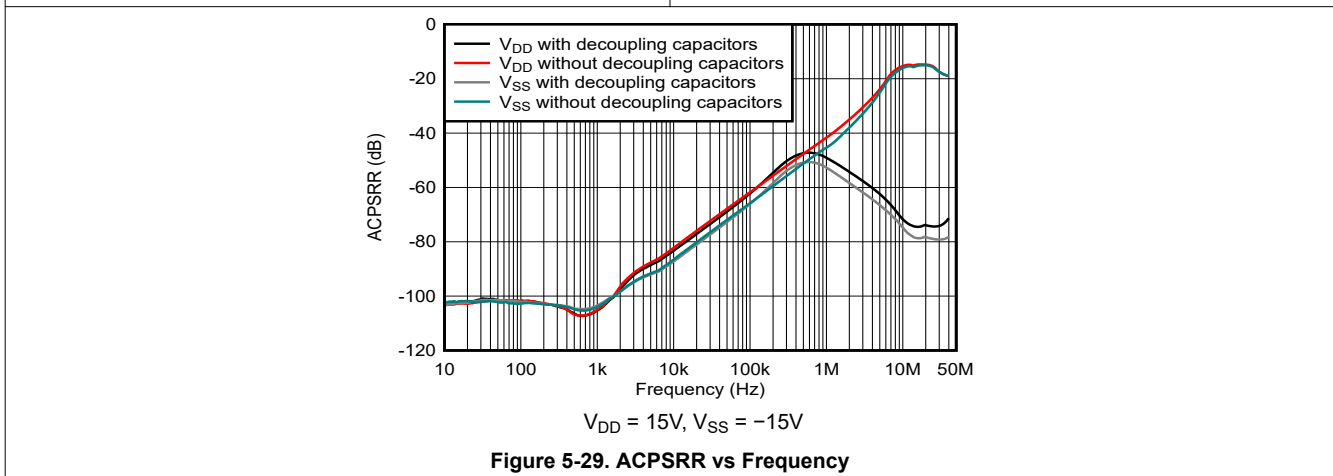

Figure 5-29. ACPSRR vs Frequency

6 Parameter Measurement Information

6.1 On-Resistance

The on-resistance of a device is the ohmic resistance between the source (Sx) and drain (D) pins of the device. The on-resistance varies with input voltage and supply voltage. The symbol R_{ON} is used to denote on-resistance. Figure 6-1 shows the measurement setup used to measure R_{ON} . Voltage (V) and current (I_{SD}) are measured using this setup, and R_{ON} is computed with $R_{ON} = V / I_{SD}$.

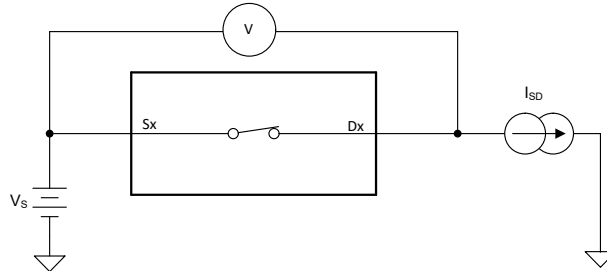

Figure 6-1. On-Resistance Measurement Setup

6.2 Off-Leakage Current

There are two types of leakage currents associated with a switch during the off state:

- Source off-leakage current
- Drain off-leakage current

Source leakage current is defined as the leakage current flowing into or out of the source pin when the switch is off. This current is denoted by the symbol $I_{S(OFF)}$.

Drain leakage current is defined as the leakage current flowing into or out of the drain pin when the switch is off. This current is denoted by the symbol $I_{D(OFF)}$.

Figure 6-2 shows the setup used to measure both off-leakage currents.

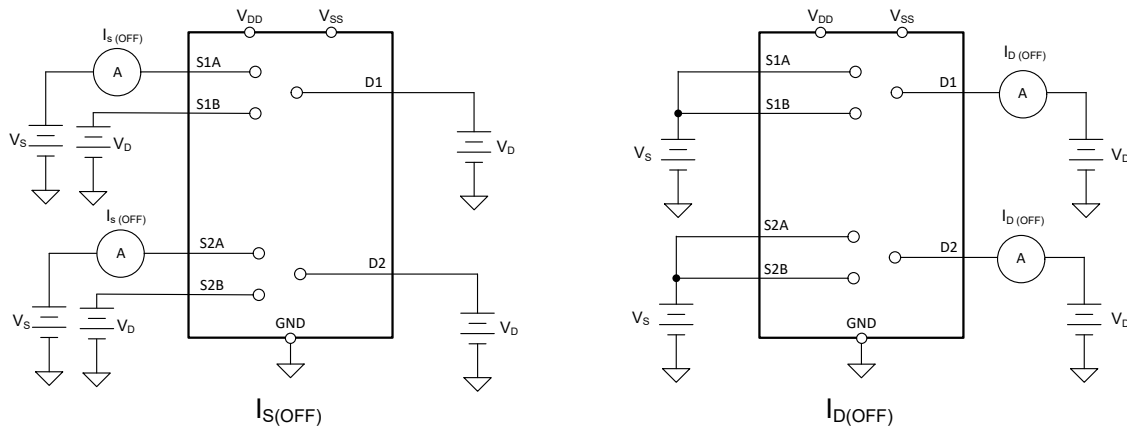

Figure 6-2. Off-Leakage Measurement Setup

6.3 On-Leakage Current

Source on-leakage current is defined as the leakage current flowing into or out of the source pin when the switch is on. This current is denoted by the symbol $I_{S(ON)}$.

Drain on-leakage current is defined as the leakage current flowing into or out of the drain pin when the switch is on. This current is denoted by the symbol $I_{D(ON)}$.

Either the source pin or drain pin is left floating during the measurement. Figure 6-3 shows the circuit used for measuring the on-leakage current, denoted by $I_{S(ON)}$ or $I_{D(ON)}$.

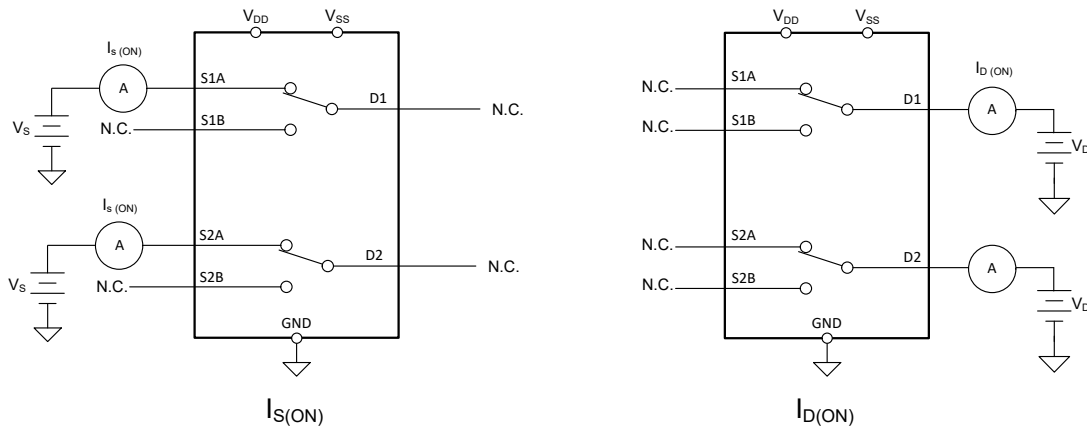

Figure 6-3. On-Leakage Measurement Setup

6.4 Transition Time

Transition time is defined as the time taken by the output of the device to rise or fall 90% after the address signal has risen or fallen past the logic threshold. The 90% transition measurement is utilized to provide the timing of the device. System level timing can then account for the time constant added from the load resistance and load capacitance. Figure 6-4 shows the setup used to measure transition time, denoted by the symbol $t_{TRANSITION}$.

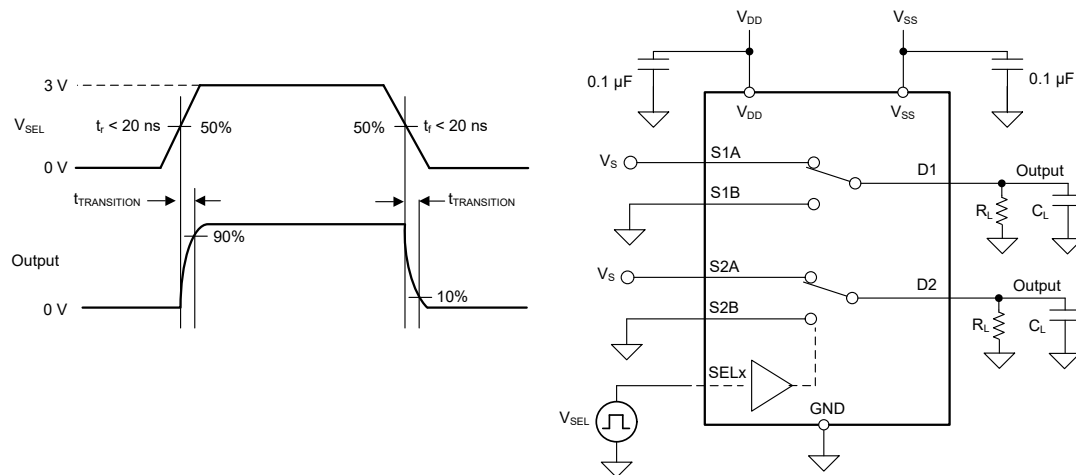

Figure 6-4. Transition-Time Measurement Setup

6.5 $t_{ON(EN)}$ and $t_{OFF(EN)}$

Turn-on time is defined as the time taken by the output of the device to rise to 90% after the enable has risen past the logic threshold. The 90% measurement is utilized to provide the timing of the device. System level timing can then account for the time constant added from the load resistance and load capacitance. Figure 6-5 shows the setup used to measure turn-on time, denoted by the symbol $t_{ON(EN)}$.

Turn-off time is defined as the time taken by the output of the device to fall to 10% after the enable has fallen past the logic threshold. The 10% measurement is utilized to provide the timing of the device. System level timing can then account for the time constant added from the load resistance and load capacitance. Figure 6-5 shows the setup used to measure turn-off time, denoted by the symbol $t_{OFF(EN)}$.

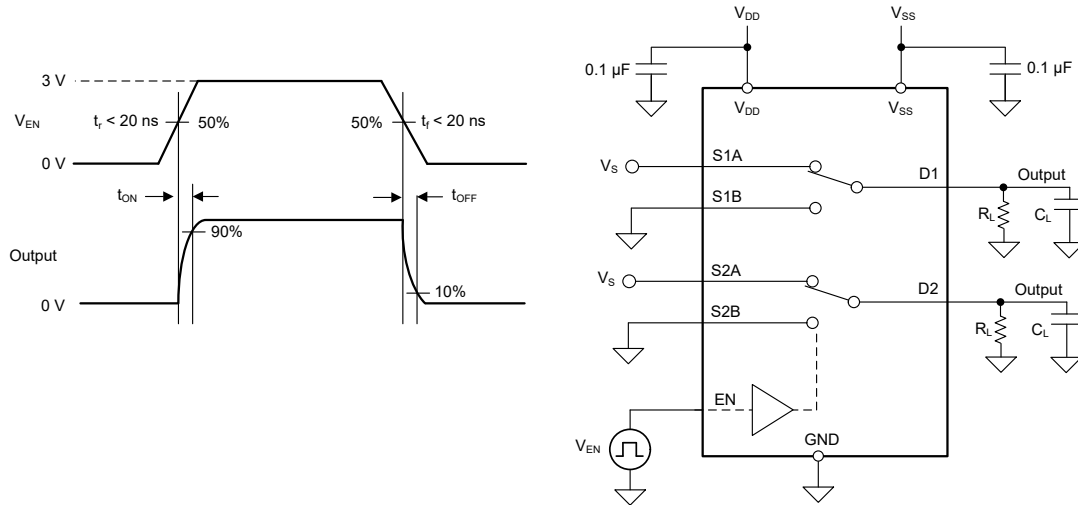

Figure 6-5. Turn-On and Turn-Off Time Measurement Setup

6.6 Break-Before-Make

Break-before-make delay is a safety feature that prevents two inputs from connecting when the device is switching. The output first breaks from the on-state switch before making the connection with the next on-state switch. The time delay between the *break* and the *make* is known as break-before-make delay. Figure 6-6 shows the setup used to measure break-before-make delay, denoted by the symbol $t_{OPEN(BBM)}$.

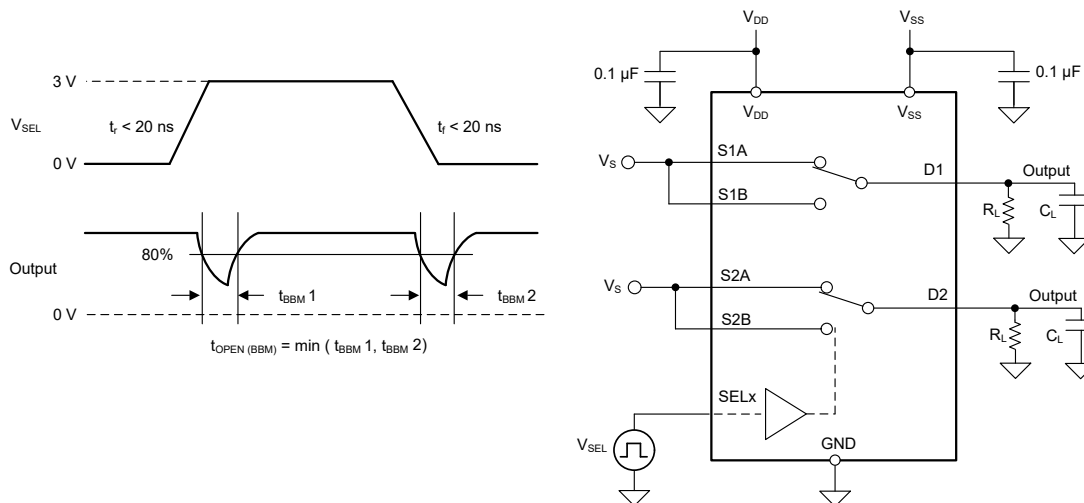

Figure 6-6. Break-Before-Make Delay Measurement Setup

6.7 $t_{ON(VDD)}$ Time

The $t_{ON(VDD)}$ time is defined as the time taken by the output of the device to rise to 90% after the supply has risen past the supply threshold. The 90% measurement is used to provide the timing of the device turning on in the system. Figure 6-7 shows the setup used to measure turn on time, denoted by the symbol $t_{ON(VDD)}$.

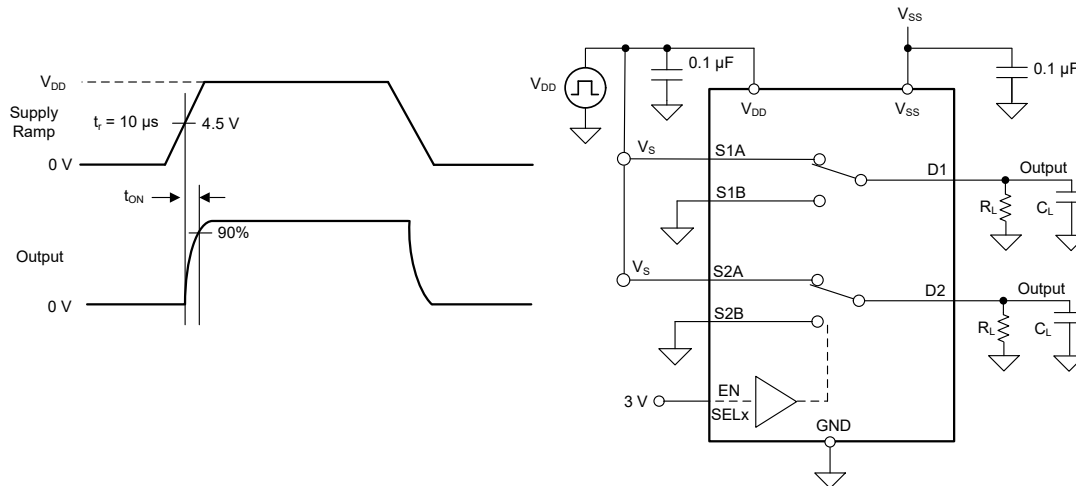

Figure 6-7. $t_{ON(VDD)}$ Time Measurement Setup

6.8 Propagation Delay

Propagation delay is defined as the time taken by the output of the device to rise or fall 50% after the input signal has risen or fallen past the 50% threshold. Figure 6-8 shows the setup used to measure propagation delay, denoted by the symbol t_{PD} .

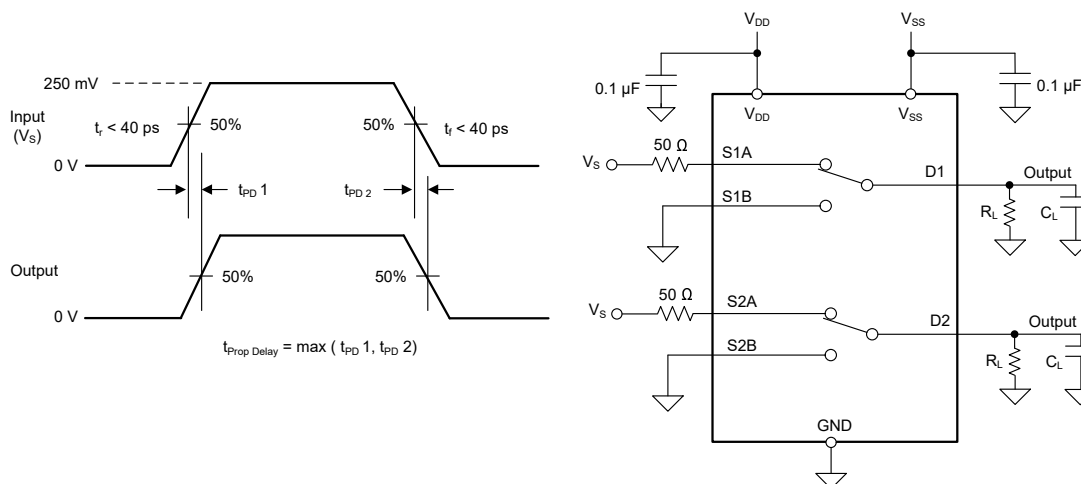

Figure 6-8. Propagation Delay Measurement Setup

6.9 Charge Injection

The TMUX6236 has a transmission-gate topology. Any mismatch in capacitance between the NMOS and PMOS transistors results in a charge injected into the drain or source during the falling or rising edge of the gate signal. The amount of charge injected into the source or drain of the device is known as charge injection, and is denoted by the symbol Q_{INJ} . Figure 6-9 shows the setup used to measure charge injection from source (Sx) to drain (D).

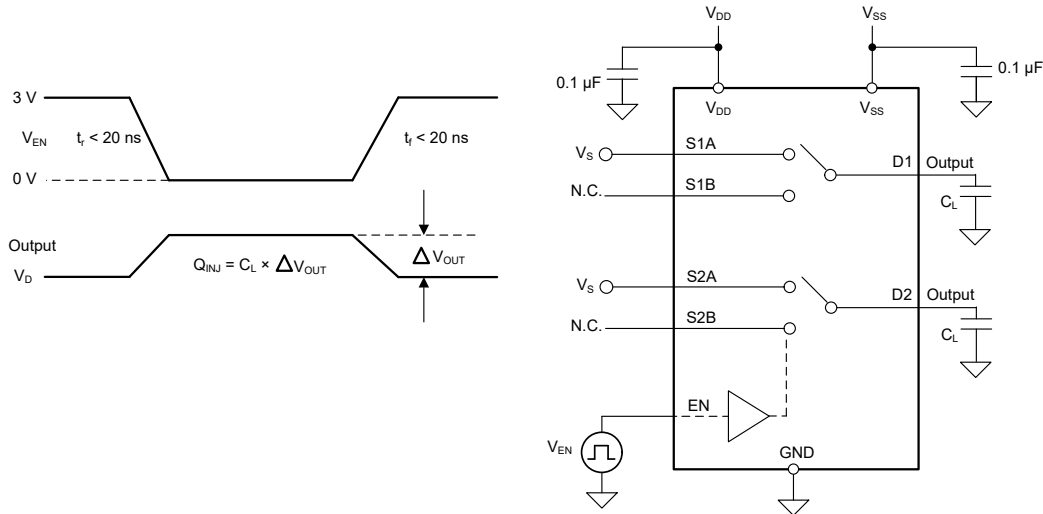

Figure 6-9. Charge-Injection Measurement Setup

6.10 Off Isolation

Off isolation is defined as the ratio of the signal at the drain pin (D) of the device when a signal is applied to the source pin (Sx) of an off-channel. Figure 6-10 shows the setup used to measure, and the equation used to calculate off isolation.

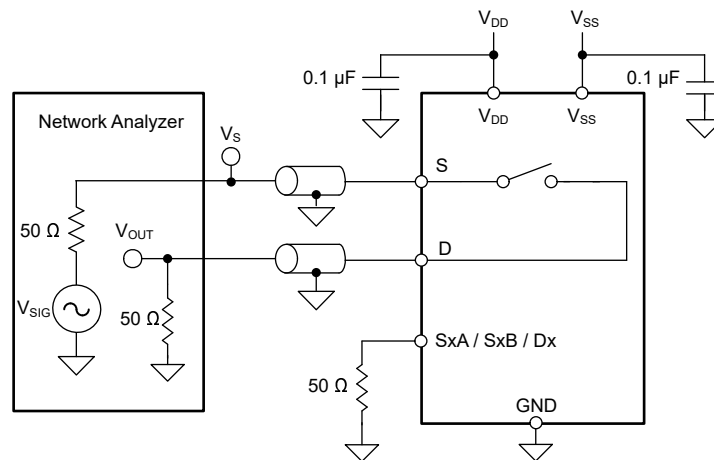

Figure 6-10. Off Isolation Measurement Setup

6.11 Crosstalk

Crosstalk is defined as the ratio of the signal at the drain pin (D) of a different channel, when a signal is applied at the source pin (Sx) of an on-channel. [Figure 6-11](#) shows the setup used to measure and the equation used to calculate crosstalk.

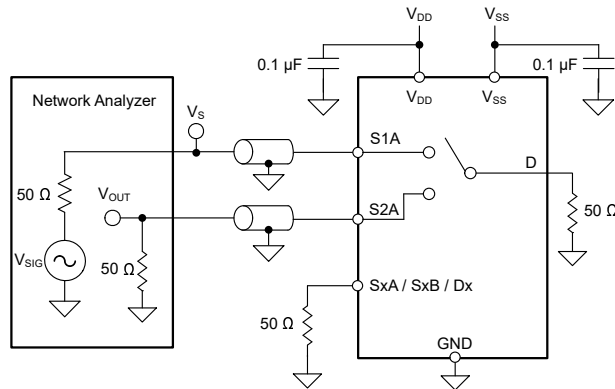

Figure 6-11. Crosstalk Measurement Setup

6.12 Bandwidth

Bandwidth is defined as the range of frequencies that are attenuated by less than 3 dB when the input is applied to the source pin (Sx) of an on-channel, and the output is measured at the drain pin (D) of the device. [Figure 6-12](#) shows the setup used to measure bandwidth.

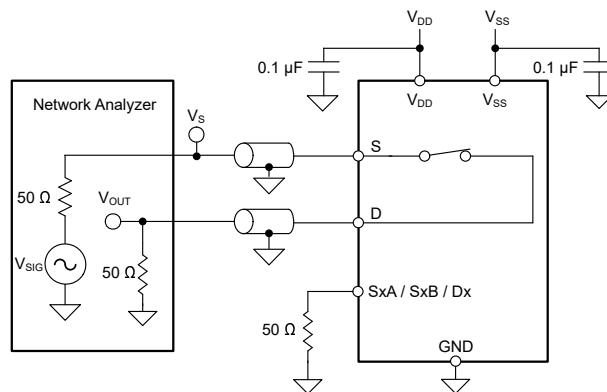

Figure 6-12. Bandwidth Measurement Setup

6.13 THD + Noise

The total harmonic distortion (THD) of a signal is a measurement of the harmonic distortion, and is defined as the ratio of the sum of the powers of all harmonic components to the power of the fundamental frequency at the mux output. The on-resistance of the device varies with the amplitude of the input signal and results in distortion when the drain pin is connected to a low-impedance load. Total harmonic distortion plus noise is denoted as THD.

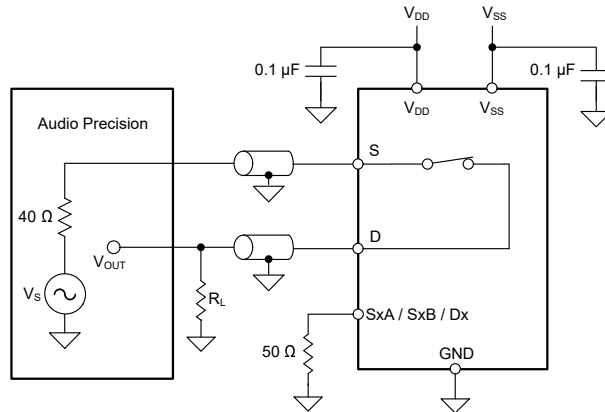

Figure 6-13. THD Measurement Setup

6.14 Power Supply Rejection Ratio (PSRR)

PSRR measures the ability of a device to prevent noise and spurious signals that appear on the supply voltage pin from coupling to the output of the switch. The DC voltage on the device supply is modulated by a sine wave of 620mVPP. The ratio of the amplitude of signal on the output to the amplitude of the modulated signal is the ACPSRR. A high ratio represents a high degree of tolerance to supply rail variation.

Figure 6-14 shows how the decoupling capacitors reduce high frequency noise on the supply pins. This helps stabilize the supply and immediately filter as much of the supply noise as possible.

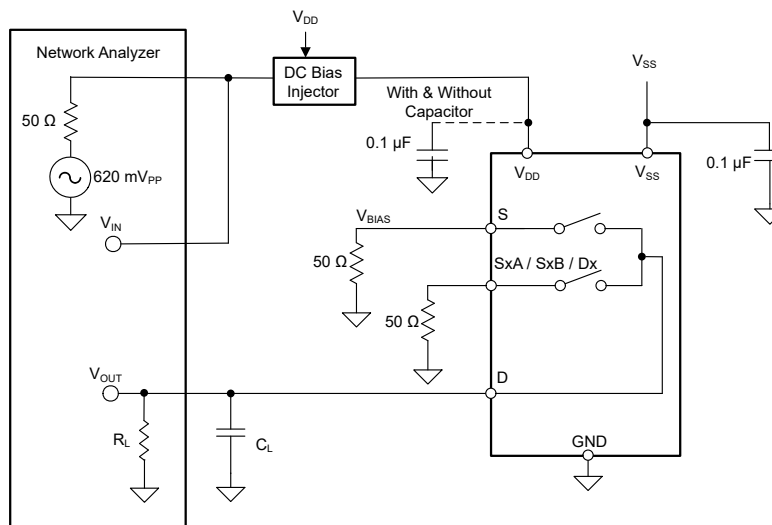
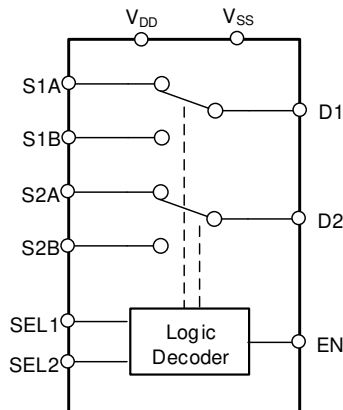

Figure 6-14. ACPSRR Measurement Setup

7 Detailed Description

7.1 Functional Block Diagram

The TMUX6236 is a 2:1, 2-channel multiplexer or demultiplexer. Each input is turned on or turned off based on the state of the select and enable pins.



7.2 Feature Description

7.2.1 Bidirectional Operation

The TMUX6236 conducts equally well from source (S_x) to drain (D_x) or from drain (D_x) to source (S_x). Each channel has very similar characteristics in both directions and supports both analog and digital signals.

7.2.2 Rail to Rail Operation

The valid signal path input or output voltage for TMUX6236 ranges from V_{SS} to V_{DD} .

7.2.3 1.8V Logic Compatible Inputs

The TMUX6236 has 1.8V logic compatible control for all logic control inputs. 1.8V logic level inputs allows the TMUX6236 to interface with processors that have lower logic I/O rails and eliminates the need for an external translator, which saves both space and bill of materials (BOM) cost. For more information on 1.8V logic implementations, refer to [Simplifying Design with 1.8V logic Muxes and Switches](#).

7.2.4 Integrated Pull-Down Resistor on Logic Pins

The TMUX6236 has internal weak pull-down resistors to GND so that the logic pins are not left floating. The value of this pull-down resistor is approximately $4M\Omega$, but is clamped to about $1\mu A$ at higher voltages. This feature integrates up to three external components and reduces system size and cost.

7.2.5 Fail-Safe Logic

The TMUX6236 supports Fail-Safe Logic on the control input pins (EN and SEL) allowing for operation up to 36V above V_{SS} , regardless of the state of the supply pins. This feature allows voltages on the control pins to be applied before the supply pin, protecting the device from potential damage. Fail-Safe Logic minimizes system complexity by removing the need for power supply sequencing on the logic control pins. For example, the Fail-Safe Logic feature allows the logic input pins of the TMUX6236 to be ramped to +36V while V_{DD} and $V_{SS} = 0V$. The logic control inputs are protected against positive faults of up to +36V in the powered-off condition, but does not offer protection against negative overvoltage conditions.

7.2.6 Latch-Up Immune

Latch-up is a condition where a low impedance path is created between a supply pin and ground. This condition is caused by a trigger (current injection or overvoltage), but once activated, the low impedance path remains even after the trigger is no longer present. This low impedance path may cause system upset or catastrophic damage due to excessive current levels. The latch-up condition typically requires a power cycle to eliminate the low impedance path.

The TMUX6236 is constructed on silicon on insulator (SOI) based process where an oxide layer is added between the PMOS and NMOS transistor of each CMOS switch to prevent parasitic structures from forming. The oxide layer is also known as an insulating trench and prevents triggering of latch up events due to overvoltage or current injections. The latch-up immunity feature allows the TMUX6236 to be used in harsh environments. For more information on latch-up immunity refer to [Using Latch Up Immune Multiplexers to Help Improve System Reliability](#).

7.2.7 Ultra-Low Charge Injection

Figure 7-1 shows how the TMUX6236 device has a transmission gate topology. Any mismatch in the stray capacitance associated with the NMOS and PMOS causes an output level change whenever the switch is opened or closed.

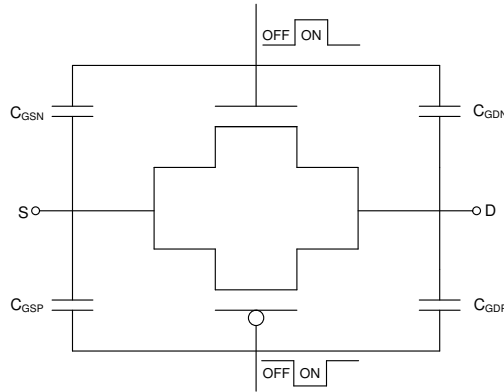

Figure 7-1. Transmission Gate Topology

The TMUX6236 contains specialized architecture to reduce charge injection on the Drain (Dx). To further reduce charge injection in a sensitive application, a compensation capacitor (Cp) can be added on the Source (Sx). This will push excess charge from the switch transition into the compensation capacitor on the Source (Sx) instead of the Drain (Dx). As a general rule, Cp should be 20x larger than the equivalent load capacitance on the Drain (Dx). Figure 7-2 shows charge injection variation with different compensation capacitors on the Source side. This plot was captured on the TMUX6219 as part of the TMUX62xx family with a 100pF load capacitance.

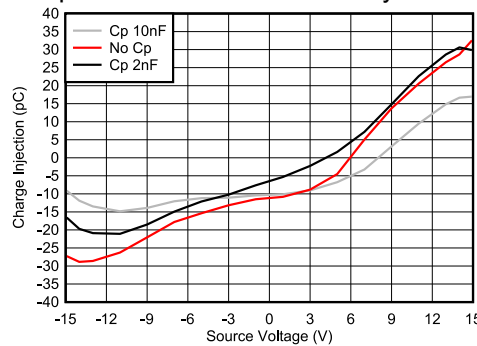

Figure 7-2. Charge Injection Compensation

7.3 Device Functional Modes

When the EN pin of the TMUX6236 is pulled high, one of the switches is closed based on the state of the SEL pin. When the EN pin is pulled low, both of the switches are in an open state regardless of the state of the SEL pin. The control pins can be as high as 36V.

7.4 Truth Tables

Table 7-1 provides the truth tables for the TMUX6236.

Table 7-1. TMUX6236 Truth Table

EN	SELx	Selected Input Connected To Drain (D) Pin
0	X ⁽¹⁾	All channels are off (Hi-Z)
1	0	SxB
1	1	SxA

(1) X denotes *do not care*.

8 Application and Implementation

Note

Information in the following applications sections is not part of the TI component specification, and TI does not warrant its accuracy or completeness. TI's customers are responsible for determining suitability of components for their purposes, as well as validating and testing their design implementation to confirm system functionality.

8.1 Application Information

The TMUX6236 is part of the precision switches and multiplexers family of devices. This device operates with dual supplies ($\pm 4.5\text{V}$ to $\pm 18\text{V}$), a single supply (4.5V and 36V), or asymmetric supplies (such as, $V_{DD} = 5\text{V}$ and $V_{SS} = -8\text{V}$), and offers rail-to-rail input and output. The TMUX6236 offers low R_{ON} , low on and off leakage currents and ultra-low charge injection performance. These features make the TMUX6236 a precision, robust, high-performance analog multiplexer for high-voltage, industrial applications.

8.2 Typical Application

Differential reference signal switching is one application for the TMUX6236. AC reference signals are utilized in a variety of use cases as a stable reference in signal processing. Often times a differential signal is needed to reduce noise and keep signal integrity. To easily swap the direction and frequency of this reference signal, a 2:1, 2 channel precision multiplexer like the TMUX6236 can be used. [Figure 8-1](#) shows a circuit example utilizing the TMUX6236 to control the AC reference signals. The switch can easily be configured for a differential signal on either X1 or X2. Additionally, if both SEL pins are low, then the output will be set to ground so that there is no active operation and reduce power consumption. The break-before-make feature allows transferring of a signal from one port to another, without shorting the inputs together. This device also offers low charge injection, which makes this device suitable for high precision systems.

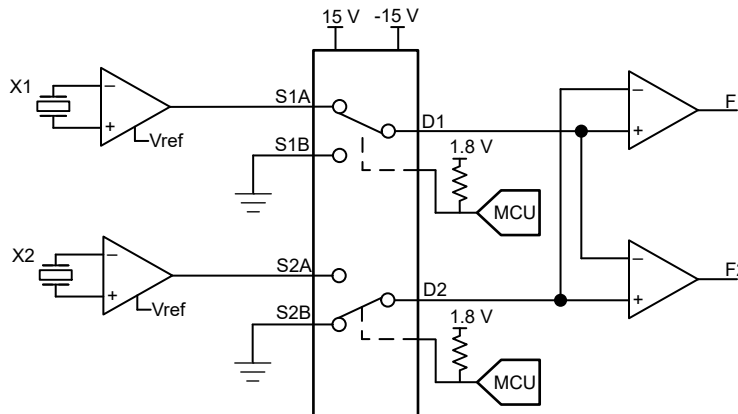

Figure 8-1. Differential Reference Switching

8.2.1 Design Requirements

For this design example, use the parameters listed in [Table 8-1](#).

Table 8-1. Design Parameters

PARAMETERS	VALUES
Supply (V_{DD})	15V
Supply (V_{SS})	-15V
MUX I/O signal range	-15V to 15V (Rail-to-Rail)
Control logic thresholds	1.8V compatible (up to V_{DD})
EN	EN pulled high to enable the switch

8.2.2 Detailed Design Procedure

The TMUX6236 can operate without any external components except for the supply decoupling capacitors. All inputs passing through the switch must fall within the recommended operating conditions of the TMUX6236, including signal range and continuous current. The signal range for this design can be -15V to $+15\text{V}$ and the maximum continuous current can be up to 330mA for wide-range current measurement with a positive supply of 15V on V_{DD} and negative supply of -15V on V_{SS} (for more information, see [Section 5.4](#)). The TMUX6236 device are bidirectional, single-pole double-throw (SPDT) switches that offer low on-resistance, low leakage, and low power. These features make these devices suitable for precision and power sensitive applications.

8.2.3 Application Curve

The low on-resistance of TMUX6236 and ultra-low charge injection performance make this device an excellent choice for implementing high precision industrial systems. The TMUX6236 contains specialized architecture to reduce charge injection on the Drain side (D) (for more details, see [Section 7.2.7](#)). [Figure 8-2](#) shows the plot for the charge injection versus source voltage for the TMUX6236.

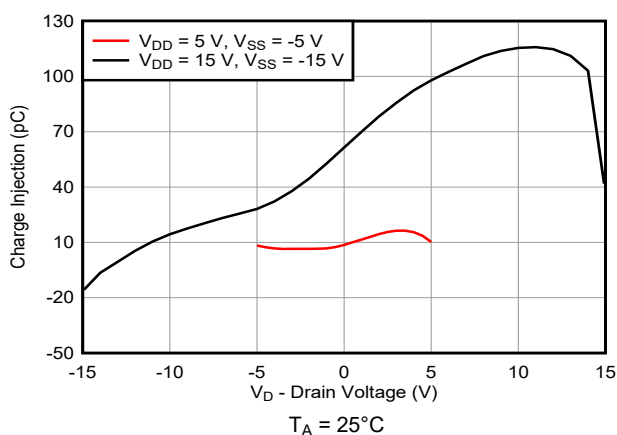

Figure 8-2. Charge Injection vs Drain Voltage

8.3 Power Supply Recommendations

The TMUX6236 operates across a wide supply range of $\pm 4.5\text{V}$ to $\pm 18\text{V}$ (4.5V to 36V in single-supply mode). The device also performs well with asymmetrical supplies such as $V_{DD} = 12\text{V}$ and $V_{SS} = -5\text{V}$.

Power-supply bypassing improves noise margin and prevents switching noise propagation from the supply rails to other components. Good power-supply decoupling is important to achieve optimum performance. For improved supply noise immunity, use a supply decoupling capacitor ranging from $0.1\mu\text{F}$ to $10\mu\text{F}$ at both the V_{DD} and V_{SS} pins to ground. Place the bypass capacitors as close to the power supply pins of the device as possible using low-impedance connections. TI recommends using multi-layer ceramic chip capacitors (MLCCs) that offer low equivalent series resistance (ESR) and inductance (ESL) characteristics for power-supply decoupling purposes. For very sensitive systems or systems in harsh noise environments, avoiding the use of vias for connecting the capacitors to the device pins may offer superior noise immunity. The use of multiple vias in parallel lowers the overall inductance and is beneficial for connections to ground planes. Always ensure the ground (GND) connection is established before supplies are ramped.

8.4 Layout

8.4.1 Layout Guidelines

When a PCB trace turns a corner at a 90° angle, a reflection can occur. A reflection occurs primarily because of the change of width of the trace. At the apex of the turn, the trace width increases to 1.414 times the width. This increase upsets the transmission-line characteristics, especially the distributed capacitance and self-inductance of the trace which results in the reflection. Not all PCB traces can be straight and therefore some traces must turn corners. **Figure 8-3** shows progressively better techniques of rounding corners. Only the last example (BEST) maintains constant trace width and minimizes reflections.

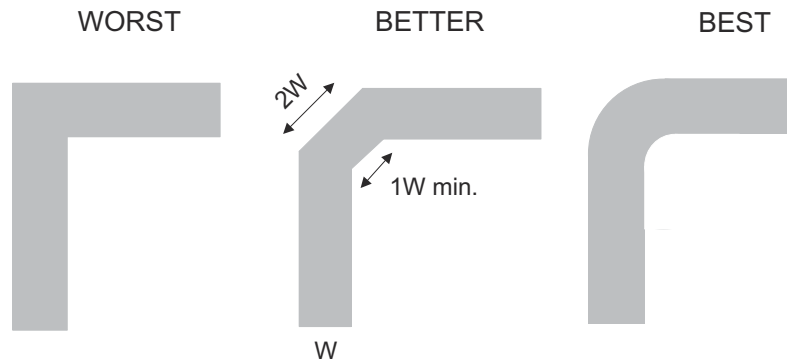

Figure 8-3. Trace Example

Route high-speed signals using a minimum of vias and corners which reduces signal reflections and impedance changes. When a via must be used, increase the clearance size around it to minimize its capacitance. Each via introduces discontinuities in the signal's transmission line and increases the chance of picking up interference from the other layers of the board. Be careful when designing test points; through-hole pins are not recommended at high frequencies.

Some key considerations are:

- For reliable operation, connect a decoupling capacitor ranging from 0.1µF to 10µF between VDD/VSS and GND. TI recommends a 0.1µF and 1µF capacitor, placing the lowest value capacitor as close to the pin as possible. Make sure that the capacitor voltage rating is sufficient for the supply voltage.
- Keep the input lines as short as possible.
- Use a solid ground plane to help reduce electromagnetic interference (EMI) noise pickup.
- Do not run sensitive analog traces in parallel with digital traces. Avoid crossing digital and analog traces if possible, and only make perpendicular crossings when necessary.
- Using multiple vias in parallel will lower the overall inductance and is beneficial for connection to ground planes.

8.4.2 Layout Example

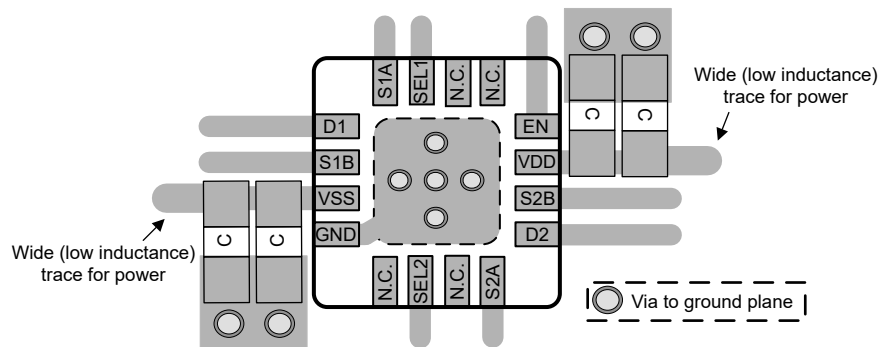

Figure 8-4. TMUX6236RUM Layout Example

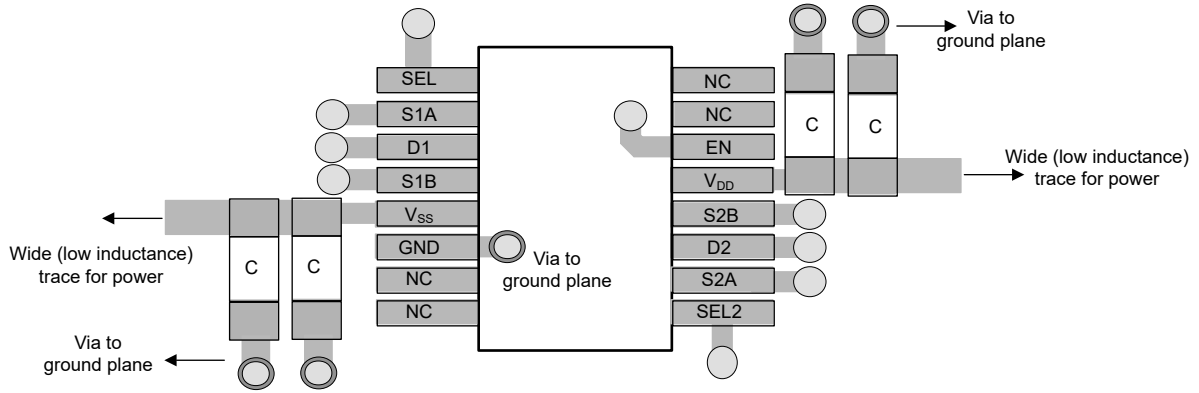

Figure 8-5. TMUX6236PW Layout Example

9 Device and Documentation Support

9.1 Documentation Support

9.1.1 Related Documentation

For related documentation, see the following:

- Texas Instruments, [Eliminate Power Sequencing with Powered-off Protection Signal Switches application brief](#)
- Texas Instruments, [Improve Stability Issues with Low CON Multiplexers application brief](#)
- Texas Instruments, [QFN/SON PCB Attachment application report](#)
- Texas Instruments, [Quad Flatpack No-Lead Logic Packages application report](#)
- Texas Instruments, [Simplifying Design with 1.8V logic Muxes and Switches application brief](#)
- Texas Instruments, [System-Level Protection for High-Voltage Analog Multiplexers application reports](#)
- Texas Instruments, [True Differential, 4 x 2 MUX, Analog Front End, Simultaneous-Sampling ADC Circuit circuit design](#)

9.2 Receiving Notification of Documentation Updates

To receive notification of documentation updates, navigate to the device product folder on ti.com. Click on *Notifications* to register and receive a weekly digest of any product information that has changed. For change details, review the revision history included in any revised document.

9.3 Support Resources

[TI E2E™ support forums](#) are an engineer's go-to source for fast, verified answers and design help — straight from the experts. Search existing answers or ask your own question to get the quick design help you need.

Linked content is provided "AS IS" by the respective contributors. They do not constitute TI specifications and do not necessarily reflect TI's views; see TI's [Terms of Use](#).

9.4 Trademarks

TI E2E™ is a trademark of Texas Instruments.
All trademarks are the property of their respective owners.

9.5 Glossary

[TI Glossary](#) This glossary lists and explains terms, acronyms, and definitions.

9.6 Electrostatic Discharge Caution



This integrated circuit can be damaged by ESD. Texas Instruments recommends that all integrated circuits be handled with appropriate precautions. Failure to observe proper handling and installation procedures can cause damage.

ESD damage can range from subtle performance degradation to complete device failure. Precision integrated circuits may be more susceptible to damage because very small parametric changes could cause the device not to meet its published specifications.

10 Revision History

NOTE: Page numbers for previous revisions may differ from page numbers in the current version.

Changes from Revision B (December 2023) to Revision C (February 2024)	Page
• Corrected pin numbers in the <i>Pin Functions</i> table.....	3

Changes from Revision A (July 2022) to Revision B (December 2023)	Page
• Added the <i>PW</i> package information.....	1

Changes from Revision * (April 2022) to Revision A (July 2022) **Page**

- Changed the status of the data sheet from: *Advanced Information* to: *Production Data* **1**
-

11 Mechanical, Packaging, and Orderable Information

The following pages include mechanical, packaging, and orderable information. This information is the most current data available for the designated devices. This data is subject to change without notice and revision of this document. For browser-based versions of this data sheet, refer to the left-hand navigation.

PACKAGING INFORMATION

Orderable part number	Status (1)	Material type (2)	Package Pins	Package qty Carrier	RoHS (3)	Lead finish/ Ball material (4)	MSL rating/ Peak reflow (5)	Op temp (°C)	Part marking (6)
TMUX6236PWR	Active	Production	TSSOP (PW) 16	2000 LARGE T&R	Yes	NIPDAU	Level-1-260C-UNLIM	-40 to 125	T236
TMUX6236PWR.B	Active	Production	TSSOP (PW) 16	2000 LARGE T&R	Yes	NIPDAU	Level-1-260C-UNLIM	-40 to 125	T236
TMUX6236RUMR	Active	Production	WQFN (RUM) 16	3000 LARGE T&R	Yes	NIPDAU	Level-1-260C-UNLIM	-40 to 125	TMUX T236
TMUX6236RUMR.B	Active	Production	WQFN (RUM) 16	3000 LARGE T&R	Yes	NIPDAU	Level-1-260C-UNLIM	-40 to 125	TMUX T236

(1) **Status:** For more details on status, see our [product life cycle](#).

(2) **Material type:** When designated, preproduction parts are prototypes/experimental devices, and are not yet approved or released for full production. Testing and final process, including without limitation quality assurance, reliability performance testing, and/or process qualification, may not yet be complete, and this item is subject to further changes or possible discontinuation. If available for ordering, purchases will be subject to an additional waiver at checkout, and are intended for early internal evaluation purposes only. These items are sold without warranties of any kind.

(3) **RoHS values:** Yes, No, RoHS Exempt. See the [TI RoHS Statement](#) for additional information and value definition.

(4) **Lead finish/Ball material:** Parts may have multiple material finish options. Finish options are separated by a vertical ruled line. Lead finish/Ball material values may wrap to two lines if the finish value exceeds the maximum column width.

(5) **MSL rating/Peak reflow:** The moisture sensitivity level ratings and peak solder (reflow) temperatures. In the event that a part has multiple moisture sensitivity ratings, only the lowest level per JEDEC standards is shown. Refer to the shipping label for the actual reflow temperature that will be used to mount the part to the printed circuit board.

(6) **Part marking:** There may be an additional marking, which relates to the logo, the lot trace code information, or the environmental category of the part.

Multiple part markings will be inside parentheses. Only one part marking contained in parentheses and separated by a "-" will appear on a part. If a line is indented then it is a continuation of the previous line and the two combined represent the entire part marking for that device.

Important Information and Disclaimer: The information provided on this page represents TI's knowledge and belief as of the date that it is provided. TI bases its knowledge and belief on information provided by third parties, and makes no representation or warranty as to the accuracy of such information. Efforts are underway to better integrate information from third parties. TI has taken and continues to take reasonable steps to provide representative and accurate information but may not have conducted destructive testing or chemical analysis on incoming materials and chemicals. TI and TI suppliers consider certain information to be proprietary, and thus CAS numbers and other limited information may not be available for release.

In no event shall TI's liability arising out of such information exceed the total purchase price of the TI part(s) at issue in this document sold by TI to Customer on an annual basis.

TAPE AND REEL INFORMATION

QUADRANT ASSIGNMENTS FOR PIN 1 ORIENTATION IN TAPE

*All dimensions are nominal

Device	Package Type	Package Drawing	Pins	SPQ	Reel Diameter (mm)	Reel Width W1 (mm)	A0 (mm)	B0 (mm)	K0 (mm)	P1 (mm)	W (mm)	Pin1 Quadrant
TMUX6236PWR	TSSOP	PW	16	2000	330.0	12.4	6.9	5.6	1.6	8.0	12.0	Q1
TMUX6236RUMR	WQFN	RUM	16	3000	330.0	12.4	4.25	4.25	1.15	8.0	12.0	Q2

TAPE AND REEL BOX DIMENSIONS

*All dimensions are nominal

Device	Package Type	Package Drawing	Pins	SPQ	Length (mm)	Width (mm)	Height (mm)
TMUX6236PWR	TSSOP	PW	16	2000	353.0	353.0	32.0
TMUX6236RUMR	WQFN	RUM	16	3000	367.0	367.0	35.0

GENERIC PACKAGE VIEW

RUM 16

WQFN - 0.8 mm max height

4 x 4, 0.65 mm pitch

PLASTIC QUAD FLATPACK - NO LEAD

This image is a representation of the package family, actual package may vary.
Refer to the product data sheet for package details.

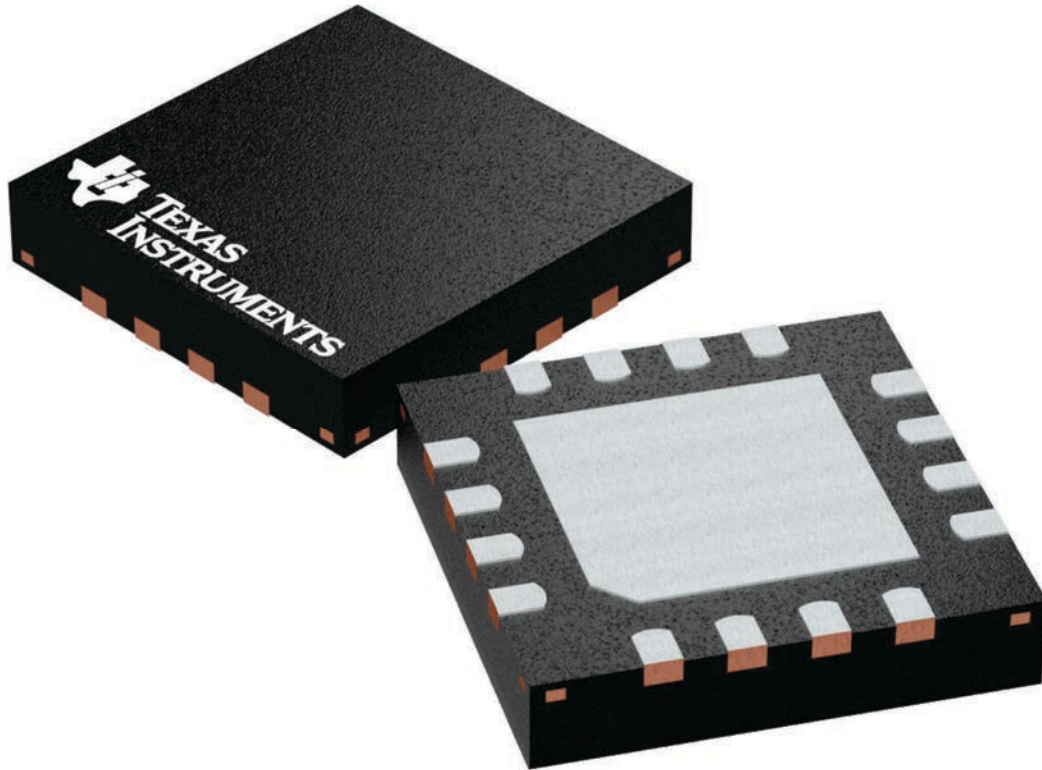

4224843/A

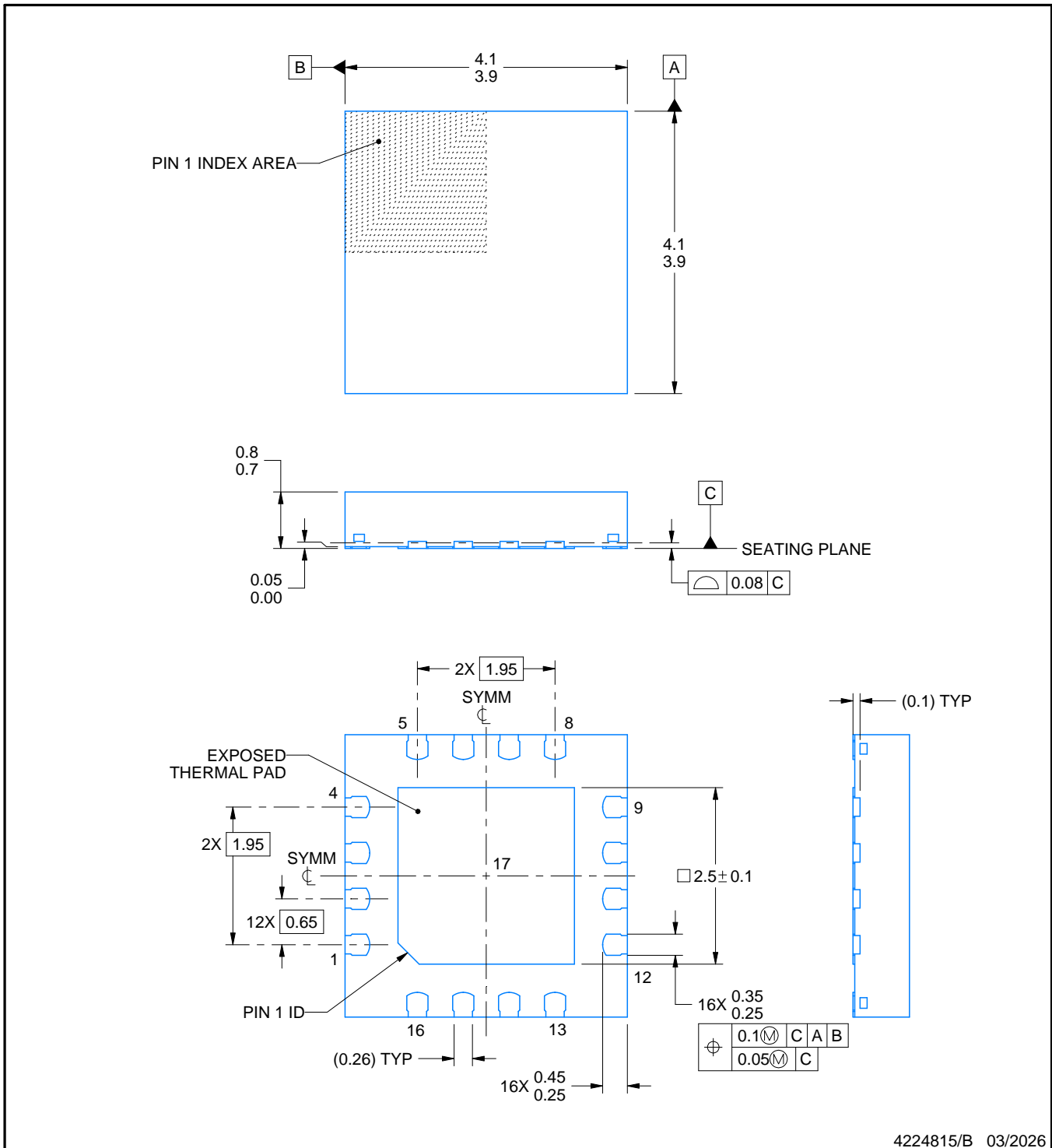
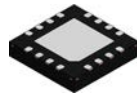

4224815/B 03/2026

NOTES:

1. All linear dimensions are in millimeters. Any dimensions in parenthesis are for reference only. Dimensioning and tolerancing per ASME Y14.5M.
2. This drawing is subject to change without notice.
3. The package thermal pad must be soldered to the printed circuit board for thermal and mechanical performance.

EXAMPLE STENCIL DESIGN

RUM0016E

WQFN - 0.8 mm max height

PLASTIC QUAD FLATPACK - NO LEAD

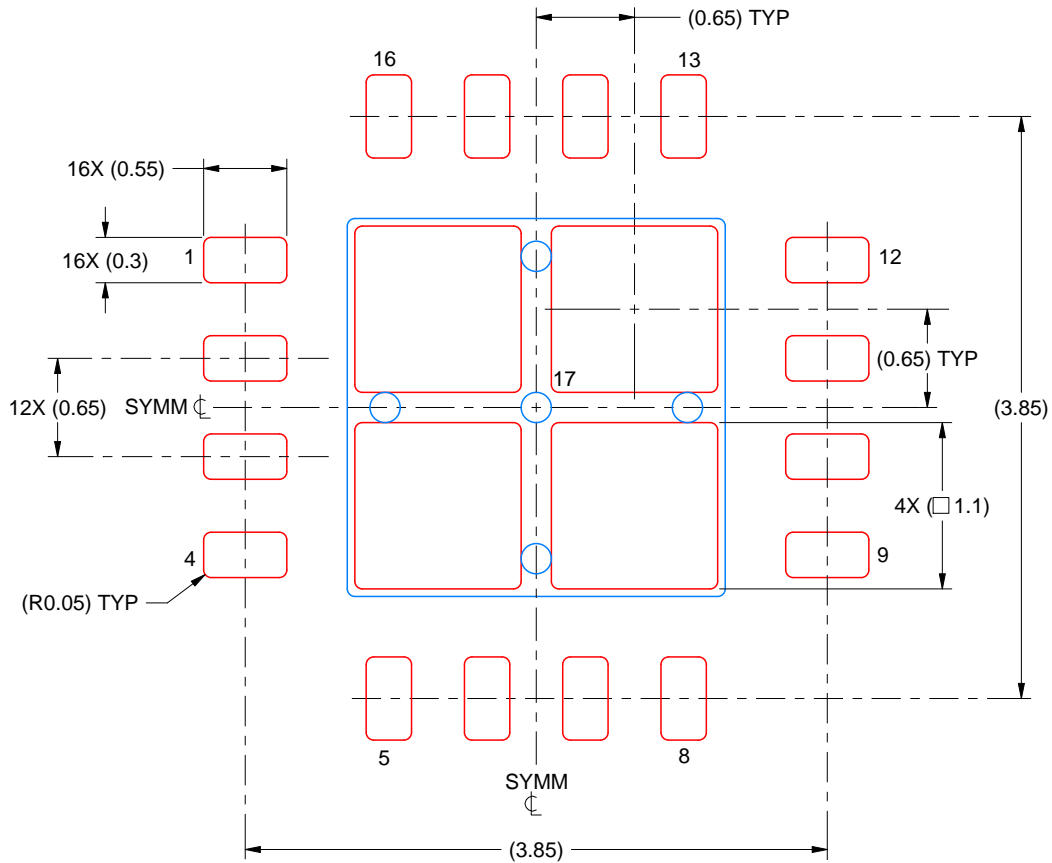

SOLDER PASTE EXAMPLE
BASED ON 0.125 MM THICK STENCIL
SCALE: 20X

EXPOSED PAD 17
77% PRINTED SOLDER COVERAGE BY AREA UNDER PACKAGE

4224815/B 03/2026

NOTES: (continued)

6. Laser cutting apertures with trapezoidal walls and rounded corners may offer better paste release. IPC-7525 may have alternate design recommendations.

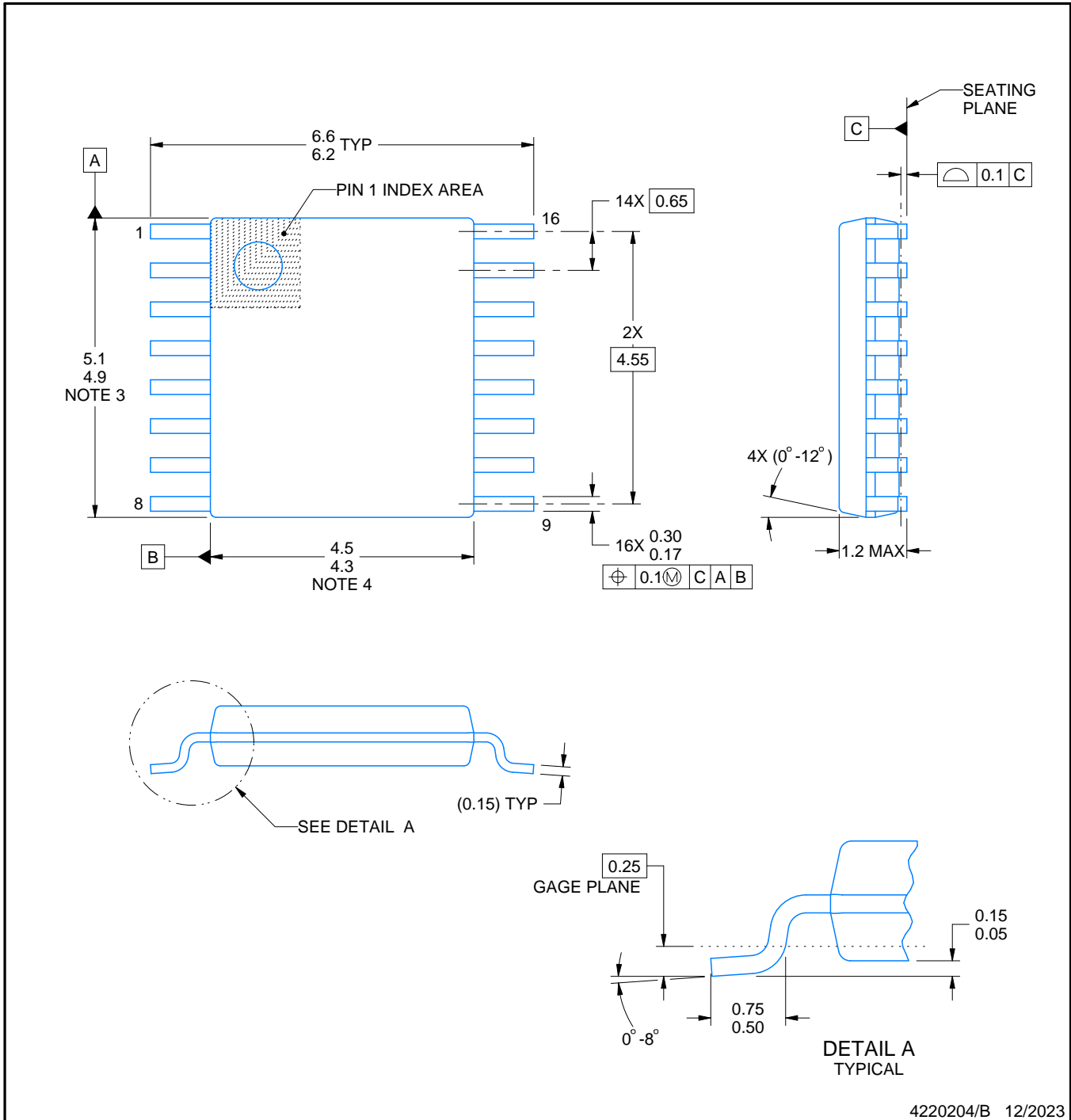
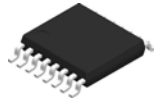

4220204/B 12/2023

NOTES:

1. All linear dimensions are in millimeters. Any dimensions in parenthesis are for reference only. Dimensioning and tolerancing per ASME Y14.5M.
2. This drawing is subject to change without notice.
3. This dimension does not include mold flash, protrusions, or gate burrs. Mold flash, protrusions, or gate burrs shall not exceed 0.15 mm per side.
4. This dimension does not include interlead flash. Interlead flash shall not exceed 0.25 mm per side.
5. Reference JEDEC registration MO-153.

EXAMPLE BOARD LAYOUT

PW0016A

TSSOP - 1.2 mm max height

SMALL OUTLINE PACKAGE

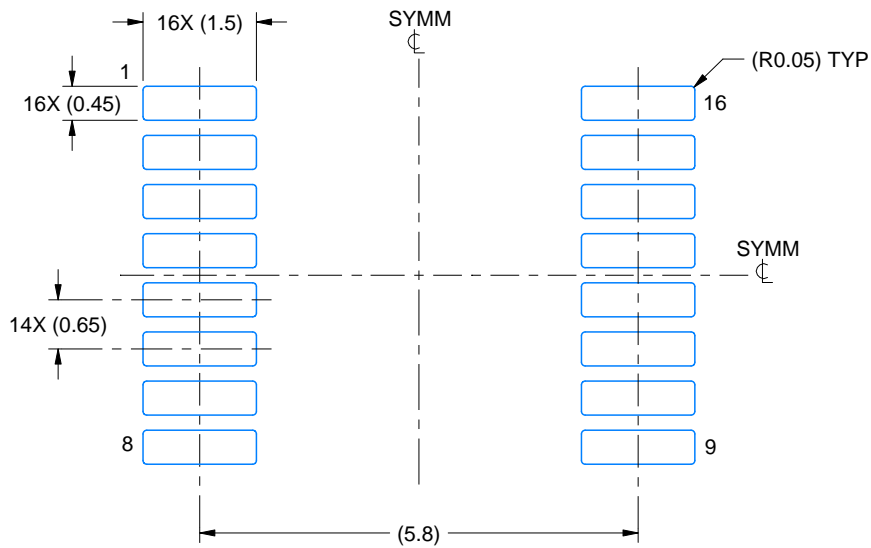

LAND PATTERN EXAMPLE
EXPOSED METAL SHOWN
SCALE: 10X

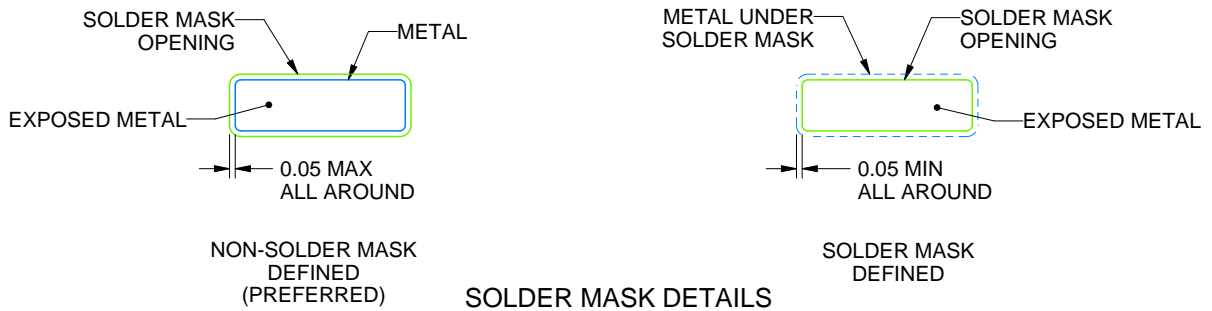

4220204/B 12/2023

NOTES: (continued)

- 6. Publication IPC-7351 may have alternate designs.
- 7. Solder mask tolerances between and around signal pads can vary based on board fabrication site.

EXAMPLE STENCIL DESIGN

PW0016A

TSSOP - 1.2 mm max height

SMALL OUTLINE PACKAGE

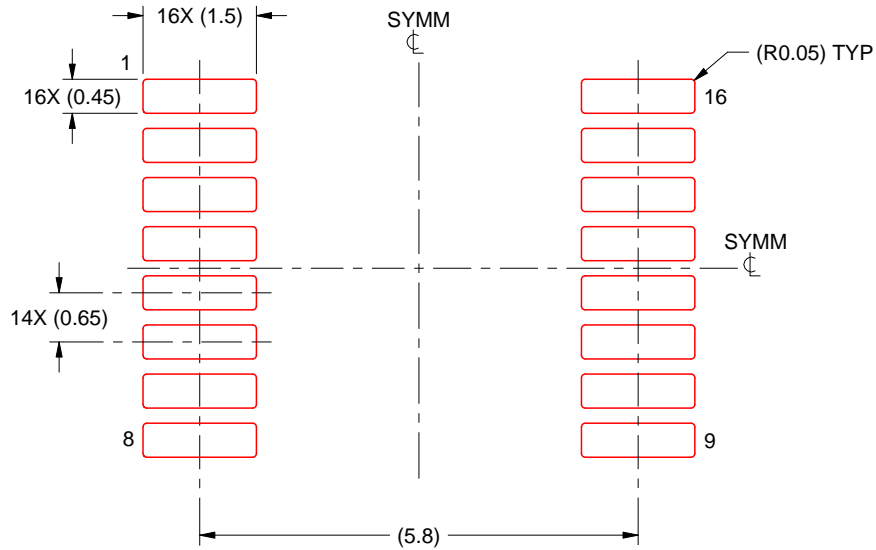

SOLDER PASTE EXAMPLE
BASED ON 0.125 mm THICK STENCIL
SCALE: 10X

4220204/B 12/2023

NOTES: (continued)

8. Laser cutting apertures with trapezoidal walls and rounded corners may offer better paste release. IPC-7525 may have alternate design recommendations.
9. Board assembly site may have different recommendations for stencil design.

IMPORTANT NOTICE AND DISCLAIMER

TI PROVIDES TECHNICAL AND RELIABILITY DATA (INCLUDING DATASHEETS), DESIGN RESOURCES (INCLUDING REFERENCE DESIGNS), APPLICATION OR OTHER DESIGN ADVICE, WEB TOOLS, SAFETY INFORMATION, AND OTHER RESOURCES "AS IS" AND WITH ALL FAULTS, AND DISCLAIMS ALL WARRANTIES, EXPRESS AND IMPLIED, INCLUDING WITHOUT LIMITATION ANY IMPLIED WARRANTIES OF MERCHANTABILITY, FITNESS FOR A PARTICULAR PURPOSE OR NON-INFRINGEMENT OF THIRD PARTY INTELLECTUAL PROPERTY RIGHTS.

These resources are intended for skilled developers designing with TI products. You are solely responsible for (1) selecting the appropriate TI products for your application, (2) designing, validating and testing your application, and (3) ensuring your application meets applicable standards, and any other safety, security, regulatory or other requirements.

These resources are subject to change without notice. TI grants you permission to use these resources only for development of an application that uses the TI products described in the resource. Other reproduction and display of these resources is prohibited. No license is granted to any other TI intellectual property right or to any third party intellectual property right. TI disclaims responsibility for, and you fully indemnify TI and its representatives against any claims, damages, costs, losses, and liabilities arising out of your use of these resources.

TI's products are provided subject to [TI's Terms of Sale](#), [TI's General Quality Guidelines](#), or other applicable terms available either on [ti.com](#) or provided in conjunction with such TI products. TI's provision of these resources does not expand or otherwise alter TI's applicable warranties or warranty disclaimers for TI products. Unless TI explicitly designates a product as custom or customer-specified, TI products are standard, catalog, general purpose devices.

TI objects to and rejects any additional or different terms you may propose.

Copyright © 2026, Texas Instruments Incorporated

Last updated 10/2025