

TPS22960 Low-Input Voltage, Dual-Load Switch With Controlled Turnon

1 Features

- Integrated dual-load switch
- Input voltage range: 1.62V to 5.5V
- Low ON-state resistance
 - $r_{ON} = 342\text{m}\Omega$ at $V_{IN} = 5.5\text{V}$
 - $r_{ON} = 435\text{m}\Omega$ at $V_{IN} = 3.3\text{V}$
 - $r_{ON} = 523\text{m}\Omega$ at $V_{IN} = 2.5\text{V}$
 - $r_{ON} = 737\text{m}\Omega$ at $V_{IN} = 1.8\text{V}$
- 500mA maximum continuous switch current
- Low quiescent current and shutdown current
- Controlled switch output rise time: 75 μs or 660 μs
- Integrated quick output discharge transistor
- ESD performance tested per JESD 22
 - 2000V human body model (A114-B, Class II)
 - 1000V charged-device model (C101)
- 8-pin SOT (DCN) package: 3mm × 3mm
- 8-pin UQFN (RSE) package: 1.5mm × 1.5mm

2 Applications

- GPS Devices
- Cell Phones/PDAs
- MP3 Players
- Digital Cameras

3 Description

The TPS22960 is a small low- r_{ON} dual-channel load switch with controlled turnon. The devices contain two P-channel MOSFETs that can operate over an input voltage range of 1.62V to 5.5V. Each switch is independently controlled by on/off inputs (ON1 and ON2), which are capable of interfacing directly with low-voltage control signals. In TPS22960 a 85 Ω on-chip load resistor is added for quick discharge when the switch is turned off.

The rise time (slew-rate) of the device is internally controlled in order to avoid inrush current, and it can be slowed down if needed using the SR pin: at 3.3V, TPS22960 features a 75 μs rise time with the SR pin tied to ground and 660 μs with the SR pin tied to high.

The TPS22960 is available in a space-saving 8-pin UQFN package and in an 8-pin SOT package. It is characterized for operation over the free-air temperature range of -40°C to 85°C .

Package Information

| PART NUMBER | PACKAGE ⁽¹⁾ | PACKAGE SIZE ⁽²⁾ |
|-------------|------------------------|-----------------------------|
| TPS22960 | DCN (SOT, 8) | 2.90mm × 1.63mm |
| | RSE (UQFN, 8) | 1.50mm × 1.50mm |

(1) For all available packages, see the orderable addendum at the end of the data sheet.

(2) The package size (length × width) is a nominal value and includes pins, where applicable.

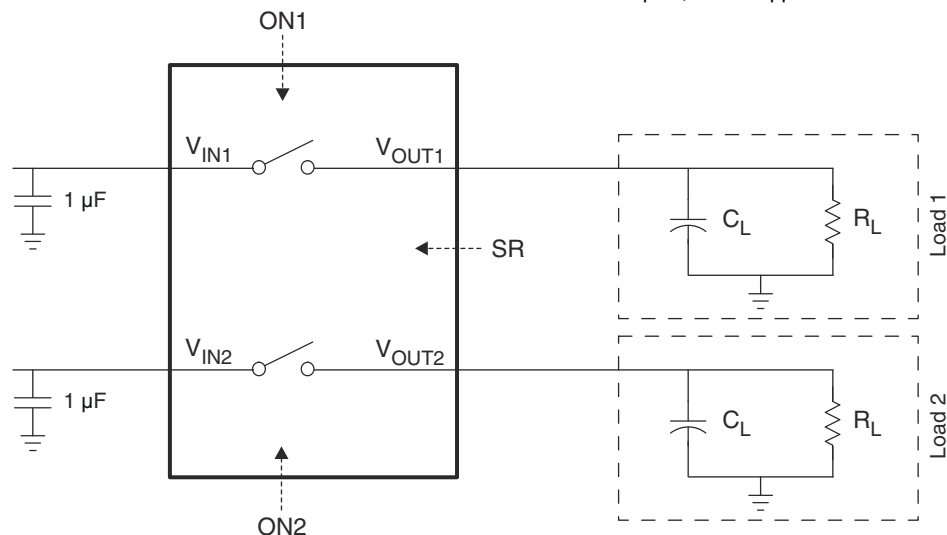

Simplified Diagram



Table of Contents

| | | | |
|--------------------------------------------------|----|------------------------------------------------------------------|----|
| 1 Features | 1 | 7.3 Feature Description..... | 14 |
| 2 Applications | 1 | 7.4 Device Functional Modes..... | 14 |
| 3 Description | 1 | 8 Application and Implementation | 15 |
| 4 Pin Configuration and Functions | 3 | 8.1 Application Information..... | 15 |
| 5 Specifications | 4 | 8.2 Typical Application..... | 15 |
| 5.1 Absolute Maximum Ratings..... | 4 | 8.3 Power Supply Recommendations..... | 16 |
| 5.2 ESD Ratings..... | 4 | 8.4 Layout..... | 17 |
| 5.3 Recommended Operating Conditions..... | 4 | 9 Device and Documentation Support | 19 |
| 5.4 Thermal Information..... | 4 | 9.1 Receiving Notification of Documentation Updates.... | 19 |
| 5.5 Electrical Characteristics..... | 5 | 9.2 Support Resources..... | 19 |
| 5.6 Switching Characteristics..... | 5 | 9.3 Trademarks..... | 19 |
| 5.7 Typical DC Characteristics..... | 6 | 9.4 Electrostatic Discharge Caution..... | 19 |
| 5.8 Typical Switching Characteristics..... | 7 | 9.5 Glossary..... | 19 |
| 6 Parameter Measurement Information | 12 | 10 Revision History | 19 |
| 7 Detailed Description | 13 | 11 Mechanical, Packaging, and Orderable Information | 19 |
| 7.1 Overview..... | 13 | | |
| 7.2 Functional Block Diagram..... | 13 | | |

4 Pin Configuration and Functions

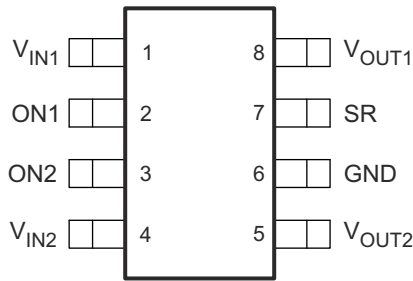

Figure 4-1. DCN Package, 8-pin SOT (Top View)

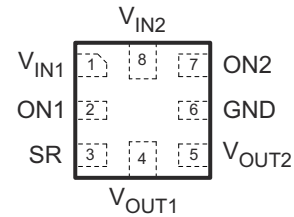

Figure 4-2. RSE Package, 8-pin UQFN (Top View)

Table 4-1. Pin Functions

| NAME | PIN | | I/O | DESCRIPTION |
|-------------------|-----|------|-----|------------------------------------------------------------------------------------------------------------------------------|
| | SOT | UQFN | | |
| V _{IN1} | 1 | 1 | I | Switch 1 input; bypass this input with a ceramic capacitor to GND. |
| ON1 | 2 | 2 | I | Switch 1 control input, active high. Do not leave floating. |
| ON2 | 3 | 7 | I | Switch 2 control input, active high. Do not leave floating. |
| V _{IN2} | 4 | 8 | I | Switch 2 input; bypass this input with a ceramic capacitor to GND. |
| V _{OUT2} | 5 | 5 | O | Switch 2 output. |
| GND | 6 | 6 | — | Ground. |
| SR | 7 | 3 | I | Slew rate control pin. SR = GND translates into a 75- μ s rise time; SR = high translates into a 660- μ s rise time. |
| V _{OUT1} | 8 | 4 | O | Switch 1 output. |

5 Specifications

5.1 Absolute Maximum Ratings

(see ⁽¹⁾)

| | | MIN | MAX | UNIT |
|------------------|-----------------------------------|------|-----------------------|------|
| V _{IN} | Input voltage | -0.3 | 6 | V |
| V _{OUT} | Output voltage | | V _{IN} + 0.3 | V |
| V _{ON} | Input voltage | -0.3 | 6 | V |
| I _{MAX} | Maximum continuous switch current | | 0.5 | A |
| T _A | Operating free-air temperature | -40 | 85 | °C |
| T _J | Maximum junction temperature | | 125 | °C |
| T _{stg} | Storage temperature | -65 | 150 | °C |

- (1) Stresses beyond those listed under absolute maximum ratings may cause permanent damage to the device. These are stress ratings only, and functional operation of the device at these or any other conditions beyond those indicated under *Recommended Operating Conditions* is not implied. Exposure to absolute-maximum-rated conditions for extended periods may affect device reliability.

5.2 ESD Ratings

| | | VALUE | UNIT |
|--------------------|--------------------------------------------------------------------------------|-------|------|
| V _(ESD) | Electrostatic discharge | | |
| | Human body model (HBM), per ANSI/ESDA/JEDEC JS-001 ⁽¹⁾ | 2000 | V |
| | Charged-device model (CDM), per JEDEC specification JESD22-C101 ⁽²⁾ | 1000 | |

- (1) JEDEC document JEP155 states that 500-V HBM allows safe manufacturing with a standard ESD control process.
 (2) JEDEC document JEP157 states that 250-V CDM allows safe manufacturing with a standard ESD control process.

5.3 Recommended Operating Conditions

| | | MIN | MAX | UNIT | |
|------------------|----------------------------------------|------------------------------------|-----------------|------|---|
| V _{IN} | Input voltage | 1.62 | 5.5 | V | |
| V _{OUT} | Output voltage | | V _{IN} | V | |
| V _{IH} | High-level input voltage: ON1, ON2, SR | V _{INx} = 3.0 V to 5.5 V | 1.5 | 5.5 | V |
| | | V _{INx} = 1.62 V to 3.0 V | 1.4 | 5.5 | |
| V _{IL} | Low-level input voltage: ON1, ON2, SR | V _{INx} = 3.0 V to 5.5 V | | 0.5 | V |
| | | V _{INx} = 1.62 V to 3.0 V | | 0.4 | |
| C _{IN} | Input capacitor | 1 ⁽¹⁾ | | μF | |

- (1) See [Section 8.1](#).

5.4 Thermal Information

| THERMAL METRIC ⁽¹⁾ | DCN (SOT) | RSE (UQFN) | UNIT | |
|-------------------------------|----------------------------------------------|------------|------|------|
| | 8 PINS | 8 PINS | | |
| R _{θJA} | Junction-to-ambient thermal resistance | 254 | 124 | °C/W |
| R _{θJC(top)} | Junction-to-case (top) thermal resistance | 122 | 67 | °C/W |
| R _{θJB} | Junction-to-board thermal resistance | 181 | 31.5 | °C/W |
| ψ _{JT} | Junction-to-top characterization parameter | 22 | 2.9 | °C/W |
| ψ _{JB} | Junction-to-board characterization parameter | 178 | 31.5 | °C/W |
| R _{θJC(bot)} | Junction-to-case (bottom) thermal resistance | — | — | °C/W |

- (1) For more information about traditional and new thermal metrics, see *Semiconductor and IC Package Thermal Metrics* (SPRA953).

5.5 Electrical Characteristics

$V_{IN} = 1.62\text{ V to }5.5\text{ V}$, $T_A = -40^\circ\text{C to }85^\circ\text{C}$ (unless otherwise noted)

| PARAMETER | | TEST CONDITIONS | T_A | MIN | TYP ⁽¹⁾ | MAX | UNIT | | | |
|---------------|----------------------------------------|--------------------------------------------------|---------------------------|--------------------------------|-------------------------------------------------------------------|------|------------------|----|------|---------------|
| I_{IN} | Quiescent current (each switch) | $I_{OUTx} = 0$, $V_{INx} = V_{ON}$ | $V_{INx} = 5.5\text{ V}$ | Full | 0.64 | 2 | μA | | | |
| | | | $V_{INx} = 3.3\text{ V}$ | Full | 0.35 | 1.2 | | | | |
| | | | $V_{INx} = 2.5\text{ V}$ | Full | 0.24 | 0.8 | | | | |
| | | | $V_{INx} = 1.8\text{ V}$ | Full | 0.15 | 0.5 | | | | |
| $I_{IN(OFF)}$ | OFF-state supply current (each switch) | $V_{ON} = \text{GND}$, $V_{OUTx} = \text{Open}$ | $V_{INx} = 5.5\text{ V}$ | Full | 0.47 | 3.6 | μA | | | |
| | | | $V_{INx} = 3.3\text{ V}$ | Full | 0.25 | 1.8 | | | | |
| | | | $V_{INx} = 2.5\text{ V}$ | Full | 0.18 | 1.3 | | | | |
| | | | $V_{INx} = 1.8\text{ V}$ | Full | 0.11 | 1.2 | | | | |
| r_{ON} | ON-state resistance (each switch) | $I_{OUT} = -200\text{ mA}$ | $V_{INx} = 5.5\text{ V}$ | 25°C | 342 | 400 | $\text{m}\Omega$ | | | |
| | | | | Full | | 465 | | | | |
| | | | $V_{INx} = 3.3\text{ V}$ | 25°C | 435 | 500 | | | | |
| | | | | Full | | 595 | | | | |
| | | | $V_{INx} = 2.5\text{ V}$ | 25°C | 523 | 620 | | | | |
| | | | | Full | | 720 | | | | |
| | | | $V_{INx} = 1.8\text{ V}$ | 25°C | 737 | 1100 | | | | |
| | | | | Full | | 1300 | | | | |
| | | | $V_{INx} = 1.62\text{ V}$ | 25°C | 848 | 1300 | | | | |
| | | | | Full | | 1500 | | | | |
| | | | r_{PD} | Output pulldown resistance | $V_{IN} = 3.3\text{ V}$, $V_{ON} = 0$, $I_{OUT} = 30\text{ mA}$ | 25°C | | 85 | 120 | Ω |
| | | | I_{ON} | ON-state input leakage current | $V_{ON} = 1.62\text{ V to }5.5\text{ V or GND}$ | Full | | | 0.25 | μA |

(1) Typical values are at $T_A = 25^\circ\text{C}$.

5.6 Switching Characteristics

$V_{IN} = 3.3\text{ V}$, $T_A = 25^\circ\text{C}$, $R_{L_CHIP} = 85\ \Omega$ (unless otherwise noted)

| PARAMETER | | TEST CONDITIONS | MIN | TYP ⁽¹⁾ | MAX | UNIT |
|-----------|---------------------|-----------------------------------------------|-------------------|--------------------|-----|---------------|
| t_{ON} | Turn-ON time | $R_L = 33\ \Omega$, $C_L = 0.1\ \mu\text{F}$ | $SR = V_{IN}$ | 635 | | μs |
| | | | $SR = \text{GND}$ | 67 | | |
| t_{OFF} | Turn-OFF time | $R_L = 33\ \Omega$, $C_L = 0.1\ \mu\text{F}$ | $SR = V_{IN}$ | 4.5 | | μs |
| | | | $SR = \text{GND}$ | 4.2 | | |
| t_r | V_{OUT} rise time | $R_L = 33\ \Omega$, $C_L = 0.1\ \mu\text{F}$ | $SR = V_{IN}$ | 660 | | μs |
| | | | $SR = \text{GND}$ | 75 | | |
| t_f | V_{OUT} fall time | $R_L = 33\ \Omega$, $C_L = 0.1\ \mu\text{F}$ | $SR = V_{IN}$ | 4.5 | | μs |
| | | | $SR = \text{GND}$ | 4.5 | | |

(1) Typical values are at the specified $V_{IN} = 3.3\text{ V}$ and $T_A = 25^\circ\text{C}$.

5.7 Typical DC Characteristics

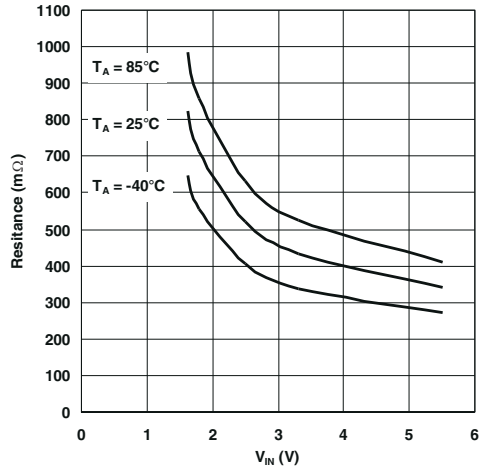

Figure 5-1. ON Resistance vs Input Voltage

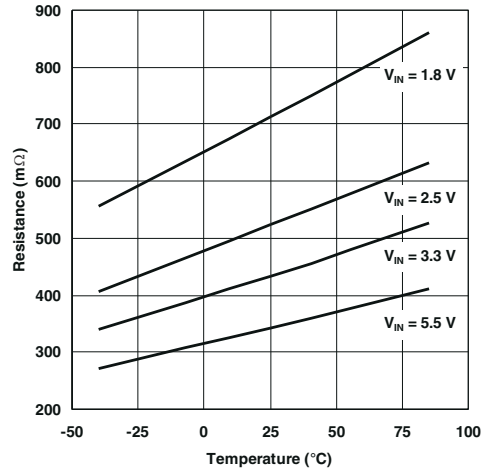

Figure 5-2. ON Resistance vs Temperature

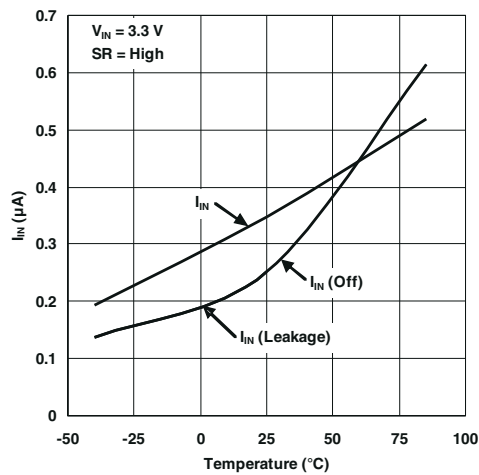

Figure 5-3. Quiescent Current vs Temperature

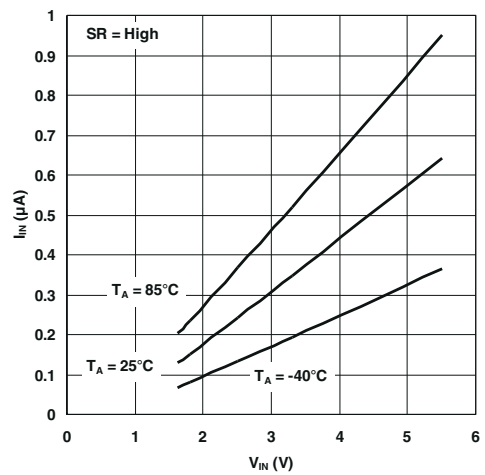

Figure 5-4. Quiescent Current vs Input Voltage

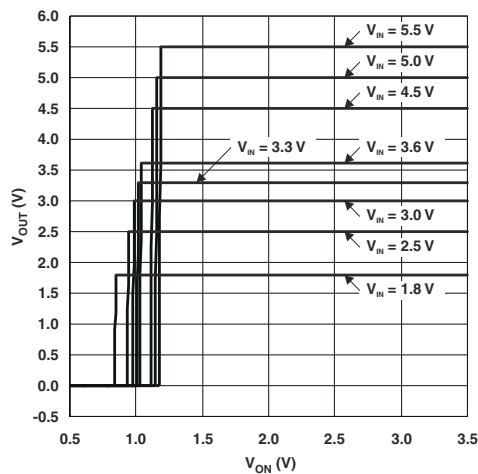

Figure 5-5. ON Threshold

5.8 Typical Switching Characteristics

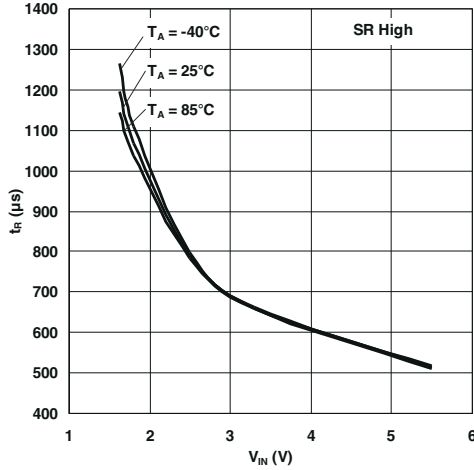

Figure 5-6. Rise Time vs Input Voltage

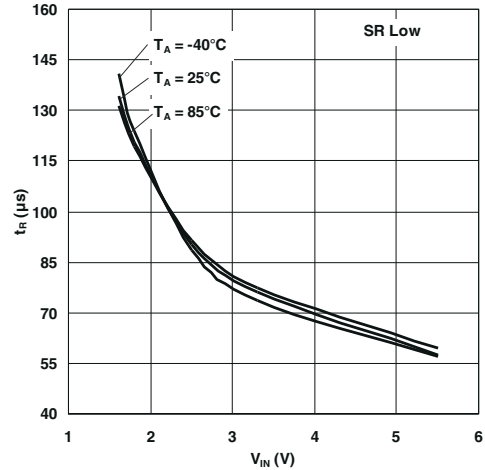

Figure 5-7. Rise Time vs Input Voltage

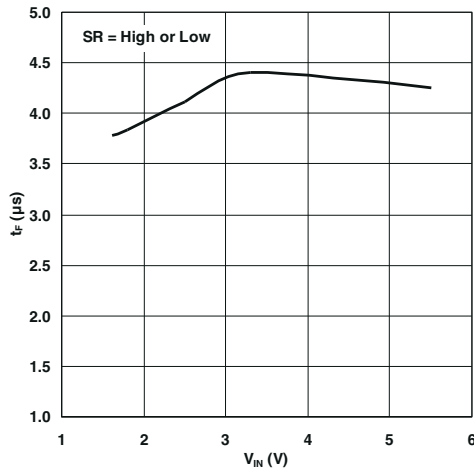

Figure 5-8. Fall Time vs Input Voltage

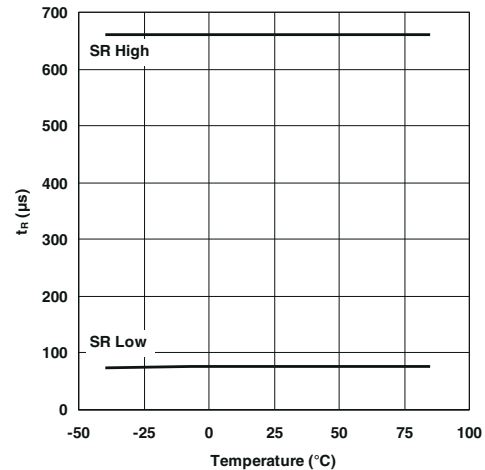

Figure 5-9. Rise Time vs Temperature

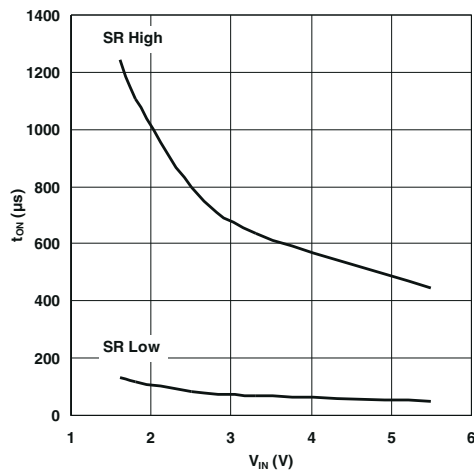

Figure 5-10. On Time vs Input Voltage

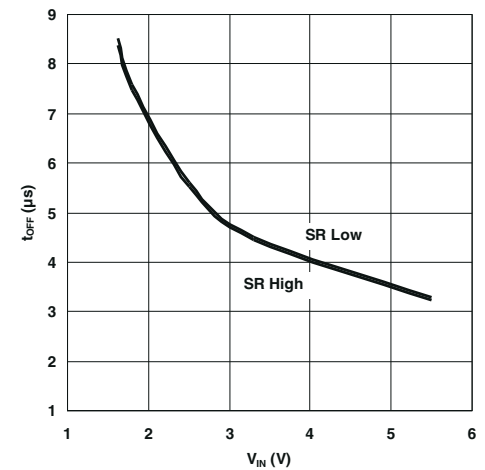
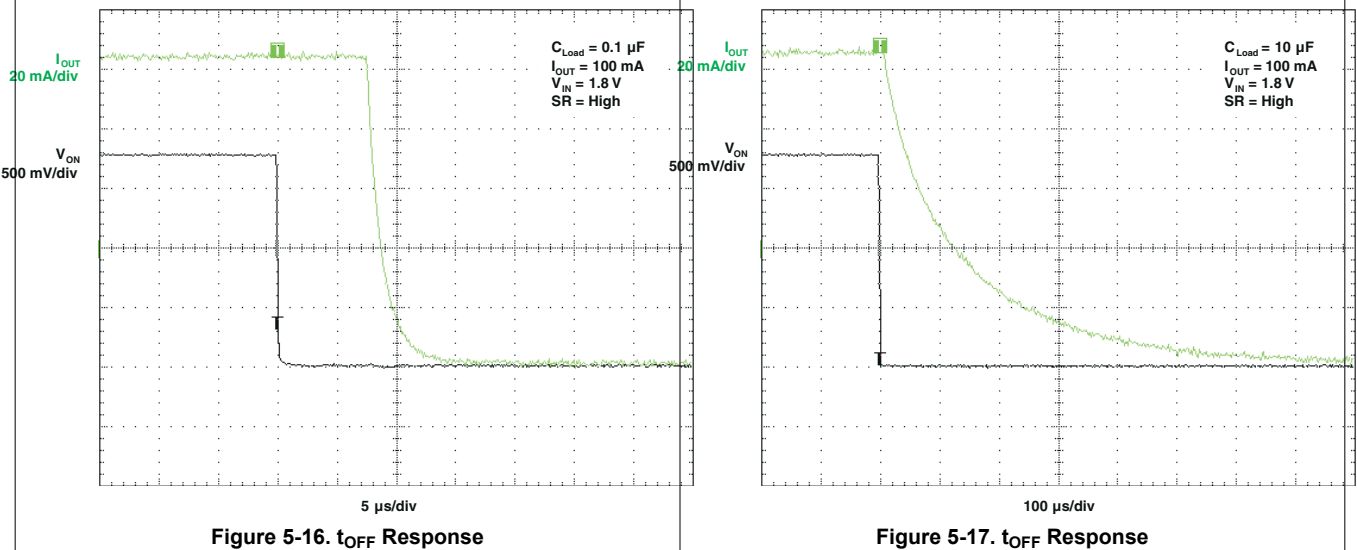
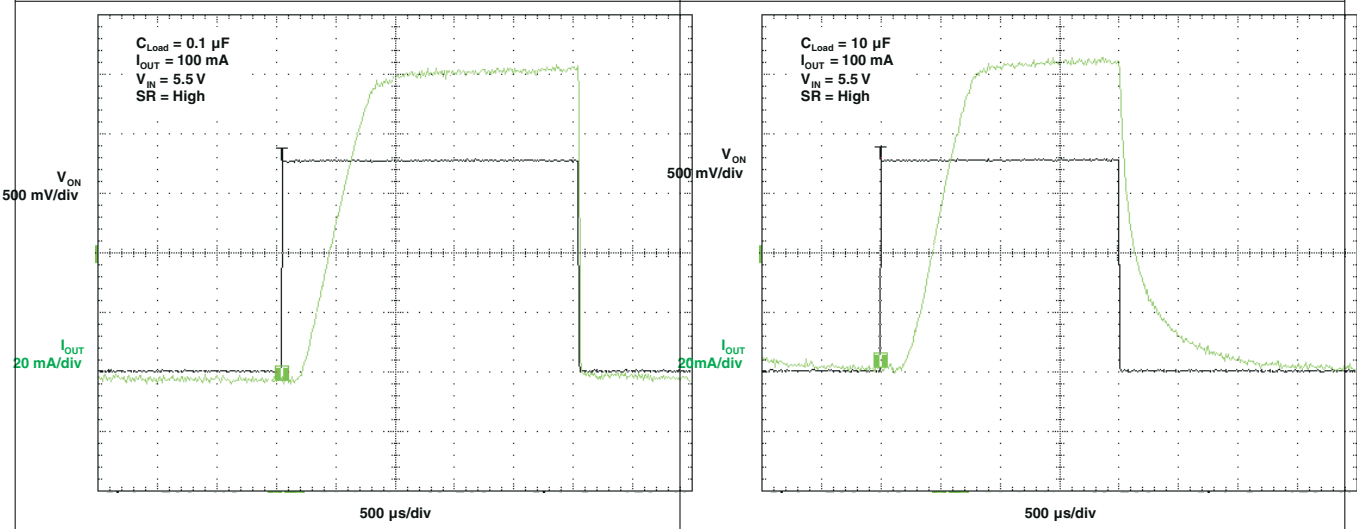
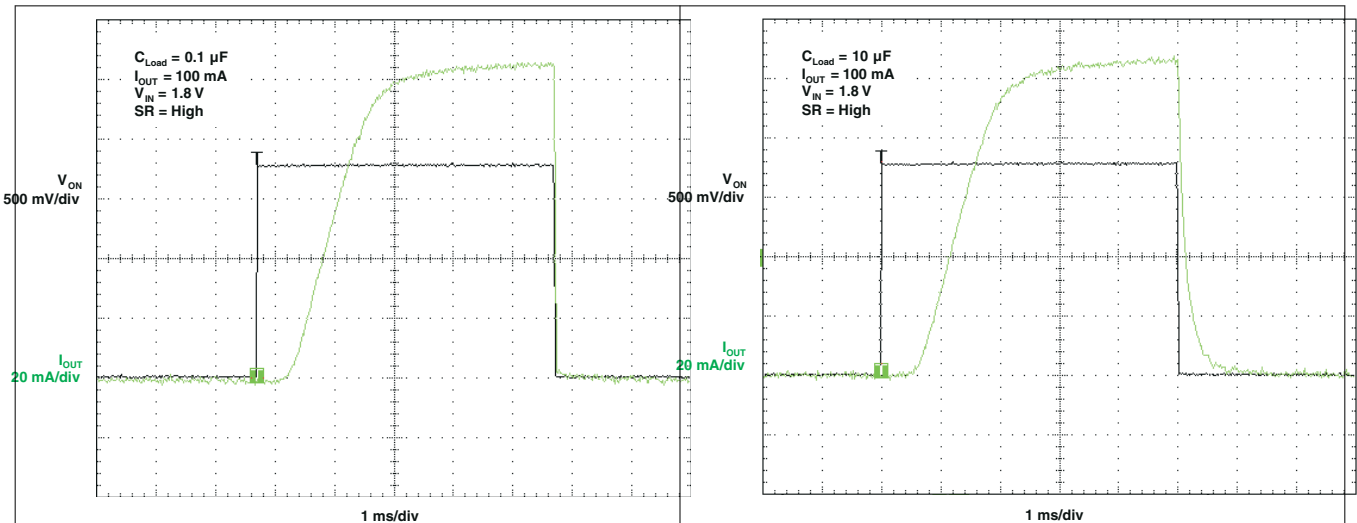

Figure 5-11. Off Time vs Input Voltage

5.8 Typical Switching Characteristics (continued)



5.8 Typical Switching Characteristics (continued)

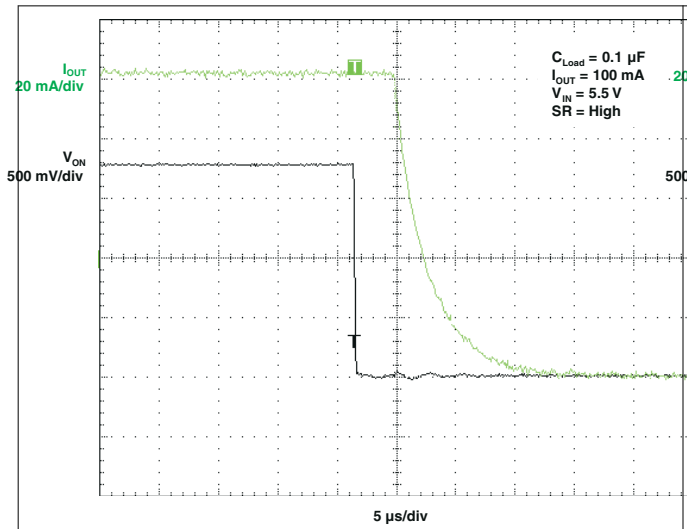

Figure 5-18. t_{OFF} Response

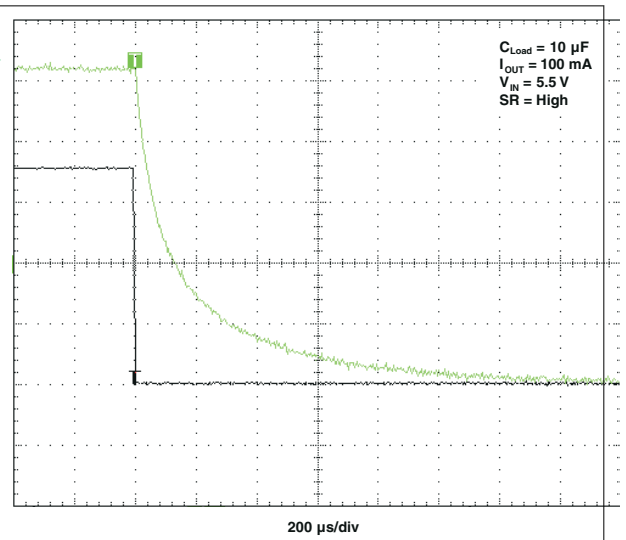

Figure 5-19. t_{OFF} Response

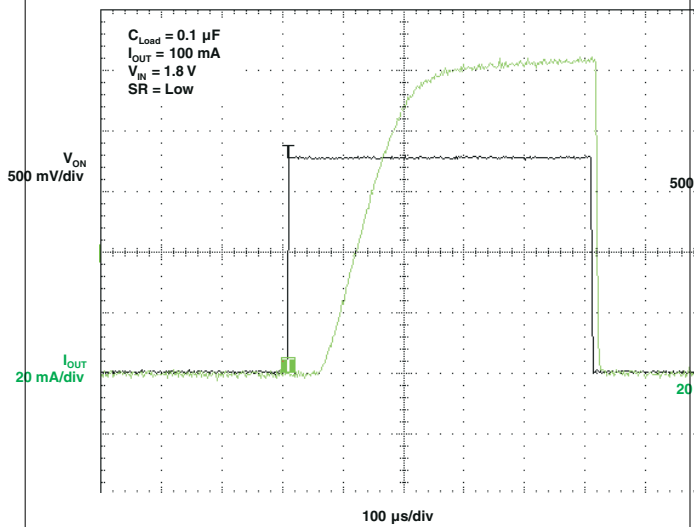

Figure 5-20. t_{ON} Response

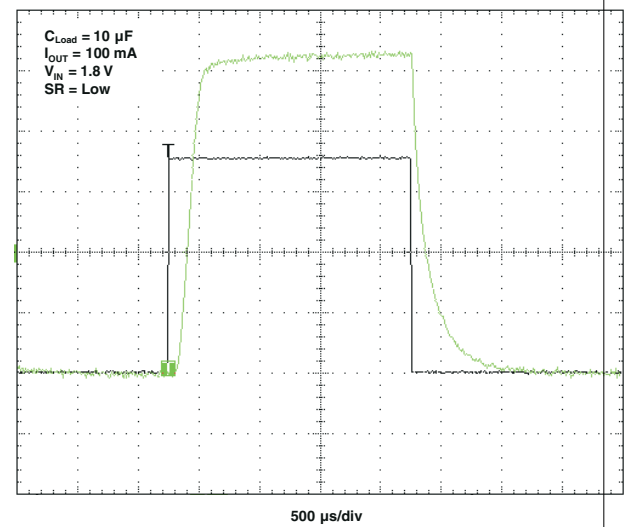

Figure 5-21. t_{ON} Response

5.8 Typical Switching Characteristics (continued)

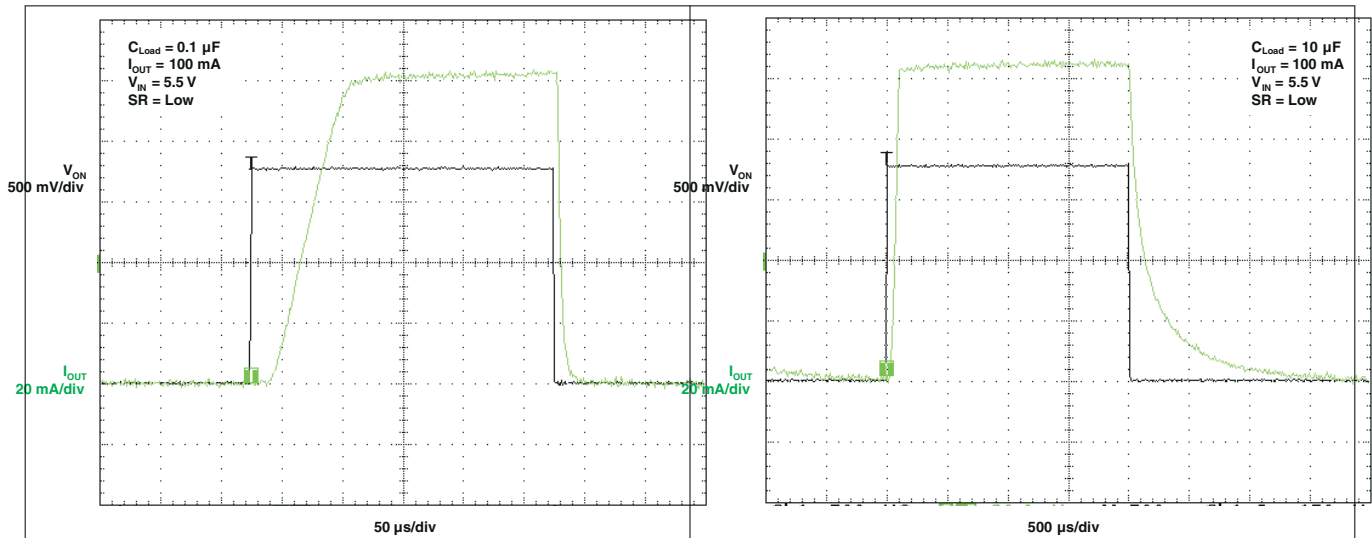

Figure 5-22. t_{ON} Response

Figure 5-23. t_{ON} Response

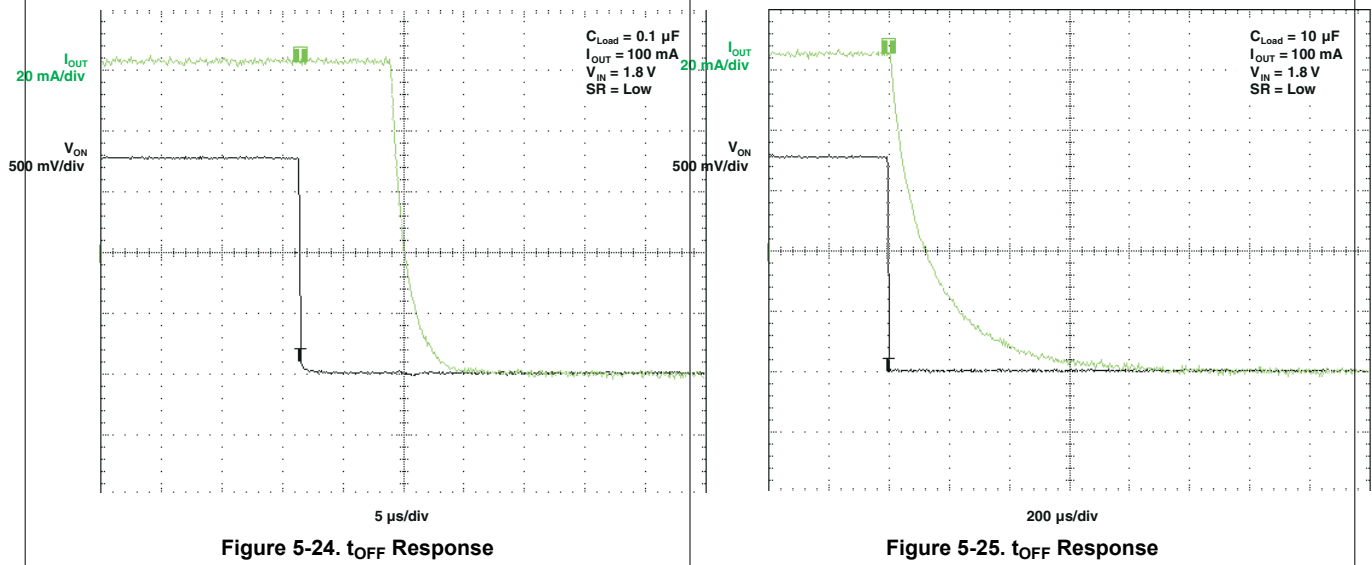
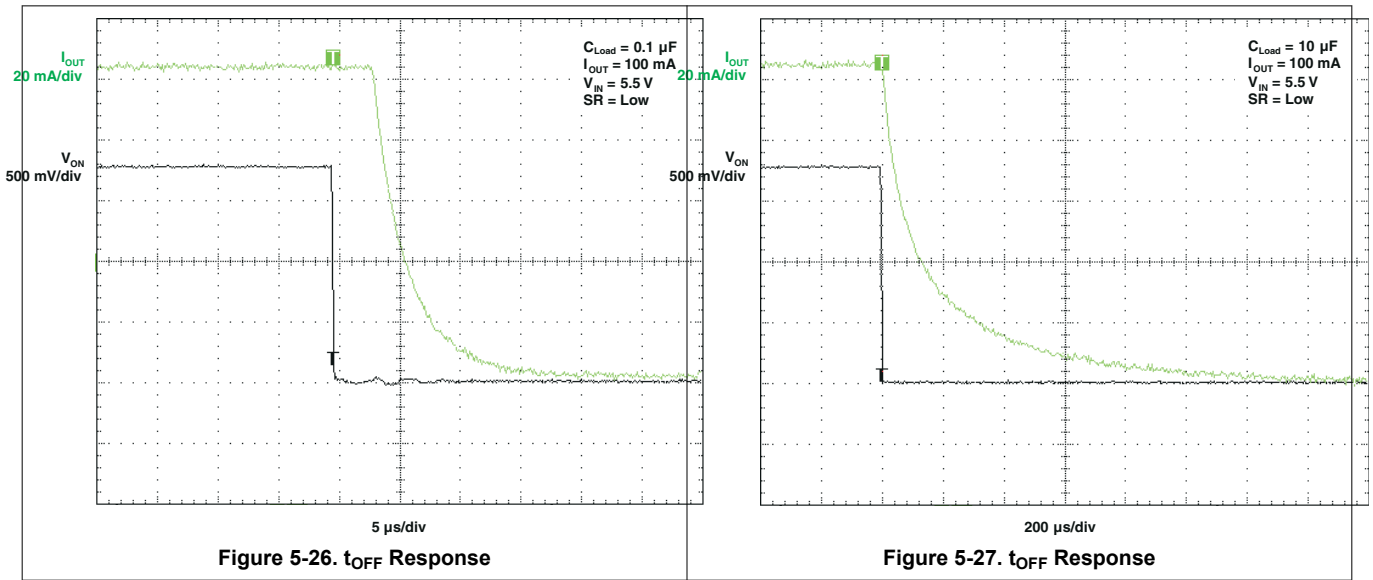

Figure 5-24. t_{OFF} Response

Figure 5-25. t_{OFF} Response

5.8 Typical Switching Characteristics (continued)



6 Parameter Measurement Information

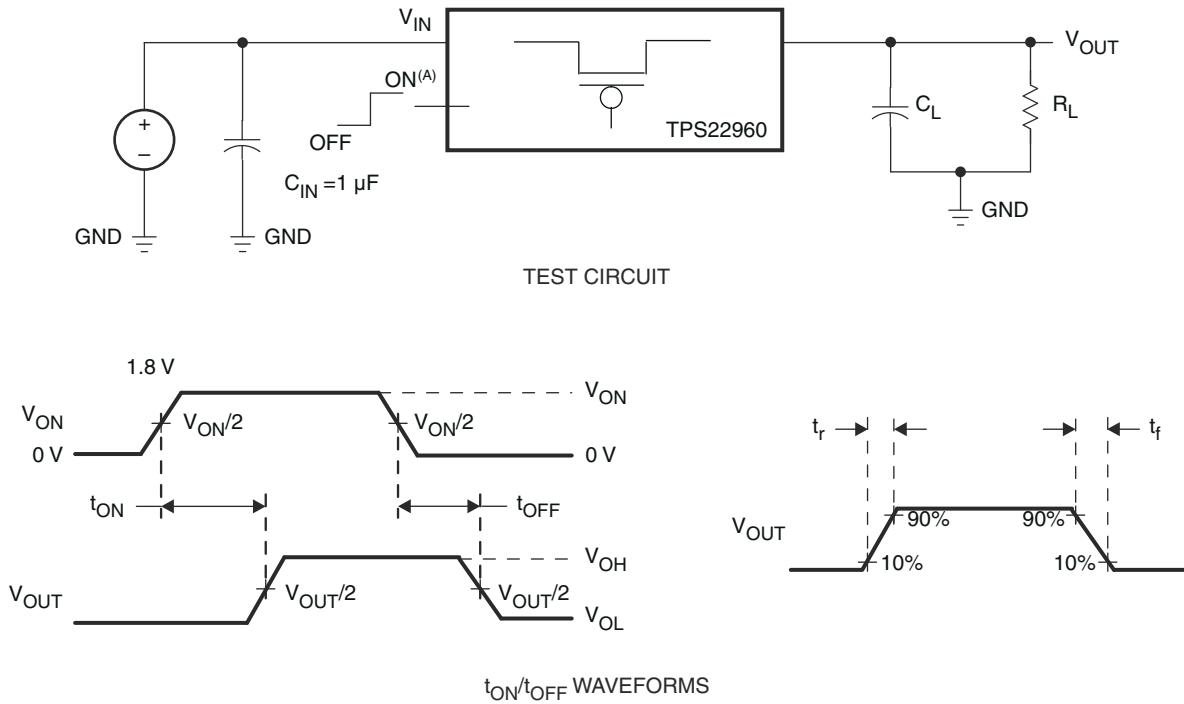

- A. t_{rise} and t_{fall} of the control signal is 100ns.

Figure 6-1. Test Circuit and t_{ON}/t_{OFF} Waveforms

7 Detailed Description

7.1 Overview

The TPS22960 is a dual-channel load switch. The two channels can be independently controlled using the ONx pins. Each channel has an 85-Ω quick discharge resistance from V_{OUTX} to GND when disabled. A single control pin (SR) is used to set the slew rate for both channels..

7.2 Functional Block Diagram

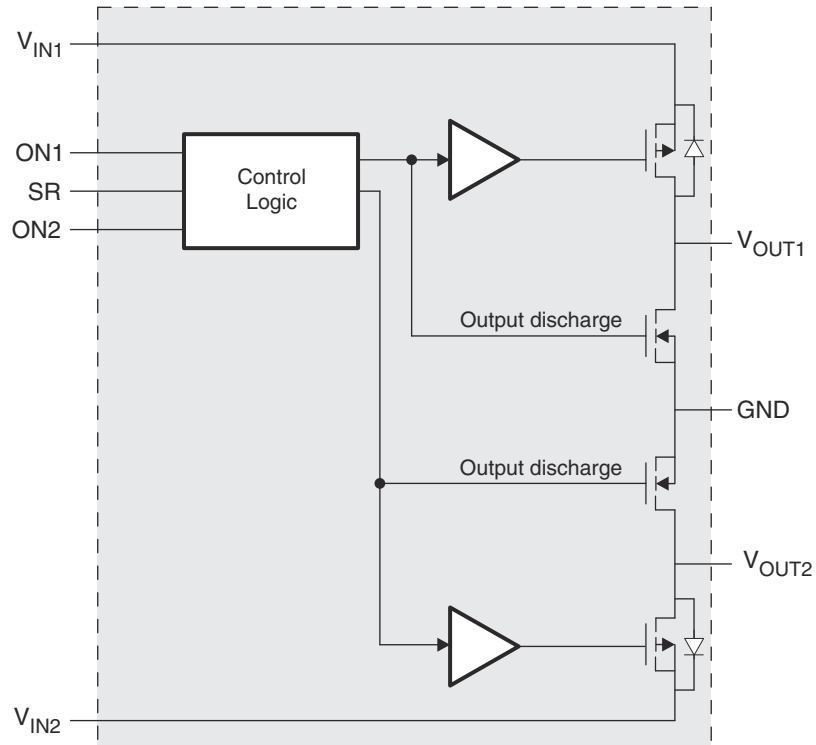

7.3 Feature Description

This section will discuss the features of the TPS22960 which have been summarized in [Table 7-1](#).

Table 7-1. Feature Summary

| DEVICE | r_{ON} AT 3.3 V (TYP) | SLEW RATE AT 3.3 V (TYP) | QUICK OUTPUT DISCHARGE ⁽¹⁾ | MAX OUTPUT CURRENT | ENABLE |
|----------|-------------------------|--------------------------------------------------------|---------------------------------------|--------------------|-------------|
| TPS22960 | 435 m Ω | 75 μ s with SR = low 660 μ s with SR = high | Yes | 500 mA | Active High |

(1) This feature discharges the output of the switch to ground through an 85- Ω resistor, preventing the output from floating.

7.3.1 Output Slew Rate (SR) Control

The slew rate (rise time) of the device is internally controlled in order to avoid inrush current, and it can be slowed down if needed using the SR pin. At 3.3 V, TPS22960 features a 75- μ s rise time with the SR pin tied to ground, and a 660- μ s rise time with the SR pin tied high. Both channels will have the same slew rate set by the SR pin.

7.3.2 Quick Output Discharge (QOD)

Each channel of the TPS22960 includes an independent QOD feature. When the channel is disabled, a discharge resistor is connected between VOUTx and GND. This resistor has a typical value of 85 Ω and prevents the output from floating while the switch is disabled.

7.4 Device Functional Modes

Table 7-2. Configurable Logic Function Table

| ONx | V _{INx} TO V _{OUTx} | V _{OUTx} TO GND |
|-----|---------------------------------------|--------------------------|
| L | OFF | ON |
| H | ON | OFF |

8 Application and Implementation

Note

Information in the following applications sections is not part of the TI component specification, and TI does not warrant its accuracy or completeness. TI's customers are responsible for determining suitability of components for their purposes, as well as validating and testing their design implementation to confirm system functionality.

8.1 Application Information

8.1.1 ON/OFF Control

The ON pin controls the state of the switch. Activating ON continuously holds the switch in the on state, as long as there is no fault. ON is active HI and has a low threshold, making it capable of interfacing with low voltage signals. The ON pin is compatible with standard GPIO logic threshold. It can be used with any microcontroller with 1.2-V, 1.8-V, 2.5-V, or 3.3-V GPIOs.

8.1.2 Input Capacitor

To limit voltage drop or voltage transients, sufficient capacitance needs to be placed on the input side of the load switch (from V_{IN} to GND). In most cases, a 1- μ F ceramic capacitor, C_{IN} , placed close to the pins is usually sufficient. However, when switching heavy capacitive loads, higher values of C_{IN} may be needed to prevent the system supply voltage from dropping.

8.1.3 Output Capacitor

The integral body diode in the PMOS switch will allow reverse current flow if V_{OUT} exceeds V_{IN} . A C_L greater than C_{IN} can cause V_{OUT} to exceed V_{IN} if the system supply is removed. In the case where the system supply could be removed and reverse current is a concern, a C_{IN} greater than C_L is recommended.

8.2 Typical Application

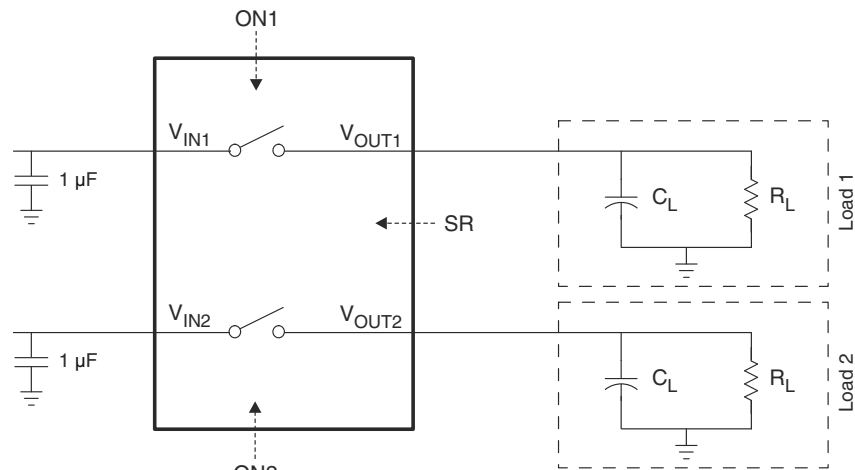

Figure 8-1. Typical Application Schematic

8.2.1 Design Requirements

For this design example, use input parameters in [Table 8-1](#).

Table 8-1. Design Parameters

| PARAMETER | EXAMPLE VALUE |
|-----------------------------------|---------------|
| V _{IN} | 3.3 V |
| C _L | 22 μF |
| Maximum acceptable inrush current | 200 mA |

8.2.2 Detailed Design Procedure

8.2.2.1 Inrush Current

When the switch is enabled, the output capacitors must be charged up from 0 V to the set value (in this example, 3.3 V). This charge arrives in the form of inrush current. Inrush current can be calculated using the following equation:

$$\text{Inrush Current} = C \times dV / dt \tag{1}$$

Where:

C = output capacitance

dV = output voltage

dt = rise time

The TPS22960 offers selectable rise time control for V_{OUT}. This feature allows the user to control the inrush current during turnon. [Equation 1](#) can be used to find the required rise time to limit the inrush current to the design requirements

$$200 \text{ mA} = 22 \text{ } \mu\text{F} \times (3.3 \text{ V} \times 80\%) / dt \tag{2}$$

$$dt = 290 \text{ } \mu\text{s} \tag{4}$$

To ensure an inrush current of less than 200 mA, SR must be set high for a rise time greater than 290 μs. The following application curves show the different inrush for each SR setting in this design example.

8.2.3 Application Curves

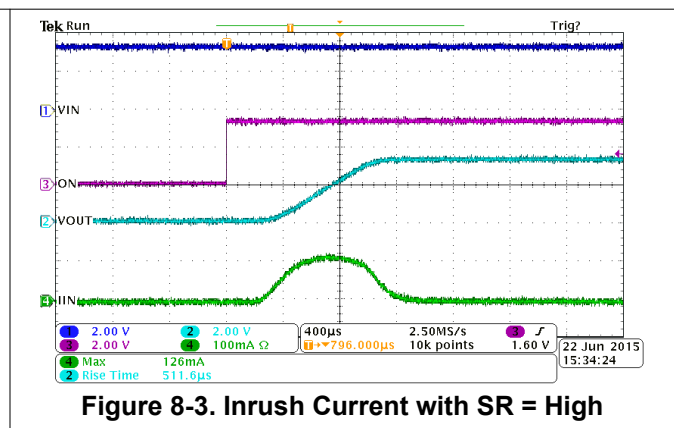
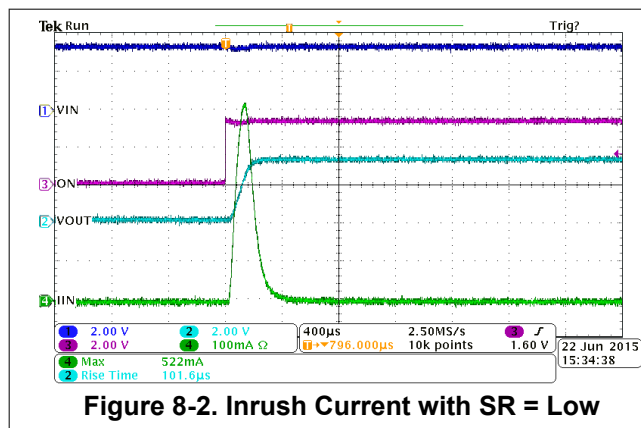

8.3 Power Supply Recommendations

The device is designed to operate from an input voltage range of 1.62 V to 5.5 V. The power supply should be well-regulated and placed as close to the device terminals as possible. It must be able to withstand all transient

and load current steps. In most situations, using an input capacitance of 1 μF is sufficient to prevent the supply voltage from dipping when the switch is turned on. In cases where the power supply is slow to respond to a large transient current or large load current step, additional bulk capacitance may be required on the input

The requirements for larger input capacitance can be mitigated by selecting the slower slew rate +SR=high. This will cause the load switch to turn on more slowly and limit the inrush current.

8.4 Layout

8.4.1 Layout Guidelines

For best performance, all traces should be as short as possible. To be most effective, the input and output capacitors should be placed close to the device to minimize the effects that parasitic trace inductances may have on normal and short-circuit operation. Using wide traces for V_{IN} , V_{OUT} , and GND will help minimize the parasitic electrical effects along with minimizing the case to ambient thermal impedance.

8.4.2 Layout Example

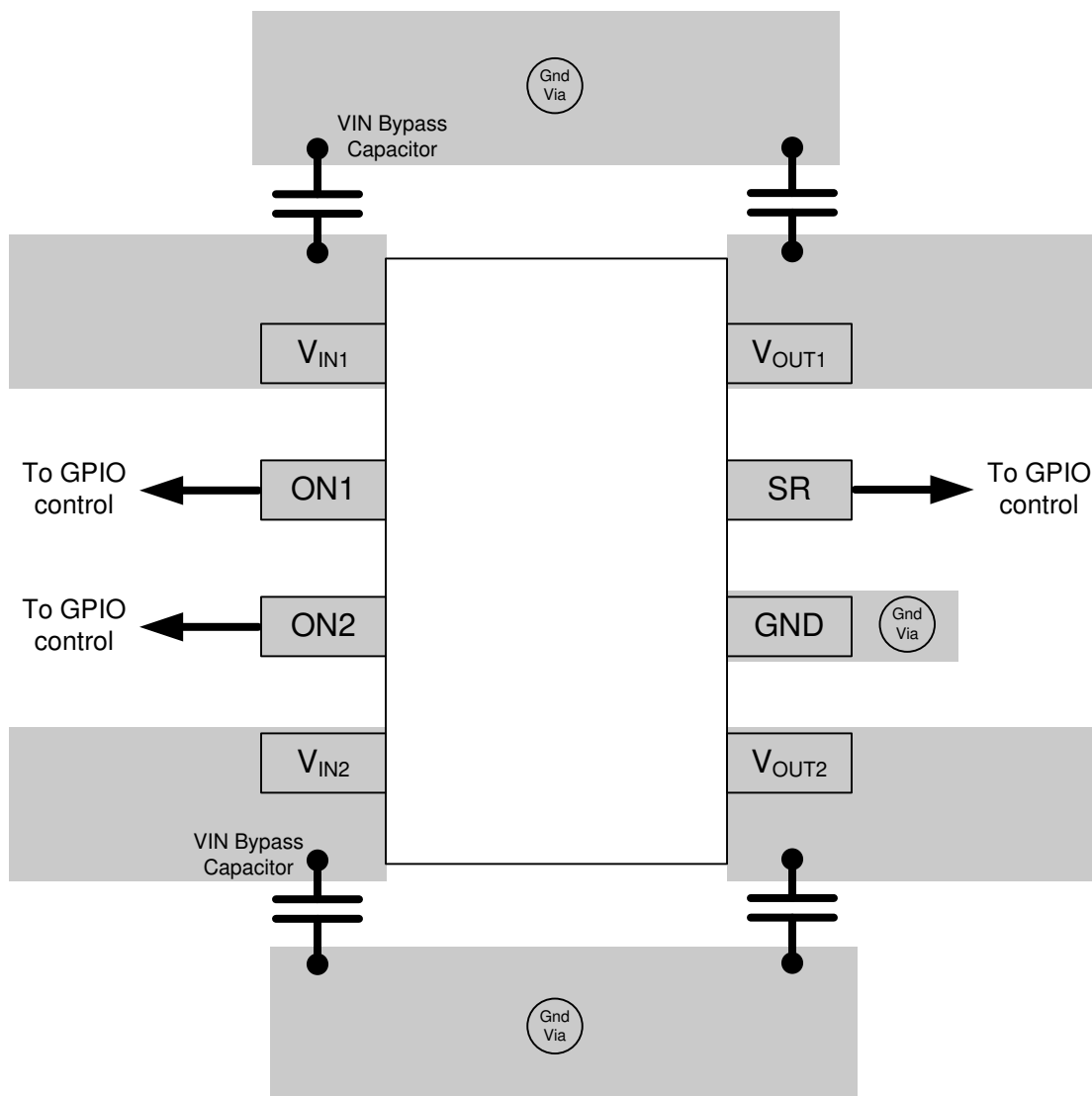

Figure 8-4. DCN Package Layout

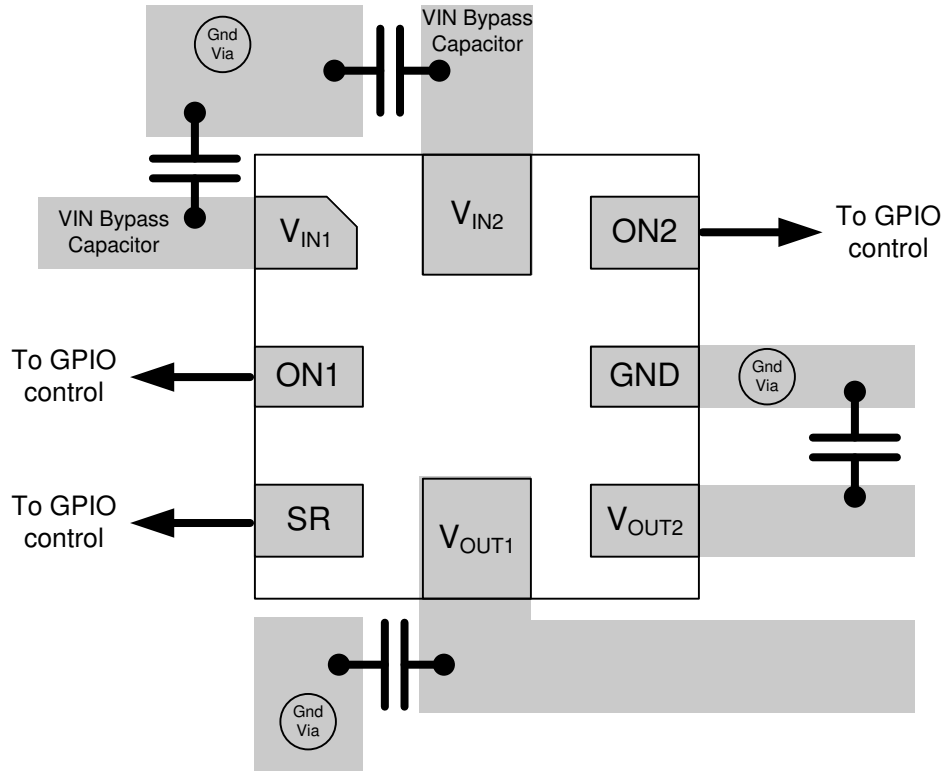

Figure 8-5. RSE Package Layout

9 Device and Documentation Support

9.1 Receiving Notification of Documentation Updates

To receive notification of documentation updates, navigate to the device product folder on ti.com. Click on *Notifications* to register and receive a weekly digest of any product information that has changed. For change details, review the revision history included in any revised document.

9.2 Support Resources

[TI E2E™ support forums](#) are an engineer's go-to source for fast, verified answers and design help — straight from the experts. Search existing answers or ask your own question to get the quick design help you need.

Linked content is provided "AS IS" by the respective contributors. They do not constitute TI specifications and do not necessarily reflect TI's views; see TI's [Terms of Use](#).

9.3 Trademarks

TI E2E™ is a trademark of Texas Instruments.
All trademarks are the property of their respective owners.

9.4 Electrostatic Discharge Caution



This integrated circuit can be damaged by ESD. Texas Instruments recommends that all integrated circuits be handled with appropriate precautions. Failure to observe proper handling and installation procedures can cause damage.

ESD damage can range from subtle performance degradation to complete device failure. Precision integrated circuits may be more susceptible to damage because very small parametric changes could cause the device not to meet its published specifications.

9.5 Glossary

[TI Glossary](#) This glossary lists and explains terms, acronyms, and definitions.

10 Revision History

NOTE: Page numbers for previous revisions may differ from page numbers in the current version.

| Changes from Revision D (February 2016) to Revision E (April 2024) | Page |
|----------------------------------------------------------------------------------------------------------------------------------------|-------------|
| • Updated the numbering format for tables, figures, and cross-references throughout the document..... | 1 |
| • Changed maximum $I_{IN(OFF)}$ at $V_{IN}=1.8V$ from $0.9\mu A$: to $1.2\mu A$ in the <i>Electrical Characteristics</i> section..... | 4 |

| Changes from Revision C (July 2015) to Revision D (February 2016) | Page |
|--------------------------------------------------------------------------|-------------|
| • Made changes to Section 8.1 | 1 |

11 Mechanical, Packaging, and Orderable Information

The following pages include mechanical, packaging, and orderable information. This information is the most current data available for the designated devices. This data is subject to change without notice and revision of this document. For browser-based versions of this data sheet, refer to the left-hand navigation.

PACKAGING INFORMATION

| Orderable part number | Status (1) | Material type (2) | Package Pins | Package qty Carrier | RoHS (3) | Lead finish/ Ball material (4) | MSL rating/ Peak reflow (5) | Op temp (°C) | Part marking (6) |
|------------------------------|---------------|----------------------|------------------|-----------------------|-------------|--------------------------------------|-----------------------------------|--------------|---------------------|
| TPS22960DCNR | Active | Production | SOT-23 (DCN) 8 | 3000 LARGE T&R | Yes | NIPDAU | Level-1-260C-UNLIM | -40 to 85 | (NFRO, NFRR) |
| TPS22960DCNR.A | Active | Production | SOT-23 (DCN) 8 | 3000 LARGE T&R | Yes | NIPDAU | Level-1-260C-UNLIM | -40 to 85 | (NFRO, NFRR) |
| TPS22960DCNR.B | Active | Production | SOT-23 (DCN) 8 | 3000 LARGE T&R | Yes | NIPDAU | Level-1-260C-UNLIM | -40 to 85 | (NFRO, NFRR) |
| TPS22960DCNRG4 | Active | Production | SOT-23 (DCN) 8 | 3000 LARGE T&R | Yes | NIPDAU | Level-1-260C-UNLIM | -40 to 85 | NFRR |
| TPS22960DCNRG4.A | Active | Production | SOT-23 (DCN) 8 | 3000 LARGE T&R | Yes | NIPDAU | Level-1-260C-UNLIM | -40 to 85 | NFRR |
| TPS22960DCNRG4.B | Active | Production | SOT-23 (DCN) 8 | 3000 LARGE T&R | Yes | NIPDAU | Level-1-260C-UNLIM | -40 to 85 | NFRR |
| TPS22960RSER | Active | Production | UQFN (RSE) 8 | 3000 LARGE T&R | Yes | NIPDAUAG | Level-1-260C-UNLIM | -40 to 85 | 72 |
| TPS22960RSER.A | Active | Production | UQFN (RSE) 8 | 3000 LARGE T&R | Yes | NIPDAUAG | Level-1-260C-UNLIM | -40 to 85 | 72 |
| TPS22960RSER.B | Active | Production | UQFN (RSE) 8 | 3000 LARGE T&R | Yes | NIPDAUAG | Level-1-260C-UNLIM | -40 to 85 | 72 |
| TPS22960RSET | Active | Production | UQFN (RSE) 8 | 250 SMALL T&R | Yes | NIPDAUAG | Level-1-260C-UNLIM | -40 to 85 | 72 |
| TPS22960RSET.A | Active | Production | UQFN (RSE) 8 | 250 SMALL T&R | Yes | NIPDAUAG | Level-1-260C-UNLIM | -40 to 85 | 72 |
| TPS22960RSET.B | Active | Production | UQFN (RSE) 8 | 250 SMALL T&R | Yes | NIPDAUAG | Level-1-260C-UNLIM | -40 to 85 | 72 |

(1) **Status:** For more details on status, see our [product life cycle](#).

(2) **Material type:** When designated, preproduction parts are prototypes/experimental devices, and are not yet approved or released for full production. Testing and final process, including without limitation quality assurance, reliability performance testing, and/or process qualification, may not yet be complete, and this item is subject to further changes or possible discontinuation. If available for ordering, purchases will be subject to an additional waiver at checkout, and are intended for early internal evaluation purposes only. These items are sold without warranties of any kind.

(3) **RoHS values:** Yes, No, RoHS Exempt. See the [TI RoHS Statement](#) for additional information and value definition.

(4) **Lead finish/Ball material:** Parts may have multiple material finish options. Finish options are separated by a vertical ruled line. Lead finish/Ball material values may wrap to two lines if the finish value exceeds the maximum column width.

(5) **MSL rating/Peak reflow:** The moisture sensitivity level ratings and peak solder (reflow) temperatures. In the event that a part has multiple moisture sensitivity ratings, only the lowest level per JEDEC standards is shown. Refer to the shipping label for the actual reflow temperature that will be used to mount the part to the printed circuit board.

(6) **Part marking:** There may be an additional marking, which relates to the logo, the lot trace code information, or the environmental category of the part.

Multiple part markings will be inside parentheses. Only one part marking contained in parentheses and separated by a "-" will appear on a part. If a line is indented then it is a continuation of the previous line and the two combined represent the entire part marking for that device.

Important Information and Disclaimer: The information provided on this page represents TI's knowledge and belief as of the date that it is provided. TI bases its knowledge and belief on information provided by third parties, and makes no representation or warranty as to the accuracy of such information. Efforts are underway to better integrate information from third parties. TI has taken and continues to take reasonable steps to provide representative and accurate information but may not have conducted destructive testing or chemical analysis on incoming materials and chemicals. TI and TI suppliers consider certain information to be proprietary, and thus CAS numbers and other limited information may not be available for release.

In no event shall TI's liability arising out of such information exceed the total purchase price of the TI part(s) at issue in this document sold by TI to Customer on an annual basis.

TAPE AND REEL INFORMATION

QUADRANT ASSIGNMENTS FOR PIN 1 ORIENTATION IN TAPE

*All dimensions are nominal

| Device | Package Type | Package Drawing | Pins | SPQ | Reel Diameter (mm) | Reel Width W1 (mm) | A0 (mm) | B0 (mm) | K0 (mm) | P1 (mm) | W (mm) | Pin1 Quadrant |
|----------------|--------------|-----------------|------|------|--------------------|--------------------|---------|---------|---------|---------|--------|---------------|
| TPS22960DCNR | SOT-23 | DCN | 8 | 3000 | 179.0 | 8.4 | 3.2 | 3.2 | 1.4 | 4.0 | 8.0 | Q3 |
| TPS22960DCNR | SOT-23 | DCN | 8 | 3000 | 180.0 | 8.4 | 3.23 | 3.17 | 1.37 | 4.0 | 8.0 | Q3 |
| TPS22960DCNRG4 | SOT-23 | DCN | 8 | 3000 | 180.0 | 8.4 | 3.23 | 3.17 | 1.37 | 4.0 | 8.0 | Q3 |
| TPS22960RSER | UQFN | RSE | 8 | 3000 | 180.0 | 8.4 | 1.7 | 1.7 | 0.7 | 4.0 | 8.0 | Q2 |
| TPS22960RSET | UQFN | RSE | 8 | 250 | 180.0 | 8.4 | 1.6 | 1.6 | 0.66 | 4.0 | 8.0 | Q2 |

TAPE AND REEL BOX DIMENSIONS

*All dimensions are nominal

| Device | Package Type | Package Drawing | Pins | SPQ | Length (mm) | Width (mm) | Height (mm) |
|----------------|--------------|-----------------|------|------|-------------|------------|-------------|
| TPS22960DCNR | SOT-23 | DCN | 8 | 3000 | 203.0 | 203.0 | 35.0 |
| TPS22960DCNR | SOT-23 | DCN | 8 | 3000 | 183.0 | 183.0 | 20.0 |
| TPS22960DCNRG4 | SOT-23 | DCN | 8 | 3000 | 183.0 | 183.0 | 20.0 |
| TPS22960RSER | UQFN | RSE | 8 | 3000 | 183.0 | 183.0 | 20.0 |
| TPS22960RSET | UQFN | RSE | 8 | 250 | 183.0 | 183.0 | 20.0 |

DCN (R-PDSO-G8)

PLASTIC SMALL-OUTLINE PACKAGE (DIE DOWN)

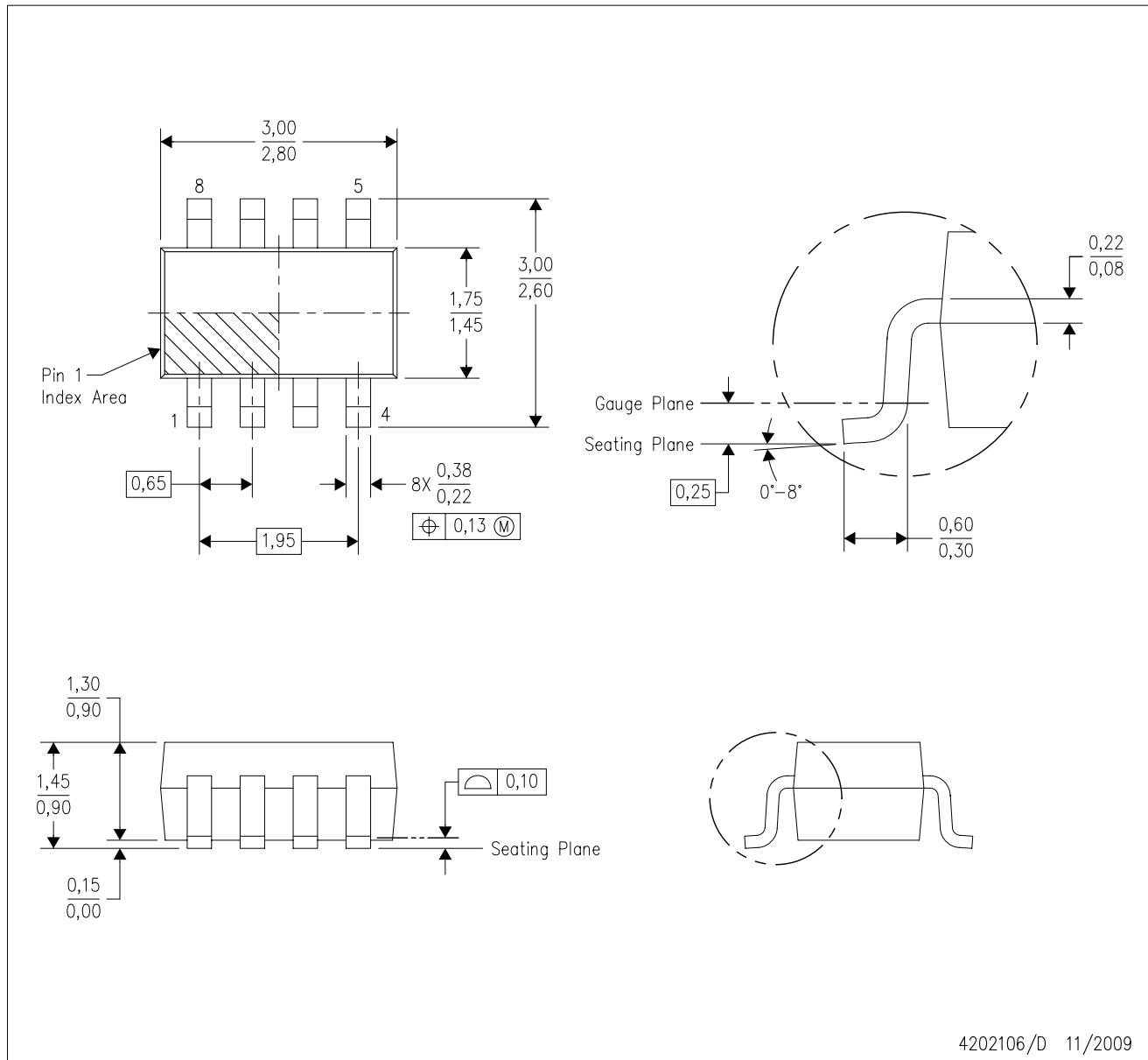

- NOTES:
- A. All linear dimensions are in millimeters.
 - B. This drawing is subject to change without notice.
 - C. Package outline exclusive of metal burr & dambar protrusion/intrusion.
 - D. Package outline inclusive of solder plating.
 - E. A visual index feature must be located within the Pin 1 index area.
 - F. Falls within JEDEC MO-178 Variation BA.
 - G. Body dimensions do not include flash or protrusion. Mold flash and protrusion shall not exceed 0.25 per side.

DCN (R-PDSO-G8)

PLASTIC SMALL-OUTLINE PACKAGE (DIE DOWN)



- NOTES:
- A. All linear dimensions are in millimeters.
 - B. This drawing is subject to change without notice.
 - C. Publication IPC-7351 is recommended for alternate designs.
 - D. Laser cutting apertures with trapezoidal walls and also rounding corners will offer better paste release. Customers should contact their board assembly site for stencil design recommendations. Refer to IPC-7525.
 - E. Customers should contact their board fabrication site for solder mask tolerances between and around signal pads.

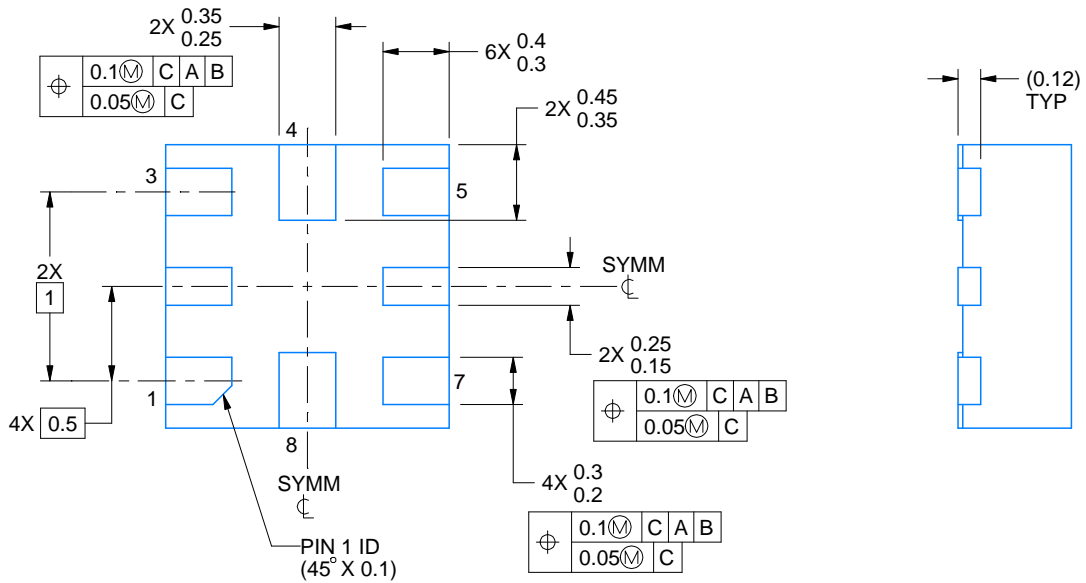
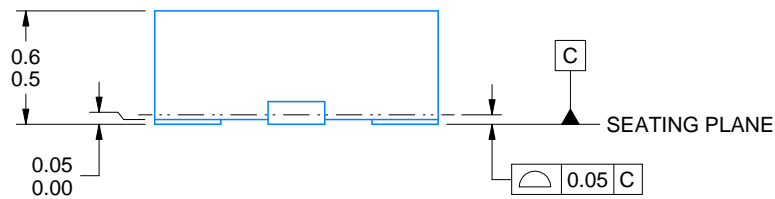
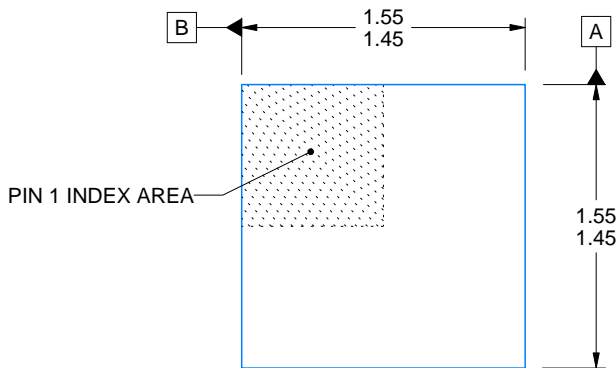
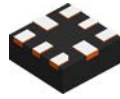

4220323/B 03/2018

NOTES:

1. All linear dimensions are in millimeters. Any dimensions in parenthesis are for reference only. Dimensioning and tolerancing per ASME Y14.5M.
2. This drawing is subject to change without notice.

EXAMPLE BOARD LAYOUT

RSE0008A

UQFN - 0.6 mm max height

PLASTIC QUAD FLATPACK - NO LEAD

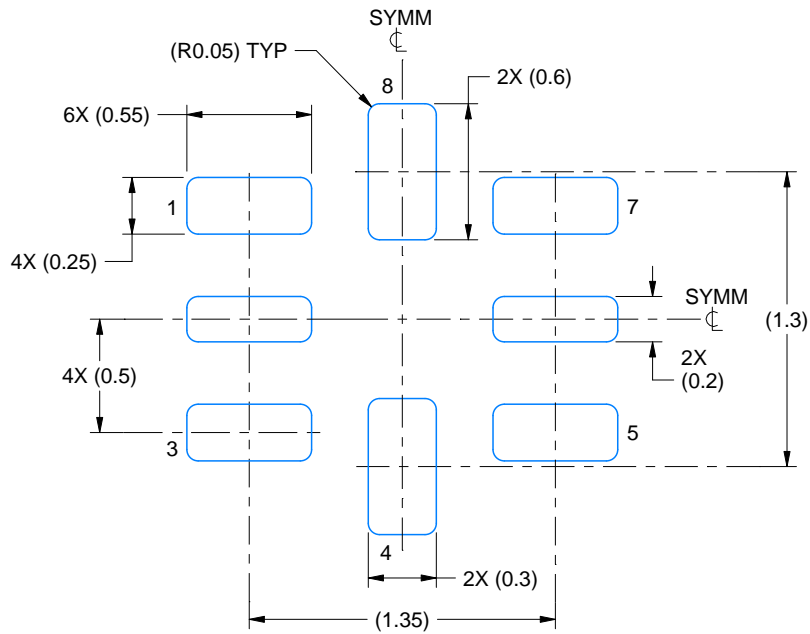

LAND PATTERN EXAMPLE
SCALE:30X

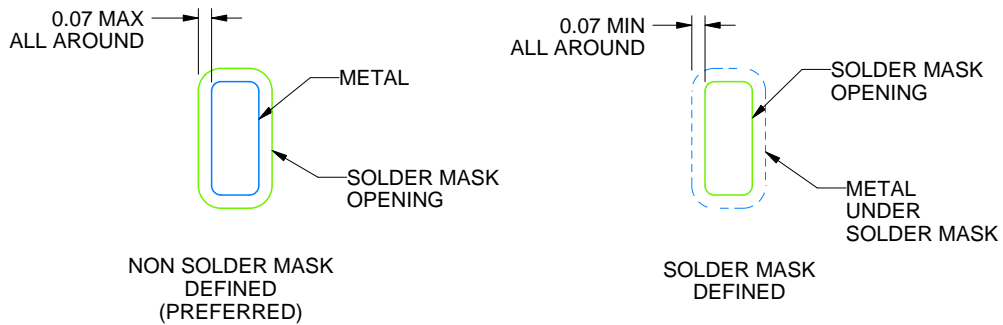

SOLDER MASK DETAILS
NOT TO SCALE

4220323/B 03/2018

NOTES: (continued)

3. For more information, see Texas Instruments literature number SLUA271 (www.ti.com/lit/slua271).

EXAMPLE STENCIL DESIGN

RSE0008A

UQFN - 0.6 mm max height

PLASTIC QUAD FLATPACK - NO LEAD

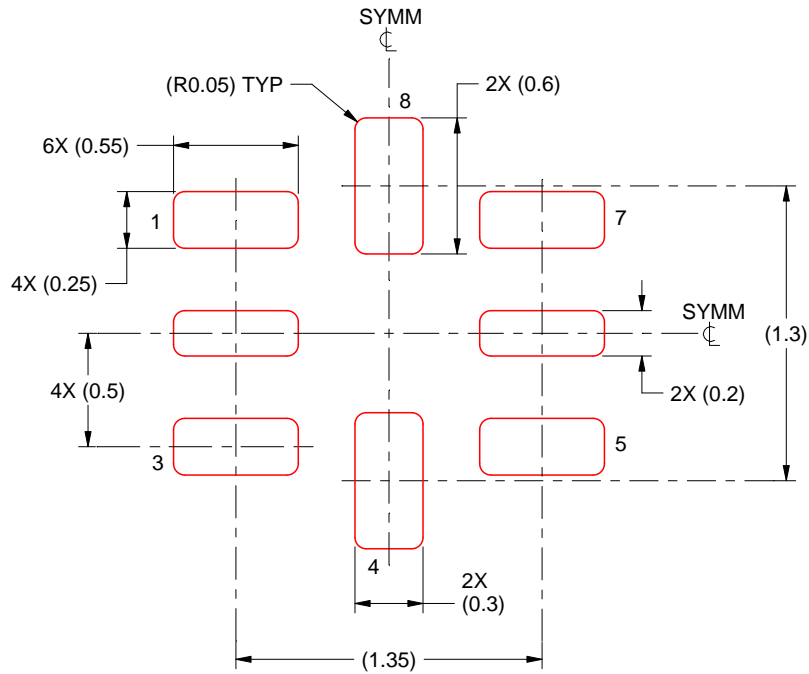

SOLDER PASTE EXAMPLE
BASED ON 0.1 mm THICKNESS
SCALE: 30X

4220323/B 03/2018

NOTES: (continued)

5. Laser cutting apertures with trapezoidal walls and rounded corners may offer better paste release. IPC-7525 may have alternate design recommendations.

IMPORTANT NOTICE AND DISCLAIMER

TI PROVIDES TECHNICAL AND RELIABILITY DATA (INCLUDING DATASHEETS), DESIGN RESOURCES (INCLUDING REFERENCE DESIGNS), APPLICATION OR OTHER DESIGN ADVICE, WEB TOOLS, SAFETY INFORMATION, AND OTHER RESOURCES "AS IS" AND WITH ALL FAULTS, AND DISCLAIMS ALL WARRANTIES, EXPRESS AND IMPLIED, INCLUDING WITHOUT LIMITATION ANY IMPLIED WARRANTIES OF MERCHANTABILITY, FITNESS FOR A PARTICULAR PURPOSE OR NON-INFRINGEMENT OF THIRD PARTY INTELLECTUAL PROPERTY RIGHTS.

These resources are intended for skilled developers designing with TI products. You are solely responsible for (1) selecting the appropriate TI products for your application, (2) designing, validating and testing your application, and (3) ensuring your application meets applicable standards, and any other safety, security, regulatory or other requirements.

These resources are subject to change without notice. TI grants you permission to use these resources only for development of an application that uses the TI products described in the resource. Other reproduction and display of these resources is prohibited. No license is granted to any other TI intellectual property right or to any third party intellectual property right. TI disclaims responsibility for, and you fully indemnify TI and its representatives against any claims, damages, costs, losses, and liabilities arising out of your use of these resources.

TI's products are provided subject to [TI's Terms of Sale](#), [TI's General Quality Guidelines](#), or other applicable terms available either on ti.com or provided in conjunction with such TI products. TI's provision of these resources does not expand or otherwise alter TI's applicable warranties or warranty disclaimers for TI products. Unless TI explicitly designates a product as custom or customer-specified, TI products are standard, catalog, general purpose devices.

TI objects to and rejects any additional or different terms you may propose.

Copyright © 2026, Texas Instruments Incorporated

Last updated 10/2025