

TPS26742E-Q1 Automotive Dual-Port USB Type-C® PD Controller with 240W EPR

1 Features

- AEC-Q100 test guidance with the following:
 - Device temperature grade 1: -40°C to 125°C ambient operating temperature range
 - Device HBM ESD classification level:
 - Level 2 and level 3A
 - Device CDM ESD classification level:
 - Level C2a and C2b
- TPS26742E-Q1 is a fully configurable dual-port PD3.2 source controller.
 - Extended power range (EPR) support
 - 40V tolerant VBUS
 - 24V tolerant CC and DP/DM pins
 - GUI tool to easily configure for various applications
 - Programmable power supply (PPS) support (source)
- USB Type-C power delivery (PD) controller
 - USB PD R3.2 compliant
 - USB Type-C R2.4 compliant
 - 20 configurable GPIOs
 - Cable attach and orientation detection
 - Integrated VCONN switch. No external supply required to read eMarker
 - Physical layer and policy engine
 - Integrated LDO with input up to 40V
 - One I²C controller port (I2C2)
 - Two I²C target ports (I2C1, I2C3)
 - UART and LIN support
 - Closed-chassis debugging
- Integrated flash memory supporting updates via I²C gated by an authentication check
 - Closed-chassis flash updates via I2C4
- System power management
 - Across multiple ports and multiple devices
 - Thermal foldback
 - Power foldback
- Liquid detection and corrosion mitigation

2 Applications

- [Automotive USB charging](#)
- [Automotive media hub](#)
- [Automotive head unit](#)

3 Description

The TPS26742E-Q1 is a stand-alone dual-port USB Type-C and power delivery (PD) source controller for any automotive USB-C port application including extended power range (EPR) voltages. The TPS26742E-Q1 is capable of supporting all USB-PD power supply negotiation options for standard power range (SPR) and EPR. The TPS26742E-Q1 automatically identifies USB-C cable capabilities, and adjusts for the maximum current allowed by the cable, without requiring an external 5V supply for VCONN. The TPS26742E-Q1 also supports legacy D+/D- charging.

The TPS26742E-Q1 controls a DC/DC via I²C or PWM to achieve a complete USB-C PD application. The TPS26742E-Q1 has SYNC outputs to keep external DC/DC switching out-of-phase for each port, with dual-random spread-spectrum (DRSS).

The TPS26742E-Q1 has integrated protections for thermal and input voltage monitoring for power foldback, VBUS high/low monitoring, and liquid detection along with corrosion mitigation.

The TPS26742E-Q1 offers multiple interface options for the system including I²C and LIN support, along with configurable GPIOs.

Package Information

PART NUMBER	PACKAGE ⁽¹⁾	PACKAGE SIZE (NOM)
TPS26742E-Q1	32-QFN (RHB)	5mm x 5mm

(1) For all available packages, see the orderable addendum at the end of the datasheet.

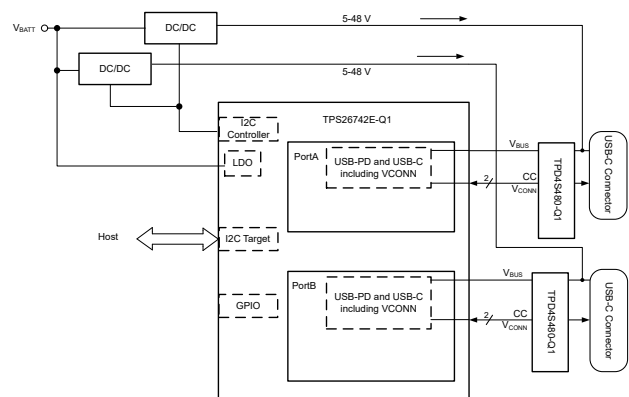

Table of Contents

1 Features	1	6.22 PWM Timer.....	19
2 Applications	1	6.23 Flash Memory Characteristics.....	19
3 Description	1	6.24 Boot Timing.....	19
4 Device Comparison Table	3	6.25 Typical Characteristics.....	20
5 Pin Configuration and Functions	4	7 Parameter Measurement Information	22
6 Specifications	7	8 Detailed Description	23
6.1 Absolute Maximum Ratings.....	7	8.1 Overview.....	23
6.2 ESD Ratings.....	7	8.2 Functional Block Diagram.....	24
6.3 Recommended Operating Conditions.....	7	8.3 Feature Description.....	25
6.4 Thermal Information.....	8	8.4 Device Functional Modes.....	49
6.5 Recommended Capacitance.....	8	9 Application and Implementation	52
6.6 Power Supply Characteristics.....	9	9.1 Application Information.....	52
6.7 Power Consumption Characteristics.....	9	9.2 Typical Application.....	52
6.8 Power Path Supervisory Characteristics.....	10	9.3 System Examples.....	57
6.9 CC Cable Detection Characteristics.....	10	9.4 Power Supply Recommendations.....	59
6.10 Legacy Charging Characteristics.....	11	9.5 Layout.....	59
6.11 Px_VCONN Switch Characteristics.....	11	10 Device and Documentation Support	61
6.12 CC PHY Characteristics.....	12	10.1 Documentation Support.....	61
6.13 Thermal Shutdown Characteristics.....	13	10.2 Receiving Notification of Documentation Updates..	61
6.14 Oscillator Characteristics.....	13	10.3 Support Resources.....	61
6.15 ADC Characteristics.....	13	10.4 Trademarks.....	61
6.16 Liquid Detection Characteristics.....	14	10.5 Electrostatic Discharge Caution.....	61
6.17 Input/Output (I/O) Characteristics (P0_GPIOx)	16	10.6 Glossary.....	61
6.18 Input/Output (I/O) Characteristics (P1_GPOx)	16	11 Revision History	62
6.19 I2C Requirements and Characteristics.....	16	12 Mechanical, Packaging, and Orderable Information	62
6.20 UART.....	18		
6.21 SYNC output.....	18		

4 Device Comparison Table

Device	Number of Ports	EPR Support	DisplayPort Support	Sink Mode Support
TPS26744E-Q1	2	Yes	Yes	No
TPS26742E-Q1	2	Yes	No	No
TPS26742Q1	2	No	No	No
TPS26743E-Q1	1	Yes	Yes	Yes
TPS26741Q1	1	No	No	No
TPS26741E-Q1	1	Yes	No	No

5 Pin Configuration and Functions

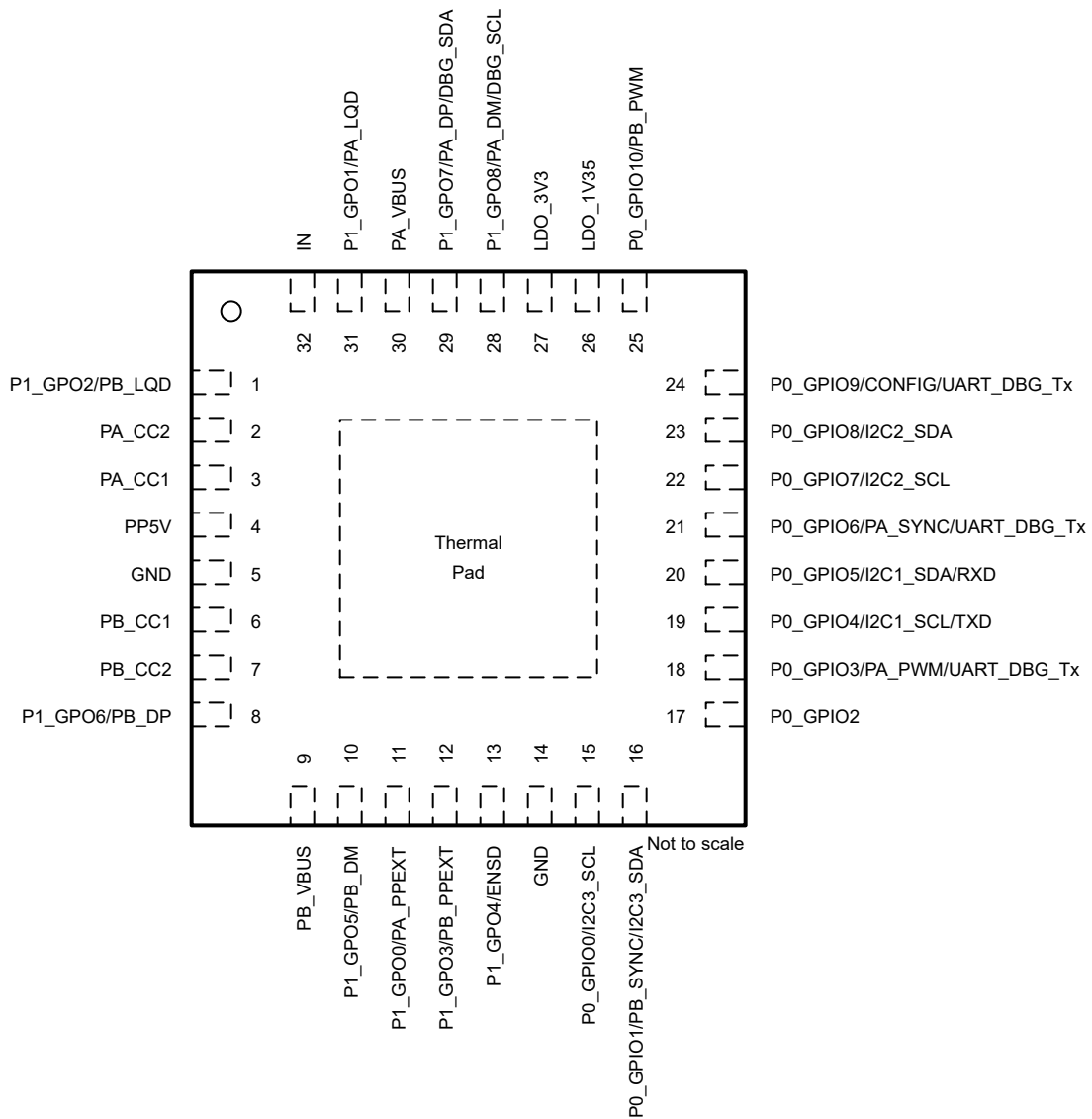

Figure 5-1. TPS26742E-Q1 RHB Package, 32-Pin QFN (Top View)

Table 5-1. Pin Functions

PIN		I/O ⁽¹⁾	DESCRIPTION
NAME	NO.		
GND	5, 14	GND	Ground reference pin. Connect to underside thermal pad.
IN	32	P	This is the input power supply for the device.
LDO_1V35	26	P	Output of internal LDO. Bypass with capacitance C_{LDO_1V35} to GND. This is not intended to source external circuits.
LDO_3V3	27	P	Output of internal LDO. Bypass with capacitance C_{LDO_3V3} to GND.
P0_GPIO0/I2C3_SCL	15	I/O	This pin supports multiple functions: General Purpose I/O, or SCL for I2C3.
P0_GPIO1/PB_SYNC/I2C3_SDA	16	I/O	This pin supports multiple functions: General Purpose I/O, SYNC output for PortB, or SDA for I2C3.
P0_GPIO10/PB_PWM	25	I/O	This pin supports multiple functions: General purpose I/O, or PWM output.
P0_GPIO2	17	I/O	General Purpose I/O.
P0_GPIO3/PA_PWM/UART_DBG_Tx	18	I/O	This pin supports multiple functions: General purpose I/O, PWM output, or UART debug output.
P0_GPIO4/I2C1_SCL/TXD	19	I/O	This pin supports multiple functions: General purpose I/O, SCL for the I2C1, or a LIN bus transmitter.
P0_GPIO5/I2C1_SDA/RXD	20	I/O	This pin supports multiple functions: General purpose I/O, SDA for I2C1, or a LIN bus receiver.
P0_GPIO6/PA_SYNC/UART_DBG_Tx	21	I/O	This pin supports multiple functions: General purpose I/O, SYNC output for PortA, or a debug output.
P0_GPIO7/I2C2_SCL	22	I/O	This pin supports multiple functions: General purpose I/O, or SCL for I2C2.
P0_GPIO8/I2C2_SDA	23	I/O	This pin supports multiple functions: General purpose I/O, SDA for I2C2.
P0_GPIO9/CONFIG/UART_DBG_Tx	24	I/O	This pin supports multiple functions: General purpose I/O, configuration input, or debug output.
P1_GPO0/PA_PPEXT/ADCIN2	11	I/O	This pin supports multiple functions: General Purpose Output, ADC input, or external power path control for port A.
P1_GPO1/PA_LQD/ADCIN3	31	I/O	This pin supports multiple functions: General Purpose Output, an ADC input, or liquid detection on Port A.
P1_GPO2/PB_LQD/ADCIN4	1	I/O	This pin supports multiple functions: General Purpose Output, ADC input or liquid detection on Port B.
P1_GPO3/PB_PPEXT/ADCIN5	12	I/O	This pin supports multiple functions: General Purpose Output, ADC input, or external power path control for port B.
P1_GPO4/ENSD	13	I/O	This pin supports multiple functions: General Purpose Output, or enable shutdown mode input (ENSD). Do not pull this pin down externally unless enabling shutdown mode.
P1_GPO5/PB_DM/ADCIN15	10	I/O	This pin supports multiple functions: General Purpose Output, ADC input, or connect to the D- pin on Port B for BC1.2.
P1_GPO6/PB_DP/ADCIN14	8	I/O	This pin supports multiple functions: General Purpose Output, ADC input, or connect to the D+ pin on Port B for BC1.2.
P1_GPO7/PA_DP/DBG_SDA/ADCIN12	29	I/O	This pin supports multiple functions: General Purpose Output, ADC input, connect to the D+ pin on Port A for BC1.2, or the SDA connection to I2C4.
P1_GPO8/PA_DM/DBG_SCL/ADCIN13	28	I/O	This pin supports multiple functions: General Purpose Output, ADC input, connect to the D- pin on Port A for BC1.2, or the SCL connection to I2C4.
PA_CC1	3	I/O	I/O for USB Type-C and USB PD. Filter noise with recommended capacitor to GND (C_{Px_CCy}).
PA_CC2	2	I/O	I/O for USB Type-C and USB PD. Filter noise with recommended capacitor to GND (C_{Px_CCy}).

Table 5-1. Pin Functions (continued)

PIN		I/O ⁽¹⁾	DESCRIPTION
NAME	NO.		
PA_VBUS	30	P	VBUS sense input for Port A. Bypass with capacitance C_{Px_VBUS} to GND.
PB_CC1	6	I/O	I/O for USB Type-C and USB PD. Filter noise with recommended capacitor to GND (C_{Px_CCy}).
PB_CC2	7	I/O	I/O for USB Type-C and USB PD. Filter noise with recommended capacitor to GND (C_{Px_CCy}).
PB_VBUS	9	P	VBUS sense input for Port B. Bypass with capacitance C_{Px_VBUS} to GND.
PP5V	4	P	Input supply for VCONN and output of LDO from the IN pin. Bypass with capacitance C_{PP5V} to GND.

6 Specifications

6.1 Absolute Maximum Ratings

over operating free-air temperature range (unless otherwise noted)⁽¹⁾

		MIN	MAX	UNIT
Input voltage range ⁽²⁾	PP5V	-0.3	7.0	V
	IN	-0.3	40	
	Px_VBUS	-0.3	40	V
	Px_DP, Px_DM, Px_LQD	-0.3	24	
	Px_CC1, Px_CC2	-0.5	24	
	P0_GPIOx	-0.3	V _{LDO_3V3} + 0.3 (4.1 MAX)	
	P1_GPO3, P1_GPO4	-0.3	6	
	P1_GPO0	-0.3	V _{LDO_3V3} + 0.3 (4.1 MAX)	
	I2Cx_SDA, I2Cx_SCL	-0.3	4	
Output voltage range ⁽²⁾	LDO_1V35 ⁽³⁾ ⁽⁴⁾	-0.3	2	V
	LDO_3V3 ⁽³⁾	-0.3	4	
Source current	Positive source current on Px_CCy	Internally limited		A
	Current sunk or sourced by Px_GPIOy	0.005		
	Positive sink current for I2Cn_SDA, I2Cn_SCL	Internally limited		
	Positive source current for LDO_3V3, PP5V	Internally limited		
T _J Operating junction temperature		-40	155	°C
T _{STG} Storage temperature		-55	150	°C

- (1) Operation outside the *Absolute Maximum Ratings* may cause permanent device damage. *Absolute Maximum Ratings* do not imply functional operation of the device at these or any other conditions beyond those listed under *Recommended Operating Conditions*. If used outside the *Recommended Operating Conditions* but within the *Absolute Maximum Ratings*, the device may not be fully functional, and this may affect device reliability, functionality, performance, and shorten the device lifetime.
- (2) All voltage values are with respect to network GND. Connect the GND pin directly to the GND plane of the board.
- (3) Do not apply voltage to these pins.
- (4) Do not apply any external load to this pin.

6.2 ESD Ratings

PARAMETER		TEST CONDITIONS	VALUE	UNIT	
V _(ESD)	Electrostatic discharge	Human body model (HBM), per ANSI/ESDA/JEDEC JS-001 ⁽¹⁾	All pins	±2000	V
			Px_CCy pins	±6000	
		Charged device model (CDM), per ANSI/ESDA/JEDEC JS-002	Corner pins	±750	
			All pins	±500	

- (1) AEC Q100-002 indicates that HBM stressing shall be in accordance with the ANSI/ESDA/JEDEC JS-001 specification.

6.3 Recommended Operating Conditions

		MIN	NOM	MAX	UNIT	
V _I	Input voltage range ⁽¹⁾	IN (when used as Px_VCONN supply)	5	12	32	V
		IN ⁽²⁾	4.5	12	32	
		PP5V (if supplied externally)	4.75	5	min(5.5, V _{IN})	
		Px_VBUS	0		31	

6.3 Recommended Operating Conditions (continued)

			MIN	NOM	MAX	UNIT
V _{IO}	I/O voltage range ⁽¹⁾	I2Cx_SDA, I2Cx_SCL	0		V _{LDO_3V3}	V
		P0_GPIOx	0		V _{LDO_3V3}	
		P1_GPO0, P1_GPO3, P1_GPO4	0		V _{LDO_3V3}	
		Px_CC1, Px_CC2	0		5.5	
		Px_DP, Px_DM, Px_LQD	0		5.5	
I _O	Output current (from PP5V)	Px_CC1, Px_CC2 (when V _{IN} > 7V)			25	mA
I _O	Output current (from LDO_3V3)	P0_GPIOx, P1_GPOx			1	mA
I _O	Output current (from internal LDO)	Sum of current from LDO_3V3 and P0_GPIOx and P1_GPOx.			10	mA
T _A	Ambient operating temperature		-40		125	°C

(1) All voltage values are with respect to network GND. Connect all GND pins directly to the GND plane of the board.

(2) When the device first powers up, V_{ENSD} > V_{ENSD_THLD} (rising) is required.

6.4 Thermal Information

THERMAL METRIC ⁽¹⁾		DEVICE	UNIT
		QFN (RHB)	
		32 PINS	
R _{θJA}	Junction-to-ambient thermal resistance	32.5	°C/W
R _{θJC} (top)	Junction-to-case (top) thermal resistance	21.6	°C/W
R _{θJB}	Junction-to-board thermal resistance	12.6	°C/W
Ψ _{JT}	Junction-to-top characterization parameter	1.3	°C/W
Ψ _{JB}	Junction-to-board characterization parameter	12.5	°C/W
R _{θJC} (bottom)	Junction-to-case (bottom GND pad) thermal resistance	3.2	°C/W

(1) For more information about traditional and new thermal metrics, see the [Semiconductor and IC Package Thermal Metrics](#) application report.

6.5 Recommended Capacitance

over operating free-air temperature range (unless otherwise noted)

PARAMETER ⁽¹⁾		VOLTAGE RATING	MIN	NOM	MAX	UNIT
C _{Px_VBUS}	Capacitance on Px_VBUS ⁽³⁾	50 V		1		μF
C _{IN}	Capacitance on IN	50 V	0.5	1		μF
C _{LDO_3V3}	Capacitance on LDO_3V3	6.3 V	2	4.7		μF
C _{LDO_1V35}	Capacitance on LDO_1V35	4 V		470		nF
C _{PP5V}	Capacitance on PP5V (Px_VCONN not used)	10 V	2			μF
	Capacitance on PP5V (for eMarker setting)	10 V	5			μF
C _{PP5V2} ⁽²⁾	Second capacitance on PP5V pin	10 V		100		nF
C _{Px_CCy}	Capacitance on Px_CCy pins when USB-PD PHY is active ⁽⁴⁾ .	50 V		300		pF

6.5 Recommended Capacitance (continued)

over operating free-air temperature range (unless otherwise noted)

PARAMETER ⁽¹⁾		VOLTAGE RATING	MIN	NOM	MAX	UNIT
C _{DPDM}	Capacitance on Px_DP and Px_DM when used in DCP mode	50V			1	nF

- (1) Capacitance values do not include any derating or tolerance factors. For example, if 4.5 μ F is required and the external capacitor value diminishes by 50% due to derating at the required operating voltage and has -10% tolerance, then an external capacitor with nominal value of 10 μ F is recommended.
- (2) Place this capacitor for best ESD performance.
- (3) Place this capacitance is near the Px_VBUS pin.
- (4) The voltage rating given assumes the capacitance is placed near the Px_CCy pin. However, this capacitance need not be placed near the Px_CCy pin.

6.6 Power Supply Characteristics

over operating free-air temperature range (unless otherwise noted)

PARAMETER		TEST CONDITIONS	MIN	TYP	MAX	UNIT
I _{IN_LKG}	Leakage on the IN pin when 5V LDO disabled (PP5V supplied externally above V _{PP5V}).	V _{PP5V} = 5V, V _{IN} =7V, T _J =125°C		7.2		μ A
		V _{PP5V} = 5V, V _{IN} =12V, T _J =125°C		14.1		μ A
		V _{PP5V} = 5V, V _{IN} =18V		22	40	μ A
Outputs						
V _{PP5V}	Voltage on PP5V when sourced by the internal LDO	7V \leq V _{IN} \leq 18 V, V _{EN} = 2 V, P _{X_VCONN} enabled.	4.5	4.63	4.75	V
V _{PP5V}	Voltage on PP5V when sourced by the internal LDO	4.5V \leq V _{IN} < 7V, V _{EN} = 2 V, P _{X_VCONN} disabled.	4.2	4.63	4.75	V
V _{LDO_3V3}	Voltage on LDO_3V3	V _{PP5V} > V _{PP5V_UVLO}	3.0	3.3	3.45	V
V _{LDO_1V35}	Output voltage of LDO_1V35	V _{LDO_3V3} \geq 3.0V, up to maximum internal loading condition.		1.35		V

6.7 Power Consumption Characteristics

over operating free-air temperature range (unless otherwise noted)

PARAMETER		TEST CONDITIONS	MIN	TYP	MAX	UNIT
Active Mode						
I _{IN,Act} ⁽¹⁾	current into IN	Active mode: V _{PP5V} =5.0V, V _{IN} =7V, all P0_GPIOx and P1_GPOx disabled, no external loading on PP5V or LDO_3V3		7.6	15	mA
Sleep Mode						
I _{IN,Sleep} ⁽¹⁾	current into IN	V _{IN} =12V, all P0_GPIOx and P1_GPOx disabled, no external loading on PP5V or LDO_3V3, T _J = 25 °C		1.8		mA
Idle Mode						
I _{IN,Idle} ⁽¹⁾	current into IN	V _{IN} =12V, all P0_GPIOx and P1_GPOx disabled, no external loading on PP5V or LDO_3V3, T _J = 25 °C		3.4		mA
Shutdown Mode						
I _{IN,SD} ⁽¹⁾	Shutdown current into IN	V _{IN} =12V, V _{ENSD} =0V, no external loading on PP5V, LDO_3V3		1		mA

- (1) Typical numbers are averaged over 1 second. Firmware configurations affect this power consumption.

6.8 Power Path Supervisory Characteristics

over operating free-air temperature range (unless otherwise noted)

PARAMETER		TEST CONDITIONS	MIN	TYP	MAX	UNIT
Overvoltage						
V _{PP5V_OVP}	VBUS overvoltage (rising)	OVP detected when V _{Px_CCy} > V _{PP5V_OVP} , and VCONN being sourced through Px_CCy	5.85	6.15	6.55	V
	VBUS overvoltage (falling)		5.4	5.7	6.0	
	VBUS overvoltage (hysteresis)		0.45			
Undervoltage						
V _{PP5V_UVLO}	Voltage required on PP5V	Rising	3.9	4.1	4.3	V
		Falling	3.8	4.0	4.2	
		Hysteresis	0.1			
V _{VBUS_GOOD}	Comparator for Px_VBUS	Rising	3.75			V
		Falling	3.65			
		Hysteresis	0.10			
VBUS Discharge						
I _{DSCH}	VBUS discharge current (1)	30V ≥ V _{Px_VBUS} ≥ V _{LDO_3V3} , measure I _{Px_VBUS}	8			mA

(1) The discharge is enabled automatically when needed to meet USB specifications and disabled automatically when not needed.

6.9 CC Cable Detection Characteristics

over operating free-air temperature range (unless otherwise noted)

PARAMETER		TEST CONDITIONS	MIN	TYP	MAX	UNIT
Type-C Source (Rp pull-up)						
V _{SRC1}	Detach threshold for Rp3.0A applied to Px_CCy	Rising	2.56	2.74		V
		Falling	2.46	2.64		
		Hysteresis	0.1			
V _{SRC2}	Detach threshold for Rp1.5A or RpDef applied to Px_CCy	Rising	1.54	1.64		V
		Falling	1.51	1.61		
		Hysteresis	0.03			
V _{SRC3}	Ra/Rd detection threshold for RpDef applied to Px_CCy	Rising	0.20	0.24		V
		Falling	0.16	0.18	0.20	
		Hysteresis	0.04			
V _{SRC4}	Ra/Rd detection threshold for Rp1.5A applied to Px_CCy	Rising	0.39	0.44		V
		Falling	0.35	0.40		
		Hysteresis	0.04			
V _{SRC5}	Ra/Rd detection threshold for Rp3.0A applied to Px_CCy	Rising	0.79	0.84		V
		Falling	0.75	0.80		
		Hysteresis	0.04			
V _{OC}	Px_CCy open circuit voltage while Rp enabled, no load	V _{PP5V_UVLO} < V _{PP5V} < 5.5 V, R _{CC} = 47 kΩ	2.95			V
I _{RpDef}	Current source - USB Default	V _{PP5V} ≥ 4.5V, 0 < V _{Px_CCy} < 1.5 V, measure I _{Px_CCy}	73	80	87	μA
I _{Rp1.5}	Current source - 1.5A	V _{PP5V} ≥ 4.5V, 0 < V _{Px_CCy} < 1.5 V, measure I _{Px_CCy}	166	180	194	μA
I _{Rp3.0}	Current source - 3.0A	V _{PP5V} ≥ 4.5V, 0 < V _{Px_CCy} < 2.45 V, measure I _{Px_CCy}	304	330	356	μA
Z _{Open}	Unpowered CC impedance	V _{IN} =0V, V _{Px_CCy} = 3.3V	126			kΩ

6.9 CC Cable Detection Characteristics (continued)

over operating free-air temperature range (unless otherwise noted)

PARAMETER		TEST CONDITIONS	MIN	TYP	MAX	UNIT
R _{Open}	Resistance from P _X _CCy to GND when configured as open.	V _{PX_VBUS} = 0, V _{IN} =V _{PP5V} =5.0V, V _{PX_CCy} =5 V, measure resistance on P _X _CCy	126			kΩ
Timing						
R _a	R _a pulldown resistance	V _{PX_CCy} ≤ 0.25 V, measure resistance on P _X _CCy, the minimum value is flexible in order to avoid needing any trim.			1200	Ω
t _{CC}	Default deglitch time for comparators on P _X _CCy			3.6		ms

6.10 Legacy Charging Characteristics

Over operating free-air temperature range (unless otherwise noted)

PARAMETER		TEST CONDITIONS	MIN	TYP	MAX	UNIT
BC1.2						
R _{DCP}	P _X _DP and P _X _DM shorting resistance			70		Ω
V _{DM_SRC}	P _X _DM output voltage	0 < I _{PX_DM} < 250 μA		0.6		V
I _{DP_SNK}	P _X _DP sink current	0.25V ≤ V _{PX_DP} ≤ 2.0 V		100		μA
V _{DAT_REF}	DP_IN rising lower window threshold for V _{DM_SRC} activation			0.38		V
	Hysteresis			50		mV
V _{LGC_SRC}	DP_IN rising upper window threshold for V _{DM_SRC} deactivation			0.95		V
	Hysteresis			100		mV

6.11 P_X_VCONN Switch Characteristics

over operating free-air temperature range (unless otherwise noted)

PARAMETER		TEST CONDITIONS	MIN	TYP	MAX	UNIT
R _{VCONN}	R _{dson} of the VCONN path	V _{PP5V} =5V, I _{PX_CCy} = 350 mA, measure resistance from PP5V to P _X _CCy		0.7		Ω
I _{LIMVC}	Short circuit current limit	eMarker-only setting, V _{PP5V} =5V, R _L =10mΩ, measure I _{PX_CCy}		50		mA
V _{VCONN_RCP}	Reverse current protection threshold for P _X _VCONN, sourcing VCONN through P _X _CCy	V _{PP5V} ≥ 4.9 V, V _{PX_CCz} = V _{PP5V} , V _{PX_CCy} rising		200		mV
	Reverse current protection threshold for P _X _VCONN, sourcing VCONN through CCx	V _{PP5V} ≥ 4.9 V, V _{PX_CCz} ≤ 4.0V, V _{PX_CCy} rising		340		mV
t _{VCILIM}	Current clamp deglitch time.			3		ms
t _{VC_OVP}	Response time to V _{PX_CCy} > V _{PP5V_OVP} , while VCONN is sourced through P _X _CCy	Enable P _X _VCONN, apply 100 Ω load on PP5V, ramp V _{PX_CCy} up starting from 4.3V at 100 V/ms		150		μs

6.11 Px_VCONN Switch Characteristics (continued)

over operating free-air temperature range (unless otherwise noted)

PARAMETER		TEST CONDITIONS	MIN	TYP	MAX	UNIT
t_{VC_UVLO}	Response time to $V_{PP5V} < V_{PP5V_UVLO}$	$R_L = 100 \Omega$, no external capacitance on Px_CCy, ramp V_{PP5V} from 5.5V to 3.5V at 10V/ μ s, measure time from UVLO detection until current < 10mA		4		μ s
t_{VC_RCP}	Response time to $V_{PP5V} < V_{Px_CCy} + V_{VCONN_RCP}$	$V_{PP5V} = 5.5V$, enable Px_VCONN, ramp V_{Px_CCy} from 4V to 21.5V at 10 V/ μ s		1		μ s
t_{VCON}	From enable signal to Px_CCy at 90% of final value	$I_L = 250 \text{ mA}$, $V_{PP5V} = 5V$, $C_L = 0$		0.98		ms
t_{VCOFF}	From disable signal to Px_CCy at 10% of final value	$I_L = 250 \text{ mA}$, $V_{PP5V} = 5V$, $C_L = 0$		0.22		ms
t_{VCRISE}	Px_CCy from 10% to 90% of final value	$I_L = 250 \text{ mA}$, $V_{PP5V} = 5V$, $C_L = 0$		270		μ s
t_{VCFALL}	Px_CCy from 90% to 10% of initial value	$I_L = 250 \text{ mA}$, $V_{PP5V} = 5V$, $C_L = 0$		250		μ s
t_{IOS_VCONN}	Response time to short circuit	$V_{PP5V} = 5V$, for short circuit $R_L = 10m\Omega$. Measure time from short being applied until $I_{VCONN} < I_{LIMVC}$.			4.0	μ s
		$V_{PP5V} = 5V$, for short circuit $R_L = 10m\Omega$. Measure time from short being applied until $I_{VCONN} < I_{LIMVC}$. eMarker-only setting.			0.6	

6.12 CC PHY Characteristics

over operating free-air temperature range (unless otherwise noted)

PARAMETER		TEST CONDITIONS	MIN	TYP	MAX	UNIT
Transmitter						
V_{TXHI}	Transmit high voltage on Px_CCy	Standard External load	1.05	1.125	1.2	V
V_{TXLO}	Transmit low voltage on Px_CCy	Standard External load	-75		75	mV
Z_{DRIVER}	Transmit output impedance while driving the CC line using Px_CCy		33	50	71.4	Ω
t_{TX_RISE}	Rise time. 10 % to 90 % amplitude points on Px_CCy, minimum is under an unloaded condition. Maximum set by TX mask	$C_{Px_CCy} = 520 \text{ pF}$	300			ns
t_{TX_FALL}	Fall time. 90 % to 10 % amplitude points on Px_CCy, minimum is under an unloaded condition. Maximum set by TX mask	$C_{Px_CCy} = 520 \text{ pF}$	300			ns
t_{UI}	Unit interval for data bit during transmission on Px_CCy		3.03		3.7	μ s
Receiver						
C_{CC}	Receiver capacitance on Px_CCy ⁽²⁾	Capacitance looking into the CC pin when in receiver mode			100	pF
$t_{RxFilter}^{(1)}$	Rx bandwidth limiting filter. Time constant of a single pole filter to limit broadband noise ingress		100			ns

6.12 CC PHY Characteristics (continued)

over operating free-air temperature range (unless otherwise noted)

PARAMETER		TEST CONDITIONS	MIN	TYP	MAX	UNIT
V _{RX_SRC}	Threshold on Px_CCy for receiver comparator	Source mode (rising)	775	825	875	mV
		Source mode (falling)	500	550	600	

- (1) Broadband noise ingress is due to coupling in the cable interconnect.
- (2) C_{CC} includes only the internal capacitance on a Px_CCy pin when the pin is configured to be receiving BMC data. External capacitance is needed to meet the required minimum capacitance per the USB-PD Specifications (cReceiver). Therefore, TI recommends adding C_{Px_CCy} externally.

6.13 Thermal Shutdown Characteristics

over operating free-air temperature range (unless otherwise noted)

PARAMETER		TEST CONDITIONS	MIN	TYP	MAX	UNIT
T _{SD}	Temperature shutdown threshold	Temperature rising	140	158.5	175	°C
		Temperature falling	125	143.5	162	°C
		Hysteresis		15		°C
T _{SD_PP}	Temperature controlled shutdown threshold for each power path of the port.	Temperature rising	125	145	165	°C
		Temperature falling	110	130	150	°C
		Hysteresis		15		°C

6.14 Oscillator Characteristics

over operating free-air temperature range (unless otherwise noted)

PARAMETER		TEST CONDITIONS	MIN	TYP	MAX	UNIT
f _{OSC_24M}	24MHz oscillator		22.5	24	25.2	MHz

6.15 ADC Characteristics

over operating free-air temperature range (unless otherwise noted)

PARAMETER		TEST CONDITIONS	MIN	TYP	MAX	UNIT
LSB	Least significant bit	3.6V max scaling, voltage divider of 3		3.52		mV
		6.0V max scaling, voltage divider of 5		5.86		mV
		51.2V max scaling, voltage divider of 42.7		50		mV
		See (1)		0.45		°C
GAIN_ERR	Gain error (including the input divider)	0.05V ≤ V _{GPIOx} ≤ V _{LDO_3V3}	-2.7		2.7	%
		2.7V ≤ V _{LDO_3V3} ≤ 3.6V	-2.4		2.4	
		85°C ≤ T _J ≤ 125°C	-12		12	
		0.15V ≤ V _{Px_CCy} ≤ 5.5V	-3		3	
		7V ≤ V _{IN} ≤ 31V	-2.1		2.1	
		0.6V ≤ V _{Px_VBUS} ≤ 31V	-2.1		2.1	

6.15 ADC Characteristics (continued)

over operating free-air temperature range (unless otherwise noted)

PARAMETER		TEST CONDITIONS	MIN	TYP	MAX	UNIT
VOS_ERR	Offset error (referred to the input pin)	$0.05V \leq V_{GPIOx} \leq V_{LDO_3V3}$	-12.3		12.3	mV
		$2.7V \leq V_{LDO_3V3} \leq 3.6V$	-12.3		12.3	mV
		$85^{\circ}C \leq T_J \leq 125^{\circ}C$	-2		2	°C
		$0.15V \leq V_{Px_CCy} \leq 5.5V$	-20.5		20.5	mV
		$7V \leq V_{IN} \leq 31V$	-175		175	mV
		$0.6V \leq V_{Px_VBUS} \leq 31V$	-175		175	mV

(1) Temperature in degC = (ADC data - 650)*0.45 + 25

6.16 Liquid Detection Characteristics

over operating free-air temperature range (unless otherwise noted)

PARAMETER		TEST CONDITIONS	MIN	TYP	MAX	UNIT
I _{LQD}	Weak pullup on Px_LQD	$V_{PP5V} \geq 4.5V, 0 < V_{Px_LQD} < 2.0 V,$ measure I _{Px_LQD}		40		μA
	Strong pullup on Px_LQD	$V_{PP5V} \geq 4.5V, 0 < V_{Px_LQD} < 2.0 V,$ measure I _{Px_LQD}		80		
	Strong pullup on Px_LQD	$V_{PP5V} \geq 4.5V, 0 < V_{Px_LQD} < 2.0 V,$ measure I _{Px_LQD}		160		

6.16 Liquid Detection Characteristics (continued)

over operating free-air temperature range (unless otherwise noted)

PARAMETER		TEST CONDITIONS	MIN	TYP	MAX	UNIT
V _{LQD}	Threshold on Px_LQD comparator (Rising)	setting 0		0.200		V
		setting 1		0.225		
		setting 2		0.250		
		setting 3		0.275		
		setting 4		0.300		
		setting 5		0.325		
		setting 6		0.350		
		setting 7		0.500		
		setting 8		0.700		
		setting 9		0.800		
		setting 10		0.850		
		setting 11		0.900		
		setting 12		0.950		
		setting 13		1.000		
		setting 14		1.050		
		setting 15		1.100		
		setting 16		1.150		
		setting 17		1.200		
		setting 18		1.250		
		setting 19		1.300		
		setting 20		1.350		
		setting 21		1.400		
		setting 22		1.450		
		setting 23		1.500		
		setting 24		1.550		
		setting 25		1.600		
		setting 26		1.650		
		setting 27		1.700		
		setting 28		1.750		
		setting 29		1.800		
		setting 30		1.850		
		setting 31		1.900		
V _{LQD_OVP}	OVP threshold on Px_LQD	Rising	6		9.5	V
V _{Px_LQD}	Px_LQD voltage when R _{LQD} and I _{LQD} applied	R _{LQD} =5kΩ, I _{LQD} =80μA		0.4		V
		R _{LQD} =10kΩ, I _{LQD} =40μA		0.4		
		R _{LQD} =12.5kΩ, I _{LQD} =160μA		2.0		
		R _{LQD} =25kΩ, I _{LQD} =80μA		2.0		
R _{LQD}	Weak pulldown on Px_LQD	V _{Px_LQD} =0.4V, I _{LQD} =80μA		5		kΩ
		V _{Px_LQD} =0.4V, I _{LQD} =40μA		10		
		V _{Px_LQD} =2.0V, I _{LQD} =160μA		12.5		
		V _{Px_LQD} =2.0V, I _{LQD} =80μA		25		

6.17 Input/Output (I/O) Characteristics (P0_GPIOx)

over operating free-air temperature range (unless otherwise noted)

PARAMETER		TEST CONDITIONS	MIN	TYP	MAX	UNIT
Input						
GPIO_VIH	P0_GPIOx high-Level input voltage, configured for $V_{IO}=3.3V$	$V_{LDO_3V3} = 3.3V, 0.7*V_{IO}$	2.31			V
GPIO_VIL	P0_GPIOx low-Level input voltage, configured for $V_{IO}=3.3V$	$V_{LDO_3V3} = 3.3V, 0.3*V_{IO}$			0.99	V
GPIO_HYS	P0_GPIOx input hysteresis voltage, configured for $V_{IO}=3.3V$	$V_{LDO_3V3} = 3.3V, 0.05*V_{IO}$		0.15		V
GPIO_ILKG	P0_GPIOx leakage current	$V_{GPIOx}=V_{LDO_3V3}=3.3V, T_J \leq 85^\circ C$	-1		1	μA
Output						
GPIO_RPU	P0_GPIOx internal pull-up	Pull-up enabled		40		k Ω
GPIO_RPD	P0_GPIOx internal pull-down	Pull-down enabled		40		k Ω
GPIO_VOH	Output high voltage for P0_GPIOx	$V_{LDO_3V3} = 3.3V, I_{GPIOx}=2mA$	2.64			V
GPIO_VOL	Output low voltage for P0_GPIOx	$V_{LDO_3V3} = 3.3V, I_{GPIOx}=2mA$			0.4	V

6.18 Input/Output (I/O) Characteristics (P1_GPOx)

over operating free-air temperature range (unless otherwise noted)

PARAMETER		TEST CONDITIONS	MIN	TYP	MAX	UNIT
GPIO_ILKG	GPIOx leakage current, GPIO_RPU and GPIO_RPD disabled	$V_{GPIOx} = V_{LDO_3V3}$	-1		1	μA
		$V_{GPIOx} = 5.5V, V_{LDO_3V3} = 3.3V$ (only applies to x=1, 2, and 5-8)	-1		1	
Output						
GPIO_RPU	GPIOx internal pull-up	Pull-up enabled		100		k Ω
GPIO_RPD	GPIOx internal pull-down	Pull-down enabled		100		k Ω
GPIO_VOH	GPIOx output high voltage	$V_{LDO_3V3} = 3.3V, I_{P1_GPOx} = -2mA$	2.9			V
GPIO_VOL	GPIOx output low voltage	$V_{LDO_3V3} = 3.3V, I_{P1_GPOx} = 2mA$			0.4	V
Alternate functions						
V_{ENSD_THLD}	Input threshold for the ENSD functionality	rising		0.66		V
		falling		0.56		
		hysteresis		0.1		
T_{ENSD_DEG}	Deglitch time for ENSD input	$V_{ENSD} < V_{ENSD_THLD}$ constantly for this time for ENSD to be deemed low			300	μs

6.19 I2C Requirements and Characteristics

over operating free-air temperature range (unless otherwise noted)

PARAMETER		TEST CONDITIONS	MIN	TYP	MAX	UNIT
SDA and SCL Common Characteristics (Controller, Target)						
I_{OL}	Max output low current	$V_{OL}=0.4V$	10	17.3		mA
I_{OL}	Max output low current	$V_{OL}=0.6V$	15	23.6		mA
t_f	Fall time from $0.7*V_{IO}$ to $0.3*V_{IO}$	$C_b = 10pF, R_p=14k\Omega$	0.3		120	ns
		$C_b = 400pF, R_p=330\Omega$	12		120	ns
t_{SP}	I2C pulse width suppressed				50	ns
C_i	Pin capacitance (internal)				10	pF

6.19 I2C Requirements and Characteristics (continued)

over operating free-air temperature range (unless otherwise noted)

PARAMETER		TEST CONDITIONS	MIN	TYP	MAX	UNIT
C_b	Capacitive load for each bus line (external)				400	pF
SDA and SCL Standard Mode Characteristics (Target)						
f_{SCL}	Clock frequency				100	kHz
$t_{VD;DAT}$	Valid data time	Transmitting Data, SCL low to SDA output valid			3.45	μ s
$t_{VD;ACK}$	Valid data time of ACK condition	Transmitting Data, ACK signal from SCL low to SDA (out) low			3.45	μ s
SDA and SCL Fast Mode Characteristics (Target)						
f_{SCL}	Clock frequency		100		400	kHz
$t_{VD;DAT}$	Valid data time	Transmitting data, SCL low to SDA output valid			0.9	μ s
$t_{VD;ACK}$	Valid data time of ACK condition	Transmitting data, ACK signal from SCL low to SDA (out) low			0.9	μ s
SDA and SCL Fast Mode Plus Characteristics (Target)						
f_{SCL}	Clock frequency		400		1000	kHz
$t_{VD;DAT}$	Valid data time	Transmitting data, SCL low to SDA output valid			0.45	μ s
$t_{VD;ACK}$	Valid data time of ACK condition	Transmitting data, ACK signal from SCL low to SDA (out) low			0.45	μ s
SDA and SCL Standard Mode Characteristics (Controller)						
f_{SCL}	Clock frequency for controller ⁽¹⁾			90		kHz
$t_{HD;STA}$	Start or repeated start condition hold time		4			μ s
$t_{HD;DAT}$	Serial data hold time (Controller mode)		0	7.7		ns
t_{LOW}	Clock low time		4.7			μ s
t_{HIGH}	Clock high time		4			μ s
$t_{SU;STA}$	Start or repeated start condition setup time		4.7			μ s
$t_{SU;DAT}$	Serial data setup time	Transmitting	250			ns
$t_{SU;STO}$	Stop condition setup time		4			μ s
t_{BUF}	Bus free time between stop and start		4.7			μ s
$t_{VD;DAT}$	Valid data time	Transmitting data, SCL low to SDA output valid			3.45	μ s
$t_{VD;ACK}$	Valid data time of ACK condition	Transmitting data, ACK signal from SCL low to SDA (out) low			3.45	μ s
SDA and SCL Fast Mode Characteristics (Controller)						
f_{SCL}	Clock frequency for controller ⁽¹⁾			325		kHz
$t_{HD;STA}$	Start or repeated start condition hold time		0.6			μ s
$t_{HD;DAT}$	Serial data hold time (Controller mode)		0	3.9		ns
t_{LOW}	Clock low time		1.3			μ s
t_{HIGH}	Clock high time		0.6			μ s
$t_{SU;STA}$	Start or repeated start condition setup time		0.6			μ s
$t_{SU;DAT}$	Serial data setup time	Transmitting	100			ns

6.19 I2C Requirements and Characteristics (continued)

over operating free-air temperature range (unless otherwise noted)

PARAMETER		TEST CONDITIONS	MIN	TYP	MAX	UNIT
t _{SU,STO}	Stop condition setup time		0.6			µs
t _{BUF}	Bus free time between stop and start		1.3			µs
t _{VD,DAT}	Valid data time	Transmitting data, SCL low to SDA output valid			0.9	µs
t _{VD,ACK}	Valid data time of ACK condition	Transmitting data, ACK signal from SCL low to SDA (out) low			0.9	µs
SDA and SCL Fast Mode Plus Characteristics (Controller)						
f _{SCL}	Clock frequency for controller ⁽¹⁾			708		kHz
t _{HD,STA}	Start or repeated start condition hold time		0.26			µs
t _{HD,DAT}	Serial data hold time (Controller mode)		0	3.2		ns
t _{LOW}	Clock low time		0.5			µs
t _{HIGH}	Clock high time		0.26			µs
t _{SU,STA}	Start or repeated start condition setup time		0.26			µs
t _{SU,DAT}	Serial data setup time	Transmitting	50			ns
t _{SU,STO}	Stop condition setup time		0.26			µs
t _{BUF}	Bus free time between stop and start		0.5			µs
t _{VD,DAT}	Valid data time	Transmitting data, SCL low to SDA output valid			0.45	µs
t _{VD,ACK}	Valid data time of ACK condition	Transmitting data, ACK signal from SCL low to SDA (out) low			0.45	µs

(1) Actual frequency is dependent upon bus capacitance.

6.20 UART

over operating free-air temperature range (unless otherwise noted)

PARAMETERS		TEST CONDITIONS	MIN	TYP	MAX	UNIT
f _{BITCLK}	BITCLK clock frequency (equals baud rate in MBaud)				12	MHz

6.21 SYNC output

over operating free-air temperature range (unless otherwise noted)

PARAMETER		TEST CONDITIONS	MIN	TYP	MAX	UNIT
f _{SYNC_NOM}	Nominal frequency of Px_SYNC output		0.1		2.2	MHz
N _{SYNC_NOM}	Configurable nominal SYNC frequency: f _{SYNC_NOM} = f _{OSC_24M} / N _{SYNC_NOM} .		1		255	
f _{SYNC_SWING}	Frequency swing of Px_SYNC output		-10		10	%
N _{MOD}	Configurable modulation frequency: f _{MOD} = 6000/N _{MOD} .		461		666	
f _{MOD}	Modulation frequency of Px_SYNC output.		9		13	kHz

6.22 PWM Timer

over operating free-air temperature range (unless otherwise noted)

PARAMETER		TEST CONDITIONS	MIN	TYP	MAX	UNIT
N _{PWM}	Maximum number of bits in the PWM counter			13		Bits
T _{PWM_ON}	ON time of the PWM cycle		0		0.341	ms
T _{PWM_TOTAL}	Period of the PWM cycle		0		0.341	ms
T _{PWM_PERIOD}	Configurable period for PWM duty-cycle to automatically transition from 100% to 0% and back to 100%.		0.082		2.6	s

6.23 Flash Memory Characteristics

over operating free-air temperature range (unless otherwise noted)

PARAMETER		TEST CONDITIONS	MIN	TYP	MAX	UNIT
Size						
	Flash size (per bank)			144		kB
	Number of banks			1		
Supply						
I _{DDERASE}	Supply current from VDD during erase operation	Supply current delta			10	mA
I _{DDPGM}	Supply current from VDD during program operation	Supply current delta			10	mA
Endurance						
NW _{EC(UPPER)}	Erase/program cycle endurance (remaining flash)	-40°C ≤ T _J ≤ 105°C	10			k cycles
NW _(MAX)	Write operations per word line before sector erase ⁽¹⁾				83	write operations
Retention						
t _{RET_105}	Flash memory data retention	-40°C ≤ T _J ≤ 105°C	11.4			years

- (1) This parameter specifies the maximum number of write operations allowed per word line before erasing the word line is required. If additional writes to the same word line are required, a sector erase is required once the maximum number of write operations per word line is reached.

6.24 Boot Timing

over operating free-air temperature range (unless otherwise noted)

PARAMETER		TEST CONDITIONS	MIN	TYP	MAX	UNIT
t _{BOOT}	Time from LDO_3V3 going high until firmware enters 'APP' mode			1.5		s
t _{TFU}	Time required to update the FW image via I2C	f _{SCL} = 1MHz, using I2C1 or I2C4		13		s
		f _{SCL} = 400kHz, using I2C1 or I2C4		14		
		f _{SCL} = 100kHz, using I2C1 or I2C4		27		

6.25 Typical Characteristics

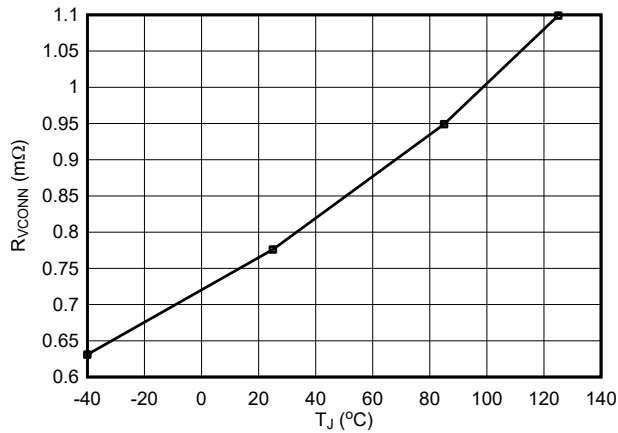

Figure 6-1. VCONN Switch Resistance

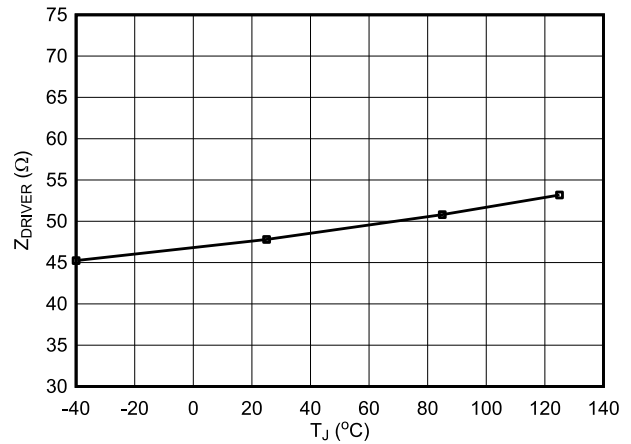

Figure 6-2. USB-PD PHY Transmit Impedance

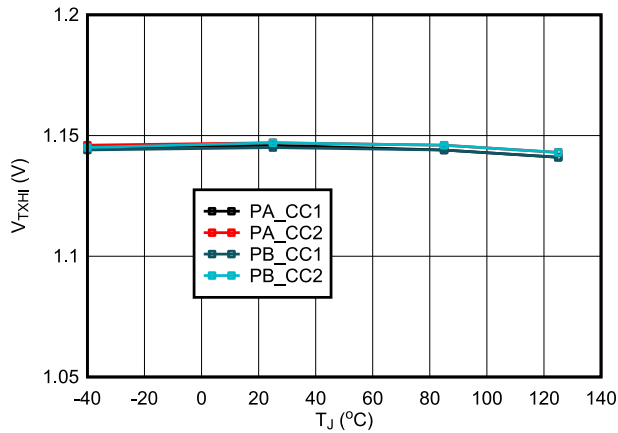

Figure 6-3. USB-PD PHY Transmit High Voltage

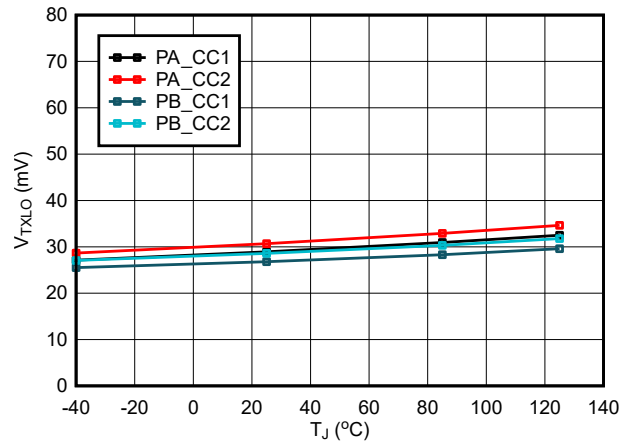

Figure 6-4. USB-PD PHY Transmit Low Voltage

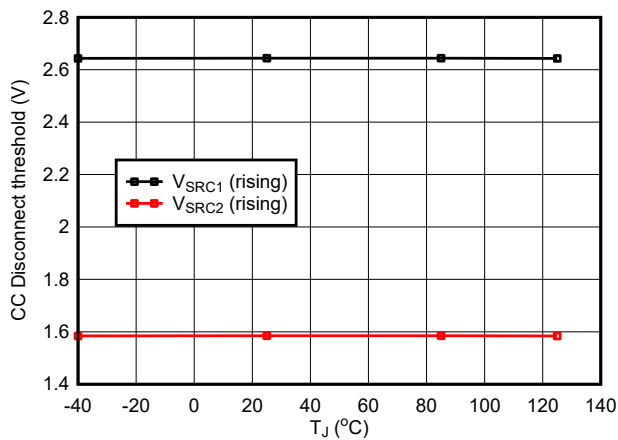

Figure 6-5. Disconnect Voltage Thresholds on Px_CCy Pins

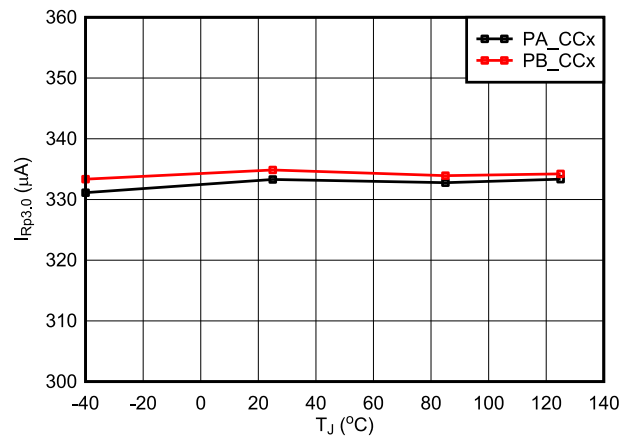

Figure 6-6. Strength of Cable Detect Current Source Advertising 3A

6.25 Typical Characteristics (continued)

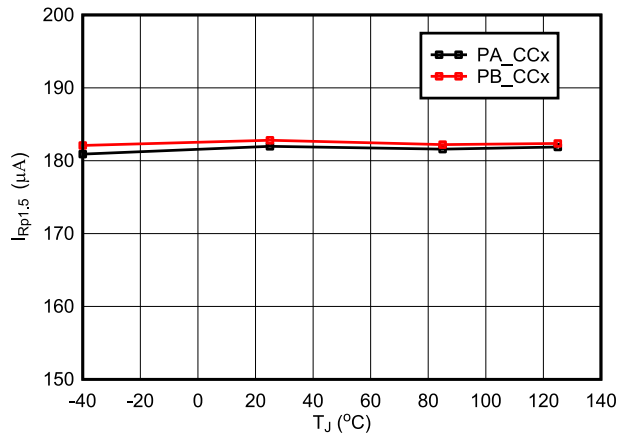

Figure 6-7. Strength of Cable Detect Current Source Advertising 1.5A

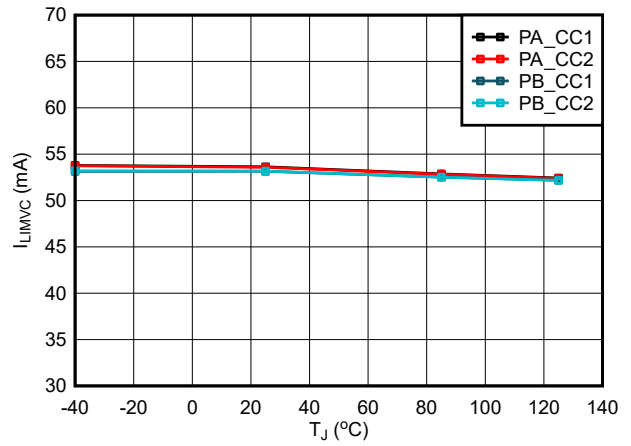

Figure 6-8. Current Limit for VCONN Switch

7 Parameter Measurement Information

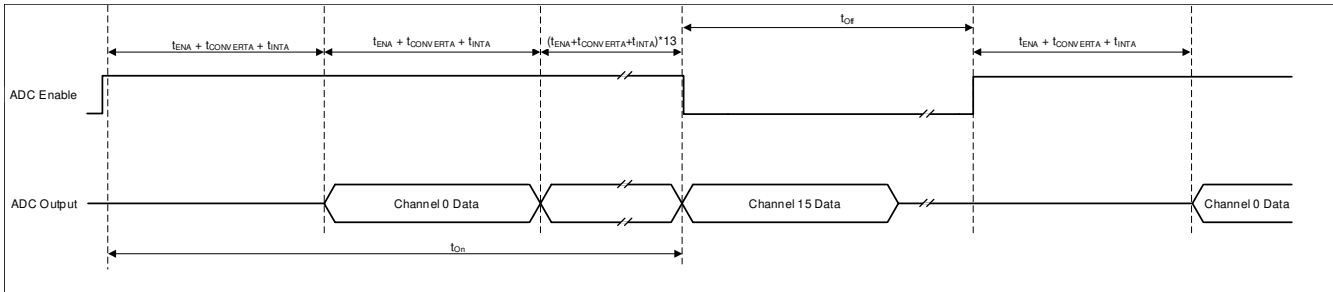

Figure 7-1. ADC Round Robin Conversion Timing

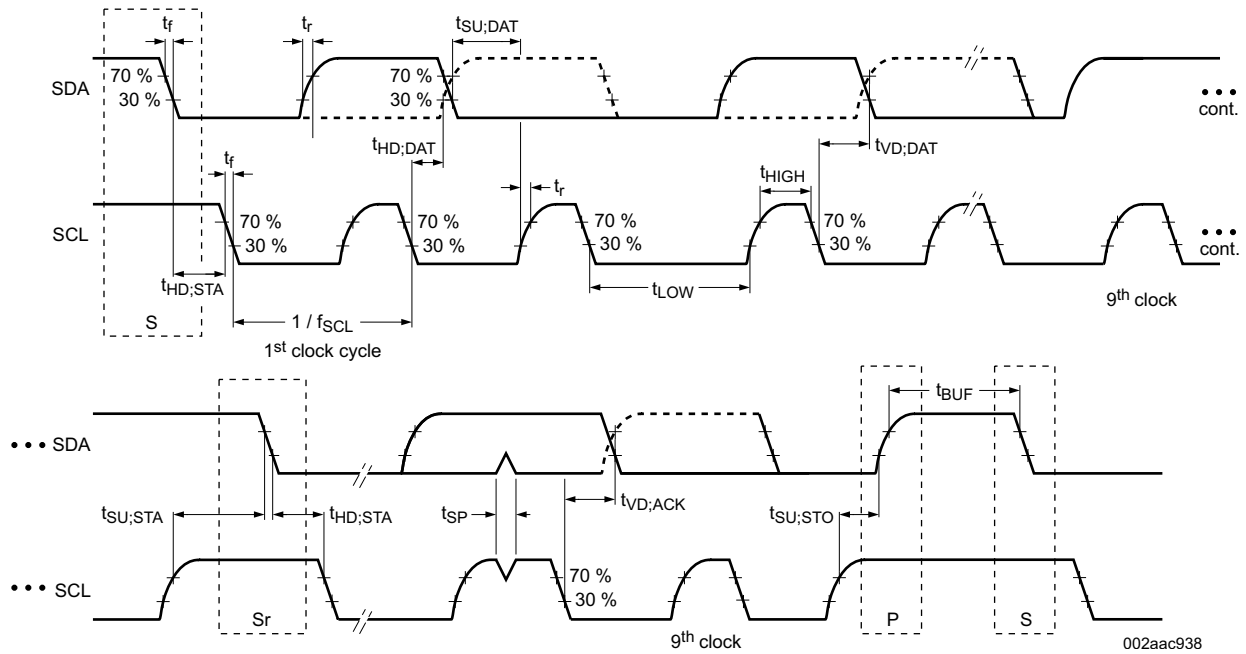

Figure 7-2. I²C Target Interface Timing

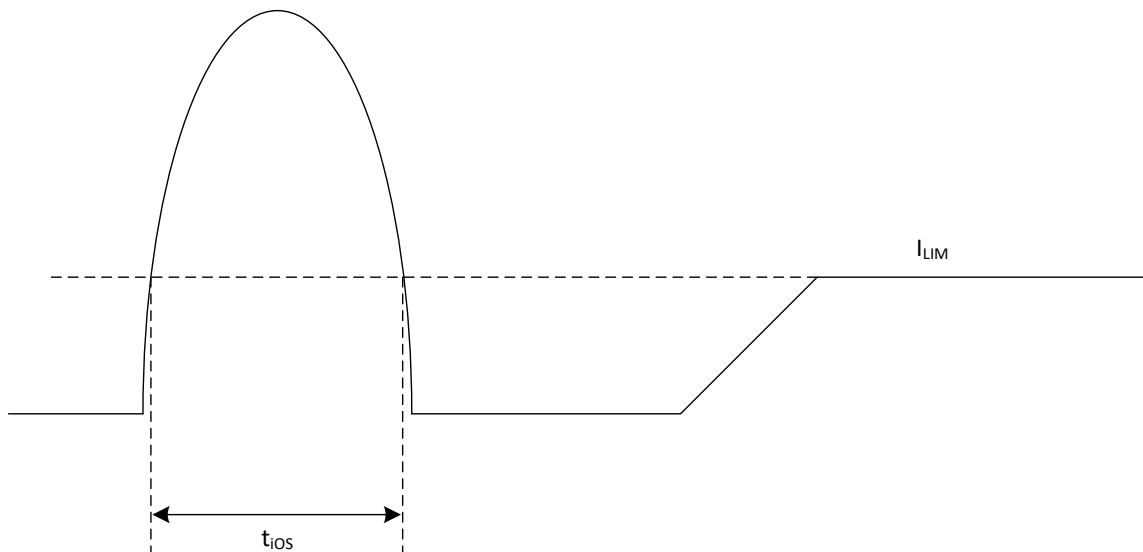

Figure 7-3. Short-Circuit Response Time for Internal Power Paths

8 Detailed Description

8.1 Overview

The TPS26742E-Q1 is a fully-integrated USB Type-C Source Power Delivery (USB-PD) management device providing cable plug and orientation detection for two USB Type-C connectors. The TPS26742E-Q1 communicates with the cable and another USB Type-C and PD device at the opposite end of the cable to negotiate power to be delivered. The TPS26742E-Q1 controls an external power supply (for example, DC/DC) for sourcing requested voltage and current to VBUS on the USB-C connector. The TPS26742E-Q1 has an internal LDO capable of delivering VCONN to the cable in order to read the eMarker information.

Each Type-C port controlled by the TPS26742E-Q1 is functionally identical and supports the full range of the USB Type-C and PD standards.

The TPS26742E-Q1 has many other features designed for automotive USB-C applications that are detailed in the following subsections.

- Power foldback
- Thermal foldback
- Flexible GPIOs
- System power sharing across multiple PD controllers
- Synchronizing output signals (Px_SYNC)
- Local interconnect network (LIN) support
- Liquid detection
- BC 1.2
- Pulse-width modulation (PWM)

8.2 Functional Block Diagram

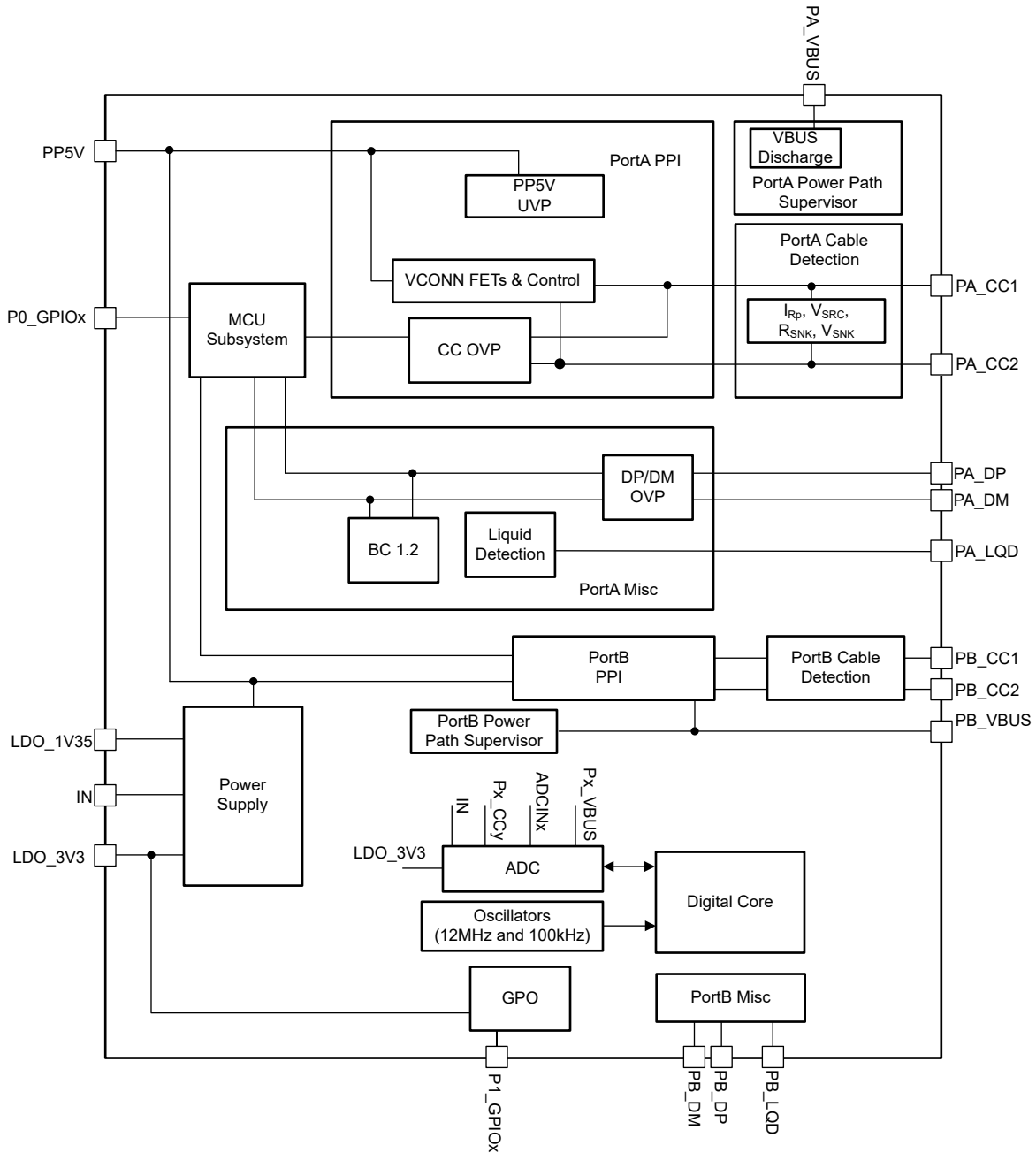

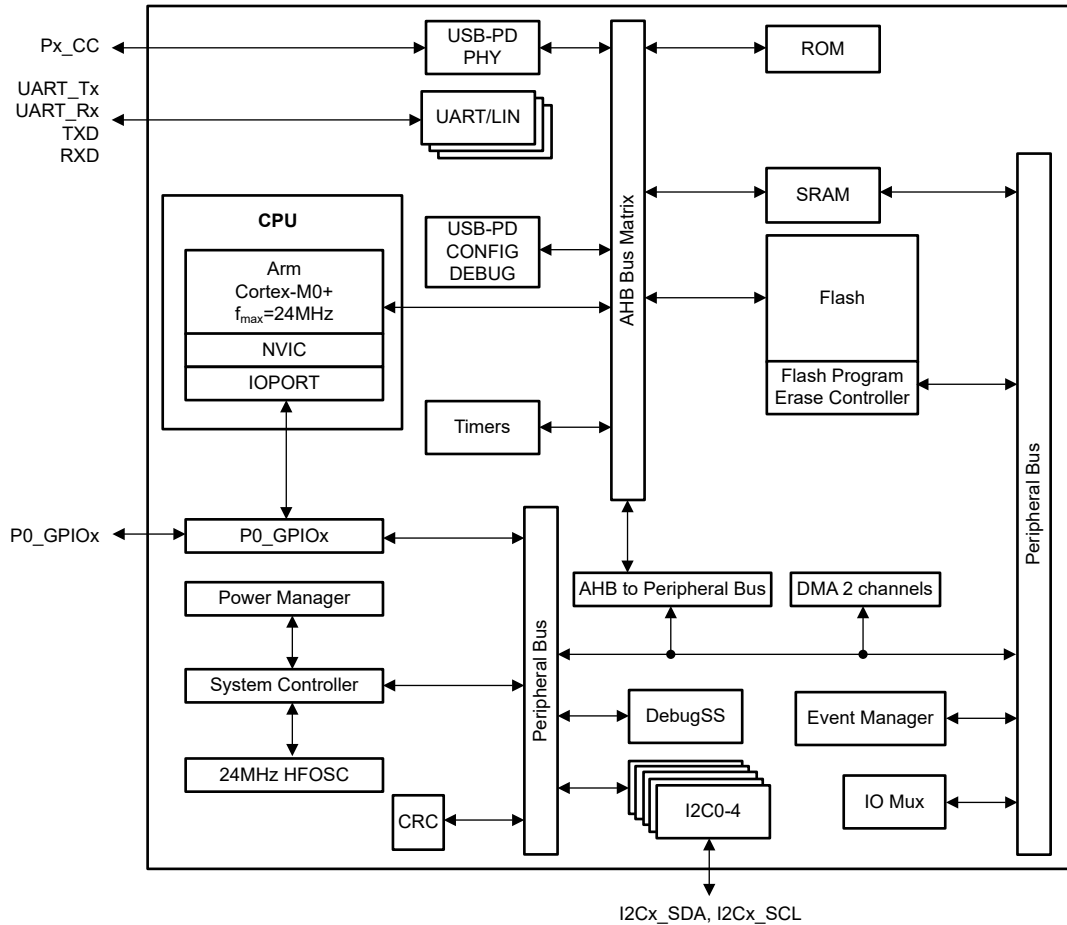

Figure 8-1. MCU Subsystem

8.3 Feature Description

8.3.1 Power Supply

The TPS26742E-Q1 power management block receives power and generates voltages to provide power to the TPS26742E-Q1 internal circuitry. These generated power rails are PP5V, LDO_3V3, and LDO_1V35. LDO_3V3 provides a low-power output. The internal LDO provides the supply for a low-power VCONN to read an eMarker. The power supply path is shown in [Figure 8-2](#).

When the PP5V rail is generated from the IN pin using the internal LDO there are two functional regions:

1. Functional Class A (ISO 16750-1) when the IN voltage is 4.5V or higher, the TPS26742E-Q1 has full functionality per the electrical characteristics.
2. Functional Class B (ISO 16750-1) when the IN voltage is above 3.5V and below 4.5V the TPS26742E-Q1 functions normally, but the limits given in the electrical characteristics are not guaranteed. Note that when IN falls below its UVLO a reset of the TPS26742E-Q1 is expected.

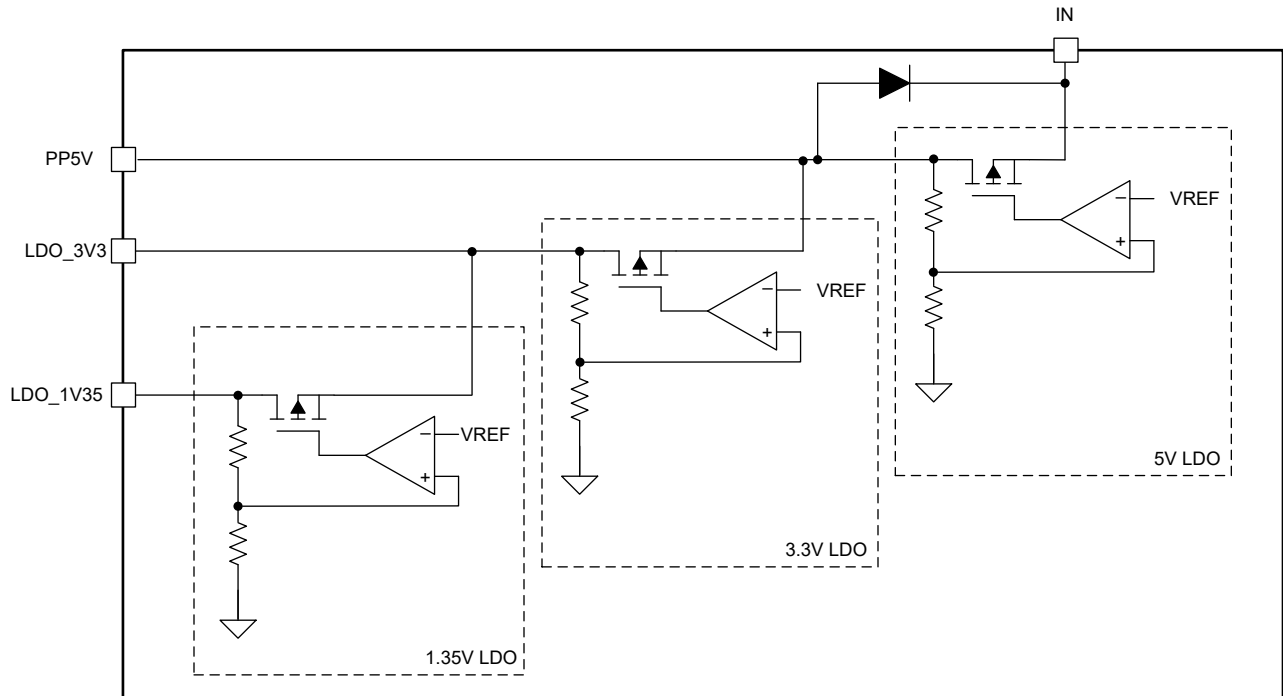

Figure 8-2. Power Supplies

8.3.1.1 Power-On and Supervisory Functions

A power-on reset (POR) circuit monitors each supply. This POR allows active circuitry to turn on only when a good supply is present.

8.3.2 Cable Plug and Orientation Detection

The following figure shows the plug and orientation detection block at each P_x_CC_y pin. Each pin has identical detection circuitry. Depending upon the mode, the TPS26742E-Q1 enables the appropriate termination (I_{Rp} , R_{SNK} , R_a , or none) and monitor the appropriate voltage thresholds via the Upper, Mid and/or Lower monitor to determine the state of each CC pin (SRC.Open, SRC.Rd, SRC.Ra, SNK.Rp, or SNK.Open). The states of each CC pin are used to implement the functionality described in the following subsections.

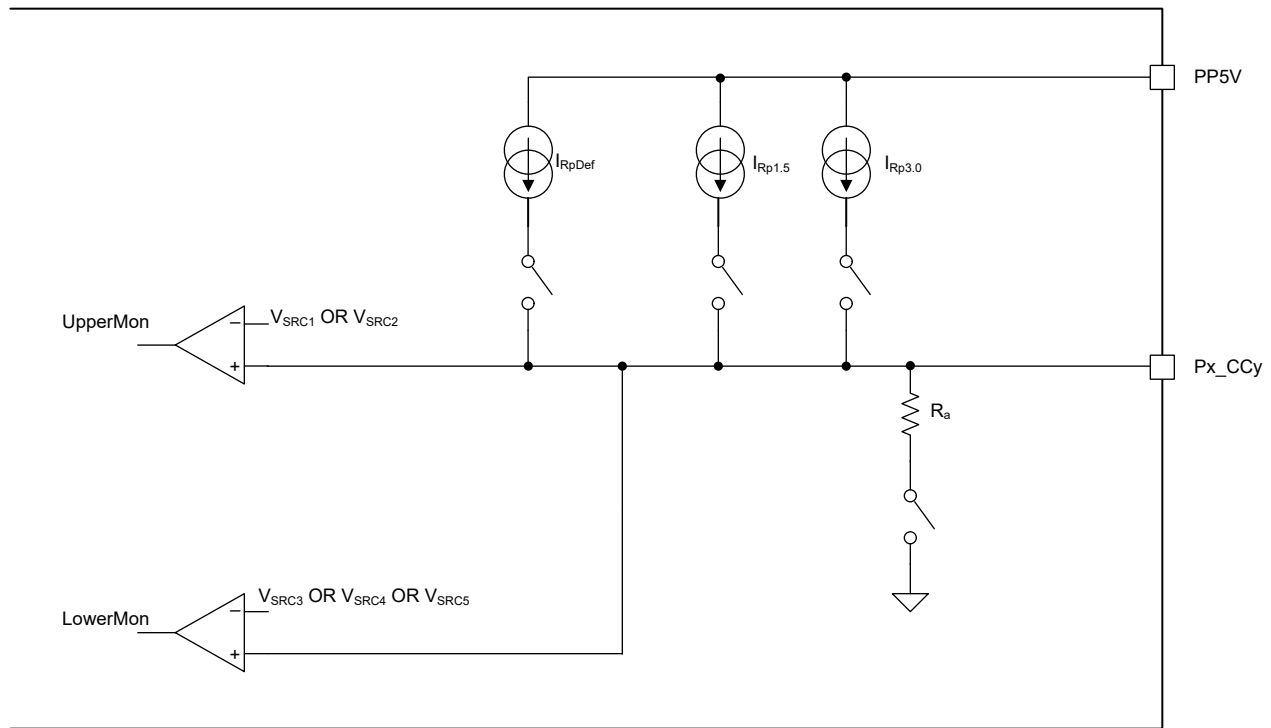

Figure 8-3. Plug and Orientation Detection Block

8.3.2.1 Configured as a Source

When configured as a Source, the TPS26742E-Q1 detects when a cable or a Sink is attached using the Px_CC1 and Px_CC2 pins. When in a disconnected state, the TPS26742E-Q1 monitors the voltages on these pins to determine what, if anything, is connected. See [USB Type-C Specification](#) for more information.

Table 8-1 shows the Cable Detect States for a Source. Figure 8-4 illustrates how the CC voltage thresholds are used to detect the various states.

Table 8-1. Cable Detect States for a Source

CC1	CC2	CONNECTION STATE	RESULTING ACTION
SRC.Open	SRC.Open	Nothing attached	Continue monitoring both CCy pins for attach. Power is not applied to VBUS or VCONN.
SRC.Rd	SRC.Open	Sink attached	Monitor CC1 for detach. Power is applied to VBUS. In some cases power is applied to VCONN.
SRC.Open	SRC.Rd	Sink attached	Monitor CC2 for detach. Power is applied to VBUS. In some cases power is applied to VCONN.
SRC.Ra	SRC.Open	Active Cable-No UFP attached	Monitor CC2 for a Sink attach and CC1 for cable detach. Power is not applied to VBUS or VCONN.
SRC.Open	SRC.Ra	Active Cable-No UFP attached	Monitor CC1 for a Sink attach and CC2 for cable detach. Power is not applied to VBUS or VCONN.
SRC.Ra	SRC.Rd	Active Cable-UFP Attached	Provide power on VBUS and VCONN (CC1) then monitor CC2 for a Sink detach. CC1 is not monitored for a detach.
SRC.Rd	SRC.Ra	Active Cable-UFP attached	Provide power on VBUS and VCONN (CC2) then monitor CC1 for a Sink detach. CC2 is not monitored for a detach.
SRC.Rd	SRC.Rd	Debug Accessory Mode attached	Sense either CCy pin for detach.
SRC.Ra	SRC.Ra	Corrosion Mitigation	Sense either CCy pin for detach.

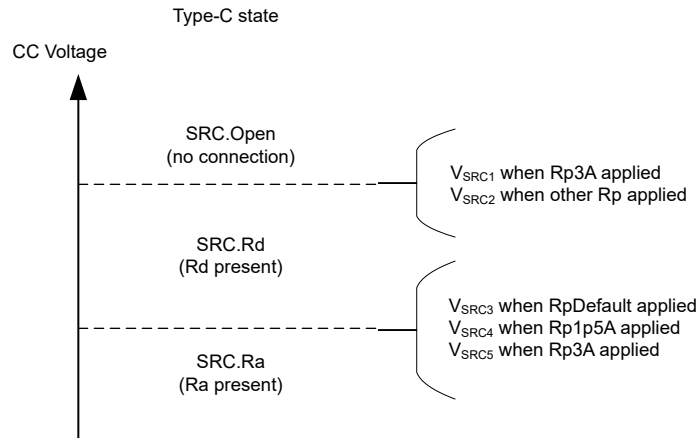

Figure 8-4. Illustration of Cable Detect Thresholds in Source Mode

When a TPS26742E-Q1 port is configured as a Source, a current $I_{Rp,Def}$ is driven out each CCy pin and each pin is monitored for different states. When a Sink is attached to the pin, the Sink applies a pull-down resistance of R_d to GND. The current $I_{Rp,Def}$, $I_{Rp3.0A}$, or $I_{Rp1.5A}$ is forced across the resistance R_d , generating a voltage at the CCy pin.

When the CCy pin connects to an active cable VCONN input, the pull-down resistance is different (R_a) leading to lower voltage on the CCy pin. The TPS26742E-Q1 recognizes the lower voltage as an active cable.

The voltage on CCy is monitored to detect a disconnection depending upon which R_p current source is active. When a connection is recognized and the voltage on CCy subsequently rises above the disconnect threshold for t_{CC} , the TPS26742E-Q1 detects a disconnection.

8.3.3 VCONN Power Path

The TPS26742E-Q1 features internal 5V VCONN sourcing power paths called P_x_VCONN as shown in [Figure 8-5](#). Each path contains programmable current clamping protection (I_{LIMVC}), overvoltage protection (OVP), UVLO protection, reverse-current protection (RCP) and overtemperature protection (OTSD).

When the P_x_VCONN switch is enabled, it turns on with slew-rate control per the parameters t_{VCRISE} and t_{VCON} .

When the P_x_VCONN switch is disabled, it turns off with slew-rate control per the parameters t_{VCFALL} and t_{VCOFF} . The turn off times for fault events are specified separately:

- RCP fault event: t_{VC_RCP}
- PP5V OVP fault event: t_{VC_OVP}
- PP5V UVLO fault event: t_{VC_UVLO}

Using the eMarker-only setting, the internal LDO from the IN pin supplies sufficient current to the PP5V pin.

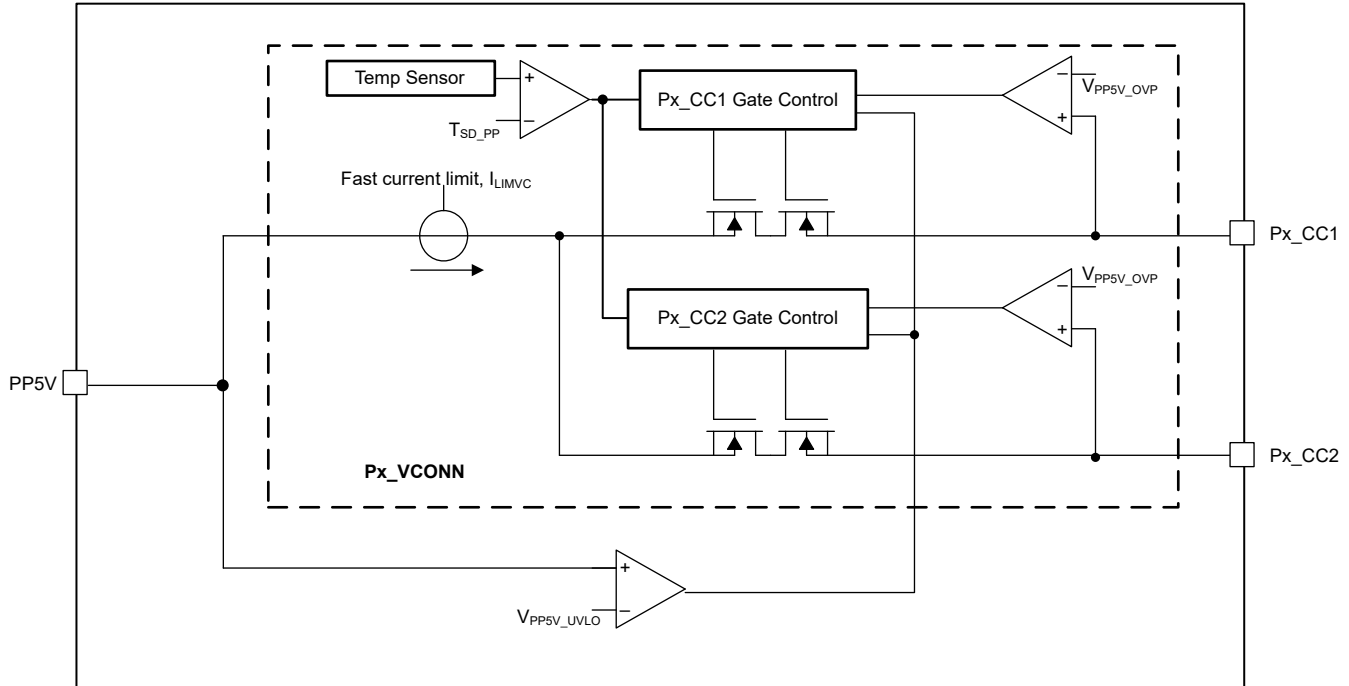

Figure 8-5. Px_VCONN Power Path

8.3.3.1 Current Clamp

When enabled and providing VCONN power the TPS26742E-Q1 Px_VCONN power switch clamps the current to I_{LIMVC} . When the current through the Px_VCONN switch exceeds I_{LIMVC} , the current clamping circuit activates within t_{IOS_VCONN} and the switch behaves as a constant current source.

8.3.3.2 Px_VCONN Local Overtemperature Shut Down (OTSD)

When Px_VCONN clamps the current, the temperature of the switch begins to increase. When the local temperature sensor for Px_VCONN detects that $T_J > T_{SD_PP}$ the Px_VCONN switch is disabled within t_{VCOFF} . The port then enters the USB Type-C ErrorRecovery state.

8.3.3.3 Px_VCONN OVP

There is an OVP comparator at the output of Px_VCONN (that is the Px_CC1 or Px_CC2 pin) with a fixed threshold. If an OVP is detected ($V_{Px_CCy} > V_{PP5V_OVP}$) while Px_VCONN is enabled, then Px_VCONN is disabled within t_{VC_OVP} and the port enters into the Type-C ErrorRecovery state.

8.3.3.4 Px_VCONN UVLO

If the PP5V pin voltage falls below its undervoltage lock out threshold (V_{PP5V_UVLO}) while Px_VCONN is enabled, then Px_VCONN is disabled within t_{VC_UVLO} and the port enters into the Type-C ErrorRecovery state.

8.3.3.5 Px_VCONN RCP

If reverse current is detected, $(V_{Px_CCy} - V_{PP5V}) > V_{VC_RCP}$, while the Px_VCONN path is enabled, then it is disabled within t_{VC_RCP} . If the RCP condition clears, then the Px_VCONN path is automatically enabled within t_{VCON} .

8.3.4 USB-PD Physical Layer

Figure 8-6 shows the USB PD physical layer block surrounded by a simplified version of the analog plug and orientation detection block. This block is duplicated for the second TPS26742E-Q1 port.

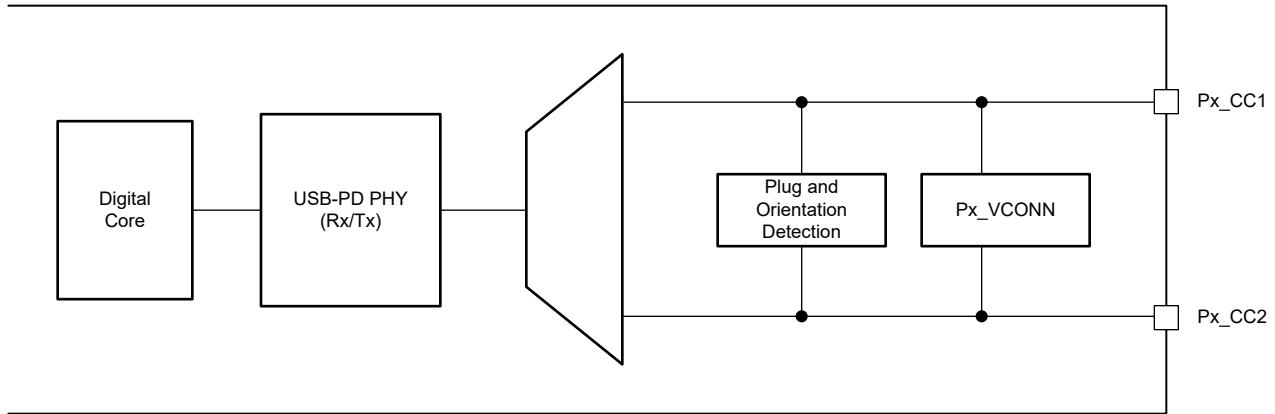

Figure 8-6. USB-PD Physical Layer and Simplified Plug and Orientation Detection Circuitry

USB-PD messages are transmitted in a USB Type-C system using BMC signaling. The BMC signal is output on the same pin (Px_CC1 or Px_CC2) that is DC biased due to the Rp (or Rd) cable attach mechanism.

8.3.4.1 USB-PD Encoding and Signaling

Figure 8-7 illustrates the high-level block diagram of the baseband USB-PD transmitter. Figure 8-8 illustrates the high-level block diagram of the baseband USB-PD receiver.

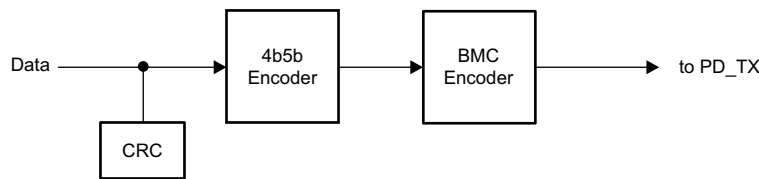

Figure 8-7. USB-PD Baseband Transmitter Block Diagram

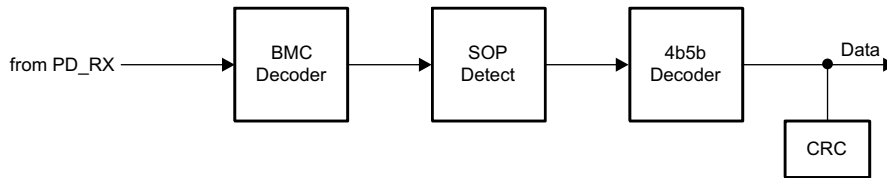

Figure 8-8. USB-PD Baseband Receiver Block Diagram

8.3.4.2 USB-PD Bi-Phase Marked Coding

The USB-PD physical layer implemented in the TPS26742E-Q1 is compliant to the *USB-PD Specifications*. The encoding scheme used for the baseband PD signal is a version of Manchester coding called Biphas Mark Coding (BMC). In this code, there is a transition at the start of every bit time and there is a second transition in the middle of the bit period when a 1 is transmitted. This coding scheme is nearly DC balanced with limited disparity (limited to 1/2 bit over an arbitrary packet, so a very low DC level). Figure 8-9 illustrates Biphas Mark Coding.

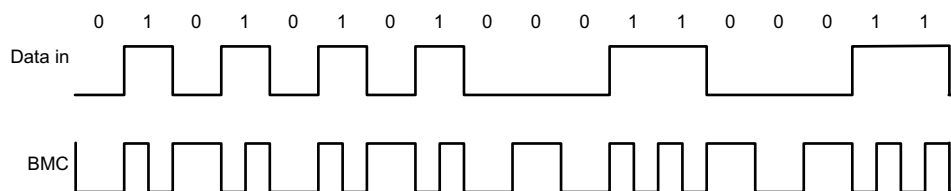

Figure 8-9. Biphas Mark Coding Example

The USB PD baseband signal is driven onto the Px_CC1 or Px_CC2 pin with a tri-state driver. The tri-state driver is slew rate controlled to limit coupling to D+/D- and to other signal lines in the Type-C fully featured cables. When sending the USB-PD preamble, the transmitter starts by transmitting a low level. The receiver at the other end tolerates the loss of the first edge. The transmitter terminates the final bit by an edge to enable the receiver to clock the final bit of EOP.

8.3.4.3 USB-PD BMC Transmitter

The TPS26742E-Q1 transmits and receives USB-PD data over one of the Px_CC1 or Px_CC2 pins for a given CC pin pair (one pair per USB Type-C port). The Px_CC1 or Px_CC2 pins are also used to determine the cable orientation and maintain the cable and device attach detection. Thus, a DC bias exists on the Px_CCy pin. The transmitter driver overdrives the Px_CCy DC bias while transmitting, but returns to a Hi-Z state allowing the DC voltage to return to the Px_CCy pin when not transmitting. Depending upon the polarity of the cable attachment, either Px_CC1 or Px_CC2 is used for transmitting and receiving, during a given connection only the one that mates with the CC pin of the plug is used; so there is no dynamic switching between Px_CC1 and Px_CC2. Figure 8-10 shows the USB-PD BMC TX and RX driver block diagram.

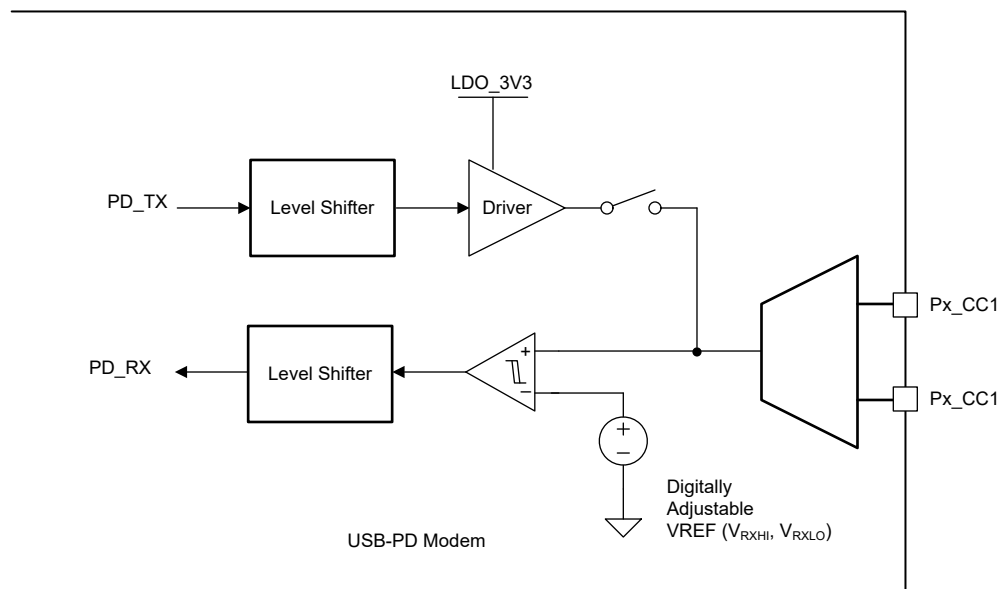

Figure 8-10. USB-PD BMC TX/Rx Block Diagram

Figure 8-11 shows the transmission of the BMC data on top of the DC bias. Note, the DC bias shown is just an example. The actual DC bias varies between the minimum and maximum threshold for detecting a Sink attach.

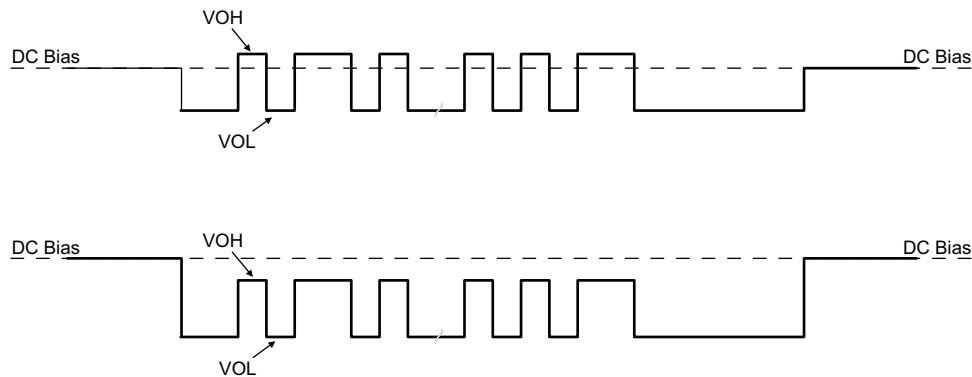

Figure 8-11. TX Driver Transmission with DC Bias

The transmitter drives a digital signal onto the Px_CC1 or Px_CC2 pins. The signal peak, V_{TXHI} , is set to meet the TX masks defined in the [USB-PD Specifications](#). Note that the TX mask is measured at the far-end of the cable.

When driving the line, the transmitter driver has an output impedance of Z_{DRIVER} . Z_{DRIVER} is determined by the driver resistance and the shunt capacitance of the source and is frequency dependent. Z_{DRIVER} impacts the noise ingress in the cable.

Figure 8-12 shows the simplified circuit determining Z_{DRIVER} , specified so that noise at the receiver is bounded.

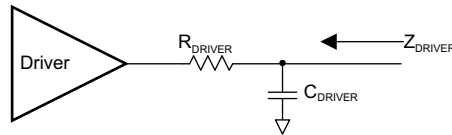

Figure 8-12. ZDRIVER Circuit

8.3.4.4 USB-PD BMC Receiver

The receiver block of the TPS26742E-Q1 is designed to receive a signal that follows the allowed Rx masks defined in the USB PD specification. The receive thresholds and hysteresis come from this mask.

Figure 8-13 shows an example of a multi-drop USB-PD connection (only the CC wire). This connection has the typical Sink (device) to Source (host) connection, and also includes cable USB-PD Tx/Rx blocks. Only one system transmits at a time, all other systems are Hi-Z (Z_{BMCRX}). The [USB-PD Specification](#) also specifies the capacitance on the wire, as well as a typical DC bias setting circuit for attach detection.

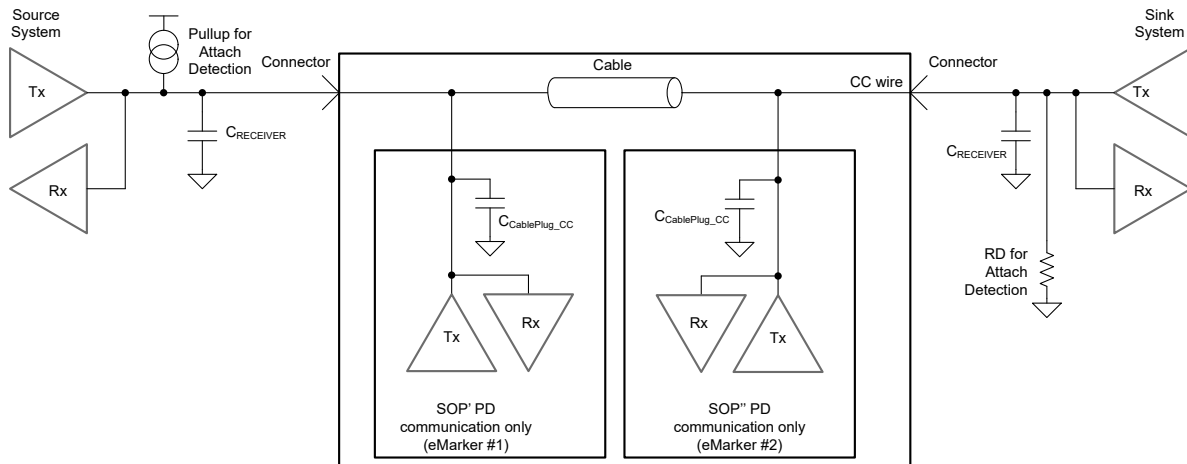

Figure 8-13. Example USB-PD Multi-Drop Configuration

8.3.4.5 Squelch Receiver

The TPS26742E-Q1 has a squelch receiver to monitor for the bus idle condition as defined by the USB PD specification.

8.3.5 DBG_SDA, DBG_SCL and DP/DM Overview

The pins that have Px_DP and Px_DM pin functions also have P1_GPOx pin functions. The PA_DP and DBG_SCL pin functions are on the same pin. The PA_DM and DBG_SDA pin functions are on the same pin. It is not possible to use multiple pin functions at the same time. For the DBG_SCL and DBG_SDA pin functions, choose either the SBUX pins or the D+/D- pins on the connector. This section shows the overall diagrams, and following subsections provide more details on each.

- The DBG_SCL and DBG_SDA pin functions provide access to I2C4 and UART from the MCU sub-system. The I2C4 is configurable to be used for updating the flash (see [Section 8.3.5.1](#)).
- DP/DM charging functionality (see [Section 8.3.5.2](#)).

The following sub-sections provide more details.

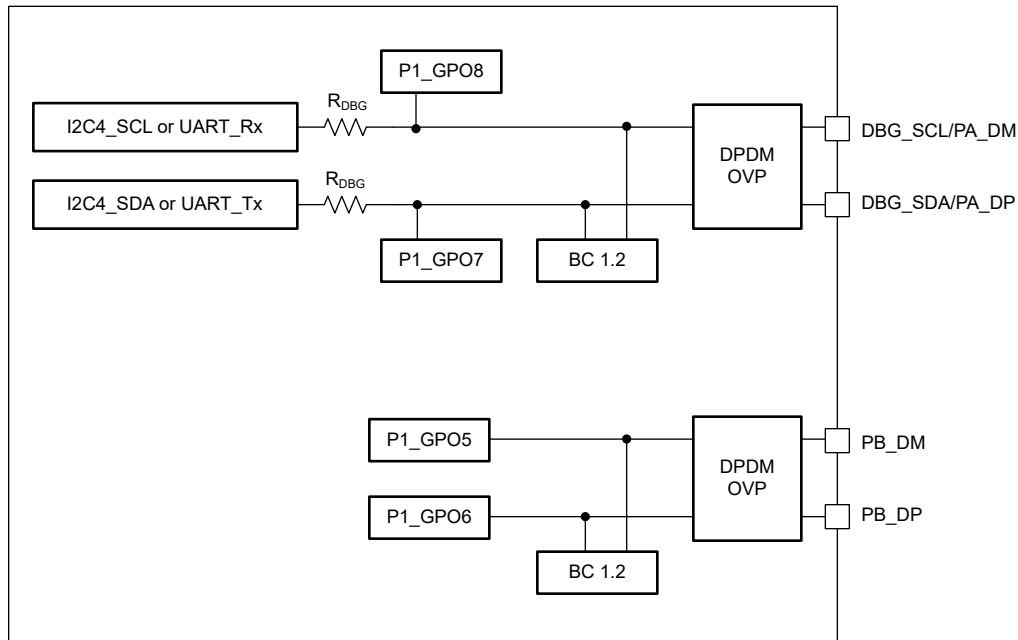

Figure 8-14. DP DM Hardware Functionality

8.3.5.1 Closed Chassis Debugging and Updating Flash

The DBG_SDA and DBG_SCL pins provide access to I2C4 or UART via pin(s) on the USB-C connector. The I2C4 access provides capability to update the flash memory, but also provides a way to monitor or control TPS26742E-Q1 for debugging. Disable this feature in the device configuration to block access to I2C4.

The TPS26742E-Q1 has a configuration option to output debug UART messages on the DBG_SDA pin instead of being used for I2C4 access.

Note

Access to I2C4 is not available unless the TPS26742E-Q1 has been previously loaded with firmware that enables this feature.

8.3.5.1.1 I2C4 Access For Closed-chassis Debugging

If the PA_DM and PA_DP pin functions are required, then DBG_SDA and DBG_SCL are also attached to the D+/D- pins on the connector. In other cases, connecting the DBG_SDA/SCL pin functions to the SBU1/SBU2 pins is another option. Both options are shown in the below figures. The TPS26742E-Q1 disables I2C4 until a debug accessory is detected (5.1kΩ on both CC pins) to avoid interfering with any other signaling.

The external debug accessory used to connect to I2C4 provides the I2C pullups as illustrated in the following figures. [Figure 8-15](#) illustrates using the D+/D- pins for I2C4 access.

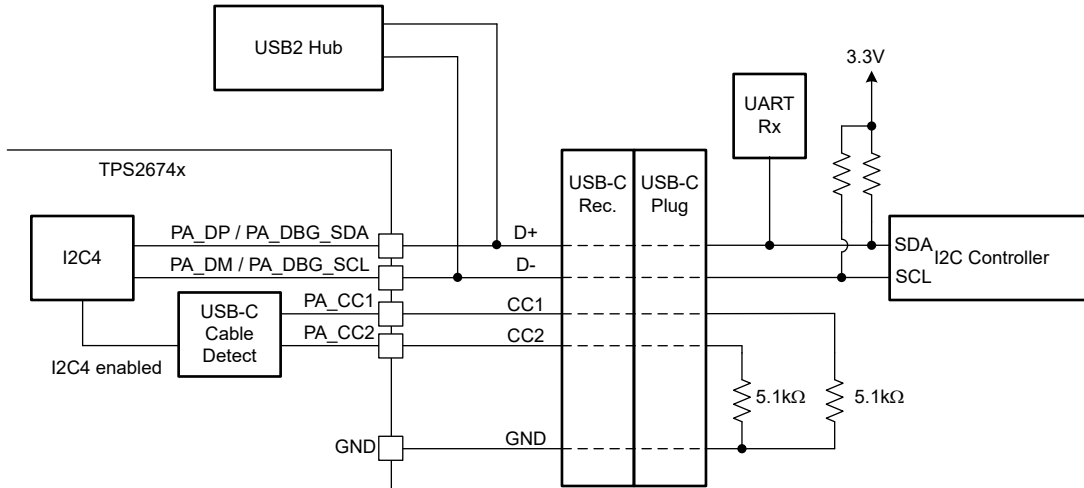

Figure 8-15. Connecting I2C4 to a Debug Accessory

Figure 8-16 shows the same configuration when connecting to a USB2 device instead of a debug accessory. In this case I2C4 remains disabled because the TPS26742E-Q1 only sees a 5.1kΩ resistor on one CC pin (since the cable only has one CC wire). In this case I2C4 remains disabled to allow D+/D- signaling.

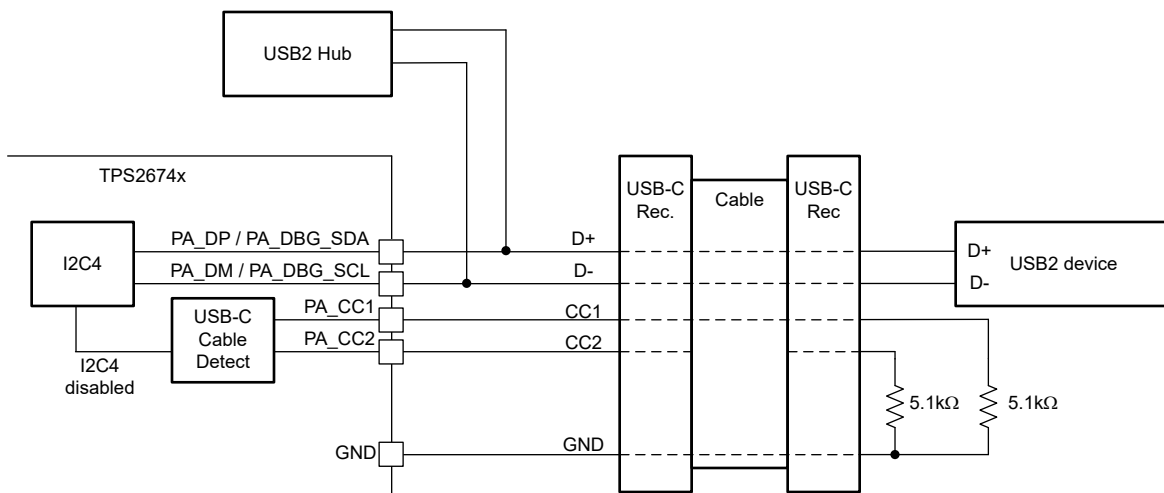

Figure 8-16. I2C4 Does Not Interfere with D+/D- Signaling

Figure 8-17 and Figure 8-18 illustrate using SBU1 and SBU2 for I2C4 access. Figure 8-17 shows connecting to a debug accessory and Figure 8-18 shows connecting to a DP source. The concept is the same as for the D+/D- pins described above.

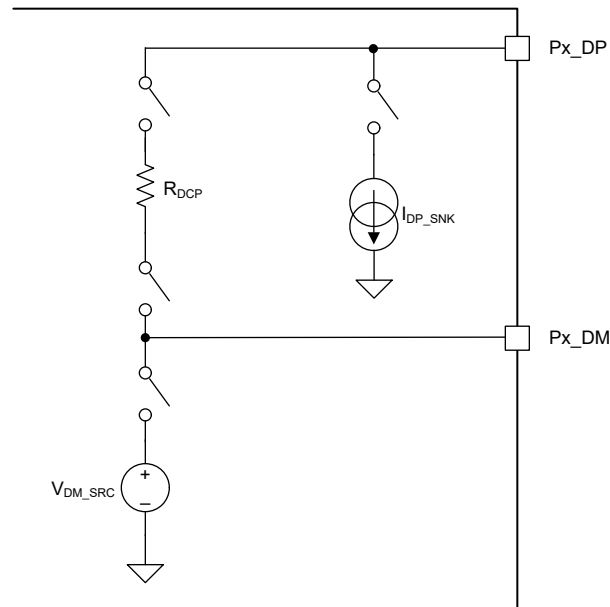

Figure 8-19. BC1.2 Legacy Charging Diagram

8.3.5.2.1 Charging Downstream Port (CDP) Mode

A CDP is a USB port that follows USB BC1.2 and supplies a minimum of 1.5A per port. A CDP provides power and meets the USB 2.0 requirements for device enumeration. The difference between CDP and SDP is the host-charge handshaking logic that identifies this port as a CDP. A CDP is identifiable by a compliant BC1.2 portable device and allows for additional current draw by the portable device.

The CDP handshaking process occurs in two steps. During step one, the portable device outputs a nominal 0.6V output on the DP line and reads the voltage input on the DM line. The portable device detects the connection as an SDP if the voltage is less than the nominal data-detect voltage of 0.3V. The portable device detects the connection as a CDP if the DM voltage is greater than the nominal data detect voltage of 0.3V and optionally less than 0.8V.

The second step is necessary for portable equipment to determine whether the equipment is connected to a CDP or a DCP. The portable device outputs a nominal 0.6V output on the DM line and reads the voltage input on the DP line. The portable device concludes the equipment is connected to a CDP if the data line being read remains less than the nominal data detects voltage of 0.3V. The portable device concludes it is connected to a DCP if the data line being read is greater than the nominal data detect voltage of 0.3V.

8.3.5.2.2 Dedicated Charging Port (DCP) Mode

A DCP only provides power and does not support data connection to an upstream port. Another way to implement the DCP functionality without using the Px_DP and Px_DM pins is to short the D+ and D- pins together near the USB-C connector. That leaves the Px_DP and Px_DM pins available for other functions in the system.

8.3.6 Liquid Detection

The TPS26742E-Q1 provides a Px_LQD pin for liquid detection. When connected to an appropriate pin on the USB-C receptacle it performs liquid detection. In most cases it is best to connect to either SBU1 or SBU2 as allowed by the USB-C specification since those are high-Z until needed for other functions such as Alternate Mode or USB4 mode.

The concept behind the liquid detection is to send a current pulse on the Px_LQD pin and measure how long it takes the pin voltage to reach a threshold. Liquids have capacitive and resistive components that slow the rise of the voltage and limit its maximum value. Many factors affect the rise time so tunability is designed into the application.

In order to limit the maximum Px_LQD voltage a weak pulldown resistor is used (R_{LQD}). Different pulldown options are available to pair with different current source strengths (I_{LQD}). The intention is to use liquid detection with a maximum voltage of approximately 2.0V. So the specifications are written around that use case. A secondary maximum pin voltage option is 0.4V in case there are clamps on the pins used for liquid detection.

Figure 8-20 illustrates the concept. At time 0, a current pulse is applied to the Px_LQD pin. Depending on the selected I_{LQD} and R_{LQD} there is a maximum expected pin voltage of V_{MAX} . Even in a dry receptacle the rise time is slowed by capacitance, but liquids prone to cause corrosion have a slower rise time. A threshold (V_{LQD}) is chosen so that a dry receptacle (or a receptacle with distilled water) is *not* detected as a fault condition. The $T_{RISE}(\text{Liquid})$ threshold is programmable in FW up to ~5ms. If the rise time exceeds $T_{RISE}(\text{Liquid})$ then actions are taken to mitigate corrosion due to the presence of liquid. Once liquid is detected, it is rechecked periodically until no liquid is detected before resuming normal operation.

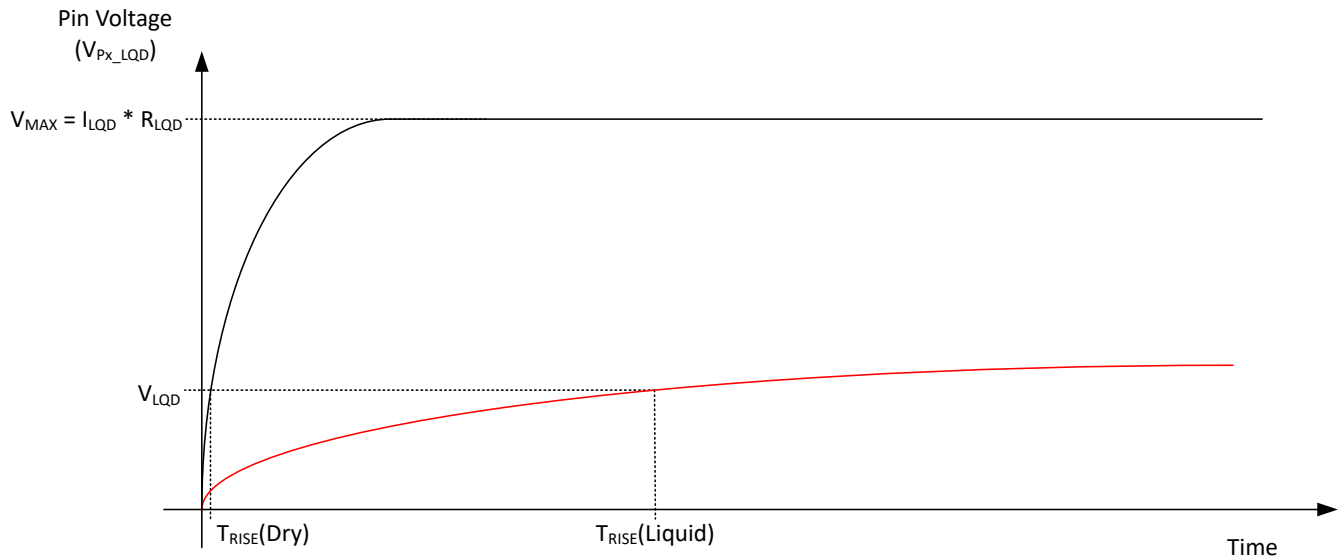

Figure 8-20. Pin Voltage Illustration

8.3.7 Local Interconnect Network (LIN) Support

The TPS26742E-Q1 supports communication using the LIN protocol as an alternative to I2C for controlling or monitoring power policy or other features. The TXD pin function is an output from TPS26742E-Q1, and the RXD pin function is an input into the TPS26742E-Q1.

Note

If the TXD from multiple TPS26742E-Q1 are connected as shown in the following diagram, configure the P0_GPIOx pins as open-drain.

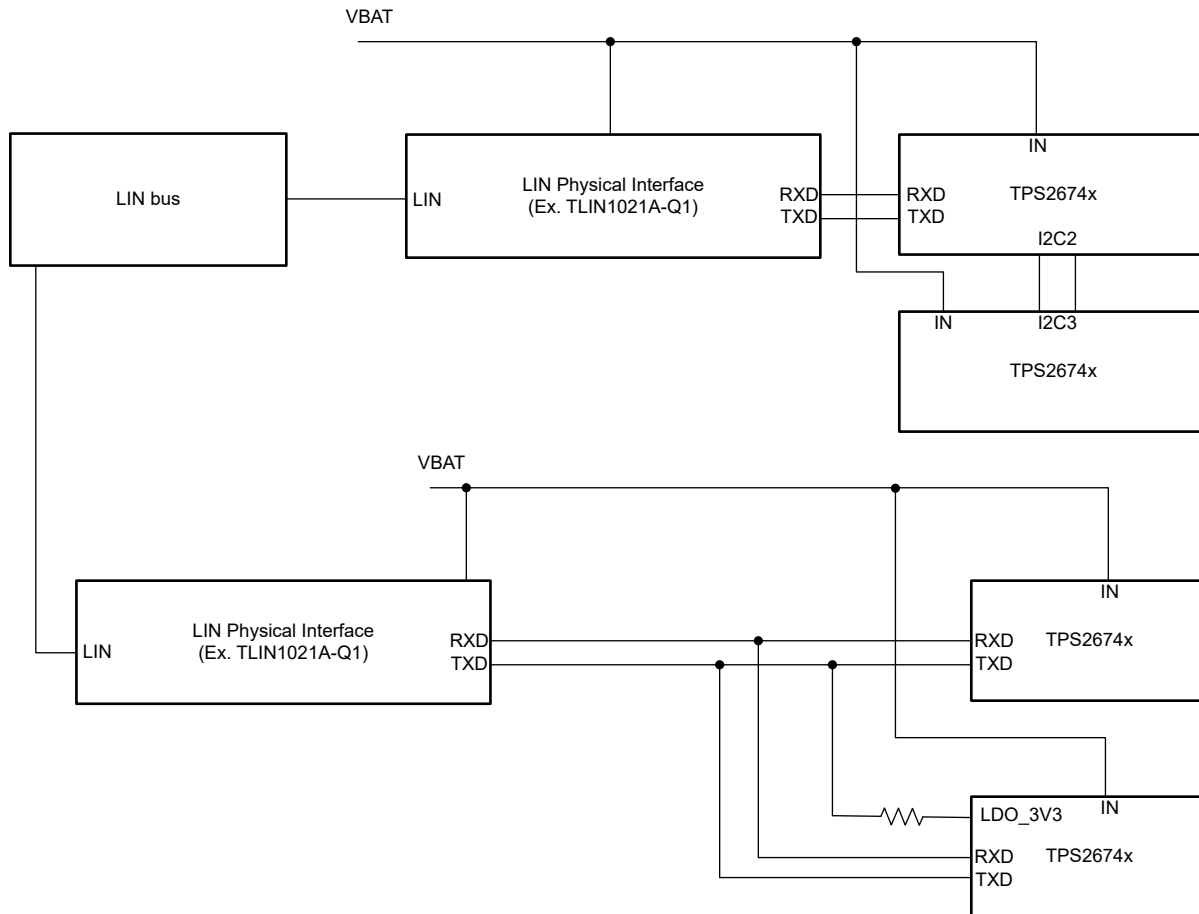

Figure 8-21. Example of Connecting to a LIN Bus

8.3.8 Thermal Shutdown

The TPS26742E-Q1 features a central thermal shutdown as well as independent thermal sensors for each internal power path. The central thermal shutdown monitors the overall temperature of the die and disables all functions except for supervisory circuitry when die temperature goes above a rising temperature of T_{SD} . When the temperature falls below the threshold and clears the hysteresis the device resumes normal operation.

Each power path has a thermal shutdown monitor. When the temperature of a power-path exceeds T_{SD_PP} the associated Px_VCONN is disabled. When the temperature falls below the threshold and clears the hysteresis the power paths resume normal operation.

8.3.9 ADC

The TPS26742E-Q1 ADC is shown in [Figure 8-22](#). The ADC is a successive approximation ADC. The input to the ADC is an analog input mux that supports multiple inputs from various voltages and currents in the device. The output from the ADC is available to be read via I²C and is also an input for the automatic ADC monitor circuits.

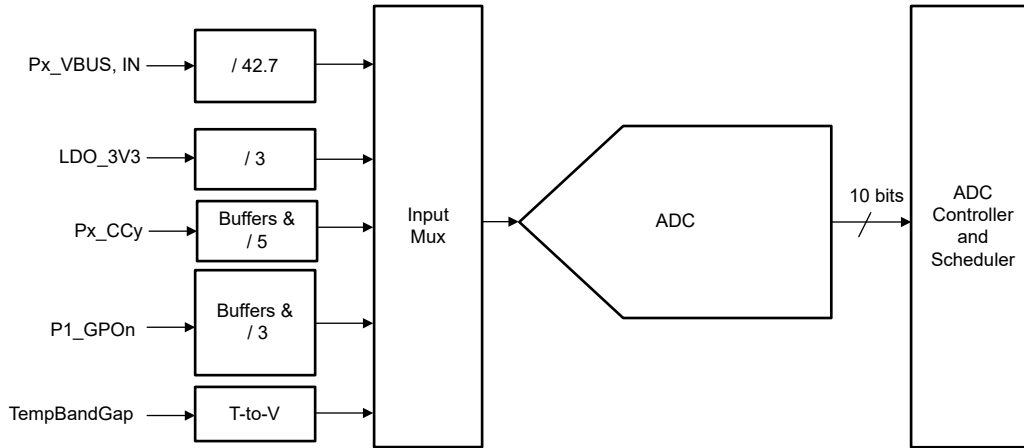

Figure 8-22. SAR ADC

8.3.9.1 ADC Divider Ratios

The ADC voltage inputs are each divided down to the full-scale input of 1.2V.

The following table shows the divider ratios for each ADC input.

Table 8-2. ADC Inputs

CHANNEL	SIGNAL	TYPE	LSB	DIVIDER RATIO
0	LDO_3V3	Voltage	3.52mV	3
1	Reserved			
2	P1_GPO0	Voltage	3.52mV	3
3	P1_GPO1	Voltage	3.52mV	3
4	P1_GPO2	Voltage	3.52mV	3
5	P1_GPO3	Voltage	3.52mV	3
6	BandGapTemp	Temperature		N/A
7	IN	Voltage	50mV	42.7
8-11	Reserved			
12	P1_GPO7	Voltage	3.52mV	3
13	P1_GPO8	Voltage	3.52mV	3
14	P1_GPO6	Voltage	3.52mV	3
15	P1_GPO5	Voltage	3.52mV	3
16	PA_VBUS	Voltage	50mV	42.7
17	PA_CC1	Voltage	5.86mV	5
18	PA_CC2	Voltage	5.86mV	5
19-23	Reserved			
24	PB_VBUS	Voltage	50mV	42.7
25	PB_CC1	Voltage	5.86mV	5
26	PB_CC2	Voltage	5.86mV	5
27-31	Reserved			

8.3.10 VIN Power Foldback

When the voltage at the IN pin is low and the external DC/DC is boosting to a higher voltage the system is prone to overheating. The TPS26742E-Q1 has the capability to monitor the IN voltage and reduce the VBUS output power to reduce power loss and avoid overheating.

8.3.11 Thermal Foldback

The TPS26742E-Q1 has the capability to measure system temperature and adjust the output power to each USB-C port to reduce temperature if necessary. To accurately sense system temperature connect an NTC to a P1_GPOx pin that has an ADC input as shown in the following figure.

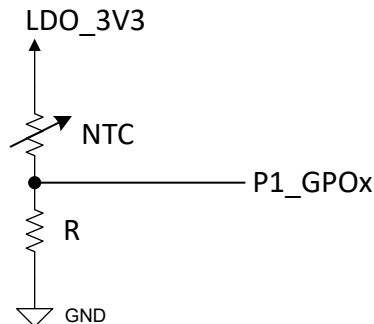

Figure 8-23. Example of Using an NTC to Sense Temperature

8.3.12 DisplayPort Hot-Plug Detect (HPD)

The TPS26742E-Q1 supports the DisplayPort over USB Type-C as a DP source or DP sink. The TPS26742E-Q1 supports the HPD converter functions on P0_GPIOx pins. The PD messaging events are translated into high or low on the corresponding HPD pin in a DisplayPort transmitter system. Conversely, a DisplayPort receiver system translates high or low status on the transmitted HPD pin PD messages.

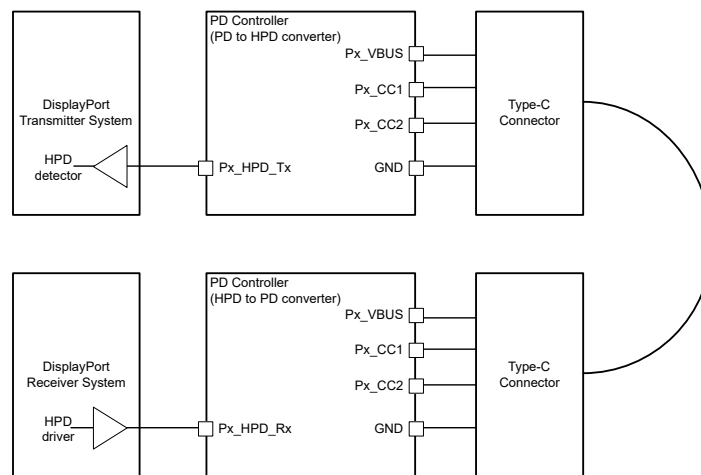

Figure 8-24. Illustration of How a PD-to-HPD Converter Passes the HPD Signal Along in a DisplayPort System

8.3.13 General GPIO

The TPS26742E-Q1 has groups of GPIO pins labeled P1_GPOx, and P0_GPIOx with each group having specific properties summarized in the table below. The following subsections describe the functionality of each group in more detail. GPIO/GPO pins are capable of being mapped to USB Type-C, USB PD, and application-specific events to control other ICs, interrupt a host processor, or receive input from another IC.

Table 8-3. Comparison of GPIO/GPO Types

	P0_GPIOx	P1_GPOx	P2_GPOx⁽¹⁾
Type	Push-pull or open-drain	Push-pull or open-drain	Open-drain
Max voltage	V _{LDO_3V3}	V _{LDO_3V3}	5.5V
Output supply	LDO_3V3	LDO_3V3	N/A
weak pull-up	40k	100k	N/A
weak pull-down	40k	100k	N/A
Input supply reference	LDO_3V3	LDO_3V3	N/A
ADC input	No	Yes for some pins.	

(1) These pin functions are not available on all devices. Check the pin list.

8.3.13.1 P0_GPIOx

The following figure shows the GPIO I/O buffer for P0_GPIOx pins.

The following table lists functionalities of each IO. There are certain mux functions available for assignment to multiple P0_GPIOx pins, but only one at a time. These mux options provide flexibility to select the set of mux functions needed in a particular system.

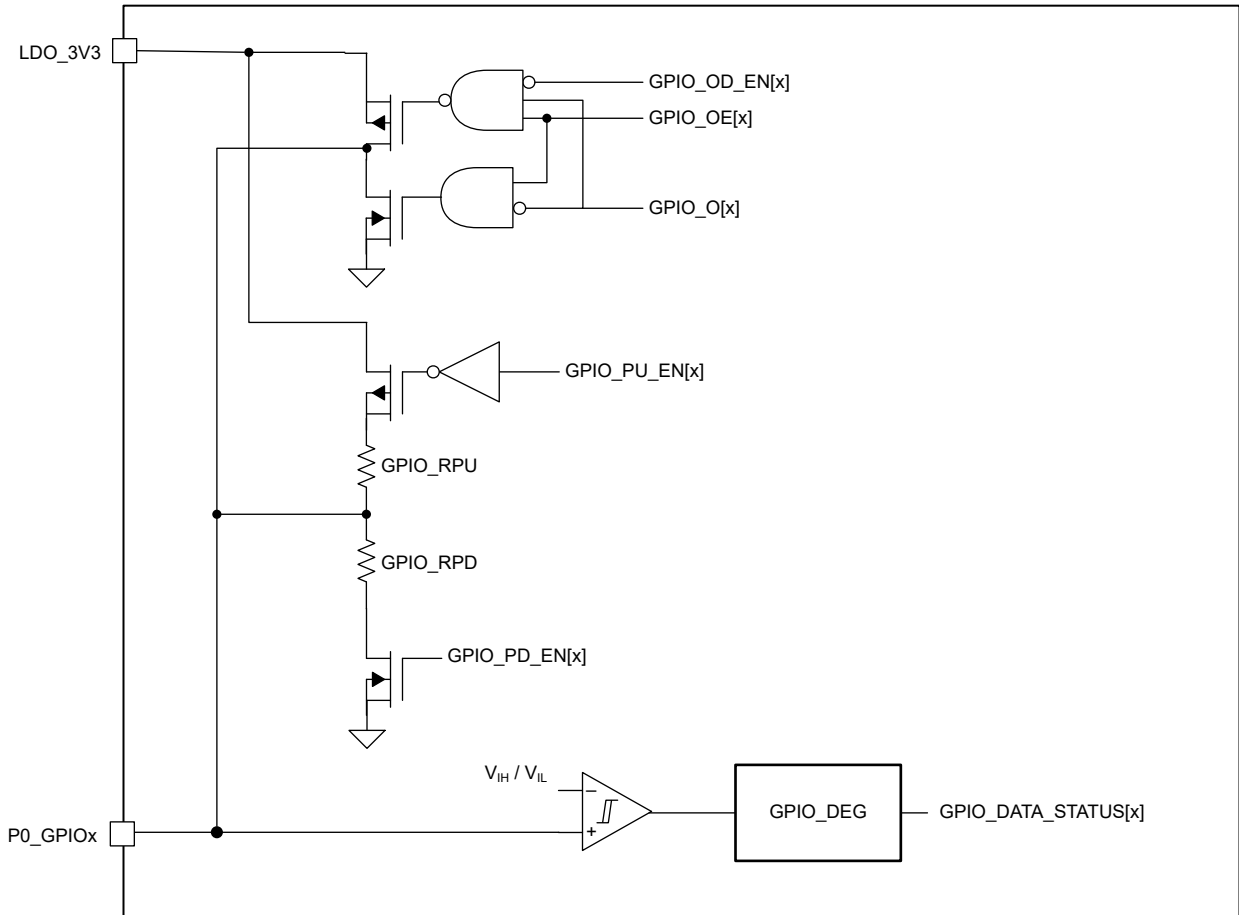

Figure 8-25. P0_GPIOx Buffer Diagram

Table 8-4. P0_GPIOx Functionality Table

Pin Name	Primary Muxed Functionality	Other Available Options
P0_GPIO0	I2C3_SCL	I2C2_SCL, PB_PWM
P0_GPIO1	PB_SYNC	I2C2_SDA, I2C3_SDA
P0_GPIO2		
P0_GPIO3	PA_PWM	UART_DBG_Tx ⁽²⁾
P0_GPIO4	I2C1_SCL	TXD ⁽¹⁾
P0_GPIO5	I2C1_SDA	RXD ⁽¹⁾
P0_GPIO6	PA_SYNC	UART_DBG_Tx ⁽²⁾
P0_GPIO7	I2C2_SCL	I2C3_SCL, PB_PWM
P0_GPIO8	I2C2_SDA	I2C3_SDA, PB_SYNC
P0_GPIO9	UART_DBG_Tx ⁽²⁾	I2C4_SCL
P0_GPIO10		I2C4_SDA, PB_PWM

- (1) Only one of the UART_Rx/UART_Tx or the LIN (TXD, RXD) functions is available for use at a time.
 (2) UART_DBG_Tx is only available for assignment to one pin at a time.

8.3.13.2 P1_GPOx

Figure 8-26 shows the GPIO I/O buffer for the P1_GPOx pins. These pins are fail-safe. A subset of the GPOs are ADC inputs (see Table 8-5).

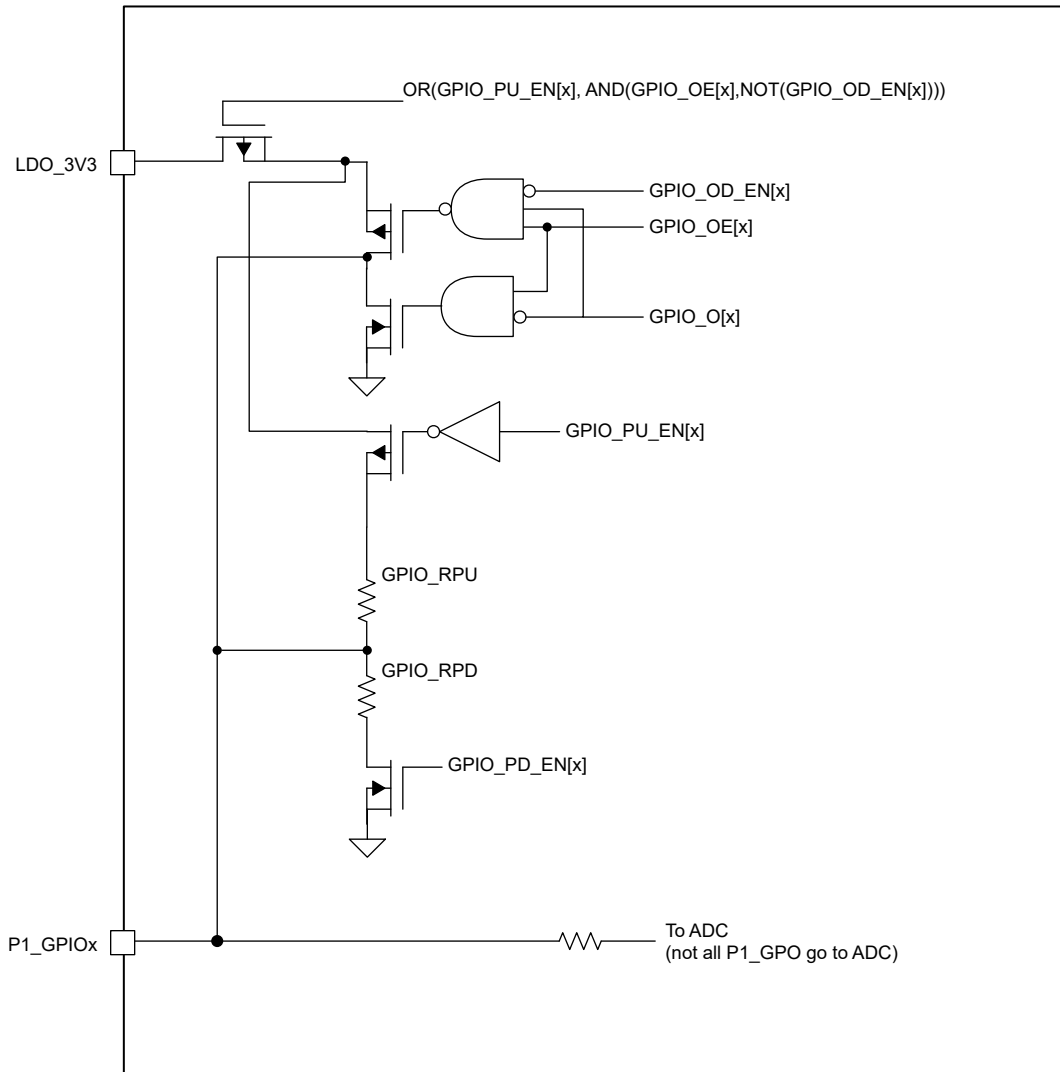

Figure 8-26. P1_GPOx Buffer

Table 8-5. P1_GPOx Functionality Table (ADCINx = ADC Input Channel x)

Pin Name	Special Functionality	Muxed Functionality	GPIO functionality
P1_GPO0	ADCIN2	PA_PPEXT	Push-Pull, weak pullup, weak pulldown
P1_GPO1	ADCIN3	PA_LQD	Open-drain output
P1_GPO2	ADCIN4	PB_LQD	Open-drain output
P1_GPO3	ADCIN5	PB_PPEXT	Push-Pull, weak pullup, weak pulldown
P1_GPO4		ENSD	Push-Pull, weak pullup, weak pulldown
P1_GPO5	PB_DM, ADCIN15		Open-drain output
P1_GPO6	PB_DP, ADCIN14		Open-drain output
P1_GPO7	PA_DP, ADCIN12, DBG_SDA		Open-drain output
P1_GPO8	PA_DM, ADCIN13, DBG_SCL		Open-drain output

8.3.14 ENSD Functionality

If the ENSD pin is low while the ENSD pin function is enabled then the device stays in the shutdown mode (see $I_{IN,SD}$). When ENSD is asserted low for longer than the deglitch time (T_{ENSD_DEG}), the TPS26742E-Q1 enters into the shutdown mode.

The ENSD pin is pulled up internally via the GPIO_RPU resistor. Therefore, do not apply any load stronger than 510k Ω . When the P1_GPO4 pin is configured as an output GPO instead of ENSD functionality, do not load the pin externally while the TPS26742E-Q1 is powering on. Instead apply an external pullup to LDO_3V3 if necessary to prevent ENSD from being low when the device powers on or resets.

8.3.15 Px_SYNC Output

Many DC/DC controllers have a SYNC input to synchronize switching. The TPS26742E-Q1 has Px_SYNC pins to drive this signal to the DC/DC on each port to prevent simultaneous switching of different DC/DC controllers in the system.

The internal HF_OSC clock is divided down to create a HF_SYNC clock used to drive a square wave to the selected P0_GPIO pin at f_{SYNC_NOM} . PA_SYNC and PB_SYNC are driven from the same clock, there are configurations to have 0°, 90°, 180°, or 270° phase delay between PA_SYNC and PB_SYNC.

The TPS26742E-Q1 also supports cycle-to-cycle dithering following a triangular frequency profile. The modulation frequency of this triangular wave is f_{MOD} , and max swing is f_{SYNC_SWING} .

The TPS26742E-Q1 also includes dual-random spread spectrum (DRSS) on the Px_SYNC signal by adding pseudorandom variation $f_{DITH}(t)$.

Combining all the configurations, the SYNC frequency f_{SYNC} (and therefore the time between rising edges on Px_SYNC) changes in time according to:

$$f_{SYNC}(t) = f_{SYNC_NOM} + f_{SYNC_SWING} \times \text{triangular}(2 \times \pi \times f_{MOD}(t) \times t) + f_{DITH}(t) \quad (1)$$

The P0_GPIOx used for the Px_SYNC functionality is configurable for open-drain or push-pull mode, and configurable to enable or disable the weak pullup or pulldown resistors.

Figure 8-27 shows three ways to use the Px_SYNC pin. First, if one of the DC/DC is configured to trigger on the rising edge of Px_SYNC and the other DC/DC is configured to trigger on the falling edge of Px_SYNC then only one Px_SYNC pin is necessary as shown in top left option. Another option is use use PA_SYNC and PB_SYNC to each connect to one of the two DC/DC. The third option is to use an NFET to invert the Px_SYNC signal so that the two DC/DC both trigger on the rising edge.

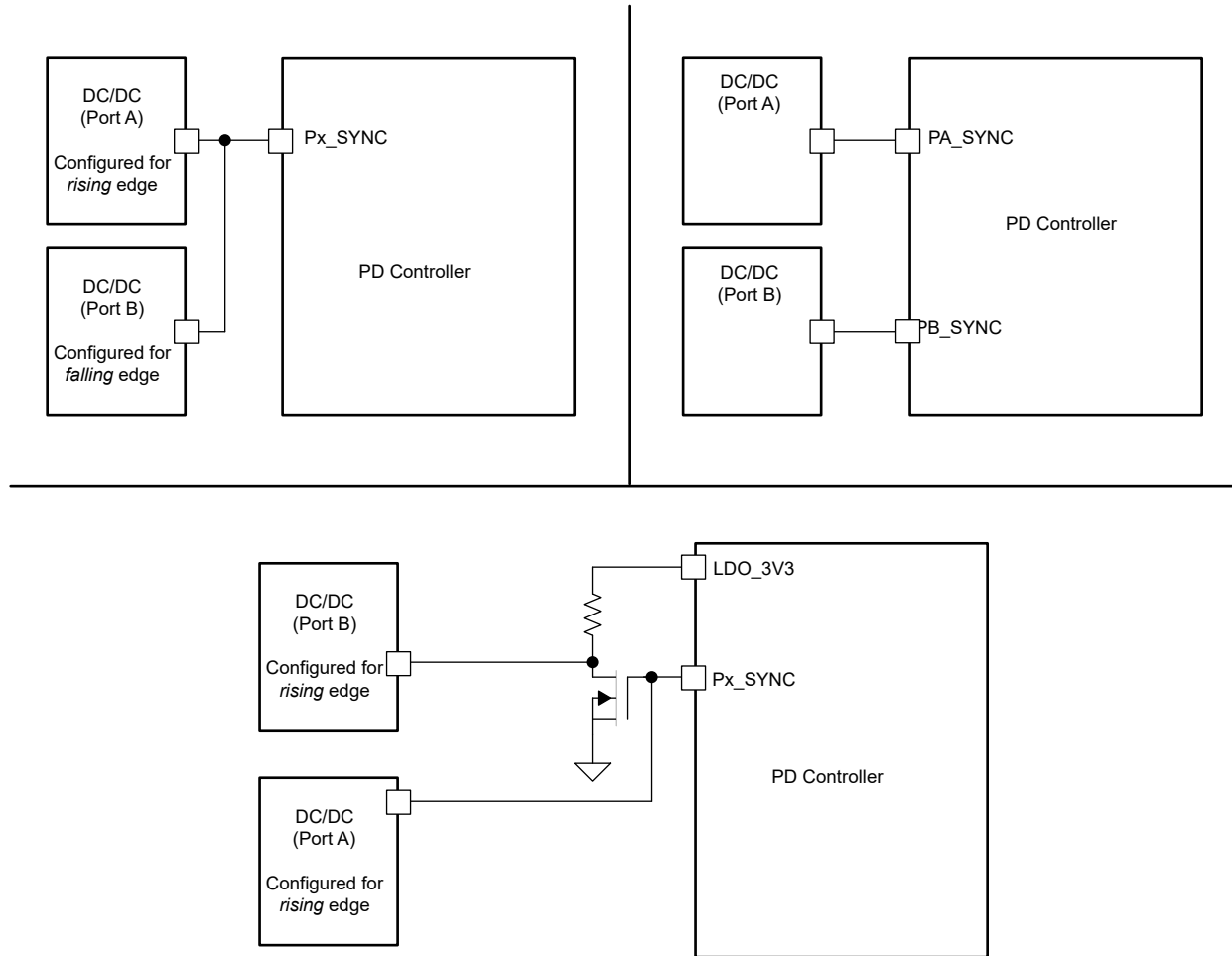

Figure 8-27. Configurations Using Px_SYNC

8.3.16 Pulse-Width Modulation (PWM) Output

The TPS26742E-Q1 has a PWM module available for various purposes such as controlling an LED or creating a dynamic voltage reference. The PWM module is configurable to have a duty cycle that is dynamic or fixed. The application firmware is also capable of dynamically setting the duty-cycle, for example to drive the VBUS voltage output from a DC/DC regulator.

When setting a fixed duty cycle the T_{PWM_ON} and T_{PWM_TOTAL} are controlled separately to set the duty-cycle (DC) $T_{PWM_ON} / T_{PWM_TOTAL}$. When configured to do so, the application firmware sets the DC as needed in different applications based on USB-PD or other kinds of events.

When using the dynamic duty-cycle option the duty-cycle varies periodically over T_{PWM_PERIOD} . There are configurable options for sinusoidal, triangular, or sawtooth variations.

The P0_GPIOx used for the Px_PWM functionality is configurable for open-drain or push-pull mode, with or without the weak pullup or pulldown resistors enabled.

8.3.17 I²C Interface

The TPS26742E-Q1 has multiple I²C ports. The following table lists the type and typical usage for each port. The target ports provide general status information about the TPS26742E-Q1, as well as the ability to control the behavior of the device. The controller port allows the TPS26742E-Q1 to control other target devices in the system.

Table 8-6. I²C Summary

I2C Bus	Type	Typical Usage
I2C1	Target	Connect to a host controller. This I2C provides access for updating flash memory. This I2C port has R/W access via the Host Interface.
I2C2	Controller	Connect to external DC/DC, USB Type-C mux, or other target devices.
I2C3	Target	For systems that require two I2C targets.
I2C4	Target	Available via DBG_SCL and DBG_SDA pins. When enabled, this I2C port has R/W access via the Host Interface and updating flash memory. If desired permanently disable this I2C port via configuration.

8.3.17.1 I²C Interface Hardware

The TPS26742E-Q1 features multiple I²C interfaces that each use an I²C I/O driver like the one shown below. This I/O consists of an open-drain output and an input comparator referenced to LDO_3V3 followed by de-glitching.

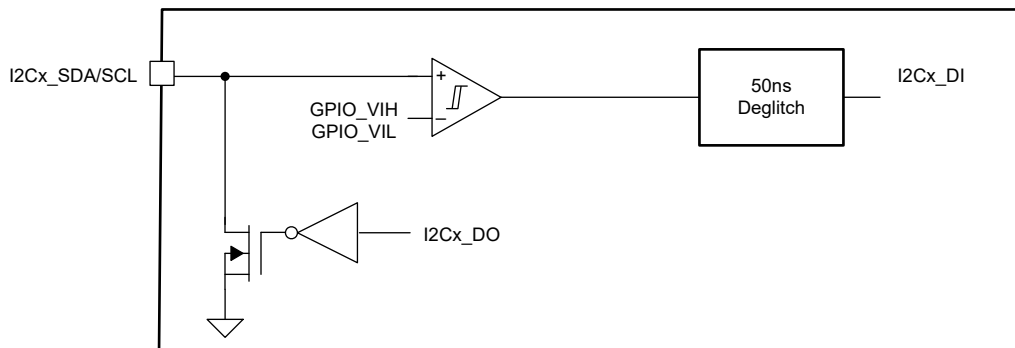

Figure 8-28. I²C Buffer

8.3.17.2 I²C Interface Description

The TPS26742E-Q1 supports Standard, Fast mode, and Fast-mode, plus I²C interfaces. The bidirectional I²C bus consists of the serial clock (SCL) and serial data (SDA) lines. Both lines are required to connect to a supply through a pull-up resistor.

Figure 8-29 shows the start and stop conditions of the transfer. Figure 8-30 shows the SDA and SCL signals for transferring a bit. Figure 8-31 shows a data transfer sequence with the ACK or NACK at the last clock pulse.

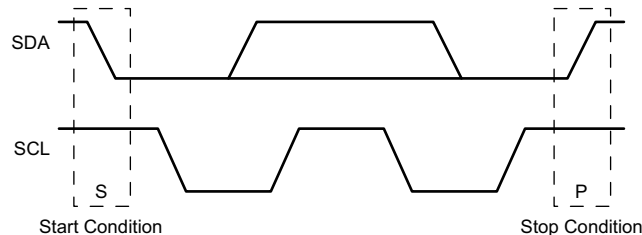

Figure 8-29. I²C Definition of Start and Stop Conditions

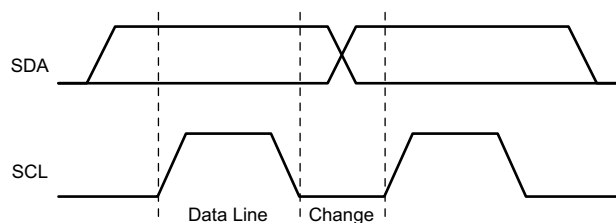

Figure 8-30. I²C Bit Transfer

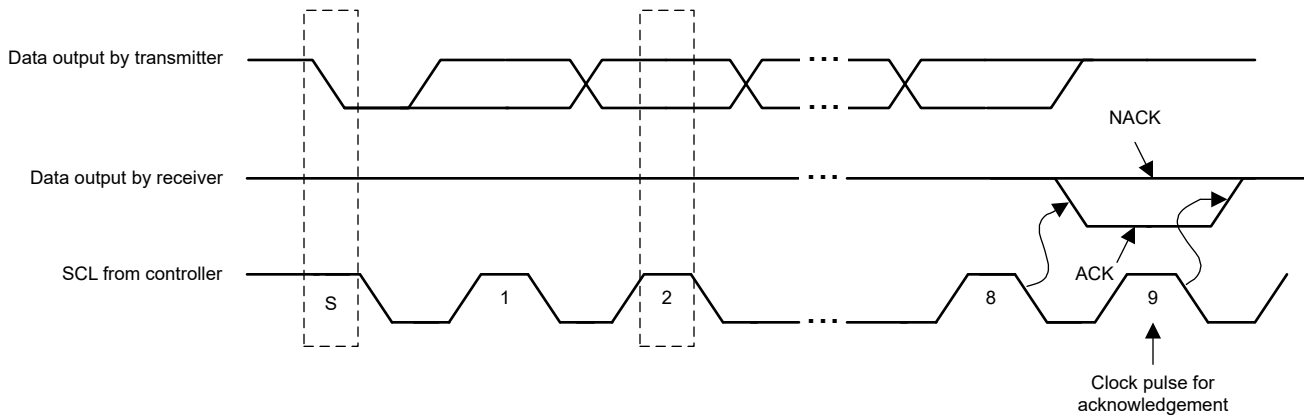

Figure 8-31. I²C Acknowledgment

8.3.17.3 I²C Clock Stretching

The TPS26742E-Q1 features clock stretching for the I²C protocol. In some scenarios, the TPS26742E-Q1 target I²C port holds the clock line (SCL) low after receiving (or sending) a byte, indicating that the target port is not yet ready to process more data. The controller communicating with the target is required to pause the transmission of the current bit and wait until the clock line goes high. When the target is clock stretching, the clock line remains low.

The controller is required to wait until the clock line transitions high plus an additional minimum time (4μs for standard 100kbps I²C) before pulling the clock low again.

Clock stretching is possible for any clock pulse but typically is the interval before or after the acknowledgment bit.

8.3.17.4 Unique Address Interface

The Unique Address Interface allows for complex interaction between an I²C controller and a single TPS26742E-Q1. The I²C target sub-address is used to receive or respond to Host Interface protocol commands. Figure 8-32 and Figure 8-33 show the write and read protocol for the I²C target interface, and a key is included in Figure 8-34 to explain the terminology used. The TPS26742E-Q1 Host interface utilizes a different unique address to identify each of the two USB Type-C ports controlled by the TPS26742E-Q1. The key to the protocol diagrams is in the SMBus Specification and is repeated here in part.

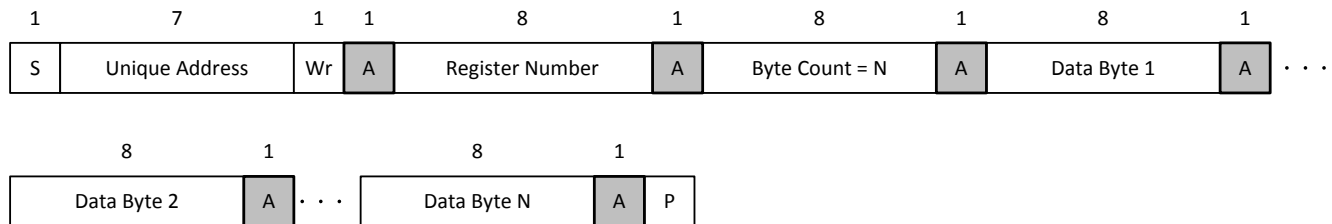

Figure 8-32. I²C Unique Address Write Register Protocol

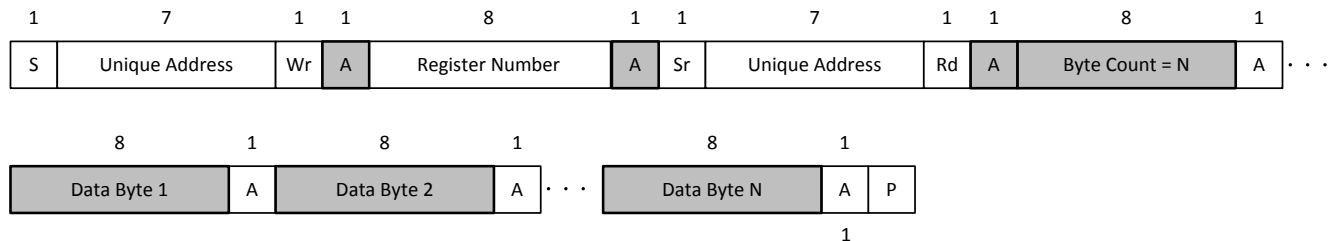

Figure 8-33. I²C Unique Address Read Register Protocol

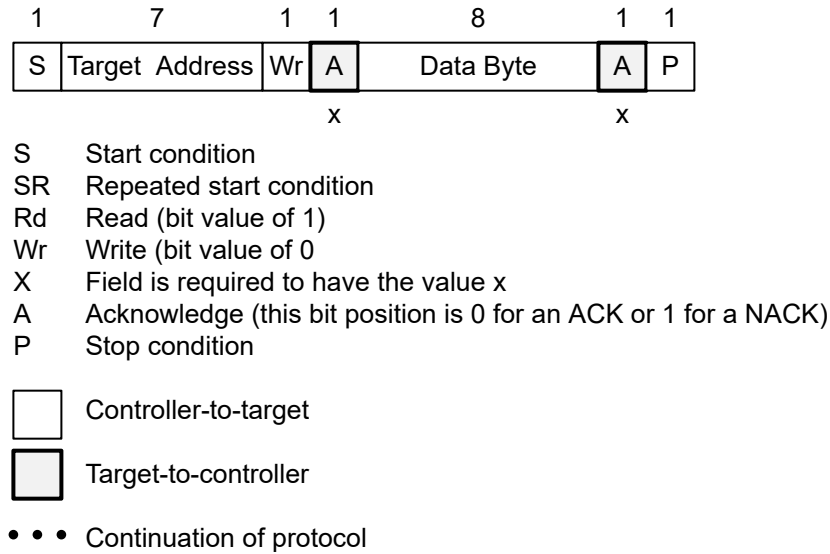

Figure 8-34. I²C Read/Write Protocol Key

8.3.17.5 I²C Address Setting

When multiple TPS26742E-Q1 devices are used in the same system, typically the I2C1_SDA and I2C1_SCL for each device are connected. Then an external I²C controller controls all devices via a single I2C bus. Therefore, the target addresses of the I²C target ports are set to the default value based on the CONFIG pin as shown in the following table. See Section 8.4.1 for details about configuring the CONFIG pin to select the default target address. These default addresses are the only addresses available for updating the flash memory.

Table 8-7. I2C Default Target Addresses (before loading configurations from flash)

I2C port	Port	Default Target Address (see I ² C address index from CONFIG decoding)			
		CONFIG = #1	CONFIG = #2	CONFIG = #3	CONFIG = #4
I2C1 / I2C4	A	0x20	0x21	0x22	0x23
	B	0x24	0x25	0x26	0x27

8.3.18 System Power Management (SPM) Across Ports

The TPS26742E-Q1 supports being connected to multiple other PD controllers to enable system power sharing across multiple ports. One of the TPS26742E-Q1 is configured as the Controller, and the other is configured as a Target. In the following diagram the I2C2 port from one device is connected to the I2C3 port from another device. Since the I2C2 is the controller port, it makes that device the Controller in the SPM context as well.

The SPM controller also handles power sharing for all ports within the SPM controller.

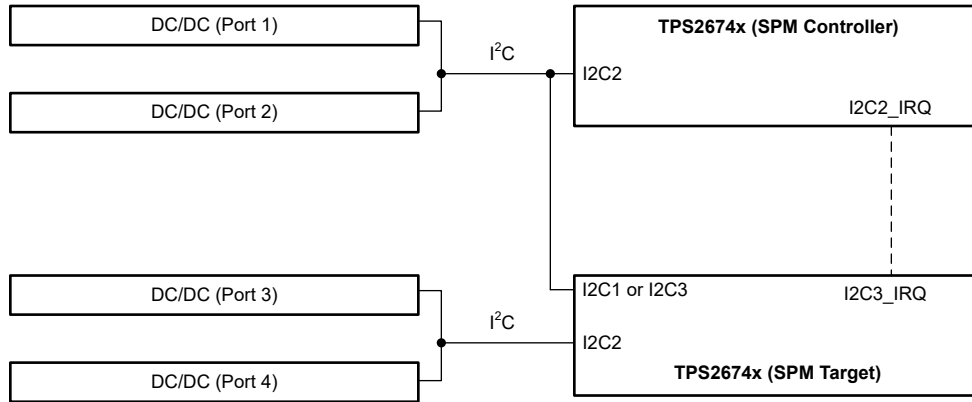

Figure 8-35. Illustration of Device-to-Device SPM

8.4 Device Functional Modes

8.4.1 Pin Strapping to Configure Default Behavior (CONFIG)

The CONFIG pin is used to configure the default I2C address index as summarized in the following table.

The UART_Tx pin function is allowed on the CONFIG pin. The I2C1 address decoding is not affected. When transmitting, the UART_Tx pin function overdrives the external resistance.

Table 8-8. CONFIG Decoding

R_{UP}	R_{DOWN}	CONFIG decoding	I ² C address index
∞	$499k\Omega \pm 5\%$	00	#1
$499k\Omega \pm 5\%$	∞	01	#2
$< 5k\Omega$	∞	10	#3
∞	$< 5k\Omega$	11	#4

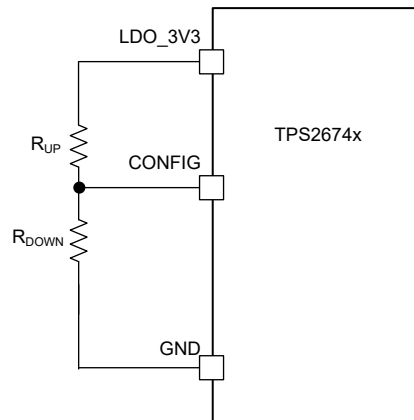

Figure 8-36. I2C_ADDR Pin Configuration

8.4.2 Power States

The TPS26742E-Q1 operates in one of four different power states: Active, Idle, Sleep or Shutdown. The functionality available in each state is summarized in [Table 8-9](#). The device automatically transitions between the power states based on the circuits that are active and required, see [Figure 8-37](#). In the Sleep State the TPS26742E-Q1 detects a Type-C connection or other activity that requires moving to the Active state (such as liquid detection actions). Transitioning between the Active mode to the Idle mode requires a period of time (T) without any of the following activity:

- Incoming USB PD message
- Change in CC status
- GPIO input event
- I²C transactions
- Voltage alert
- Fault alert

During boot mode, the TPS26742E-Q1 remains in the Active State.

The device enters sleep mode when both ports meet the sleep state entry conditions (CC detached and no activity).

The Shutdown mode is entered when the ENSD pin is configured as active (which is the default at power-on) and the ENSD pin is pulled low. Entering the Shutdown mode overrides any other power state condition. It is important to note that the device is non-functional while in the Shutdown mode. The ENSD pin is configured by default at power-on so the device is non-functional if the ENSD pin is pulled low.

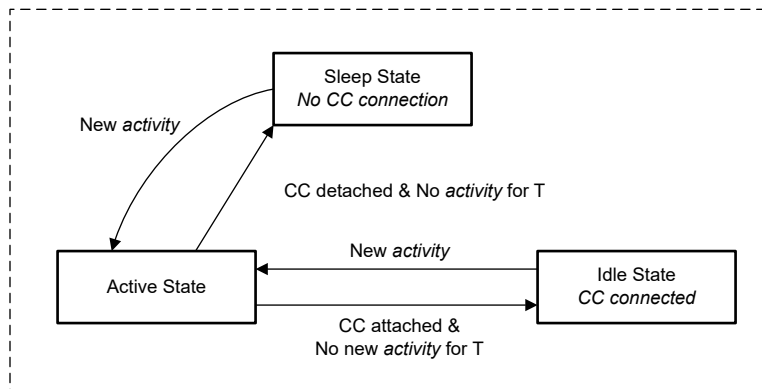

Figure 8-37. Flow Diagram For Power States

Table 8-9. Power Consumption States

	Active Mode $I_{IN,Act}$	Idle Mode $I_{IN,Idle}$	Sleep Mode $I_{IN,Sleep}$	Shutdown Mode
PA_VCONN	ON	OFF	OFF	OFF
PB_VCONN	ON	OFF	OFF	OFF
PortA Cable Detection	$I_{Rp3.0}$ enabled	$I_{Rp3.0}$ enabled	I_{RpDef} enabled	Disabled
PortB Cable Detection	$I_{Rp3.0}$ enabled	$I_{Rp3.0}$ enabled	I_{RpDef} enabled	Disabled
external PA_CCx termination	5.1k Ω (Rd)	5.1k Ω (Rd)	5.1k Ω (Rd)	don't care
external PA_CCy termination	open	open	open	don't care
external PB_CCx termination	5.1k Ω (Rd)	5.1k Ω (Rd)	5.1k Ω (Rd)	don't care
external PB_CCy termination	open	open	open	don't care
Liquid detection	ON, Px_LQD held low	OFF	OFF	OFF
USB-PD PHY	Transmitting on both ports	Squelch Rx enabled ready to wake on both ports	OFF	OFF
I2C traffic	I2C1, I2C2, I2C3, and I2C4 all active	No activity, monitoring for wake only	No activity, monitoring for wake only	don't care
CPU	Active, reading and writing to SRAM	Sleep	Sleep	Disabled
Flash	Actively executing from flash.	Inactive	Inactive	Inactive

9 Application and Implementation

Note

Information in the following applications sections is not part of the TI component specification, and TI does not warrant its accuracy or completeness. TI's customers are responsible for determining suitability of components for their purposes, as well as validating and testing their design implementation to confirm system functionality.

9.1 Application Information

The TPS26742E-Q1 firmware implements a host interface over I²C to allow for the configuration and control of all device options. Initial device configuration is stored in flash and is loaded during boot. The TPS26742E-Q1 configuration and host interface allow the device to be customized for each specific application.

9.2 Typical Application

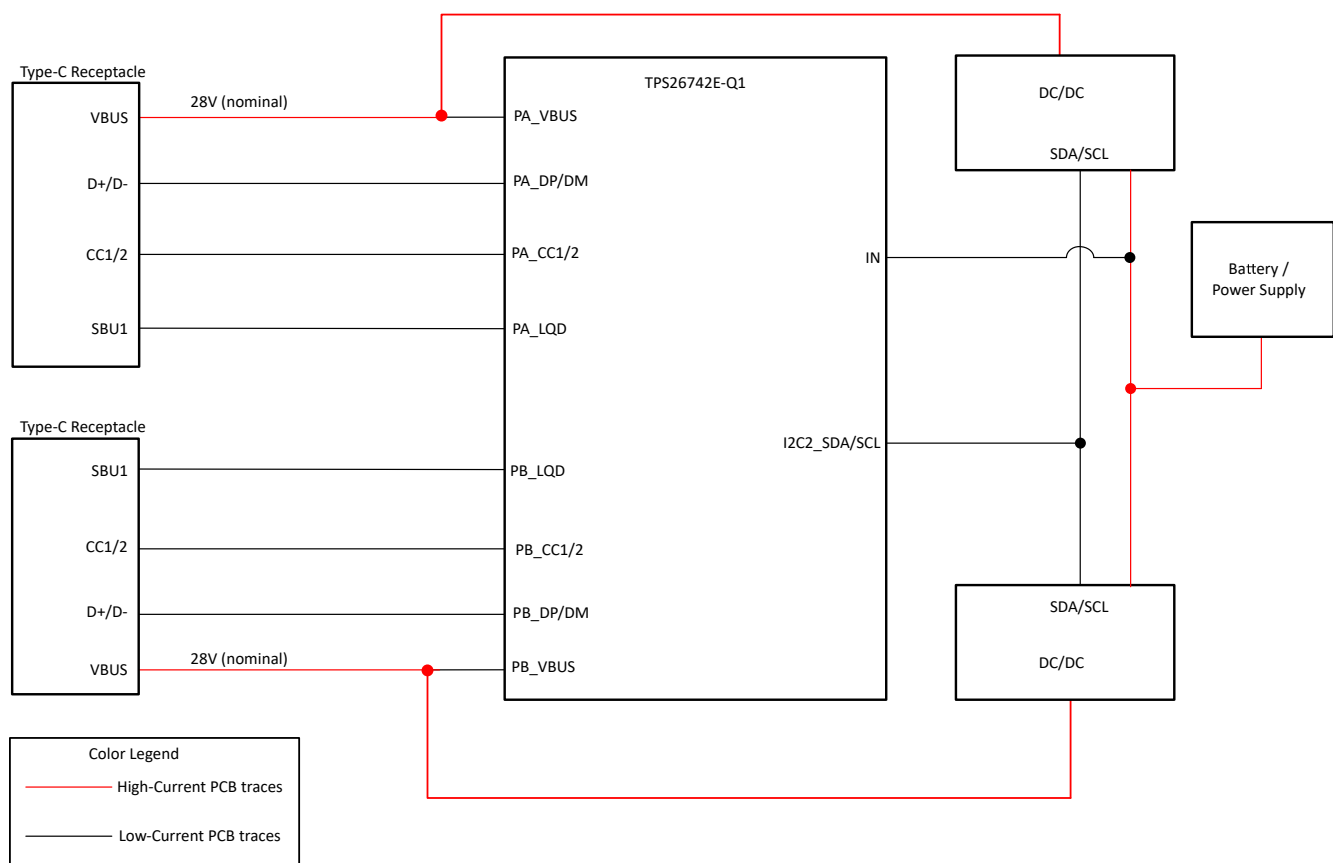

9.2.1 Design Requirements

9.2.1.1 CC Pin Recommendations

The TPS26742E-Q1 has 2 USB Type C Ports. For each of these ports, the CC pins - PA_CC1, PA_CC2, PB_CC1, and PB_CC2 are bypassed with C_{PX_CCy}

9.2.1.2 TI Firmware Update (TFU)

Update the TPS26742E-Q1 firmware through two possible I2C port connections: make the I2C1 target interface or the DBG I2C target interface available when I/O assignments are made during device configuration. Firmware configuration allows permanently disabling the FW update feature.

Here are three methods to meet this requirement:

1. Assign P0_GPIO5 to I2C1_SCL and P0_GPIO5 to I2C1_SDA.
 - a. Connect the two GPIO pins to LDO_3V3 or an MCU 3.3V power supply through appropriately sized pull up resistors.
2. Assign P1_GPO7 to DBG_SCL and P1_GPO8 to DBG_SDA.
 - a. Connect the two GPIO pins to LDO_3V3 or an MCU 3.3V power supply through appropriately sized pull up resistors.
3. Assign P1_GPO7 to DP and P1_GPO8 to DM and connect these pins to appropriate pins on the type C connector.
 - a. Connect these pins to the internal DBG_I2C pins when the type C connection type is a Debug Accessory.
 - b. The Debug Accessory connection provides the pull-up resistor connection to a 3.3V power supply.

9.2.2 Detailed Design Procedure

TFU Update Method

For this design, the TFU update method selected is the USB Type-C debug accessory connection on the Port A DP and DM pins. These pins are converted to an I2C target interface when a debug accessory is connected to the port A type C port. This I2C target supports firmware update.

I2C Controller Connections

The I2C controller port (I2C2_SCL and I2C2_SDA) are used to control the I2C target ports on the port A DC2DC, port B DC2DC, and Display port System mux.

Power Supply Connections

Connect the Power Supplies as specified in [Section 9.4](#).

Type C Port Connections

The PA_CC1, PA_CC2, PB_CC1, and PB_CC2 pins need to be bypassed as specified in [Section 9.2.1.1](#).

In this example, 28V is the highest nominal VBUS, so no resistive divider is required. When required connect a resistor divider that divides VBUS in half to limit the voltage on the Px_VBUS pin. Use resistors with a value of 10kΩ.

GPIO Configuration

Configure the GPIO and GPO pins of the TPS26742E-Q1 as required to meet system needs. The application configuration GUI: [TPS267xx-Q1-GUI](#) supports various configuration options.

Table 9-1. P0_GPIO Configuration

TPS26742E-Q1 ports	Port Configuration Setting	Passives
P0_GPIO0		
P0_GPIO1		
P0_GPIO2		
P0_GPIO3		
P0_GPIO4		
P0_GPIO5		

Table 9-1. P0_GPIO Configuration (continued)

TPS26742E-Q1 ports	Port Configuration Setting	Passives
P0_GPIO6		
P0_GPIO7	I2C2_SCL	2.2kΩ pull-up to LDO_3V3
P0_GPIO8	I2C2_SDA	2.2kΩ pull-up to LDO_3V3
P0_GPIO9	CONFIG	600kΩ pull-down to GND
P0_GPIO10		

Table 9-2. P1_GPO Configuration

TPS26742E-Q1 ports	Port Configuration Setting	Passives
P1_GPO0		
P1_GPO1	PA_LQD	
P1_GPO2	PB_LQD	
P1_GPO3		
P1_GPO4		
P1_GPO5	PB_DM	
P1_GPO6	PB_DP	
P1_GPO7	PA_DP	
P1_GPO8	PA_DM	

9.2.3 Application Curves

The figure below shows the VBUS voltage, PA_CC1 (PD Communication) and I2C2 communication to the DC2DC Converter. The following table shows a log of the PD communication for the same test:

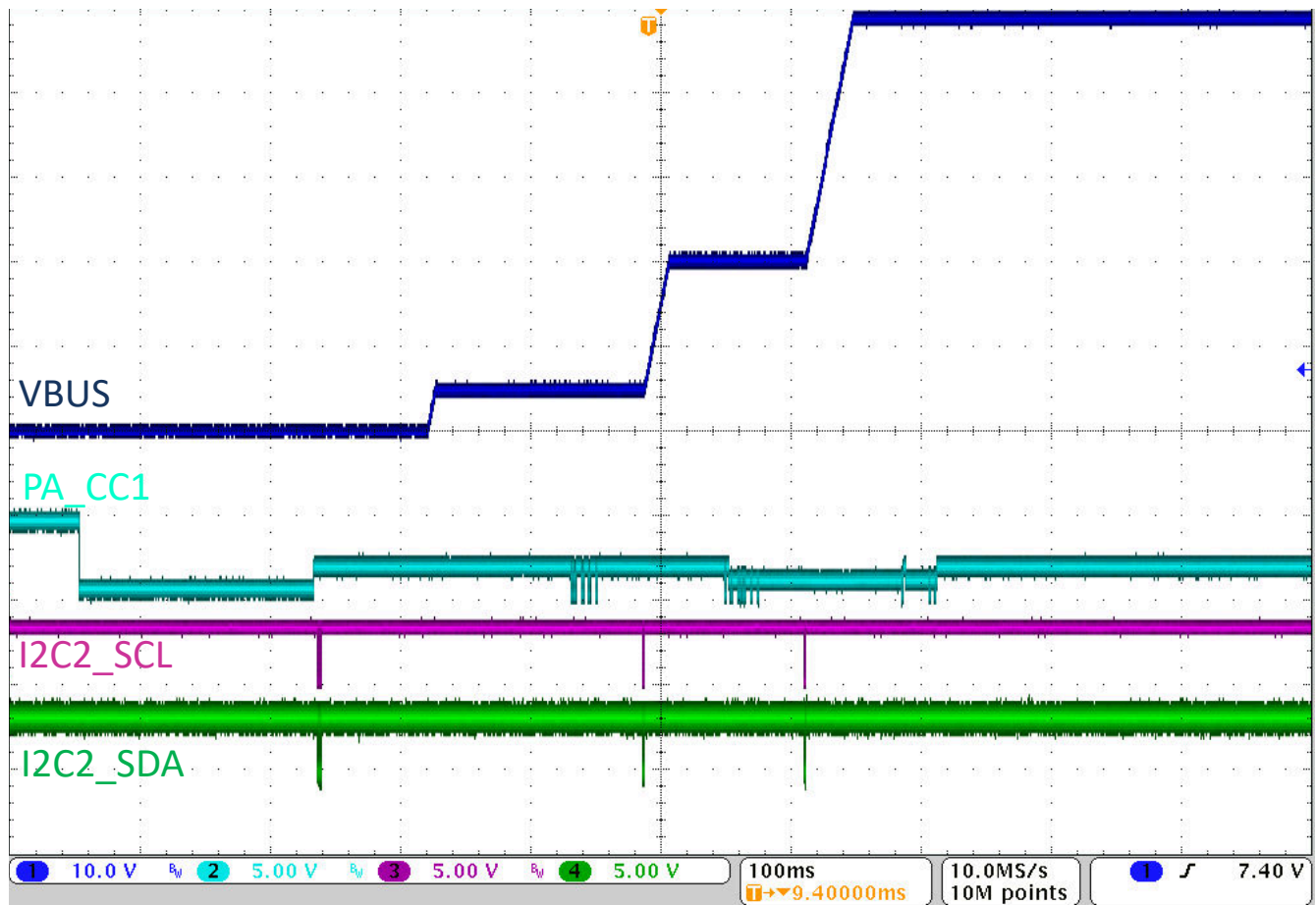

Figure 9-1. 48V EPR Transition

Table 9-3. PD Log for EPR 48V/5A Connection

#	Message Type	SOP*	DataRole	PowerRole	MsgID	Sender	TimeStamp (ms)
0	CONNECT CABLE RA OR SINK NO VBUS (CC1-Pin = NC, CC2-Pin = STD)						0
1	CONNECT SINK NO VBUS (CC1-Pin = NC, CC2-Pin = 3p0A)						177.0
2	CONNECT CC2 (CC1-Pin = NC, CC2-Pin = 3p0A)						267.0
3	Vendor_Defined (Disc ID REQ)	SOP'	N/A	N/A	0	Port	366.1
4	GoodCRC	SOP'	N/A	N/A	0	Plug	367.0
5	Vendor_Defined (Disc ID ACK, PassiveCable)	SOP'	N/A	N/A	0	Plug	369.0
6	GoodCRC	SOP'	N/A	N/A	0	Port	370.0
7	Source_Capabilities (Max: 100W, Fixed 5V-3A, Fixed 9V-3A, Fixed 15V-3A, Fixed 20V-5A, SPR AVS MaxI (9V/15V)=3A MaxI (15V/20V)=5A, PPS PDP=48W;PL:0;5V-16V-3A, PPS PDP=100W;PL:1;5V-21V-5A)	SOP	DFP	SOURCE	0	Port	374.1
8	GoodCRC	SOP	UFP	SINK	0	Port	376.0
9	Request (RDO: Pos=5, Pow=100W,outV=20.00V,loc=5.00A; Src APDO: SPR AVS MaxI (9V/15V)=3A MaxI (15V/20V)=5A)	SOP	UFP	SINK	0	Port	380.0
10	GoodCRC	SOP	DFP	SOURCE	0	Port	381.0
11	Accept	SOP	DFP	SOURCE	1	Port	385.0
12	GoodCRC	SOP	UFP	SINK	1	Port	386.0
13	PS_RDY	SOP	DFP	SOURCE	2	Port	483.0
14	GoodCRC	SOP	UFP	SINK	2	Port	484.0
15	EPR_Mode (Action=Enter)	SOP	UFP	SINK	1	Port	488.0
16	GoodCRC	SOP	DFP	SOURCE	1	Port	488.1
17	CONNECT CC CHANGE (CC1-Pin = NC, CC2-Pin = 1p5A)						493.0
18	EPR_Mode (Action=Enter_Acknowledged)	SOP	DFP	SOURCE	3	Port	493.0
19	GoodCRC	SOP	UFP	SINK	3	Port	393.0
20	EPR_Mode (Action=Enter_Succeeded)	SOP	DFP	SOURCE	4	Port	495.0
21	GoodCRC	SOP	UFP	SINK	4	Port	495.1
22	EPR_Source_Capabilities (Max: 240W, Fixed 5V-3A, Fixed 9V-3A, Fixed 15V-3A, Fixed 20V-5A, SPR AVS MaxI (9V/15V)=3A MaxI (15V/20V)=5A, PPS PDP=48W;PL:0;5V-16V-3A, PPS PDP=100W;PL:1;5V-21V-5A, Fixed 28V-5A, Fixed 36V-5A, Fixed 48V-5A, EPR AVS PDP:240-48V-15V)	SOP	DFP	SOURCE	5	Port	497.0
23	GoodCRC	SOP	UFP	SINK	5	Port	499.0
24	EPR_Request (RDO: Pos=11, Pow=240W,outV=48.00V,loc=5.00A; Src APDO: EPR AVS PDP=240-15V-48V)	SOP	UFP	SINK	2	Port	503.0
25	GoodCRC	SOP	DFP	SOURCE	2	Port	504.0
26	Accept	SOP	DFP	SOURCE	6	Port	508.0
27	GoodCRC	SOP	UFP	SINK	6	Port	509.0
28	PS_RDY	SOP	DFP	SOURCE	7	Port	618.0
29	GoodCRC	SOP	UFP	SINK	7	Port	638.1
30	Vendor_Defined (Disc ID REQ)	SOP	DFP	SOURCE	0	Port	638.1
31	GoodCRC	SOP	UFP	SINK	0	Port	639.0
32	Not_Supported	SOP	UFP	SINK	3	Port	643.0
33	GoodCRC	SOP	DFP	SOURCE	3	Port	644.0
34	CONNECT CC CHANGE (CC1-Pin = NC, CC2-Pin = 3p0A)						650.1

Table 9-3. PD Log for EPR 48V/5A Connection (continued)

#	Message Type	SOP*	DataRole	PowerRole	MsgID	Sender	TimeStamp (ms)
35	Extended_Control (EPR_KeepAlive)	SOP	UFP	SINK	4	Port	1034.1
36	GoodCRC	SOP	DFP	SOURCE	4	Port	1035.0
37	Extended_Control (EPR_KeepAlive_Ack)	SOP	DFP	SOURCE	1	Port	1040.0

9.3 System Examples

The TPS26742E-Q1 supports USB-PD charging in the extended power range (EPR) for two USB-C ports.

When a system has more than two USB-C ports, connecting multiple TPS26742E-Q1 together via I2C allows one of them to act as the system power management (SPM) controller, while the others act as targets.

The TPS26742E-Q1 is capable to provide access to an external MCU to allow it to monitor status and control certain behaviors and configurations through the I2C1 port.

Connecting the Px_LQD pins of the TPS26742E-Q1 to one of SBU1, SBU2, D+ or D- on the USB-C receptacle it to perform liquid detection and implement corrosion mitigation to protect the USB-C connector.

9.3.1 Dual-Port EPR Charger

[Figure 9-2](#) illustrates connecting two TPS26742E-Q1 together to create a 4-port system. The TPS26742E-Q1 uses I2C2 to control external DC/DCs to provide the necessary voltage and/or current on each port individually. The TPS26742E-Q1 has an internal LDO connected to the same battery / power supply as the DC/DC. This internal LDO also provides the current needed for VCONN to read an eMarker.

In this example, the top TPS26742E-Q1 is the smart-power-management (SPM) controller and uses the I2C2 port to control the SPM target. The SPM target uses the I2C1 port to communicate with the SPM controller.

In this example, the bottom TPS26742E-Q1 supports a nominal 48V VBUS. Connect a resistor divider that divides VBUS in half to limit the voltage on the Px_VBUS pins. Use resistors with a value of 10kΩ.

External OVP options are shown to protect Px_CCy, Px_DP/DM, and Px_LQD pins from shorting to VBUS in the connector.

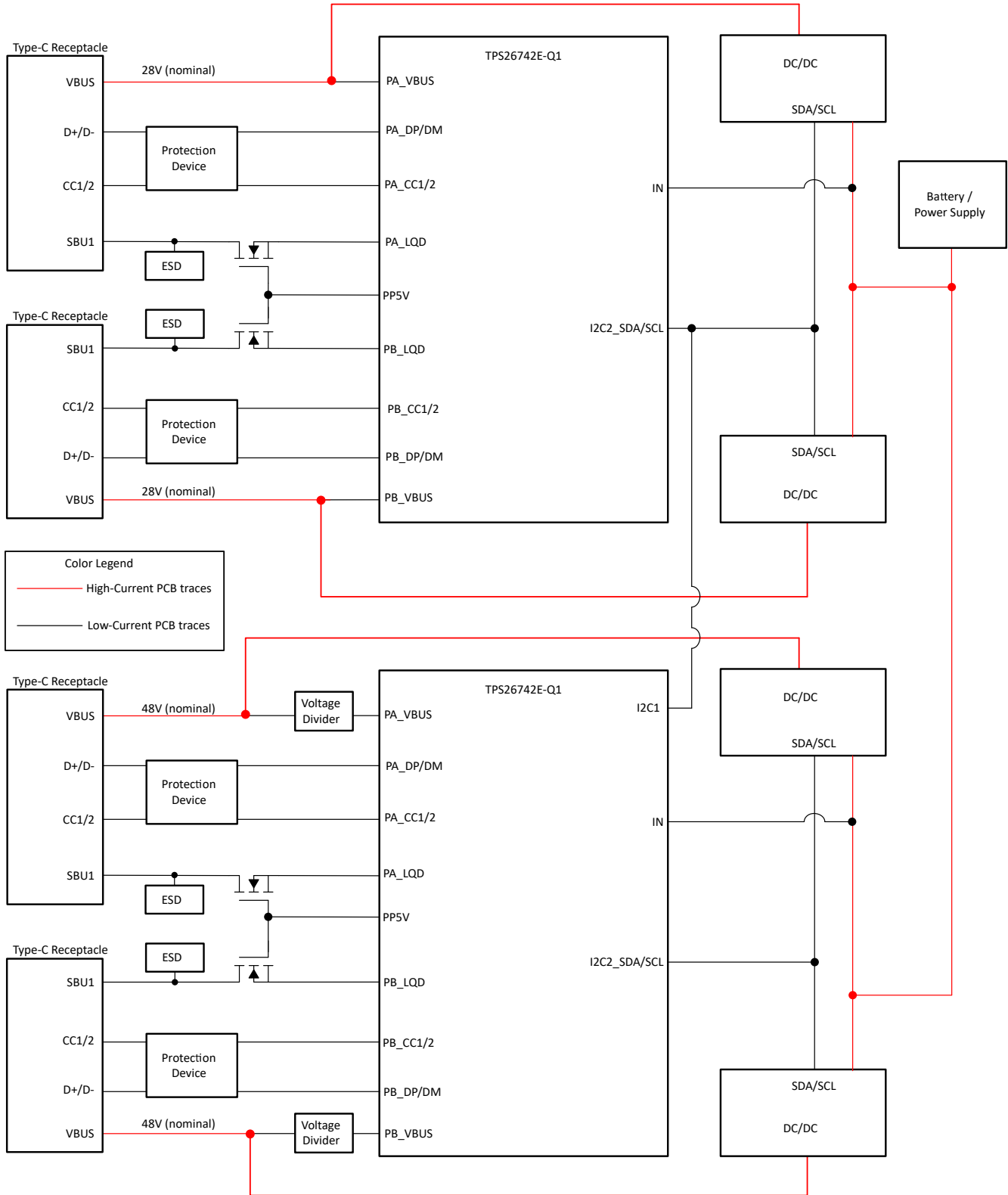

Figure 9-2. Dual-Port EPR Charger

9.4 Power Supply Recommendations

9.4.1 Input Power Supply

The IN pin is the primary power input for the device. An internal 5V LDO takes IN as an input to create 5V on the PP5V pin. When an external 5V is applied to the PP5V pin, short the IN pin to the PP5V pin to allow $V_{IN} \geq V_{PP5V}$. Connect the recommended capacitance C_{IN} from the IN pin to the GND pin. Place C_{IN} as close to the pin as possible.

9.4.2 5V Power Supply

Some internal circuitry is powered from 5V. The 5V LDO steps the voltage down from IN to 5V. The 5V LDO provides power to the internal 3.3V LDO, as well as internal analog circuits including Px_VCONN in some cases. Connect the recommended capacitance C_{PP5V} from the PP5V pin to the GND pin, and as close to the PP5V pin as possible.

9.4.3 3.3V Power Supply

Some internal circuitry is powered from 3.3V. The 3.3V LDO steps the voltage down from PP5V to 3.3V. The 3.3V LDO provides power to the internal 1.35V LDO and other internal circuits. Connect the recommended capacitance C_{LDO_3V3} from the LDO_3V3 pin to the GND pin, and as close to the LDO_3V3 pin as possible.

9.4.4 1.35V Power Supply

Some internal circuitry is powered from 1.35V. The 1.35V LDO steps the voltage down from LDO_3V3 to 1.35V. The 1.35V LDO provides power to all internal low-voltage digital circuits which includes the digital core, and memory. Connect the recommended capacitance C_{LDO_1V35} from the LDO_1V35 pin to the GND pin, and as close to the LDO_1V35 pin as possible.

9.5 Layout

9.5.1 Layout Guidelines

Proper component placement and routing are essential for maintaining signal integrity and optimizing power delivery performance. The combination of high speed differential data and high current power paths requires careful consideration of trace geometry, ground referencing, and copper thickness. Follow these best practices:

- Place all decoupling capacitors as close as possible to the associated pins.
- For 5A operation, maintain the thickness of the DCDC power traces on 1oz copper layers to be at least 130 mil wide.
- Route I2C lines away from USB data traces to prevent crosstalk.
- Maintain a continuous ground plane beneath all high speed differential pairs to offer good impedance control and provide EMI shielding.
- Avoid stubs on high speed lines to minimize the reflections. If the line is to be routed to multiple locations, use a separate line driver for each line.
- Consult with board manufacturing to verify manufacturing capabilities.

For additional layout guidelines for 4-switch buck-boost converters, see the [Layout Optimization of 4-Switch Buck-Boost Converters](#) Application Note. For additional high-speed layout guidelines, see the [High-Speed Layout Guidelines for Signal Conditioners and USB Hubs](#) Application Report.

Recommended Via Size

Recommended Via Size Proper via stitching is recommended to carrying current for the VBUS power paths and grounding. The recommended minimum via size is shown below, but larger vias are an option for low density PCB designs. A single via is capable of carrying 1A, verify the tolerance with the board manufacturing. Vias are recommended to be tented when located close to the PD controller.

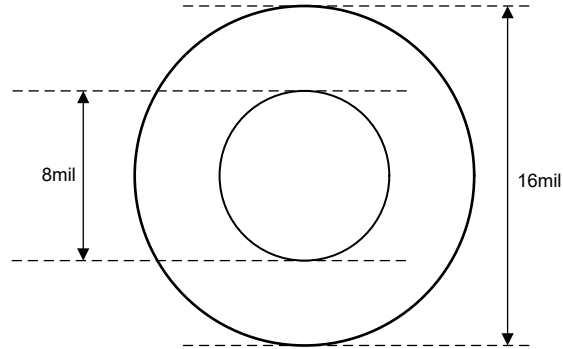

Minimum Trace Widths

Below are the minimum trace widths for analog and digital pins. The trace width limitations are also defined by the board manufacturing process used. Consult with manufacturing for determining the minimum trace widths and tolerance

Table 9-4. Minimum Trace Width

Route	Minimum Width (mils)
VIN, PP5V	10 (External Layers), 20 (Internal Layers)
PA_CC1, PA_CC2, PB_CC1, PB_CC2	10
LDO_1V35, LDO_3V3, PA_VBUS, PB_VBUS	10
P0_GPIOX/*, P1_GPOX/*	4 (Or Manufacturing Limit)
Component GND	16

9.5.2 Layout Example

Table 9-5. Composite Views



Top Composite	Bottom Composite
 <p>The top composite view shows a central component U1 with various resistors (R1-R5) and capacitors (C1-C10) connected to it. The layout includes a dense array of traces and pads.</p>	 <p>The bottom composite view shows the reverse side of the PCB, featuring a grid of pads and traces that correspond to the components on the top side.</p>

Table 9-6. Copper and Routing Layers

Top Layer 1	GND Layer 2	GND Layer 3	Bottom Layer 4
			

10 Device and Documentation Support

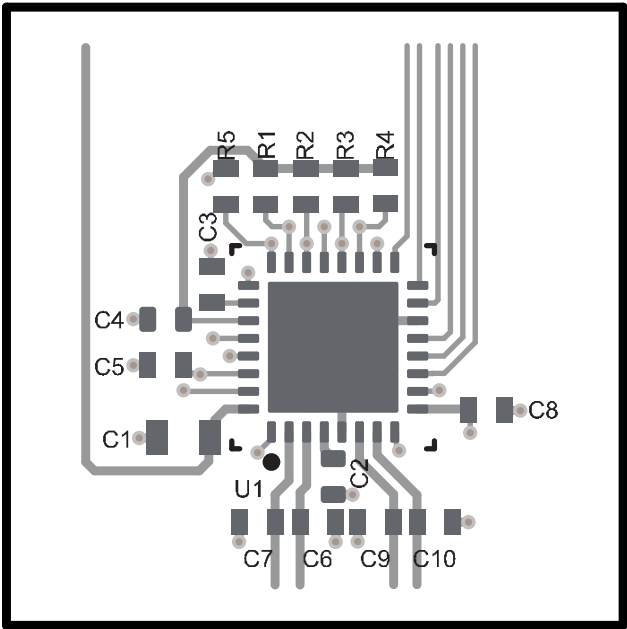
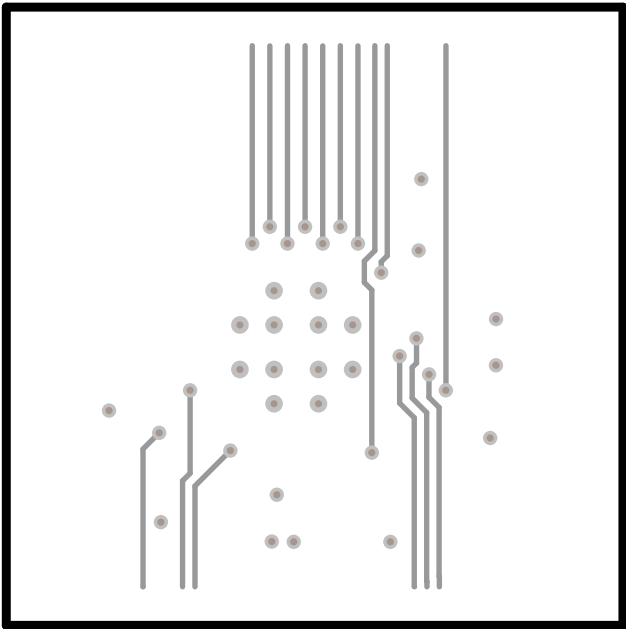
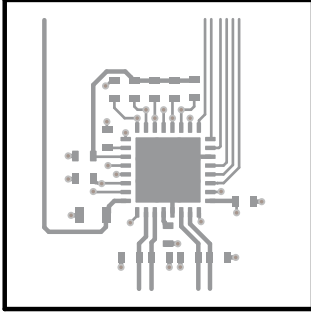
TI offers an extensive line of development tools. Tools and software to evaluate the performance of the device, generate code, and develop applications are listed below.

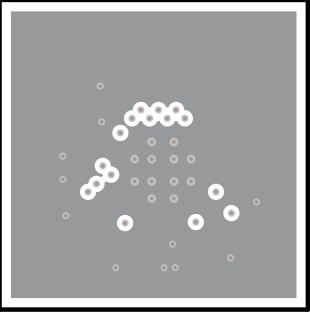
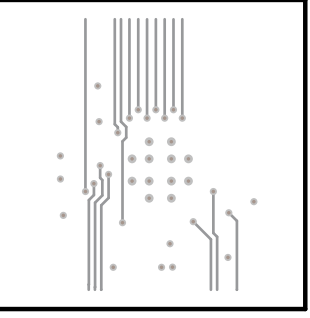
10.1 Documentation Support

10.1.1 Related Documentation

- [USB-PD Specifications](#)
- [USB Power Delivery Specification](#)

10.2 Receiving Notification of Documentation Updates

To receive notification of documentation updates, navigate to the device product folder on ti.com. Click on *Notifications* to register and receive a weekly digest of any product information that has changed. For change details, review the revision history included in any revised document.

10.3 Support Resources

[TI E2E™ support forums](#) are an engineer's go-to source for fast, verified answers and design help — straight from the experts. Search existing answers or ask your own question to get the quick design help you need.

Linked content is provided "AS IS" by the respective contributors. They do not constitute TI specifications and do not necessarily reflect TI's views; see TI's [Terms of Use](#).

10.4 Trademarks

TI E2E™ is a trademark of Texas Instruments.

USB Type-C® is a registered trademark of USB Implementers Forum.

All trademarks are the property of their respective owners.

10.5 Electrostatic Discharge Caution



This integrated circuit can be damaged by ESD. Texas Instruments recommends that all integrated circuits be handled with appropriate precautions. Failure to observe proper handling and installation procedures can cause damage.

ESD damage can range from subtle performance degradation to complete device failure. Precision integrated circuits may be more susceptible to damage because very small parametric changes could cause the device not to meet its published specifications.

10.6 Glossary

[TI Glossary](#) This glossary lists and explains terms, acronyms, and definitions.

11 Revision History

NOTE: Page numbers for previous revisions may differ from page numbers in the current version.

DATE	REVISION	NOTES
May 2026	*	Initial Release

12 Mechanical, Packaging, and Orderable Information

The following pages include mechanical, packaging, and orderable information. This information is the most current data available for the designated devices. This data is subject to change without notice and revision of this document. For browser-based versions of this data sheet, refer to the left-hand navigation.

PACKAGING INFORMATION

Orderable part number	Status (1)	Material type (2)	Package Pins	Package qty Carrier	RoHS (3)	Lead finish/ Ball material (4)	MSL rating/ Peak reflow (5)	Op temp (°C)	Part marking (6)
TPS26742EAAQRHBRQ1	Active	Production	VQFN (RHB) 32	5000 LARGE T&R	Yes	NIPDAU	Level-2-260C-1 YEAR	-40 to 125	T26742E AA

(1) **Status:** For more details on status, see our [product life cycle](#).

(2) **Material type:** When designated, preproduction parts are prototypes/experimental devices, and are not yet approved or released for full production. Testing and final process, including without limitation quality assurance, reliability performance testing, and/or process qualification, may not yet be complete, and this item is subject to further changes or possible discontinuation. If available for ordering, purchases will be subject to an additional waiver at checkout, and are intended for early internal evaluation purposes only. These items are sold without warranties of any kind.

(3) **RoHS values:** Yes, No, RoHS Exempt. See the [TI RoHS Statement](#) for additional information and value definition.

(4) **Lead finish/Ball material:** Parts may have multiple material finish options. Finish options are separated by a vertical ruled line. Lead finish/Ball material values may wrap to two lines if the finish value exceeds the maximum column width.

(5) **MSL rating/Peak reflow:** The moisture sensitivity level ratings and peak solder (reflow) temperatures. In the event that a part has multiple moisture sensitivity ratings, only the lowest level per JEDEC standards is shown. Refer to the shipping label for the actual reflow temperature that will be used to mount the part to the printed circuit board.

(6) **Part marking:** There may be an additional marking, which relates to the logo, the lot trace code information, or the environmental category of the part.

Multiple part markings will be inside parentheses. Only one part marking contained in parentheses and separated by a "-" will appear on a part. If a line is indented then it is a continuation of the previous line and the two combined represent the entire part marking for that device.

Important Information and Disclaimer: The information provided on this page represents TI's knowledge and belief as of the date that it is provided. TI bases its knowledge and belief on information provided by third parties, and makes no representation or warranty as to the accuracy of such information. Efforts are underway to better integrate information from third parties. TI has taken and continues to take reasonable steps to provide representative and accurate information but may not have conducted destructive testing or chemical analysis on incoming materials and chemicals. TI and TI suppliers consider certain information to be proprietary, and thus CAS numbers and other limited information may not be available for release.

In no event shall TI's liability arising out of such information exceed the total purchase price of the TI part(s) at issue in this document sold by TI to Customer on an annual basis.

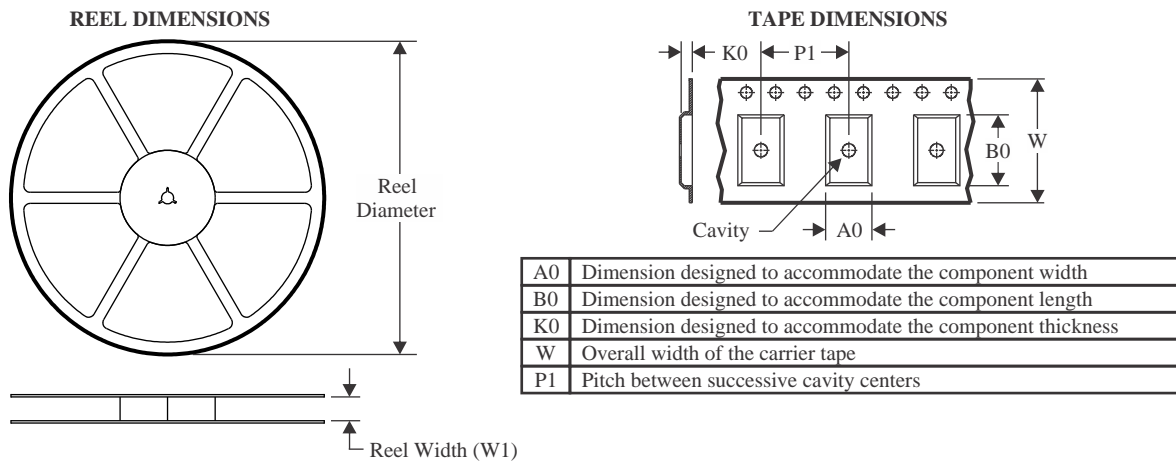
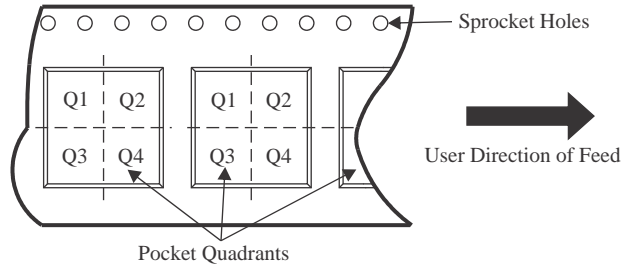
TAPE AND REEL INFORMATION

QUADRANT ASSIGNMENTS FOR PIN 1 ORIENTATION IN TAPE

*All dimensions are nominal

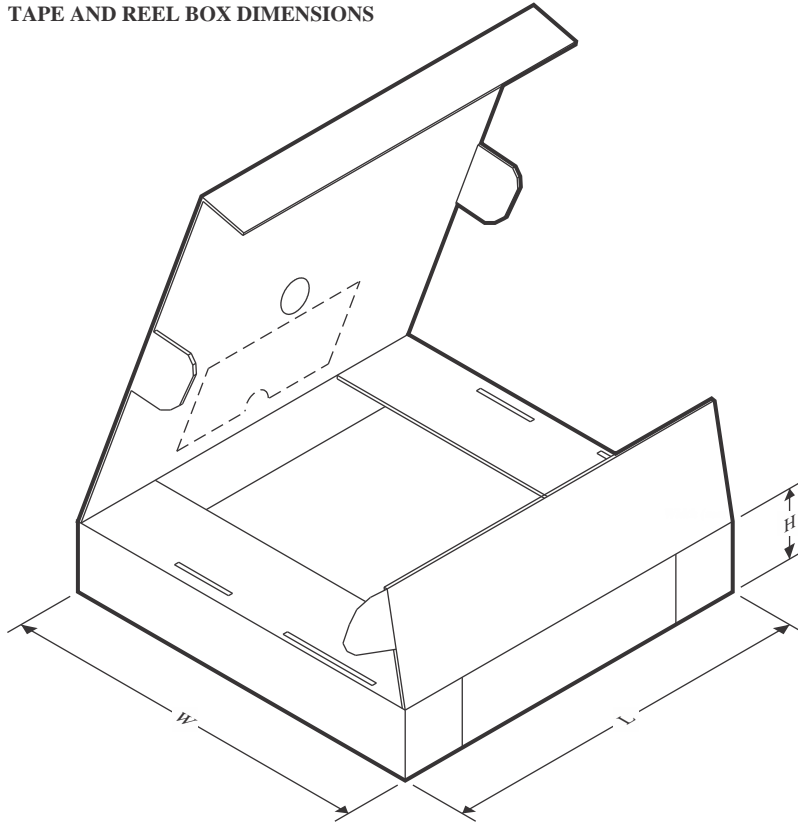
Device	Package Type	Package Drawing	Pins	SPQ	Reel Diameter (mm)	Reel Width W1 (mm)	A0 (mm)	B0 (mm)	K0 (mm)	P1 (mm)	W (mm)	Pin1 Quadrant
TPS26742EAAQRHBRQ1	VQFN	RHB	32	5000	330.0	12.4	5.3	5.3	1.1	8.0	12.0	Q2

TAPE AND REEL BOX DIMENSIONS

*All dimensions are nominal

Device	Package Type	Package Drawing	Pins	SPQ	Length (mm)	Width (mm)	Height (mm)
TPS26742EAAQRHBRQ1	VQFN	RHB	32	5000	360.0	360.0	36.0

GENERIC PACKAGE VIEW

RHB 32

VQFN - 1 mm max height

5 x 5, 0.5 mm pitch

PLASTIC QUAD FLATPACK - NO LEAD

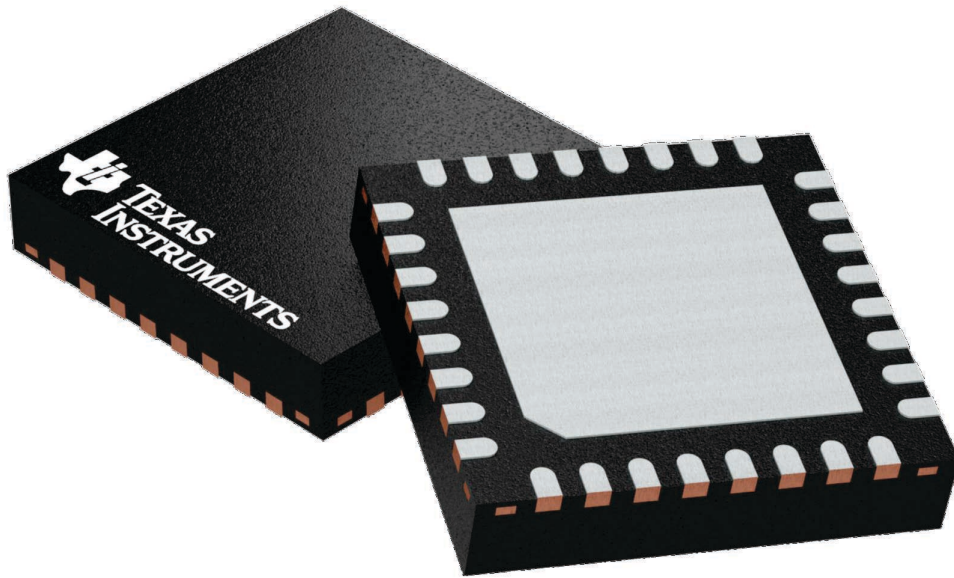

Images above are just a representation of the package family, actual package may vary.
Refer to the product data sheet for package details.

4224745/A

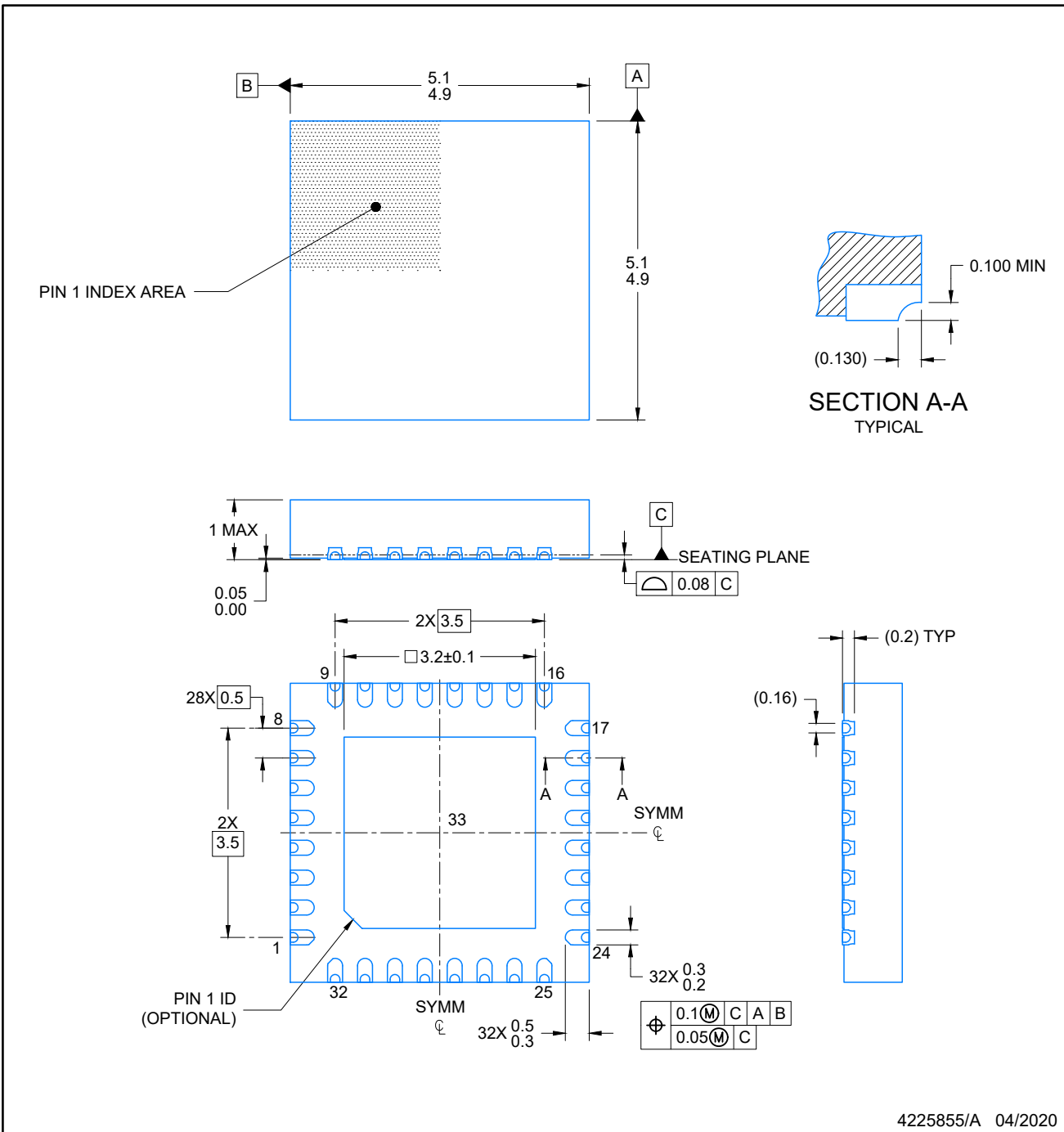

4225855/A 04/2020

NOTES:

1. All linear dimensions are in millimeters. Any dimensions in parenthesis are for reference only. Dimensioning and tolerancing per ASME Y14.5M.
2. This drawing is subject to change without notice.
3. The package thermal pad must be soldered to the printed circuit board for optimal thermal and mechanical performance.

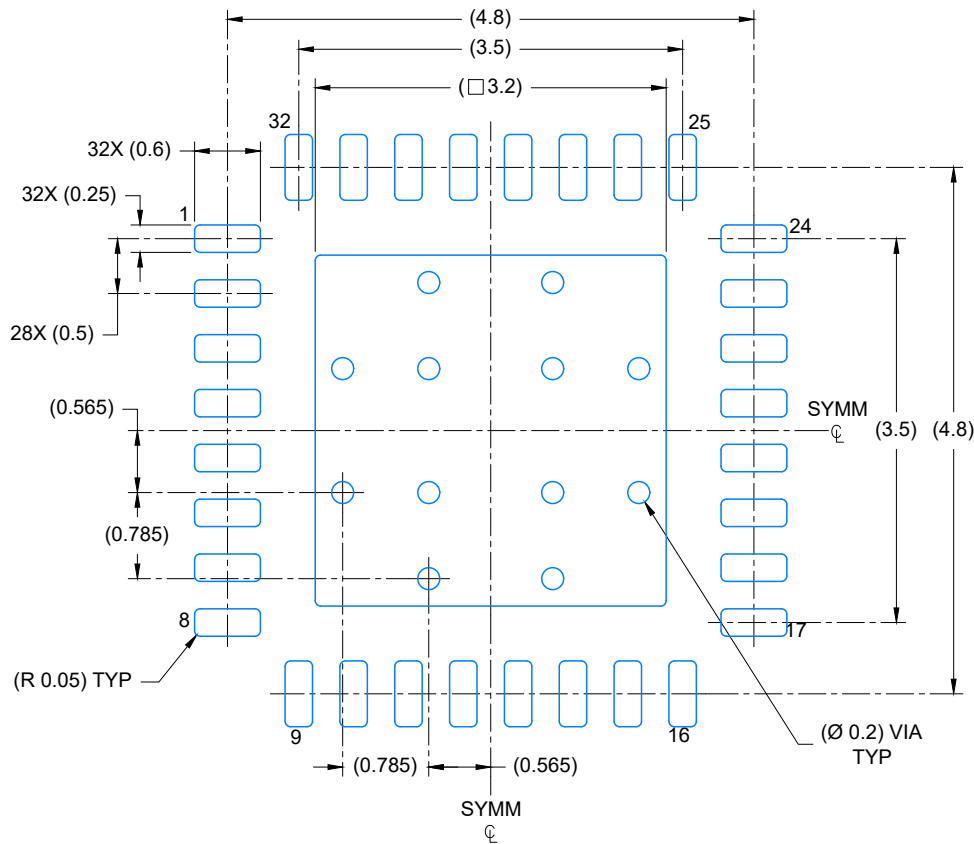

LAND PATTERN EXAMPLE
EXPOSED METAL SHOWN
SCALE: 15X

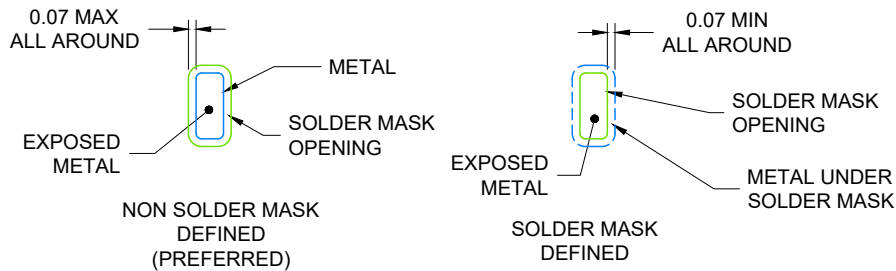

SOLDER MASK DETAILS

4225855/A 04/2020

NOTES: (continued)

4. This package is designed to be soldered to a thermal pad on the board. For more information, see Texas Instruments literature number SLUA271 (www.ti.com/lit/sluea271).
5. Vias are optional depending on application, refer to device data sheet. If any vias are implemented, refer to their locations shown on this view. It is recommended that vias under paste be filled, plugged or tented.

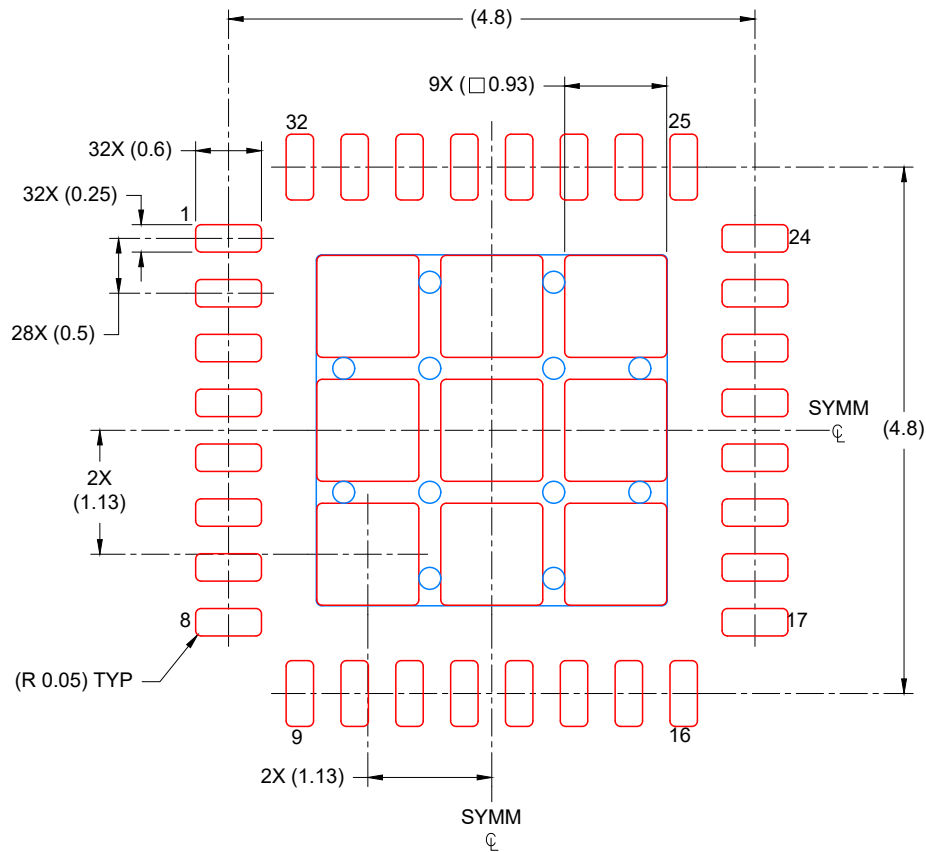

SOLDER PASTE EXAMPLE
 BASED ON 0.125 mm THICK STENCIL

EXPOSED PAD
 75% PRINTED COVERAGE BY AREA
 SCALE: 15X

4225855/A 04/2020

NOTES: (continued)

6. Laser cutting apertures with trapezoidal walls and rounded corners may offer better paste release. IPC-7525 may have alternate design recommendations.

IMPORTANT NOTICE AND DISCLAIMER

TI PROVIDES TECHNICAL AND RELIABILITY DATA (INCLUDING DATASHEETS), DESIGN RESOURCES (INCLUDING REFERENCE DESIGNS), APPLICATION OR OTHER DESIGN ADVICE, WEB TOOLS, SAFETY INFORMATION, AND OTHER RESOURCES "AS IS" AND WITH ALL FAULTS, AND DISCLAIMS ALL WARRANTIES, EXPRESS AND IMPLIED, INCLUDING WITHOUT LIMITATION ANY IMPLIED WARRANTIES OF MERCHANTABILITY, FITNESS FOR A PARTICULAR PURPOSE OR NON-INFRINGEMENT OF THIRD PARTY INTELLECTUAL PROPERTY RIGHTS.

These resources are intended for skilled developers designing with TI products. You are solely responsible for (1) selecting the appropriate TI products for your application, (2) designing, validating and testing your application, and (3) ensuring your application meets applicable standards, and any other safety, security, regulatory or other requirements.

These resources are subject to change without notice. TI grants you permission to use these resources only for development of an application that uses the TI products described in the resource. Other reproduction and display of these resources is prohibited. No license is granted to any other TI intellectual property right or to any third party intellectual property right. TI disclaims responsibility for, and you fully indemnify TI and its representatives against any claims, damages, costs, losses, and liabilities arising out of your use of these resources.

TI's products are provided subject to [TI's Terms of Sale](#), [TI's General Quality Guidelines](#), or other applicable terms available either on ti.com or provided in conjunction with such TI products. TI's provision of these resources does not expand or otherwise alter TI's applicable warranties or warranty disclaimers for TI products. Unless TI explicitly designates a product as custom or customer-specified, TI products are standard, catalog, general purpose devices.

TI objects to and rejects any additional or different terms you may propose.

Copyright © 2026, Texas Instruments Incorporated

Last updated 10/2025