

TPS31xx

Ultralow Supply-Current Voltage Monitor With Optional Watchdog

1 Features

- Precision Supply Voltage Supervision Range: 0.9V, 1.2V, 1.5V, 1.6V, 2V, and 3.3V
- High Trip-Point Accuracy: 0.75%
- Supply Current of 1.2 μ A (Typical)
- $\overline{\text{RESET}}$ Defined With Input Voltages as Low as 0.4V
- Power-On Reset Generator With a Delay Time of 130ms
- Push/Pull or Open-Drain $\overline{\text{RESET}}$ Outputs
- Package Temperature Range: -40°C to 125°C

2 Applications

- Applications Using Low-Power DSPs, Microcontrollers, or Microprocessors
- Portable and Battery-Powered Equipment
- Intelligent Instruments
- Wireless Communication Systems
- Industrial Equipment
- Notebook and Desktop Computers

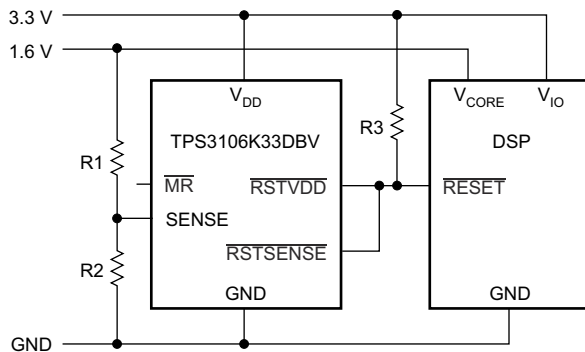

Typical Application Schematic

3 Description

The TPS310x and TPS311x families of supervisory circuits provide circuit initialization and timing supervision, primarily for DSP and processor-based systems.

During power-on, $\overline{\text{RESET}}$ is asserted low when the supply voltage (V_{DD}) becomes higher than 0.4V. Thereafter, the supervisory circuit monitors V_{DD} and keeps the $\overline{\text{RESET}}$ output low as long as V_{DD} remains below the threshold voltage ($V_{\text{IT-}}$). To provide proper system reset, after V_{DD} surpasses the threshold voltage, an internal timer delays the transition of the $\overline{\text{RESET}}$ signal from low to high for the specified time. When V_{DD} drops below $V_{\text{IT-}}$, the output transitions low again.

All the devices of this family have a fixed-sense threshold voltage ($V_{\text{IT-}}$) set by an internal voltage divider.

The TPS3103 and TPS3106 devices have an active-low, open-drain $\overline{\text{RESET}}$ output and either an integrated power-fail input (PFI) or SENSE input with corresponding outputs for monitoring other voltages. The TPS3110 has an active-low push/pull $\overline{\text{RESET}}$ and a watchdog timer to monitor the operation of microprocessors. All three devices have a manual reset pin that can be used to force the outputs low regardless of the sensed voltages.

The product spectrum is designed for supply voltages of 0.9V up to 3.6V. The circuits are available in 6-pin SOT-23 packages. The TPS31xx family is characterized for operation over a temperature range of -40°C to 125°C .

Package Information

PART NUMBER	PACKAGE ⁽¹⁾	PACKAGE SIZE ⁽²⁾
TPS3103xxx	DBV (SOT-23, 6)	2.90mm × 2.80mm
TPS3106xxx		
TPS3110xxx		

(1) For more information, see [Section 11](#).

(2) The package size (length × width) is a nominal value and includes pins, where applicable.



Table of Contents

1 Features	1	7.3 Feature Description.....	14
2 Applications	1	7.4 Device Functional Modes.....	16
3 Description	1	8 Application and Implementation	17
4 Device Comparison	3	8.1 Application Information.....	17
5 Pin Configuration and Functions	3	8.2 Typical Application.....	17
6 Specifications	4	8.3 Power Supply Recommendations.....	19
6.1 Absolute Maximum Ratings.....	4	8.4 Layout.....	19
6.2 ESD Ratings.....	4	9 Device and Documentation Support	20
6.3 Recommended Operating Conditions.....	4	9.1 Device Support.....	20
6.4 Thermal Information.....	5	9.2 Receiving Notification of Documentation Updates....	20
6.5 Electrical Characteristics.....	5	9.3 Support Resources.....	20
6.6 Timing Requirements.....	7	9.4 Trademarks.....	20
6.7 Switching Characteristics.....	7	9.5 Electrostatic Discharge Caution.....	20
6.8 Typical Characteristics.....	10	9.6 Glossary.....	20
7 Detailed Description	12	10 Revision History	21
7.1 Overview.....	12	11 Mechanical, Packaging, and Orderable Information	22
7.2 Functional Block Diagrams.....	12		

4 Device Comparison

DEVICE	RESET OUTPUT	RSTSENSE, RSTVDD OUTPUT	SENSE INPUT	WDI INPUT	PFO OUTPUT
TPS3103	Open-drain				Open-drain
TPS3106		Open-drain	✓		
TPS3110	Push-pull		✓	✓	

5 Pin Configuration and Functions

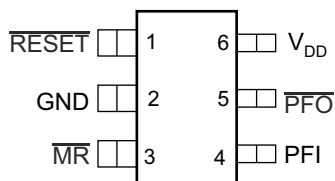

Figure 5-1. TPS3103 DBV Package 6-Pin SOT-23 Top View

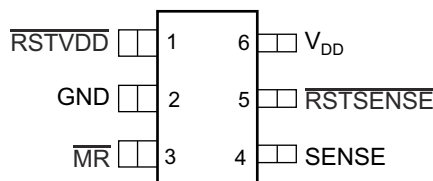

Figure 5-2. TPS3106 DBV Package 6-Pin SOT-23 Top View

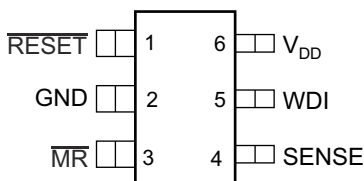

Figure 5-3. TPS3110 DBV Package 6-Pin SOT-23 Top View

Table 5-1. Pin Functions

NAME	PIN			TYPE ⁽¹⁾	DESCRIPTION
	TPS3103	TPS3106	TPS3110		
GND	2	2	2	—	GND
MR	3	3	3	I	Manual-reset input. Pull low to force a reset. RESET remains low as long as MR is low and for the time-out period after MR goes high. Leave unconnected or connect to V _{DD} when unused.
PFI	4	—	—	I	Power-fail input compares to 0.551V with no additional delay. Connect to V _{DD} if not used.
PFO	5	—	—	O	Power-fail output. Goes high when voltage at PFI rises above 0.551V.
RESET	1	—	1	O	Active-low reset output. Either push-pull or open-drain output stage.
RSTSENSE	—	5	—	O	Active-low reset output. Logic level at RSTSENSE only depends on the voltage at SENSE and the status of MR.
RSTVDD	—	1	—	O	Active-low reset output. Logic level at RSTVDD only depends on the voltage at V _{DD} and the status of MR.
SENSE	—	4	4	I	A reset is asserted if the voltage at SENSE is lower than 0.551V. Connect to V _{DD} if unused.
V _{DD}	6	6	6	I	Supply voltage. Powers the device and monitors its own voltage.
WDI	—	—	5	I	Watchdog timer input. If WDI remains high or low longer than the time-out period, then reset is triggered. The timer clears when reset is asserted or when WDI sees a rising edge or a falling edge.

(1) I = Input; O = Output

6 Specifications

6.1 Absolute Maximum Ratings

over operating junction temperature range (unless otherwise noted)⁽¹⁾

		MIN	MAX	UNIT
Supply voltage ⁽²⁾	V_{DD}	-0.3	4	V
\overline{MR} Pin, \overline{RESET} (push-pull)	$V_{\overline{MR}}$, $V_{\overline{RESET}}$ (push-pull)	-0.3	$V_{DD} + 0.3$	V
All other pins ⁽²⁾		-0.3	4	V
Maximum low output current	I_{OL}	-5	5	mA
Maximum high output current	I_{OH}	-5	5	mA
Input current	I_{IK} ($V_{SENSE} < 0V$ or $V_{SENSE} > V_{DD}$)	-10	10	mA
Output current	I_{OK} ($V_O < 0V$ or $V_O > V_{DD}$) ⁽³⁾	-10	10	mA
Continuous total power dissipation		See Thermal Information		
Temperature	Operating, T_J	-40	125	°C
	Storage, T_{stg}	-65	150	°C

- Operation outside the *Absolute Maximum Ratings* may cause permanent device damage. *Absolute Maximum Ratings* do not imply functional operation of the device at these or any other conditions beyond those listed under *Recommended Operating Conditions*. If used outside the *Recommended Operating Conditions* but within the *Absolute Maximum Ratings*, the device may not be fully functional, and this may affect device reliability, functionality, performance, and shorten the device lifetime.
- All voltage values are with respect to GND. For reliable operation, the device must not be operated at 3.6V for more than $t = 1000h$ continuously.
- Output is clamped for push-pull outputs by the back gate diodes internal to the IC. No clamp exists for the open-drain outputs.

6.2 ESD Ratings

		VALUE	UNIT
$V_{(ESD)}$ Electrostatic discharge	Human body model (HBM), per ANSI/ESDA/JEDEC JS-001, all pins ⁽¹⁾	±2000	V
	Charged device model (CDM), per JEDEC specification JESD22C101, all pins ⁽²⁾	±500	

- JEDEC document JEP155 states that 500V HBM allows safe manufacturing with a standard ESD control process.
- JEDEC document JEP157 states that 250V CDM allows safe manufacturing with a standard ESD control process.

6.3 Recommended Operating Conditions

over operating junction temperature range, unless otherwise noted.

		MIN	NOM	MAX	UNIT
V_{DD} ⁽¹⁾	Supply voltage	0.9		3.6	V
V_{SENSE}	SENSE voltage	0		V_{DD}	V
WDI, \overline{MR}	High-level input voltage V_{IH}	$0.7 \times V_{DD}$			V
WDI, \overline{MR}	Low-level input voltage V_{IL}			$0.3 \times V_{DD}$	V
WDI, \overline{MR}	Input transition rise and fall rate at $\Delta t/\Delta V$			100	ns/V
\overline{MR}	\overline{MR} voltage	0		V_{DD}	V
PFI	PFI voltage	0		3.6	V
T_J	Operating temperature	-40		125	°C

- For proper operation of SENSE, PFI, and WDI functions: $V_{DD} \geq 0.8V$.

6.4 Thermal Information

THERMAL METRIC ⁽¹⁾		TPS31xx	UNIT
		DBV (SOT-23)	
		6 PINS	
R _{θJA}	Junction-to-ambient thermal resistance	183.2	°C/W
R _{θJC(top)}	Junction-to-case (top) thermal resistance	123.3	°C/W
R _{θJB}	Junction-to-board thermal resistance	29.4	°C/W
ψ _{JT}	Junction-to-top characterization parameter	20.5	°C/W
ψ _{JB}	Junction-to-board characterization parameter	29	°C/W

(1) For more information about traditional and new thermal metrics, see the [Semiconductor and IC Package Thermal Metrics](#) application note.

6.5 Electrical Characteristics

over operating junction temperature range (unless otherwise noted).

PARAMETER		TEST CONDITIONS	MIN	TYP	MAX	UNIT		
V _{OH}	High-level output voltage	V _{DD} = 3.3V, I _{OH} = –3mA	0.8 × V _{DD}			V		
		V _{DD} = 1.8V, I _{OH} = –2mA						
		V _{DD} = 1.5V, I _{OH} = –1mA						
		V _{DD} = 0.9V, I _{OH} = –0.4mA						
		V _{DD} = 0.5V, I _{OH} = –5μA					0.7 × V _{DD}	
V _{OL}	Low-level output voltage	V _{DD} = 3.3V, I _{OL} = 3mA			0.3	V		
		V _{DD} = 1.5V, I _{OL} = 2mA						
		V _{DD} = 1.2V, I _{OL} = 1mA						
		V _{DD} = 0.9V, I _{OL} = 500μA						
V _{OL}	Low-level output voltage	RESET only	V _{DD} = 0.4V, I _{OL} = 5μA			0.1	V	
V _{IT–}	Negative-going input threshold voltage ⁽¹⁾	TPS31xxE09	T _A = 25°C	0.854	0.86	0.866	V	
		TPS31xxE12		1.133	1.142	1.151		
		TPS31xxE15		1.423	1.434	1.445		
		TPS31xxE16		1.512	1.523	1.534		
		TPS31xxH20		1.829	1.843	1.857		
		TPS31xxK33		2.919	2.941	2.963		
		TPS31xxE09		T _A = –40°C to 125°C	0.817			0.903
		TPS31xxE12			1.084			1.199
		TPS31xxE15			1.362			1.505
		TPS31xxK33			2.823			3.058
V _{IT–(S)}	Negative-going input threshold voltage ⁽¹⁾	SENSE, PFI	V _{DD} ≥ 0.8V, T _A = 25°C	0.542	0.551	0.559	V	
			V _{DD} ≥ 0.8V, T _A = –40°C to 125°C	0.5		0.58		
V _{HYS}	Hysteresis at V _{DD} input		0.8V ≤ V _{IT–} < 1.5V		20	mV		
			1.6V ≤ V _{IT–} < 2.4V		30			
			2.5V ≤ V _{IT–} < 3.3V		50			
T _(K)	Temperature coefficient of V _{IT–} , PFI, SENSE	T _A = –40°C to 85°C		–0.012	–0.019	%/K		
V _{HYS(S)}	Hysteresis at SENSE, PFI input	V _{DD} ≥ 0.8V		15		mV		
I _{IH}	High-level input current	MR	M _R = V _{DD} , V _{DD} = 3.3V	–25		25	nA	
		SENSE, PFI, WDI	SENSE, PFI, WDI = V _{DD} , V _{DD} = 3.3V	–25		25		

6.5 Electrical Characteristics (continued)

over operating junction temperature range (unless otherwise noted).

PARAMETER		TEST CONDITIONS	MIN	TYP	MAX	UNIT	
I _{IL}	Low-level input current	MR	MR = 0V, V _{DD} = 3.3V	-47	-33	-25	μA
		SENSE, PFI, WDI	SENSE, PFI, WDI = 0V, V _{DD} = 3.3V	-25		25	nA
I _{OH}	High-level output current at RESET (2)	Open-drain	V _{DD} = V _{IT-} + 0.2V, V _{OH} = 3.3V			200	nA
I _{DD}	Supply current		T _A = -40°C to 85°C, V _{DD} > V _{IT-} (average current), V _{DD} < 1.8V		1.2	3	μA
			T _A = -40°C to 125°C, V _{DD} > V _{IT-} (average current), V _{DD} < 1.8V			3	
			T _A = -40°C to 85°C, V _{DD} > V _{IT-} (average current), V _{DD} > 1.8V		2	4.5	
			T _A = -40°C to 125°C, V _{DD} > V _{IT-} (average current), V _{DD} > 1.8V			5.5	
			T _A = -40°C to 85°C, V _{DD} < V _{IT-} , V _{DD} < 1.8V			22	
			T _A = -40°C to 125°C, V _{DD} < V _{IT-} , V _{DD} < 1.8V			27	
			T _A = -40°C to 85°C, V _{DD} < V _{IT-} , V _{DD} > 1.8V			27	
			T _A = -40°C to 125°C, V _{DD} < V _{IT-} , V _{DD} > 1.8V			32	
Internal pullup resistor at MR			70	100	130	kΩ	
C _{IN}	Input capacitance at MR, SENSE, PFI, WDI	V _{IN} = 0V to V _{DD}		1		pF	

- (1) To provide the best stability of the threshold voltage, a bypass capacitor (ceramic, 0.1μF) must be placed close to the supply terminals.
 (2) Also refers to RSTVDD and RSTSENSE.

6.6 Timing Requirements

At $R_L = 1\text{M}\Omega$, $C_L = 50\text{pF}$, and $T_A = -40^\circ\text{C}$ to 85°C , unless otherwise noted.

				MIN	TYP	MAX	UNIT
$t_{T(\text{OUT})}$	Time-out period	at WDI	$V_{DD} \geq 0.85\text{V}$	0.55	1.1	1.65	s
t_W	Pulse duration	at V_{DD}	$V_{IH} = 1.1 \times V_{IT-}$, $V_{IL} = 0.9 \times V_{IT-}$, $V_{IT-} = 0.86\text{V}$	20			μs
		at MR	$V_{DD} \geq V_{IT-} + 0.2\text{V}$, $V_{IL} = 0.3 \times V_{DD}$, $V_{IH} = 0.7 \times V_{DD}$	0.1			
		at SENSE	$V_{DD} \geq V_{IT-}$, $V_{IH} = 1.1 \times V_{IT-(S)}$, $V_{IL} = 0.9 \times V_{IT-(S)}$	20			
		at PFI	$V_{DD} \geq 0.85\text{V}$, $V_{IH} = 1.1 \times V_{IT-(S)}$, $V_{IL} = 0.9 \times V_{IT-(S)}$	20			
		at WDI	$V_{DD} \geq V_{IT-}$, $V_{IL} = 0.3 \times V_{DD}$, $V_{IH} = 0.7 \times V_{DD}$	0.3			

6.7 Switching Characteristics

At $R_L = 1\text{M}\Omega$, $C_L = 50\text{pF}$, and $T_A = -40^\circ\text{C}$ to 85°C , unless otherwise noted.

PARAMETER		TEST CONDITIONS	MIN	TYP	MAX	UNIT
t_D	Delay time	$V_{DD} \geq 1.1 \times V_{IT-}$, $\overline{\text{MR}} = 0.7 \times V_{DD}$. See Timing Requirements .	65	130	195	ms
$t_{\text{PHL}(V_{DD})}$	Propagation delay time, high-to-low level output	V_{DD} to RESET or RSTVDD delay			40	μs
$t_{\text{PHL}(\text{SENSE})}$	Propagation delay time, high-to-low level output	SENSE to RESET or RSTSENSE delay	$V_{DD} \geq 0.8\text{V}$, $V_{IH} = 1.1 \times V_{IT-}$, $V_{IL} = 0.9 \times V_{IT-}$		40	μs
$t_{\text{PHL}(\text{PFI})}$	Propagation delay time, high-to-low level output	PFI to $\overline{\text{PFO}}$ delay	$V_{DD} \geq 0.8\text{V}$, $V_{IH} = 1.1 \times V_{IT-}$, $V_{IL} = 0.9 \times V_{IT-}$		40	μs
$t_{\text{PLH}(\text{PFO})}$	Propagation delay time, low-to-high level output	PFI to $\overline{\text{PFO}}$ delay	$V_{DD} \geq 0.8\text{V}$, $V_{IH} = 1.1 \times V_{IT-}$, $V_{IL} = 0.9 \times V_{IT-}$		300	μs
$t_{\text{PHL}(\text{MR})}$	Propagation delay time, high-to-low level output	MR to RESET, RSTVDD, RSTSENSE delay	$V_{DD} \geq 1.1 \times V_{IT-}$, $V_{IL} = 0.3 \times V_{DD}$, $V_{IH} = 0.7 \times V_{DD}$	1	5	μs

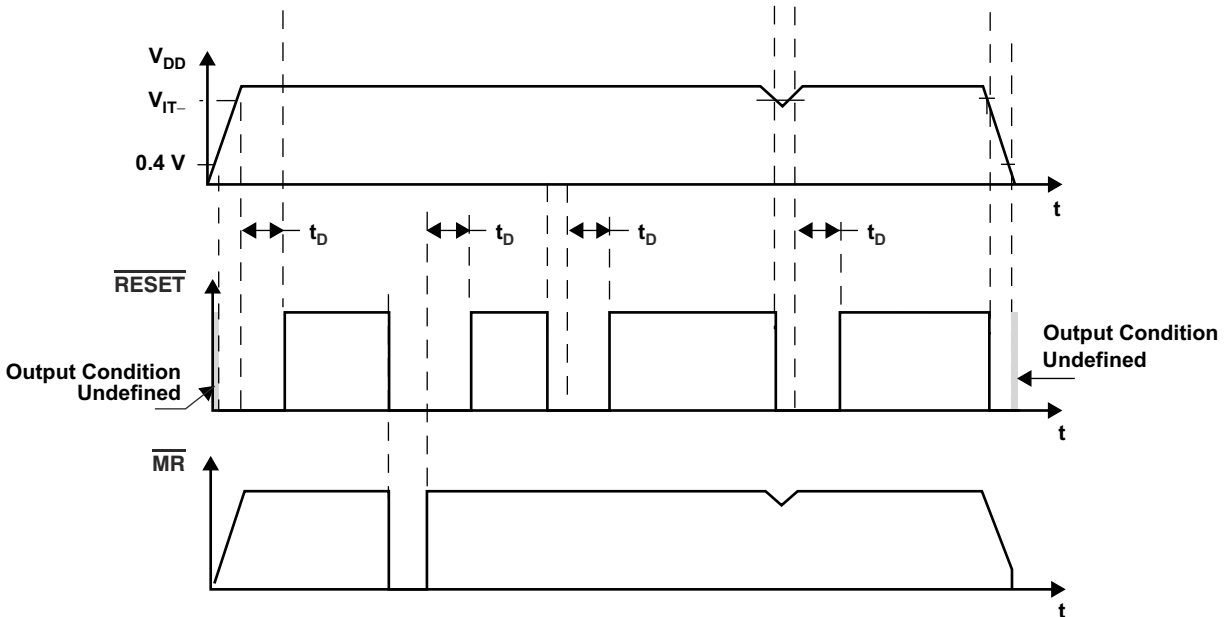

Figure 6-1. RESET Timing Diagram for TPS3103

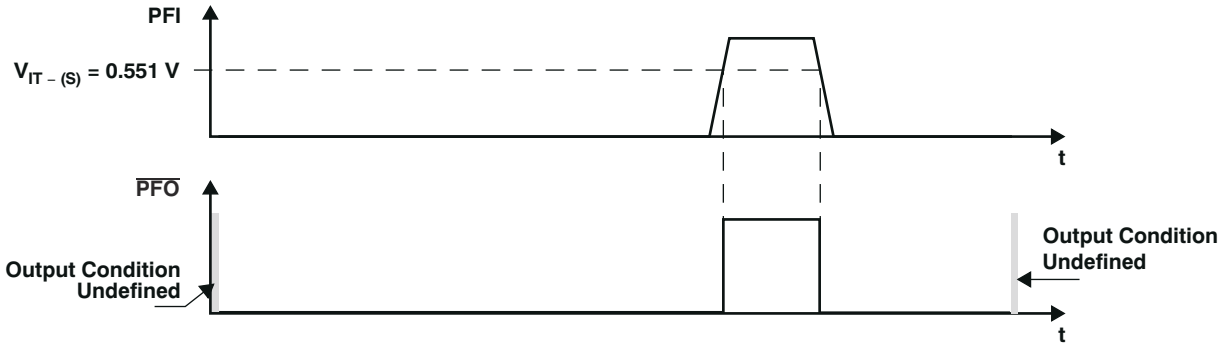

Figure 6-2. $\overline{\text{PFO}}$ Timing Diagram for TPS3103

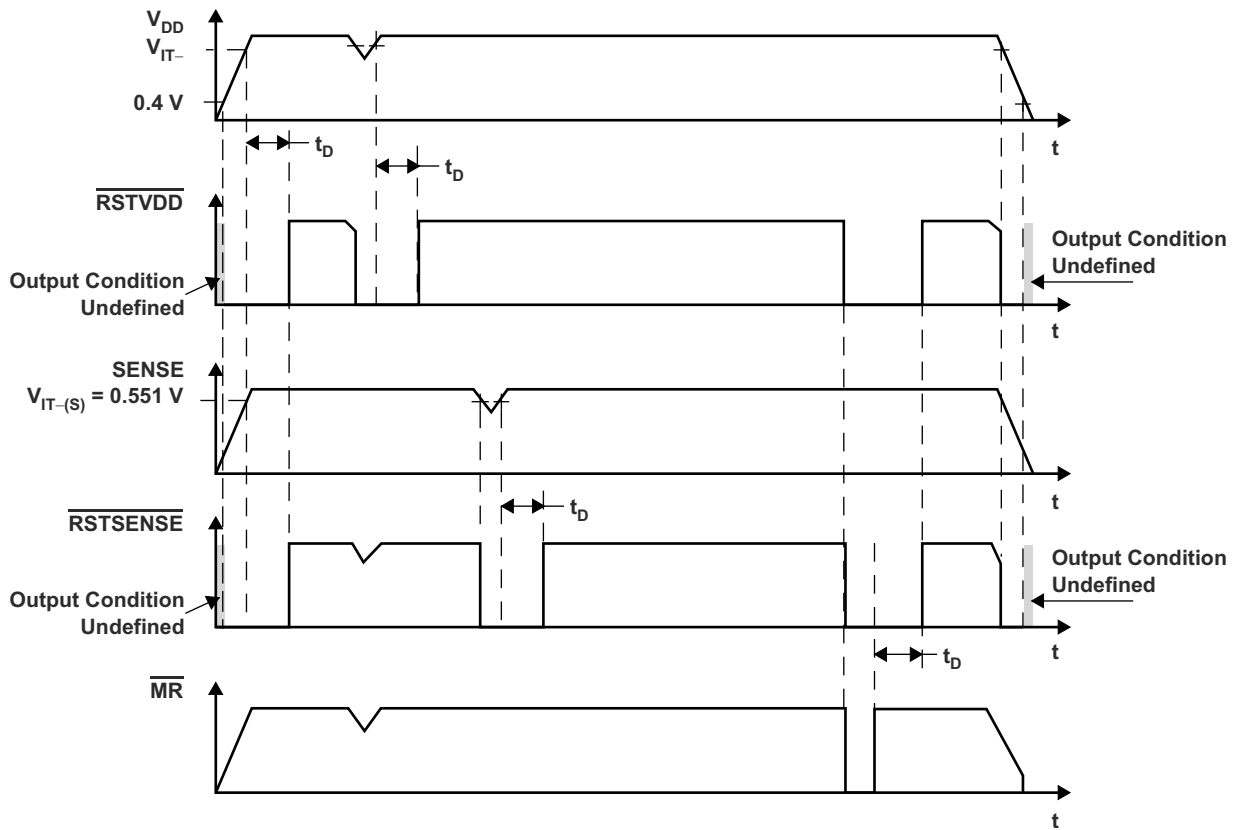

Figure 6-3. Timing Diagram for TPS3106

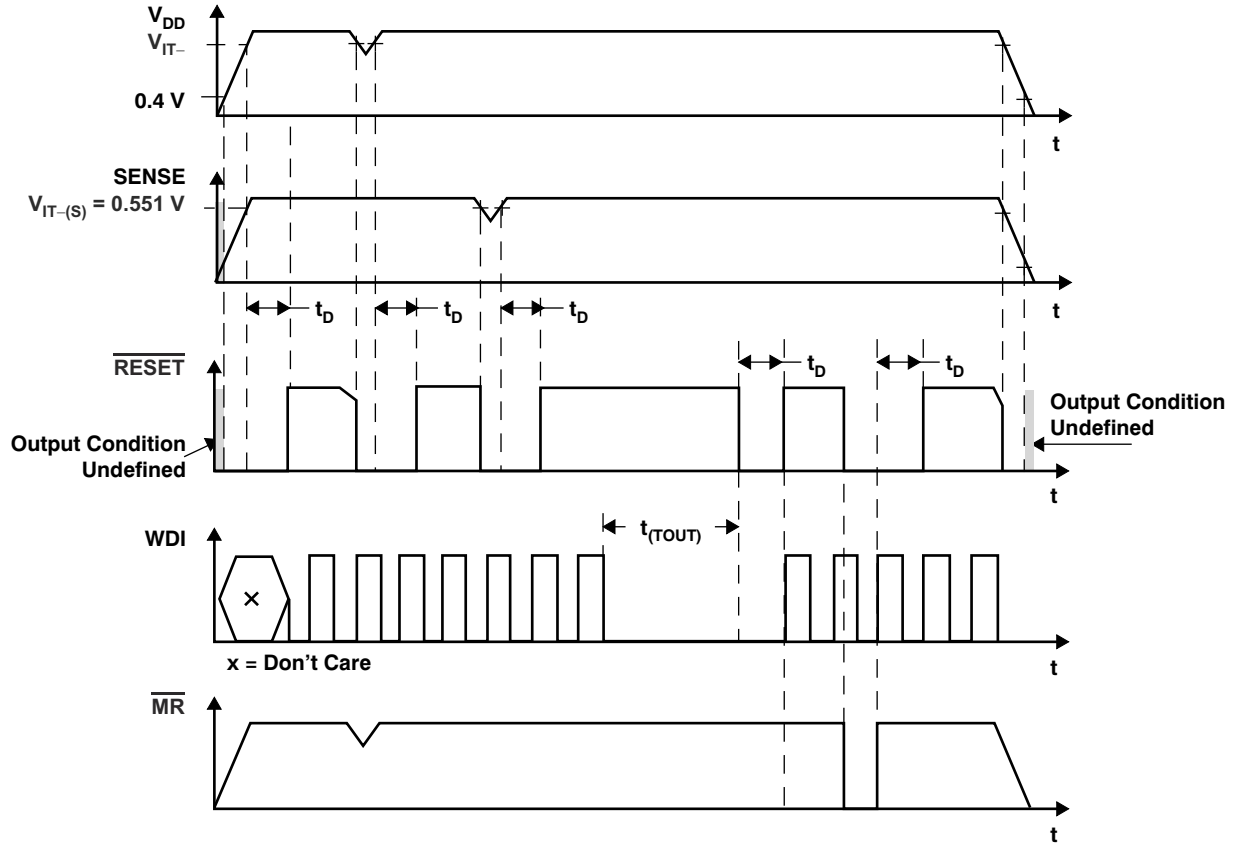
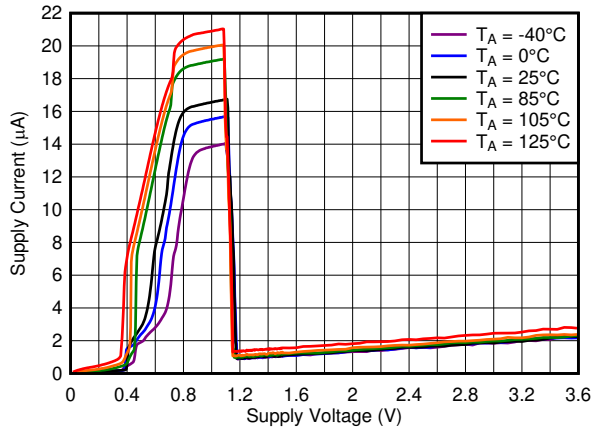

Figure 6-4. Timing Diagram for TPS3110

6.8 Typical Characteristics



SENSE = V_{DD} , \overline{MR} = open, \overline{RESET} = open, WDI: triggered

Figure 6-5. TPS3110E09 Supply Current vs Supply Voltage

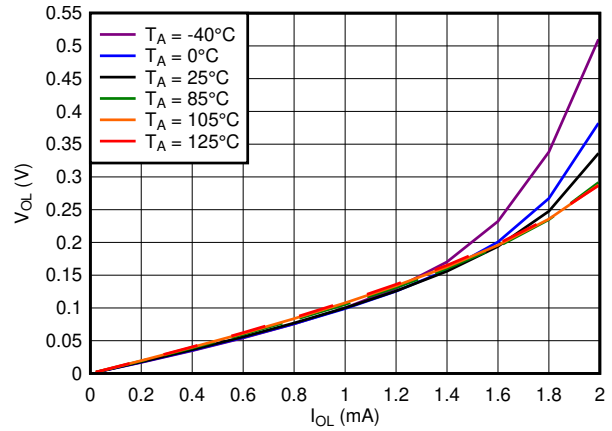

V_{DD} = 0.9V, SENSE = GND, \overline{MR} = GND, WDI: GND

Figure 6-6. TPS3110E09 Low-Level Output Voltage vs Low-Level Output Current

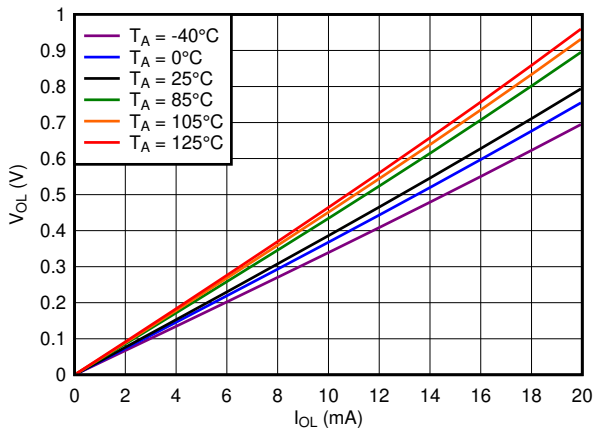

V_{DD} = 3.3V, SENSE = GND, \overline{MR} = GND, WDI: GND

Figure 6-7. TPS3110E09 Low-Level Output Voltage vs Low-Level Output Current

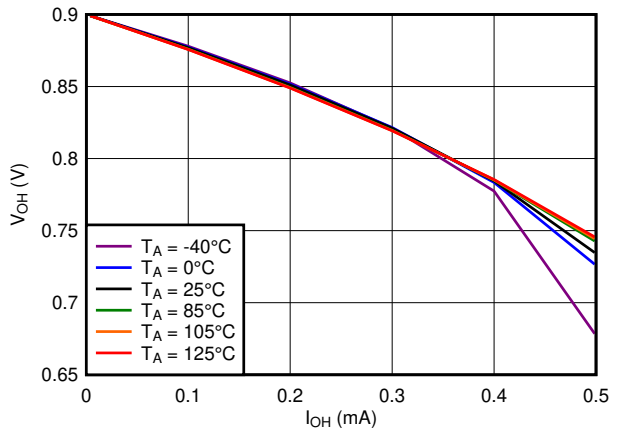

V_{DD} = 0.9V, SENSE = V_{DD} , \overline{MR} = V_{DD} , WDI: triggered

Figure 6-8. TPS3110E09 High-Level Output Voltage vs High-Level Output Current

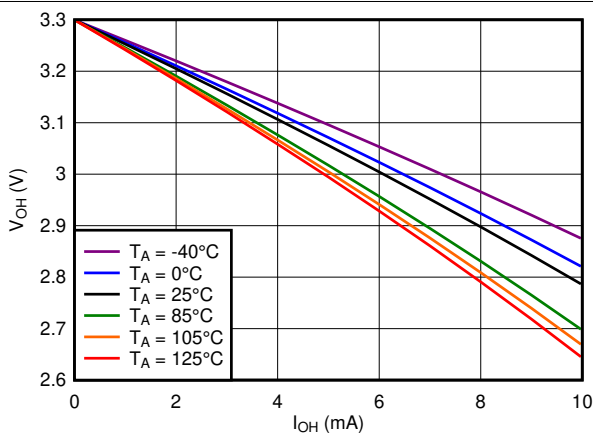

V_{DD} = 3.3V, SENSE = V_{DD} , \overline{MR} = V_{DD} , WDI: triggered

Figure 6-9. TPS3110K33 High-Level Output Voltage vs High-Level Output Current

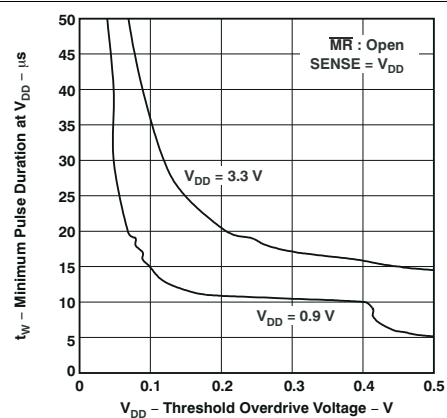

Figure 6-10. Minimum Pulse Duration at V_{DD} vs Threshold Overdrive Voltage

6.8 Typical Characteristics (continued)

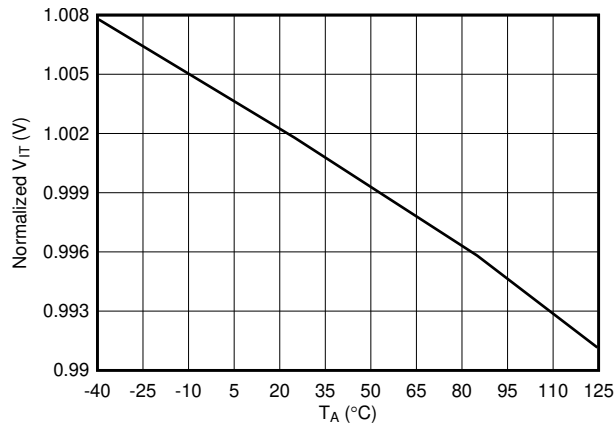

Figure 6-11. Normalized Threshold Voltage vs Free-Air Temperature

7 Detailed Description

7.1 Overview

The TPS310x and TPS311x families of supervisory circuits operate from supply voltages from 0.9V to 3.6V and provide circuit initialization and timing supervision for DSP- and processor-based systems. During power-on, $\overline{\text{RESET}}$ is asserted when the supply voltage (V_{DD}) exceeds 0.4V. The devices monitor V_{DD} and keep the $\overline{\text{RESET}}$ output low as long as V_{DD} remains below the threshold voltage ($V_{\text{IT-}}$). To verify proper system reset, after V_{DD} surpasses the threshold voltage plus the hysteresis ($V_{\text{IT-}} + V_{\text{HYS}}$) an internal timer delays the transition of the $\overline{\text{RESET}}$ signal from low to high for the specified time. The delay time starts after V_{DD} has risen above ($V_{\text{IT-}} + V_{\text{HYS}}$). When V_{DD} drops below $V_{\text{IT-}}$, the output becomes active again.

All the devices of this family have a fixed- V_{DD} threshold voltage ($V_{\text{IT-}}$) set by an internal voltage divider. The TPS3103 and TPS3106 devices both have an active-low, open-drain $\overline{\text{RESET}}$ output. The TPS3103 device has an integrated power-fail input (PFI) and corresponding power-fail output ($\overline{\text{PFO}}$) that can be used for low-battery detection or for monitoring a power supply other than the input supply. The TPS3106 device has a SENSE input with a corresponding output ($\overline{\text{RSTSENSE}}$) for monitoring voltages other than the input supply. The TPS3110 device has an active-low push/pull $\overline{\text{RESET}}$ and a watchdog timer that is used for monitoring the operation of microprocessors. All three devices have manual reset pin ($\overline{\text{MR}}$) that can be used to force the outputs low regardless of the sensed voltages.

7.2 Functional Block Diagrams

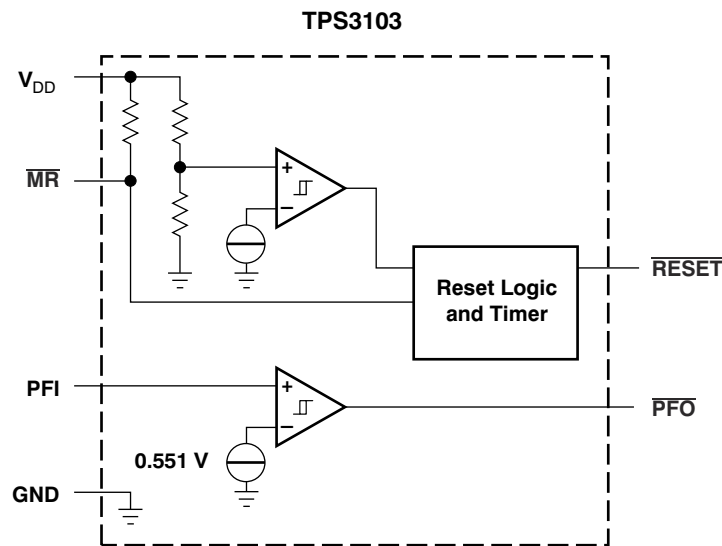

Figure 7-1. TPS3103 Functional Block Diagram

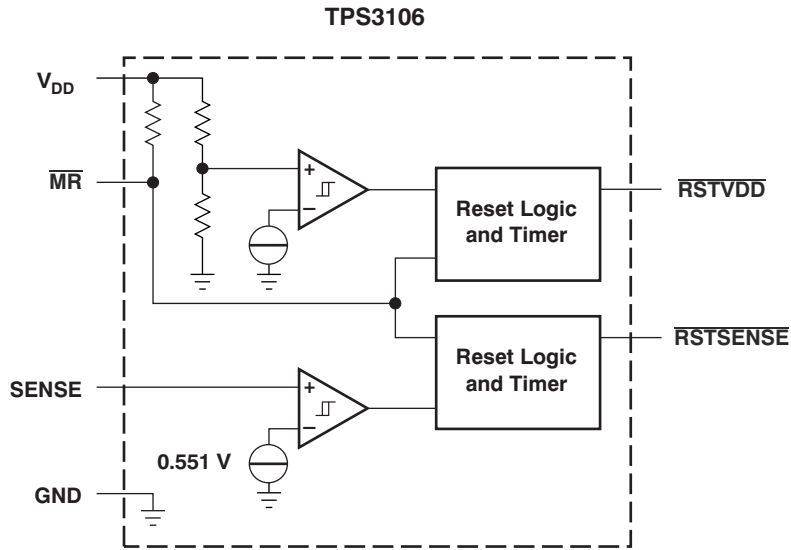

Figure 7-2. TPS3106 Functional Block Diagram

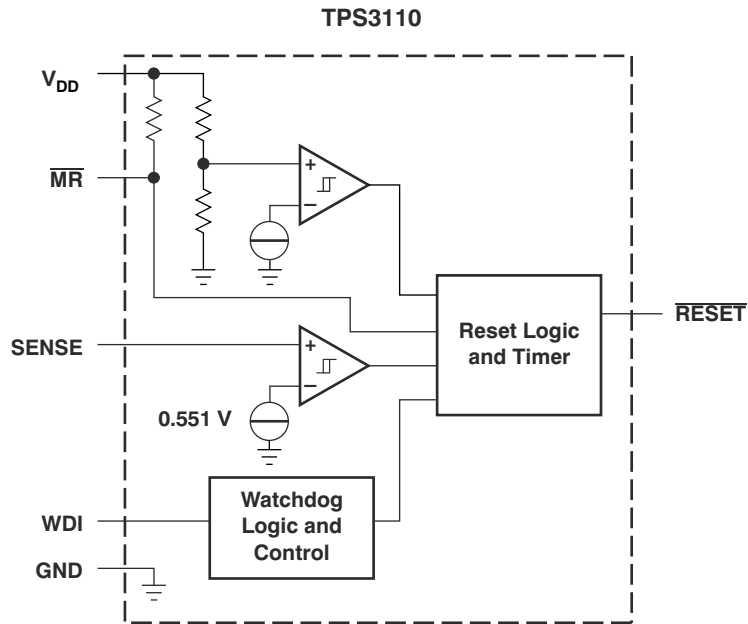

Figure 7-3. TPS3110 Functional Block Diagram

7.3 Feature Description

7.3.1 Watchdog

The TPS3110 device integrates a watchdog timer that must be periodically triggered by a positive or negative transition of WDI. When the supervising system fails to retrigger the watchdog circuit within the time-out interval, $\overline{\text{RESET}}$ becomes active for the time period (t_D). This event also reinitializes the watchdog timer.

7.3.2 Manual Reset ($\overline{\text{MR}}$)

Many μC -based products require manual-reset capability, allowing an operator or logic circuitry to initiate a reset. Logic low at $\overline{\text{MR}}$ asserts reset. Reset remains asserted while $\overline{\text{MR}}$ is low and for a time period (t_D) after $\overline{\text{MR}}$ returns high. The input has an internal 100k Ω pullup resistor, so input can be left open if the input is unused.

Connect a normally open momentary switch from $\overline{\text{MR}}$ to GND to create a manual reset function. External debounce is not required. If $\overline{\text{MR}}$ is driven from long cables or if the device is used in noisy environments, connecting a 0.1 μF capacitor from $\overline{\text{MR}}$ to GND provides additional noise immunity.

If there is a possibility of transient or DC conditions causing $\overline{\text{MR}}$ to rise above V_{DD} , a diode must be used to limit $\overline{\text{MR}}$ to a diode drop above V_{DD} .

7.3.3 PFI, $\overline{\text{PFO}}$

The TPS3103 has an integrated power-fail (PFI) comparator with a separate open-drain ($\overline{\text{PFO}}$) output. The PFI and $\overline{\text{PFO}}$ can be used for low-battery detection, power-fail warning, or for monitoring a power supply other than the main supply, and has no effect on $\overline{\text{RESET}}$.

An additional comparator is provided to monitor voltages other than the nominal supply voltage. The power-fail input (PFI) is compared with an internal voltage reference of 0.551V. If the input voltage falls below the power-fail threshold ($V_{IT(S)}$), the power-fail output ($\overline{\text{PFO}}$) goes low. If the input voltage goes above 0.551V plus approximately 15mV hysteresis, the output returns to high. To supervise any voltage above 0.551V, connect two external resistors. The sum of both resistors must be approximately 1M Ω , to minimize power consumption and to verify that the current into the PFI pin can be neglected, compared with the current through the resistor network. The tolerance of the external resistors must be not more than 1% to provide minimal variation of sensed voltage. If the power-fail comparator is unused, connect PFI to GND and leave $\overline{\text{PFO}}$ unconnected. For proper operation of the PFI-comparator, the supply voltage (V_{DD}) must be higher than 0.8V.

7.3.4 SENSE

The voltage at the SENSE input is compared with a reference voltage of 0.551V. If the voltage at SENSE falls below the sense-threshold ($V_{IT(S)}$), reset is asserted. On the TPS3106 device, a dedicated $\overline{\text{RSTSENSE}}$ output is available. On the TPS3110 device, the logic signal from SENSE is OR-wired with the logic signal from V_{DD} or $\overline{\text{MR}}$. An internal timer delays the return of the output to the inactive state, once the voltage at SENSE goes above 0.551 V plus about 15mV of hysteresis. For proper operation of the SENSE-comparator, the supply voltage must be higher than 0.8V.

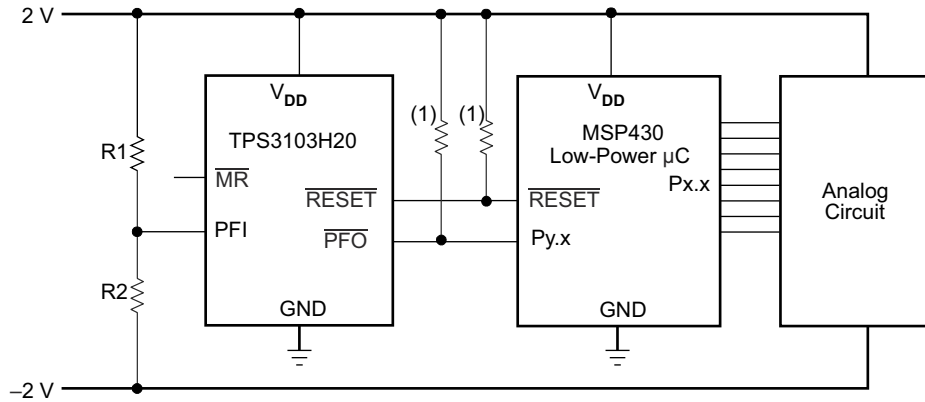

$$V_{(NEG_TH)} = 0.551 \text{ V} - \frac{R2}{R1} (V_{DD} - 0.551 \text{ V})$$

A. Resistor can be integrated in microcontroller.

Figure 7-4. TPS3103 Monitoring a Negative Voltage

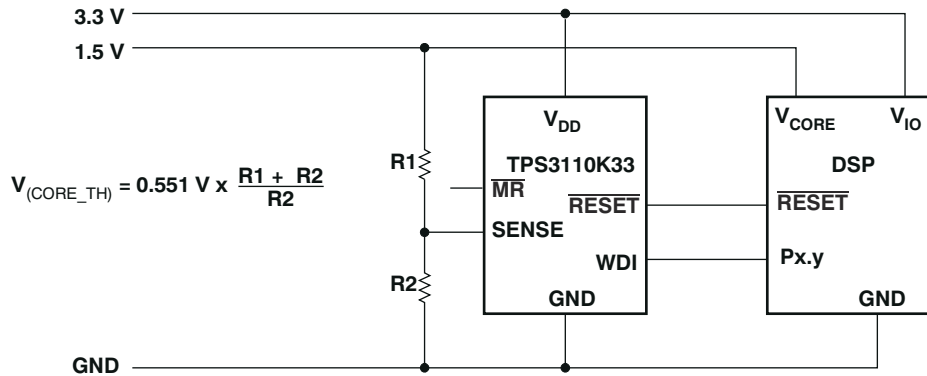

Figure 7-5. TPS3110 in a DSP-System Monitoring Both Supply Voltages

7.4 Device Functional Modes

Table 7-1. TPS3103 Function Table

MR	$V_{(PFI)} > 0.551V$	$V_{DD} > V_{IT-}$	RESET	PFO
L	0	X ⁽¹⁾	L	L
L	1	X	L	H
H	0	0	L	L
H	0	1	H	L
H	1	0	L	H
H	1	1	H	H

(1) X = Don't care.

Table 7-2. TPS3106 Function Table

MR	$V_{(SENSE)} > 0.551V$	$V_{DD} > V_{IT-}$	RSTVDD	RSTSENSE
L	X ⁽¹⁾	X	L	L
H	0	0	L	L
H	0	1	H	L
H	1	0	L	H
H	1	1	H	H

(1) X = Don't care.

Table 7-3. TPS3110 Function Table ⁽¹⁾

MR	$V_{(SENSE)} > 0.551V$	$V_{DD} > V_{IT-}$	RESET
L	X ⁽²⁾	X	L
H	0	0	L
H	0	1	L
H	1	0	L
H	1	1	H

(1) Function of watchdog timer not shown.

(2) X = Don't care.

8 Application and Implementation

Note

Information in the following applications sections is not part of the TI component specification, and TI does not warrant its accuracy or completeness. TI's customers are responsible for determining suitability of components for their purposes, as well as validating and testing their design implementation to confirm system functionality.

8.1 Application Information

The TPS310x and TPS311x families are supervisory circuits made to monitor the input supply and other external voltages greater than 0.551V. These devices are made to operate from and monitor input supplies ranging from 0.9V to 3.6 V, and all versions have a manual reset pin. The TPS3103 and TPS3106 both have an active-low, open-drain RESET output. The TPS3103 device has an integrated power-fail input (PFI) and corresponding power-fail output ($\overline{\text{PFO}}$) that can be used for low-battery detection or for monitoring a power supply other than the input supply and has a short delay time for more immediate triggering of the output. The TPS3106 device has a SENSE input with a corresponding output ($\overline{\text{RSTSENSE}}$) for monitoring voltages other than the input supply and a longer delay time than the TPS3103 device to minimize accidental triggering of the output. The TPS3110 device has an active-low push/pull $\overline{\text{RESET}}$ and a watchdog timer that is used for monitoring the operation of microprocessors.

8.2 Typical Application

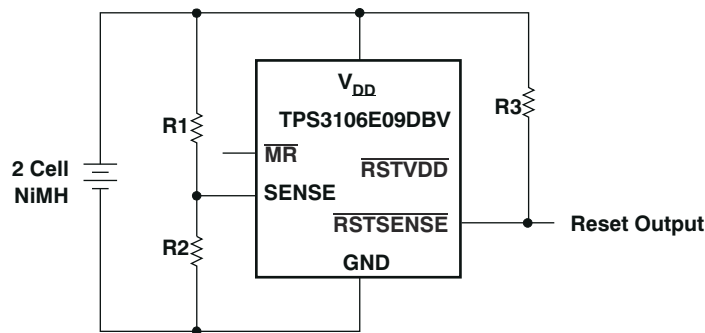

Figure 8-1. Battery Monitoring With 3 μ A Supply Current for Device and Resistor Divider

8.2.1 Design Requirements

In some applications, minimizing the quiescent current is necessary, even during the reset period. This is especially true when the voltage of a battery is supervised and the $\overline{\text{RESET}}$ is used to shut down the system or for an early warning. In this case the reset condition lasts for a longer period of time. The current drawn from the battery is close to zero, especially when the battery is discharged.

For this kind of application, either the TPS3103 or TPS3106 device is a good fit. To minimize current consumption, select a version where the threshold voltage is lower than the voltage monitored at V_{DD} . The TPS3106 device has two reset outputs. One output ($\overline{\text{RSTVDD}}$) is triggered from the voltage monitored at V_{DD} . The other output ($\overline{\text{RSTSENSE}}$) is triggered from the voltage monitored at SENSE. In the application shown in [Figure 8-1](#), the TPS3106E09 device is used to monitor the input voltage of two NiCd or NiMH cells. The threshold voltage [$V_{(\text{TH})} = 0.86\text{V}$] is chosen as low as possible to verify that the supply voltage is always higher than the threshold voltage at V_{DD} . The voltage of the battery is monitored using the SENSE input.

8.2.2 Detailed Design Procedure

The voltage divider is calculated to assert a reset using the $\overline{\text{RSTSENSE}}$ output at $2 \times 0.8\text{V} = 1.6\text{V}$, using Equation 1.

$$R_1 = R_2 \times \left[\frac{V_{\text{TRIP}}}{V_{\text{IT-(S)}}} - 1 \right] \tag{1}$$

where

- V_{TRIP} is the voltage of the battery at which a reset is asserted
- $V_{\text{IT-(S)}}$ is the threshold voltage at $\text{SENSE} = 0.551\text{V}$
- R_1 is chosen for a resistor current in the $1\mu\text{A}$ range
- With $V_{\text{TRIP}} = 1.6\text{V}$
- $R_1 \cong 1.9 \times R_2$
- $R_1 = 820\text{k}\Omega$, $R_2 = 430\text{k}\Omega$

8.2.3 Application Curve

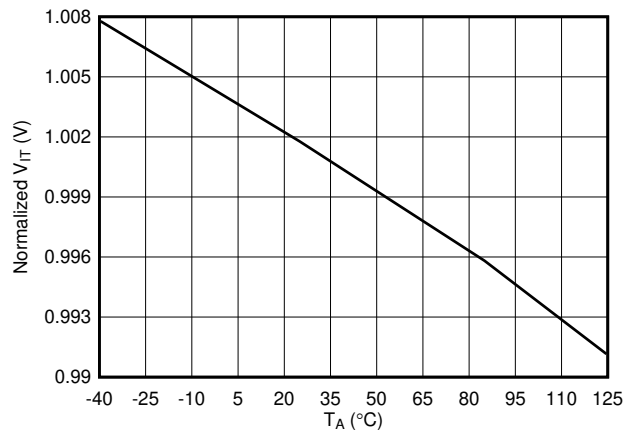

Figure 8-2. Normalized Threshold Voltage vs Free-Air Temperature

8.3 Power Supply Recommendations

These devices are designed to operate from an input supply with a voltage range between 0.9V and 3.6V.

Though not required, placing a 0.1µF ceramic capacitor close to the VCC pin if the input supply is noisy is good analog design practice.

8.4 Layout

8.4.1 Layout Guidelines

Follow these guidelines to lay out the printed-circuit-board (PCB) that is used for the TPS310x and TPS3110x family of devices.

- Place the V_{DD} decoupling capacitor close to the device.
- Avoid using long traces for the VCC supply node. The VCC capacitor (C_{VDD}), along with parasitic inductance from the supply to the capacitor, can form an LC tank and create ringing with peak voltages above the maximum V_{DD} voltage.

8.4.2 Layout Example

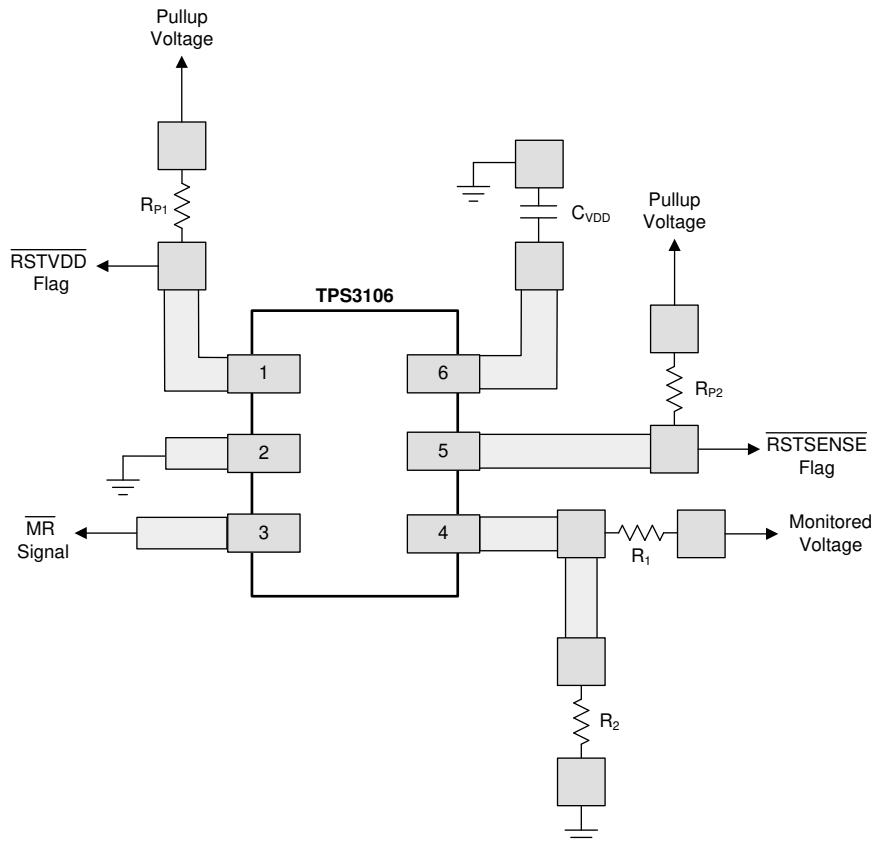

Figure 8-3. Example Layout (DBV Package)

9 Device and Documentation Support

9.1 Device Support

9.1.1 Development Support

9.1.1.1 Spice Models

Computer simulation of circuit performance using SPICE is often useful when analyzing the performance of analog circuits and systems. SPICE models for the TPS310x and TPS311x are available through the respective product folders under *Tools & Software*.

9.1.2 Device Nomenclature

Table 9-1. Ordering Information ⁽¹⁾

PRODUCT	NOMINAL SUPPLY VOLTAGE	THRESHOLD VOLTAGE, V_{IT-} ⁽²⁾
TPS3103E12DBVR	1.2V	1.142V
TPS3103E15DBVR	1.5V	1.434V
TPS3103H20DBVR	2.0V	1.84V
TPS3103K33DBVR	3.3V	2.941V
TPS3106E09DBVR	0.9V	0.86V
TPS3106E16DBVR	1.6V	1.521V
TPS3106K33DBVR	3.3V	2.941V
TPS3110E09DBVR	0.9V	0.86V
TPS3110E12DBVR	1.2V	1.142V
TPS3110E15DBVR	1.5V	1.434V
TPS3110K33DBVR	3.3V	2.941V

- (1) For the most current package and ordering information see the Package Option Addendum at the end of this document, or see the TI website at www.ti.com.
 (2) Custom threshold voltages are available. Minimum order quantities apply. Contact factory for details and availability.

9.2 Receiving Notification of Documentation Updates

To receive notification of documentation updates, navigate to the device product folder on ti.com. Click on *Notifications* to register and receive a weekly digest of any product information that has changed. For change details, review the revision history included in any revised document.

9.3 Support Resources

[TI E2E™ support forums](#) are an engineer's go-to source for fast, verified answers and design help — straight from the experts. Search existing answers or ask your own question to get the quick design help you need.

Linked content is provided "AS IS" by the respective contributors. They do not constitute TI specifications and do not necessarily reflect TI's views; see TI's [Terms of Use](#).

9.4 Trademarks

TI E2E™ is a trademark of Texas Instruments.
 All trademarks are the property of their respective owners.

9.5 Electrostatic Discharge Caution



This integrated circuit can be damaged by ESD. Texas Instruments recommends that all integrated circuits be handled with appropriate precautions. Failure to observe proper handling and installation procedures can cause damage.

ESD damage can range from subtle performance degradation to complete device failure. Precision integrated circuits may be more susceptible to damage because very small parametric changes could cause the device not to meet its published specifications.

9.6 Glossary

[TI Glossary](#) This glossary lists and explains terms, acronyms, and definitions.

10 Revision History

NOTE: Page numbers for previous revisions may differ from page numbers in the current version.

Changes from Revision G (September 2016) to Revision H (January 2026)	Page
• Updated the numbering format for tables, figures, and cross-references throughout the document	1
• Changed the name of the <i>Available Options</i> section to <i>Device Comparison</i>	3
• Remove "at \overline{MR} " and included \overline{MR} in the pin column.....	4

Changes from Revision F (November 2015) to Revision G (September 2016)	Page
• Changed Package Temperature Range Features bullet to extend to 125°C	1
• Changed supply voltage and temperature range in last paragraph of <i>Description</i> section	1
• Changed maximum specifications in <i>Supply voltage</i> , <i>All other pins</i> , and <i>Operating temperature</i> parameters in <i>Absolute Maximum Ratings</i> table.....	4
• Changed maximum specifications in V_{DD} , PFI, and T_J parameters of <i>Recommended Operating Conditions</i> table.....	4
• Added $T_A = -40^\circ\text{C}$ to 125°C rows to V_{IT-} parameter of <i>Electrical Characteristics</i> table.....	5
• Added second row to $V_{IT-(S)}$ parameter of <i>Electrical Characteristics</i> table.....	5
• Changed I_{DD} parameter of <i>Electrical Characteristics</i> table.....	5
• Changed Typical Characteristics curves <i>TPS3110E09 Supply Current vs Supply Voltage</i> , <i>TPS3110E09 Low-Level Output Voltage vs Low-Level Output Current</i> , <i>TPS3110E09 Low-Level Output Voltage vs Low-Level Output Current</i> , <i>TPS3110E09 High-Level Output Voltage vs High-Level Output Current</i> , and <i>TPS3110K33 High-Level Output Voltage vs High-Level Output Current</i>	10
• Changed <i>Normalized Threshold Voltage vs Free-Air Temperature</i> curve.....	10
• Changed supply voltage range in first sentence of <i>Overview</i> section	12
• Changed supply voltage range in description of <i>Application Information</i> section	17
• Changed <i>Normalized Threshold Voltage vs Free-Air Temperature</i> figure.....	18
• Changed supply voltage range in first sentence of <i>Power Supply Recommendations</i> section.....	19

Changes from Revision E (September 2007) to Revision F (November 2015)	Page
• Added <i>ESD Ratings</i> table, <i>Feature Description</i> section, <i>Device Functional Modes</i> , <i>Application and Implementation</i> section, <i>Power Supply Recommendations</i> section, <i>Layout</i> section, <i>Device and Documentation Support</i> section, and <i>Mechanical, Packaging, and Orderable Information</i> section	1
• Changed title of document	1
• Deleted <i>Features</i> bullet for SOT23-6 package	1
• Changed front-page figure.....	1
• Changed second paragraph of <i>Description</i> section	1
• Changed fourth paragraph of <i>Description</i> section.....	1
• Changed <i>Pin Configuration and Functions</i> section; updated table format	3
• Changed "free-air temperature" to "junction temperature" in <i>Absolute Maximum Ratings</i> condition statement.....	4
• Deleted <i>clamp current</i> from <i>Absolute Maximum Ratings</i> table; changed to <i>current</i>	4
• Deleted soldering temperature specification from <i>Absolute Maximum Ratings</i> table.....	4
• Changed "free-air temperature" to "junction temperature" in <i>Recommended Operating Conditions</i> condition statement	4
• Added <i>Thermal Information</i> table; deleted <i>Dissipation Ratings</i> table.....	5
• Changed "free-air temperature" to "junction temperature" in <i>Electrical Characteristics</i> condition statement	5
• Changed <i>Switching Characteristics</i> table.....	7
• Changed Figure 6-1 title and timing drawing	7
• Changed Figure 6-2 title.....	7
• Changed Figure 6-3	7

-
- Changed [Figure 6-4](#)7
-

11 Mechanical, Packaging, and Orderable Information

The following pages include mechanical, packaging, and orderable information. This information is the most current data available for the designated devices. This data is subject to change without notice and revision of this document. For browser-based versions of this data sheet, refer to the left-hand navigation.

PACKAGING INFORMATION

Orderable part number	Status (1)	Material type (2)	Package Pins	Package qty Carrier	RoHS (3)	Lead finish/ Ball material (4)	MSL rating/ Peak reflow (5)	Op temp (°C)	Part marking (6)
TPS3103E12DBVR	Active	Production	SOT-23 (DBV) 6	3000 LARGE T&R	Yes	NIPDAU	Level-1-260C-UNLIM	-40 to 125	PFWI
TPS3103E12DBVR.B	Active	Production	SOT-23 (DBV) 6	3000 LARGE T&R	Yes	NIPDAU	Level-1-260C-UNLIM	-40 to 125	PFWI
TPS3103E12DBVRG4	Active	Production	SOT-23 (DBV) 6	3000 LARGE T&R	Yes	NIPDAU	Level-1-260C-UNLIM	-40 to 125	PFWI
TPS3103E12DBVRG4.B	Active	Production	SOT-23 (DBV) 6	3000 LARGE T&R	Yes	NIPDAU	Level-1-260C-UNLIM	-40 to 125	PFWI
TPS3103E12DBVT	Active	Production	SOT-23 (DBV) 6	250 SMALL T&R	Yes	NIPDAU	Level-1-260C-UNLIM	-40 to 125	PFWI
TPS3103E12DBVT.B	Active	Production	SOT-23 (DBV) 6	250 SMALL T&R	Yes	NIPDAU	Level-1-260C-UNLIM	-40 to 125	PFWI
TPS3103E15DBVR	Active	Production	SOT-23 (DBV) 6	3000 LARGE T&R	Yes	NIPDAU	Level-1-260C-UNLIM	-40 to 125	PFXI
TPS3103E15DBVR.B	Active	Production	SOT-23 (DBV) 6	3000 LARGE T&R	Yes	NIPDAU	Level-1-260C-UNLIM	-40 to 125	PFXI
TPS3103E15DBVRG4	Active	Production	SOT-23 (DBV) 6	3000 LARGE T&R	Yes	NIPDAU	Level-1-260C-UNLIM	-40 to 125	PFXI
TPS3103E15DBVRG4.B	Active	Production	SOT-23 (DBV) 6	3000 LARGE T&R	Yes	NIPDAU	Level-1-260C-UNLIM	-40 to 125	PFXI
TPS3103E15DBVT	Active	Production	SOT-23 (DBV) 6	250 SMALL T&R	Yes	NIPDAU	Level-1-260C-UNLIM	-40 to 125	PFXI
TPS3103E15DBVT.B	Active	Production	SOT-23 (DBV) 6	250 SMALL T&R	Yes	NIPDAU	Level-1-260C-UNLIM	-40 to 125	PFXI
TPS3103H20DBVR	Active	Production	SOT-23 (DBV) 6	3000 LARGE T&R	Yes	NIPDAU	Level-1-260C-UNLIM	-40 to 125	PFYI
TPS3103H20DBVR.B	Active	Production	SOT-23 (DBV) 6	3000 LARGE T&R	Yes	NIPDAU	Level-1-260C-UNLIM	-40 to 125	PFYI
TPS3103H20DBVRG4	Active	Production	SOT-23 (DBV) 6	3000 LARGE T&R	Yes	NIPDAU	Level-1-260C-UNLIM	-40 to 125	PFYI
TPS3103H20DBVRG4.B	Active	Production	SOT-23 (DBV) 6	3000 LARGE T&R	Yes	NIPDAU	Level-1-260C-UNLIM	-40 to 125	PFYI
TPS3103H20DBVT	Active	Production	SOT-23 (DBV) 6	250 SMALL T&R	Yes	NIPDAU	Level-1-260C-UNLIM	-40 to 125	PFYI
TPS3103H20DBVT.B	Active	Production	SOT-23 (DBV) 6	250 SMALL T&R	Yes	NIPDAU	Level-1-260C-UNLIM	-40 to 125	PFYI
TPS3103K33DBVR	Active	Production	SOT-23 (DBV) 6	3000 LARGE T&R	Yes	NIPDAU	Level-1-260C-UNLIM	-40 to 125	PGRI
TPS3103K33DBVR.B	Active	Production	SOT-23 (DBV) 6	3000 LARGE T&R	Yes	NIPDAU	Level-1-260C-UNLIM	-40 to 125	PGRI
TPS3103K33DBVR1G4	Active	Production	SOT-23 (DBV) 6	3000 LARGE T&R	Yes	NIPDAU	Level-1-260C-UNLIM	-40 to 125	PGRI
TPS3103K33DBVR1G4.B	Active	Production	SOT-23 (DBV) 6	3000 LARGE T&R	Yes	NIPDAU	Level-1-260C-UNLIM	-40 to 125	PGRI
TPS3103K33DBVT	Active	Production	SOT-23 (DBV) 6	250 SMALL T&R	Yes	NIPDAU	Level-1-260C-UNLIM	-40 to 125	PGRI
TPS3103K33DBVT.B	Active	Production	SOT-23 (DBV) 6	250 SMALL T&R	Yes	NIPDAU	Level-1-260C-UNLIM	-40 to 125	PGRI
TPS3106E09DBVR	Active	Production	SOT-23 (DBV) 6	3000 LARGE T&R	Yes	NIPDAU	Level-1-260C-UNLIM	-40 to 125	PFZI
TPS3106E09DBVR.B	Active	Production	SOT-23 (DBV) 6	3000 LARGE T&R	Yes	NIPDAU	Level-1-260C-UNLIM	-40 to 125	PFZI
TPS3106E09DBVT	Active	Production	SOT-23 (DBV) 6	250 SMALL T&R	Yes	NIPDAU	Level-1-260C-UNLIM	-40 to 125	PFZI
TPS3106E09DBVT.B	Active	Production	SOT-23 (DBV) 6	250 SMALL T&R	Yes	NIPDAU	Level-1-260C-UNLIM	-40 to 125	PFZI
TPS3106E16DBVR	Active	Production	SOT-23 (DBV) 6	3000 LARGE T&R	Yes	NIPDAU	Level-1-260C-UNLIM	-40 to 125	PGSI

Orderable part number	Status (1)	Material type (2)	Package Pins	Package qty Carrier	RoHS (3)	Lead finish/ Ball material (4)	MSL rating/ Peak reflow (5)	Op temp (°C)	Part marking (6)
TPS3106E16DBVR.B	Active	Production	SOT-23 (DBV) 6	3000 LARGE T&R	Yes	NIPDAU	Level-1-260C-UNLIM	-40 to 125	PGSI
TPS3106E16DBVT	Active	Production	SOT-23 (DBV) 6	250 SMALL T&R	Yes	NIPDAU	Level-1-260C-UNLIM	-40 to 125	PGSI
TPS3106E16DBVT.B	Active	Production	SOT-23 (DBV) 6	250 SMALL T&R	Yes	NIPDAU	Level-1-260C-UNLIM	-40 to 125	PGSI
TPS3106K33DBVR	Active	Production	SOT-23 (DBV) 6	3000 LARGE T&R	Yes	NIPDAU	Level-1-260C-UNLIM	-40 to 125	PGBI
TPS3106K33DBVR.B	Active	Production	SOT-23 (DBV) 6	3000 LARGE T&R	Yes	NIPDAU	Level-1-260C-UNLIM	-40 to 125	PGBI
TPS3106K33DBVR1G4	Active	Production	SOT-23 (DBV) 6	3000 LARGE T&R	Yes	NIPDAU	Level-1-260C-UNLIM	-40 to 125	PGBI
TPS3106K33DBVR1G4.B	Active	Production	SOT-23 (DBV) 6	3000 LARGE T&R	Yes	NIPDAU	Level-1-260C-UNLIM	-40 to 125	PGBI
TPS3106K33DBVT	Active	Production	SOT-23 (DBV) 6	250 SMALL T&R	Yes	NIPDAU	Level-1-260C-UNLIM	-40 to 125	PGBI
TPS3106K33DBVT.B	Active	Production	SOT-23 (DBV) 6	250 SMALL T&R	Yes	NIPDAU	Level-1-260C-UNLIM	-40 to 125	PGBI
TPS3110E09DBVR	Active	Production	SOT-23 (DBV) 6	3000 LARGE T&R	Yes	NIPDAU	Level-1-260C-UNLIM	-40 to 125	PGII
TPS3110E09DBVR.B	Active	Production	SOT-23 (DBV) 6	3000 LARGE T&R	Yes	NIPDAU	Level-1-260C-UNLIM	-40 to 125	PGII
TPS3110E12DBVR	Active	Production	SOT-23 (DBV) 6	3000 LARGE T&R	Yes	NIPDAU	Level-1-260C-UNLIM	-40 to 125	PGJI
TPS3110E12DBVR.B	Active	Production	SOT-23 (DBV) 6	3000 LARGE T&R	Yes	NIPDAU	Level-1-260C-UNLIM	-40 to 125	PGJI
TPS3110E12DBVT	Active	Production	SOT-23 (DBV) 6	250 SMALL T&R	Yes	NIPDAU	Level-1-260C-UNLIM	-40 to 125	PGJI
TPS3110E12DBVT.B	Active	Production	SOT-23 (DBV) 6	250 SMALL T&R	Yes	NIPDAU	Level-1-260C-UNLIM	-40 to 125	PGJI
TPS3110E15DBVR	Active	Production	SOT-23 (DBV) 6	3000 LARGE T&R	Yes	NIPDAU	Level-1-260C-UNLIM	-40 to 125	PGKI
TPS3110E15DBVR.B	Active	Production	SOT-23 (DBV) 6	3000 LARGE T&R	Yes	NIPDAU	Level-1-260C-UNLIM	-40 to 125	PGKI
TPS3110E15DBVT	Active	Production	SOT-23 (DBV) 6	250 SMALL T&R	Yes	NIPDAU	Level-1-260C-UNLIM	-40 to 125	PGKI
TPS3110E15DBVT.B	Active	Production	SOT-23 (DBV) 6	250 SMALL T&R	Yes	NIPDAU	Level-1-260C-UNLIM	-40 to 125	PGKI
TPS3110K33DBVR	Active	Production	SOT-23 (DBV) 6	3000 LARGE T&R	Yes	NIPDAU	Level-1-260C-UNLIM	-40 to 125	PGLI
TPS3110K33DBVR.B	Active	Production	SOT-23 (DBV) 6	3000 LARGE T&R	Yes	NIPDAU	Level-1-260C-UNLIM	-40 to 125	PGLI
TPS3110K33DBVT	Active	Production	SOT-23 (DBV) 6	250 SMALL T&R	Yes	NIPDAU	Level-1-260C-UNLIM	-40 to 125	PGLI
TPS3110K33DBVT.B	Active	Production	SOT-23 (DBV) 6	250 SMALL T&R	Yes	NIPDAU	Level-1-260C-UNLIM	-40 to 125	PGLI

⁽¹⁾ **Status:** For more details on status, see our [product life cycle](#).

⁽²⁾ **Material type:** When designated, preproduction parts are prototypes/experimental devices, and are not yet approved or released for full production. Testing and final process, including without limitation quality assurance, reliability performance testing, and/or process qualification, may not yet be complete, and this item is subject to further changes or possible discontinuation. If available for ordering, purchases will be subject to an additional waiver at checkout, and are intended for early internal evaluation purposes only. These items are sold without warranties of any kind.

⁽³⁾ **RoHS values:** Yes, No, RoHS Exempt. See the [TI RoHS Statement](#) for additional information and value definition.

(4) **Lead finish/Ball material:** Parts may have multiple material finish options. Finish options are separated by a vertical ruled line. Lead finish/Ball material values may wrap to two lines if the finish value exceeds the maximum column width.

(5) **MSL rating/Peak reflow:** The moisture sensitivity level ratings and peak solder (reflow) temperatures. In the event that a part has multiple moisture sensitivity ratings, only the lowest level per JEDEC standards is shown. Refer to the shipping label for the actual reflow temperature that will be used to mount the part to the printed circuit board.

(6) **Part marking:** There may be an additional marking, which relates to the logo, the lot trace code information, or the environmental category of the part.

Multiple part markings will be inside parentheses. Only one part marking contained in parentheses and separated by a "~" will appear on a part. If a line is indented then it is a continuation of the previous line and the two combined represent the entire part marking for that device.

Important Information and Disclaimer: The information provided on this page represents TI's knowledge and belief as of the date that it is provided. TI bases its knowledge and belief on information provided by third parties, and makes no representation or warranty as to the accuracy of such information. Efforts are underway to better integrate information from third parties. TI has taken and continues to take reasonable steps to provide representative and accurate information but may not have conducted destructive testing or chemical analysis on incoming materials and chemicals. TI and TI suppliers consider certain information to be proprietary, and thus CAS numbers and other limited information may not be available for release.

In no event shall TI's liability arising out of such information exceed the total purchase price of the TI part(s) at issue in this document sold by TI to Customer on an annual basis.

OTHER QUALIFIED VERSIONS OF TPS3106 :

- Enhanced Product : [TPS3106-EP](#)

NOTE: Qualified Version Definitions:

- Enhanced Product - Supports Defense, Aerospace and Medical Applications

TAPE AND REEL INFORMATION

QUADRANT ASSIGNMENTS FOR PIN 1 ORIENTATION IN TAPE

*All dimensions are nominal

Device	Package Type	Package Drawing	Pins	SPQ	Reel Diameter (mm)	Reel Width W1 (mm)	A0 (mm)	B0 (mm)	K0 (mm)	P1 (mm)	W (mm)	Pin1 Quadrant
TPS3103E12DBVR	SOT-23	DBV	6	3000	178.0	9.0	3.23	3.17	1.37	4.0	8.0	Q3
TPS3103E12DBVRG4	SOT-23	DBV	6	3000	178.0	9.0	3.23	3.17	1.37	4.0	8.0	Q3
TPS3103E12DBVRG4	SOT-23	DBV	6	3000	179.0	8.4	3.2	3.2	1.4	4.0	8.0	Q3
TPS3103E12DBVT	SOT-23	DBV	6	250	178.0	9.0	3.23	3.17	1.37	4.0	8.0	Q3
TPS3103E12DBVT	SOT-23	DBV	6	250	179.0	8.4	3.2	3.2	1.4	4.0	8.0	Q3
TPS3103E15DBVR	SOT-23	DBV	6	3000	179.0	8.4	3.2	3.2	1.4	4.0	8.0	Q3
TPS3103E15DBVRG4	SOT-23	DBV	6	3000	179.0	8.4	3.2	3.2	1.4	4.0	8.0	Q3
TPS3103E15DBVT	SOT-23	DBV	6	250	179.0	8.4	3.2	3.2	1.4	4.0	8.0	Q3
TPS3103H20DBVR	SOT-23	DBV	6	3000	179.0	8.4	3.2	3.2	1.4	4.0	8.0	Q3
TPS3103H20DBVR	SOT-23	DBV	6	3000	178.0	9.0	3.23	3.17	1.37	4.0	8.0	Q3
TPS3103H20DBVRG4	SOT-23	DBV	6	3000	178.0	9.0	3.23	3.17	1.37	4.0	8.0	Q3
TPS3103H20DBVRG4	SOT-23	DBV	6	3000	179.0	8.4	3.2	3.2	1.4	4.0	8.0	Q3
TPS3103H20DBVT	SOT-23	DBV	6	250	179.0	8.4	3.2	3.2	1.4	4.0	8.0	Q3
TPS3103H20DBVT	SOT-23	DBV	6	250	178.0	9.0	3.23	3.17	1.37	4.0	8.0	Q3
TPS3103K33DBVR	SOT-23	DBV	6	3000	179.0	8.4	3.2	3.2	1.4	4.0	8.0	Q3
TPS3103K33DBVR1G4	SOT-23	DBV	6	3000	179.0	8.4	3.2	3.2	1.4	4.0	8.0	Q3

Device	Package Type	Package Drawing	Pins	SPQ	Reel Diameter (mm)	Reel Width W1 (mm)	A0 (mm)	B0 (mm)	K0 (mm)	P1 (mm)	W (mm)	Pin1 Quadrant
TPS3103K33DBVT	SOT-23	DBV	6	250	179.0	8.4	3.2	3.2	1.4	4.0	8.0	Q3
TPS3106E09DBVR	SOT-23	DBV	6	3000	180.0	9.0	3.15	3.2	1.4	4.0	8.0	Q3
TPS3106E09DBVR	SOT-23	DBV	6	3000	178.0	9.0	3.23	3.17	1.37	4.0	8.0	Q3
TPS3106E09DBVT	SOT-23	DBV	6	250	180.0	9.0	3.15	3.2	1.4	4.0	8.0	Q3
TPS3106E16DBVR	SOT-23	DBV	6	3000	178.0	9.0	3.23	3.17	1.37	4.0	8.0	Q3
TPS3106E16DBVR	SOT-23	DBV	6	3000	180.0	9.0	3.15	3.2	1.4	4.0	8.0	Q3
TPS3106E16DBVT	SOT-23	DBV	6	250	180.0	9.0	3.15	3.2	1.4	4.0	8.0	Q3
TPS3106E16DBVT	SOT-23	DBV	6	250	178.0	9.0	3.23	3.17	1.37	4.0	8.0	Q3
TPS3106K33DBVR	SOT-23	DBV	6	3000	178.0	9.0	3.23	3.17	1.37	4.0	8.0	Q3
TPS3106K33DBVR1G4	SOT-23	DBV	6	3000	178.0	9.0	3.23	3.17	1.37	4.0	8.0	Q3
TPS3106K33DBVT	SOT-23	DBV	6	250	178.0	9.0	3.23	3.17	1.37	4.0	8.0	Q3
TPS3110E09DBVR	SOT-23	DBV	6	3000	180.0	9.0	3.15	3.2	1.4	4.0	8.0	Q3
TPS3110E12DBVR	SOT-23	DBV	6	3000	178.0	9.0	3.23	3.17	1.37	4.0	8.0	Q3
TPS3110E12DBVR	SOT-23	DBV	6	3000	180.0	9.0	3.15	3.2	1.4	4.0	8.0	Q3
TPS3110E12DBVT	SOT-23	DBV	6	250	180.0	9.0	3.15	3.2	1.4	4.0	8.0	Q3
TPS3110E15DBVR	SOT-23	DBV	6	3000	178.0	9.0	3.23	3.17	1.37	4.0	8.0	Q3
TPS3110E15DBVR	SOT-23	DBV	6	3000	180.0	9.0	3.15	3.2	1.4	4.0	8.0	Q3
TPS3110E15DBVT	SOT-23	DBV	6	250	180.0	9.0	3.15	3.2	1.4	4.0	8.0	Q3
TPS3110E15DBVT	SOT-23	DBV	6	250	178.0	9.0	3.23	3.17	1.37	4.0	8.0	Q3
TPS3110K33DBVR	SOT-23	DBV	6	3000	178.0	9.0	3.23	3.17	1.37	4.0	8.0	Q3
TPS3110K33DBVT	SOT-23	DBV	6	250	180.0	9.0	3.15	3.2	1.4	4.0	8.0	Q3

TAPE AND REEL BOX DIMENSIONS

*All dimensions are nominal

Device	Package Type	Package Drawing	Pins	SPQ	Length (mm)	Width (mm)	Height (mm)
TPS3103E12DBVR	SOT-23	DBV	6	3000	180.0	180.0	18.0
TPS3103E12DBVRG4	SOT-23	DBV	6	3000	180.0	180.0	18.0
TPS3103E12DBVRG4	SOT-23	DBV	6	3000	200.0	183.0	25.0
TPS3103E12DBVT	SOT-23	DBV	6	250	180.0	180.0	18.0
TPS3103E12DBVT	SOT-23	DBV	6	250	200.0	183.0	25.0
TPS3103E15DBVR	SOT-23	DBV	6	3000	200.0	183.0	25.0
TPS3103E15DBVRG4	SOT-23	DBV	6	3000	200.0	183.0	25.0
TPS3103E15DBVT	SOT-23	DBV	6	250	200.0	183.0	25.0
TPS3103H20DBVR	SOT-23	DBV	6	3000	203.0	203.0	35.0
TPS3103H20DBVR	SOT-23	DBV	6	3000	180.0	180.0	18.0
TPS3103H20DBVRG4	SOT-23	DBV	6	3000	180.0	180.0	18.0
TPS3103H20DBVRG4	SOT-23	DBV	6	3000	203.0	203.0	35.0
TPS3103H20DBVT	SOT-23	DBV	6	250	200.0	183.0	25.0
TPS3103H20DBVT	SOT-23	DBV	6	250	180.0	180.0	18.0
TPS3103K33DBVR	SOT-23	DBV	6	3000	200.0	183.0	25.0
TPS3103K33DBVR1G4	SOT-23	DBV	6	3000	200.0	183.0	25.0
TPS3103K33DBVT	SOT-23	DBV	6	250	200.0	183.0	25.0
TPS3106E09DBVR	SOT-23	DBV	6	3000	182.0	182.0	20.0

Device	Package Type	Package Drawing	Pins	SPQ	Length (mm)	Width (mm)	Height (mm)
TPS3106E09DBVR	SOT-23	DBV	6	3000	180.0	180.0	18.0
TPS3106E09DBVT	SOT-23	DBV	6	250	182.0	182.0	20.0
TPS3106E16DBVR	SOT-23	DBV	6	3000	180.0	180.0	18.0
TPS3106E16DBVR	SOT-23	DBV	6	3000	182.0	182.0	20.0
TPS3106E16DBVT	SOT-23	DBV	6	250	182.0	182.0	20.0
TPS3106E16DBVT	SOT-23	DBV	6	250	180.0	180.0	18.0
TPS3106K33DBVR	SOT-23	DBV	6	3000	180.0	180.0	18.0
TPS3106K33DBVR1G4	SOT-23	DBV	6	3000	180.0	180.0	18.0
TPS3106K33DBVT	SOT-23	DBV	6	250	180.0	180.0	18.0
TPS3110E09DBVR	SOT-23	DBV	6	3000	182.0	182.0	20.0
TPS3110E12DBVR	SOT-23	DBV	6	3000	180.0	180.0	18.0
TPS3110E12DBVR	SOT-23	DBV	6	3000	182.0	182.0	20.0
TPS3110E12DBVT	SOT-23	DBV	6	250	182.0	182.0	20.0
TPS3110E15DBVR	SOT-23	DBV	6	3000	180.0	180.0	18.0
TPS3110E15DBVR	SOT-23	DBV	6	3000	182.0	182.0	20.0
TPS3110E15DBVT	SOT-23	DBV	6	250	182.0	182.0	20.0
TPS3110E15DBVT	SOT-23	DBV	6	250	180.0	180.0	18.0
TPS3110K33DBVR	SOT-23	DBV	6	3000	180.0	180.0	18.0
TPS3110K33DBVT	SOT-23	DBV	6	250	182.0	182.0	20.0



DBV0006A

PACKAGE OUTLINE

SOT-23 - 1.45 mm max height

SMALL OUTLINE TRANSISTOR



4214840/G 08/2024

NOTES:

1. All linear dimensions are in millimeters. Any dimensions in parenthesis are for reference only. Dimensioning and tolerancing per ASME Y14.5M.
2. This drawing is subject to change without notice.
3. Body dimensions do not include mold flash or protrusion. Mold flash and protrusion shall not exceed 0.25 per side.
4. Leads 1,2,3 may be wider than leads 4,5,6 for package orientation.
5. Reference JEDEC MO-178.

EXAMPLE BOARD LAYOUT

DBV0006A

SOT-23 - 1.45 mm max height

SMALL OUTLINE TRANSISTOR



LAND PATTERN EXAMPLE
EXPOSED METAL SHOWN
SCALE:15X



SOLDER MASK DETAILS

4214840/G 08/2024

NOTES: (continued)

- 6. Publication IPC-7351 may have alternate designs.
- 7. Solder mask tolerances between and around signal pads can vary based on board fabrication site.

EXAMPLE STENCIL DESIGN

DBV0006A

SOT-23 - 1.45 mm max height

SMALL OUTLINE TRANSISTOR



SOLDER PASTE EXAMPLE
BASED ON 0.125 mm THICK STENCIL
SCALE:15X

4214840/G 08/2024

NOTES: (continued)

8. Laser cutting apertures with trapezoidal walls and rounded corners may offer better paste release. IPC-7525 may have alternate design recommendations.
9. Board assembly site may have different recommendations for stencil design.

IMPORTANT NOTICE AND DISCLAIMER

TI PROVIDES TECHNICAL AND RELIABILITY DATA (INCLUDING DATASHEETS), DESIGN RESOURCES (INCLUDING REFERENCE DESIGNS), APPLICATION OR OTHER DESIGN ADVICE, WEB TOOLS, SAFETY INFORMATION, AND OTHER RESOURCES "AS IS" AND WITH ALL FAULTS, AND DISCLAIMS ALL WARRANTIES, EXPRESS AND IMPLIED, INCLUDING WITHOUT LIMITATION ANY IMPLIED WARRANTIES OF MERCHANTABILITY, FITNESS FOR A PARTICULAR PURPOSE OR NON-INFRINGEMENT OF THIRD PARTY INTELLECTUAL PROPERTY RIGHTS.

These resources are intended for skilled developers designing with TI products. You are solely responsible for (1) selecting the appropriate TI products for your application, (2) designing, validating and testing your application, and (3) ensuring your application meets applicable standards, and any other safety, security, regulatory or other requirements.

These resources are subject to change without notice. TI grants you permission to use these resources only for development of an application that uses the TI products described in the resource. Other reproduction and display of these resources is prohibited. No license is granted to any other TI intellectual property right or to any third party intellectual property right. TI disclaims responsibility for, and you fully indemnify TI and its representatives against any claims, damages, costs, losses, and liabilities arising out of your use of these resources.

TI's products are provided subject to [TI's Terms of Sale](#), [TI's General Quality Guidelines](#), or other applicable terms available either on ti.com or provided in conjunction with such TI products. TI's provision of these resources does not expand or otherwise alter TI's applicable warranties or warranty disclaimers for TI products. Unless TI explicitly designates a product as custom or customer-specified, TI products are standard, catalog, general purpose devices.

TI objects to and rejects any additional or different terms you may propose.

Copyright © 2026, Texas Instruments Incorporated

Last updated 10/2025