

# TPS5430-Q1 Automotive, 3A, Wide-Input-Range Step-Down Converter

## 1 Features

- Qualified for automotive applications
- Wide input voltage range: 5.5V to 36V
- Up to 3A continuous (4A peak) output current
- High efficiency up to 95% enabled by 100mΩ integrated MOSFET switch
- Wide output voltage range: adjustable down to 1.22V with 1.5% initial accuracy
- Internal compensation minimizes external parts count
- Fixed 500kHz switching frequency for small filter size
- Improved line regulation and transient response by input voltage feed forward
- System protected by overcurrent limiting, overvoltage protection, and thermal shutdown
- -40°C to 125°C operating junction temperature range
- Available in small thermally enhanced 8-pin SOIC PowerPAD™ integrated circuit package
- Create a custom regulator design using the TPS5430-Q1 with the [WEBENCH® Power Designer](#)

## 2 Applications

- Car audio power supplies
- High-power LED supplies, battery chargers
- 12V and 24V supplied systems

## 3 Description

The TPS5430-Q1 is a high-output current PWM converter that integrates a low-resistance high side N-channel MOSFET. Included on the substrate with the listed features are a high-performance voltage error amplifier that provides tight voltage regulation accuracy under transient conditions, an undervoltage lockout (UVLO) circuit to prevent start-up until the input voltage reaches 5.5V, an internally set slow-start circuit to limit inrush currents, and a voltage feed-forward circuit to improve the transient response. Using the enable (ENA) pin, shutdown supply current is reduced to 15µA typically. Other features include an active-high enable, overcurrent limiting, overvoltage protection (OVP), and thermal shutdown. To reduce design complexity and external component count, the TPS5430-Q1 feedback loop is internally compensated. The TPS5430-Q1 regulates a wide variety of power sources including 24V buses.

The TPS5430-Q1 device is available in a thermally enhanced, easy-to-use 8-pin SOIC PowerPAD integrated circuit package. TI provides evaluation modules and the WEBENCH software tool to aid in quickly achieving high-performance power supply designs to meet aggressive equipment development cycles.

### Package Information

PART NUMBER	PACKAGE <sup>(1)</sup>	PACKAGE SIZE <sup>(2)</sup>
TPS5430-Q1	DDA (SO PowerPAD, 8)	4.9mm × 3.9mm

- (1) For more information, see [Section 10](#).
- (2) The package size (length × width) is a nominal value and includes pins, where applicable.

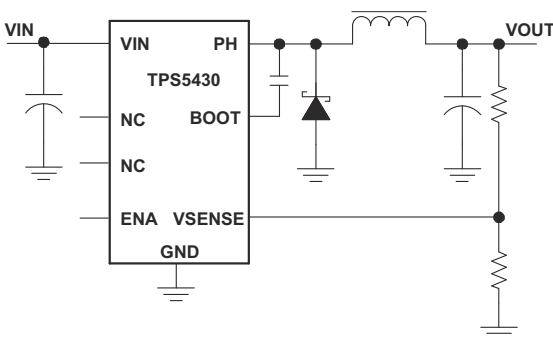

**Simplified Schematic**

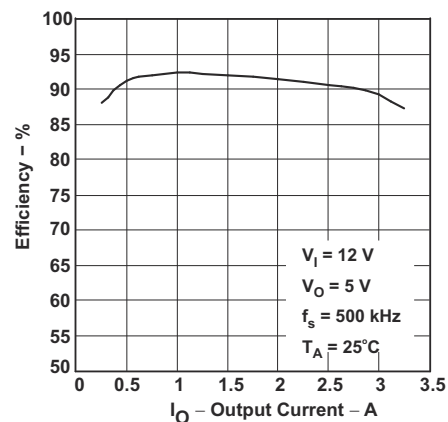

**Efficiency vs Output Current**



## Table of Contents

<b>1 Features</b> .....	<b>1</b>	<b>7 Application and Implementation</b> .....	<b>12</b>
<b>2 Applications</b> .....	<b>1</b>	7.1 Application Information.....	12
<b>3 Description</b> .....	<b>1</b>	7.2 Typical Applications.....	12
<b>4 Pin Configuration and Functions</b> .....	<b>3</b>	7.3 Power Supply Recommendations.....	21
<b>5 Specifications</b> .....	<b>4</b>	7.4 Layout.....	21
5.1 Absolute Maximum Ratings.....	4	<b>8 Device and Documentation Support</b> .....	<b>23</b>
5.2 ESD Ratings.....	4	8.1 Device Support.....	23
5.3 Recommended Operating Conditions.....	4	8.2 Documentation Support.....	23
5.4 Thermal Information (DDA Package).....	4	8.3 Receiving Notification of Documentation Updates....	23
5.5 Electrical Characteristics.....	5	8.4 Support Resources.....	23
5.6 Typical Characteristics.....	6	8.5 Trademarks.....	23
<b>6 Detailed Description</b> .....	<b>8</b>	8.6 Electrostatic Discharge Caution.....	23
6.1 Overview.....	8	8.7 Glossary.....	23
6.2 Functional Block Diagram.....	9	<b>9 Revision History</b> .....	<b>24</b>
6.3 Feature Description.....	9	<b>10 Mechanical, Packaging, and Orderable Information</b> .....	<b>25</b>
6.4 Device Functional Modes.....	11		

## 4 Pin Configuration and Functions

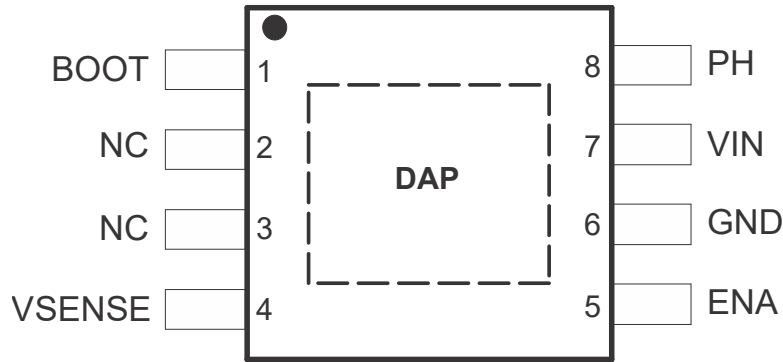

**Figure 4-1. DDA Package 8-Pin SO PowerPAD™ Integrated Circuit Package With Thermal Pad (Top View)**

**Table 4-1. Pin Functions**

PIN		TYPE <sup>(1)</sup>	DESCRIPTION
NO.	NAME		
1	BOOT	O	Boost capacitor for the high-side FET gate driver. Connect 0.01µF low ESR capacitor rated for at least 10V operation from BOOT pin to PH pin.
2, 3	NC	—	No connect, not IO
4	VSENSE	I	Feedback voltage for the regulator. Connect to output voltage divider.
5	ENA	I	On and off control. Below 0.5V, the device stops switching. Above 1.3V, the device starts switching. ENA can be left floating. This pin is internally connected to a 1.5MΩ pullup resistor. Do not connect this pin with a resistor to ground.
6	GND	—	Ground. Connect to DAP.
7	VIN	I	Input supply voltage. Bypass VIN pin to GND pin close to device package with a high quality, low ESR ceramic capacitor. Place the bypass capacitor within 1mm of the Vin pin and within 1mm of the GND pin.
8	PH	O	Source of the high side power MOSFET. Connected to external inductor and diode.
—	DAP	—	GND pin must be connected to the exposed pad for proper operation.

(1) I = input, O = output

## 5 Specifications

### 5.1 Absolute Maximum Ratings

Over operating junction temperature range (unless otherwise noted) <sup>(1)</sup>

		MIN	MAX	UNIT
Input voltage	VIN <sup>(2)</sup> to GND	-0.3	40	V
Input voltage	ENA to GND	-0.3	7	V
Input voltage	VSENSE to GND	-0.3	3	V
Output voltage	BOOT to PH <sup>(3)</sup>	-0.3	6	V
Output voltage	BOOT to GND	-0.3		V
Output voltage	PH to GND, (Steady-state) <sup>(2)</sup>	-0.6	40	V
Output voltage	PH to GND, (transient < 10ns)	-1.2		V
Source current	PH	Internally Limited		
Source current	PH Leakage current		10	μA
T <sub>J</sub>	Operating virtual junction temperature	-40	150	°C
T <sub>stg</sub>	Storage temperature	-65	150	°C

- (1) Operation outside the Absolute Maximum Ratings may cause permanent device damage. Absolute Maximum Ratings do not imply functional operation of the device at these or any other conditions beyond those listed under [Recommended Operating Conditions](#). If used outside the Recommended Operating Conditions but within the Absolute Maximum Ratings, the device may not be fully functional, and this may affect device reliability, functionality, performance, and shorten the device lifetime.
- (2) Approaching the absolute maximum rating for the VIN pin can cause the voltage on the PH pin to exceed the absolute maximum rating.
- (3) BOOT to PH Abs MAX voltage is the maximum voltage that can be applied between BOOT and PH. Some devices develop voltage above 6V but below 10V during operation. These devices are not damaged by this voltage. Because some devices develop voltage above 6V during operation, capacitors placed between BOOT and PH must be rated for at least 10V operation.

### 5.2 ESD Ratings

			VALUE	UNIT
V <sub>(ESD)</sub>	Electrostatic discharge	Human body model (HBM), per AEC Q100-002 HBM ESD Classification Level 2 <sup>(1)</sup>	±2000	V
		Charged device model (CDM), per AEC Q100-011 CDM ESD Classification Level C5	±750	

- (1) AEC Q100-002 indicates that HBM stressing must be in accordance with the ANSI/ESDA/JEDEC JS-001 specification.

### 5.3 Recommended Operating Conditions

Over operating junction temperature range (unless otherwise noted)

		MIN	NOM	MAX	UNIT
Input voltage	Input voltage range	5.5		36	V
T <sub>J</sub>	Operating junction temperature	-40		125	°C

### 5.4 Thermal Information (DDA Package)

THERMAL METRIC <sup>(1)</sup>		TPS5430	UNIT
		DDA (HSOIC)	
		8 PINS	
R <sub>θJA</sub>	Junction-to-ambient thermal resistance (TPS5430EVM) <sup>(2)</sup>	45	°C/W
R <sub>θJA</sub>	Junction-to-ambient thermal resistance (JESD 51-7) <sup>(3)</sup>	42.3	°C/W
R <sub>θJC(top)</sub>	Junction-to-case (top) thermal resistance	46	°C/W
R <sub>θJB</sub>	Junction-to-board thermal resistance	15	°C/W
ψ <sub>JT</sub>	Junction-to-top characterization parameter	5.2	°C/W
ψ <sub>JB</sub>	Junction-to-board characterization parameter	15.3	°C/W

## 5.4 Thermal Information (DDA Package) (continued)

THERMAL METRIC <sup>(1)</sup>		TPS5430		UNIT
		DDA (HSOIC)		
		8 PINS		
R <sub>θJC(bot)</sub>	Junction-to-case (bottom) thermal resistance	6		°C/W

- (1) For more information about traditional and new thermal metrics, see [Semiconductor and IC Package Thermal Metrics application note](#).
- (2) Refer to the [EVM User's Guide](#) for board layout and additional information. For thermal design information please see the Maximum Ambient Temperature section.
- (3) The value of R<sub>θJA</sub> given in this table is only valid for comparison with other packages and cannot be used for design purposes. These values were calculated in accordance with JESD 51-7, and simulated on a 4-layer JEDEC board. These values do not represent the performance obtained in an actual application. For example, the EVM R<sub>θJA</sub> = 45 °C/W. For design information please see the [Maximum Ambient Temperature](#) section.

## 5.5 Electrical Characteristics

T<sub>J</sub> = -40°C to +125°C, V<sub>IN</sub> = 5.5V to 36V. Typical values are at T<sub>J</sub> = 25°C and V<sub>IN</sub> = 12V (unless otherwise noted)

PARAMETER		TEST CONDITIONS	MIN	TYP	MAX	UNIT
<b>SUPPLY VOLTAGE (VIN PIN)</b>						
I <sub>Q(VIN)</sub>	VIN quiescent current	Non-switching, VSENSE = 2V, PH pin open		2	4.4	mA
I <sub>SD(VIN)</sub>	VIN shutdown supply current	Shutdown, ENA = 0V		15	50	µA
<b>UVLO</b>						
V <sub>INUVLO(R)</sub>	VIN UVLO rising threshold	V <sub>VIN</sub> rising		5.3	5.5	V
V <sub>INUVLO(H)</sub>	VIN UVLO hysteresis			0.35		V
<b>VOLTAGE REFERENCE</b>						
V <sub>FB</sub>	FB voltage	T <sub>J</sub> = 25°C	1.202	1.221	1.239	V
V <sub>FB</sub>	FB voltage	T <sub>J</sub> = -40°C to 125°C	1.196	1.221	1.245	V
<b>OSCILLATOR</b>						
f <sub>SW</sub>	Switching frequency		400	500	600	kHz
t <sub>ON(min)</sub>	Minimum ON pulse width			150	200	ns
D <sub>MAX</sub>	Maximum duty cycle	f <sub>SW</sub> = 500kHz	87%	89%		
<b>ENABLE (ENA PIN)</b>						
V <sub>EN(R)</sub>	ENA voltage rising threshold				1.3	V
V <sub>EN(F)</sub>	ENA voltage falling threshold		0.5			V
V <sub>EN(H)</sub>	ENA voltage hysteresis			325		mV
t <sub>SS</sub>	Internal slow-start time (0 to 100%)		5.4	8	10	ms
<b>OVERCURRENT PROTECTION</b>						
I <sub>HS(OC)</sub>	High-side peak current limit		4.0	5.0	7.0	A
	Hiccup time before re-start		13	16	21	ms
<b>OUTPUT MOSFET</b>						
R <sub>DSON(HS)</sub>	High-side MOSFET on-resistance	V <sub>IN</sub> = 12V, V <sub>BOOT-SW</sub> = 4.5V		100	230	mΩ
R <sub>DSON(HS)</sub>	High-side MOSFET on-resistance	V <sub>IN</sub> = 5.5V, V <sub>BOOT-SW</sub> = 4.0V		125		mΩ
<b>THERMAL SHUTDOWN</b>						
T <sub>J(SD)</sub>	Thermal shutdown threshold <sup>(1)</sup>	Temperature rising	135	162		°C
T <sub>J(HYS)</sub>	Thermal shutdown hysteresis <sup>(1)</sup>			14		°C

- (1) Parameter specified by design, statistical analysis and production testing of correlated parameters. Not production tested.

## 5.6 Typical Characteristics

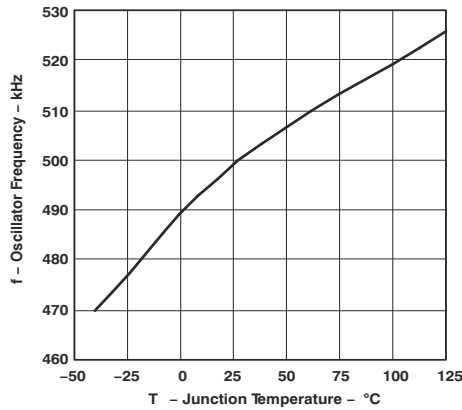

Figure 5-1. Oscillator Frequency vs Junction Temperature

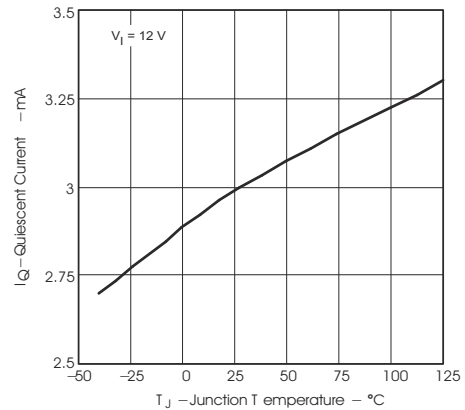

Figure 5-2. Non-Switching Quiescent Current vs Junction Temperature

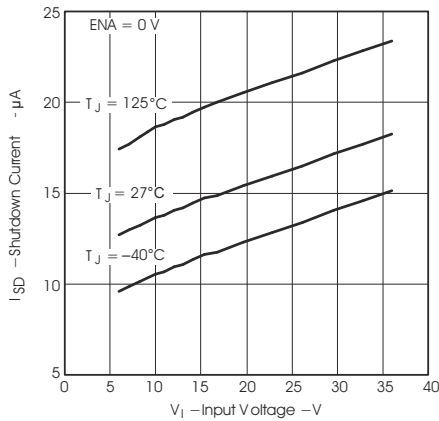

Figure 5-3. Shutdown Quiescent Current vs Input Voltage

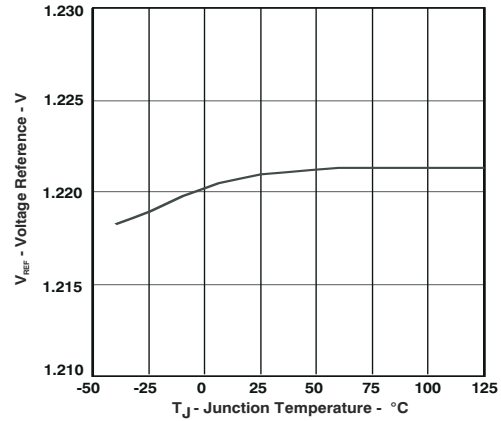

Figure 5-4. Voltage Reference vs Junction Temperature

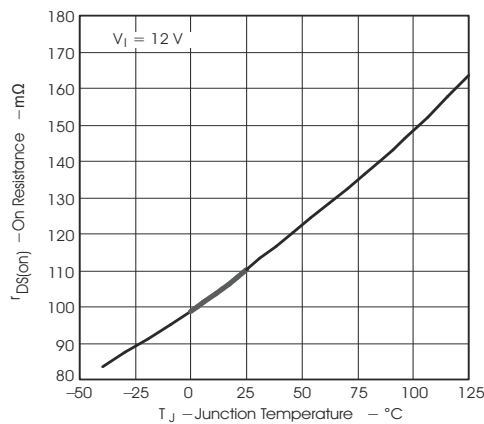

Figure 5-5. ON Resistance vs Junction Temperature

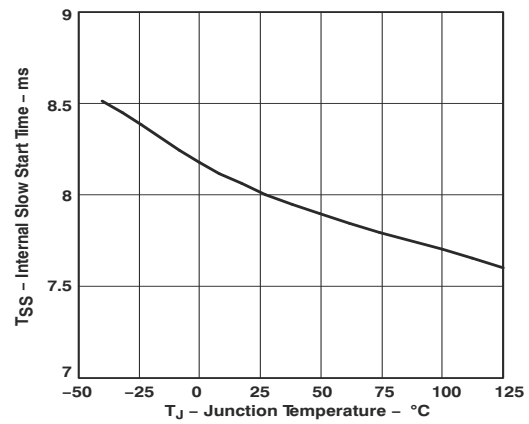
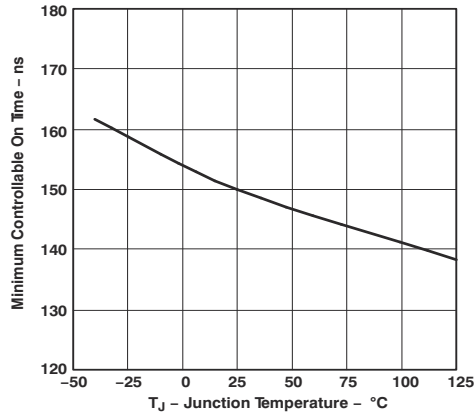
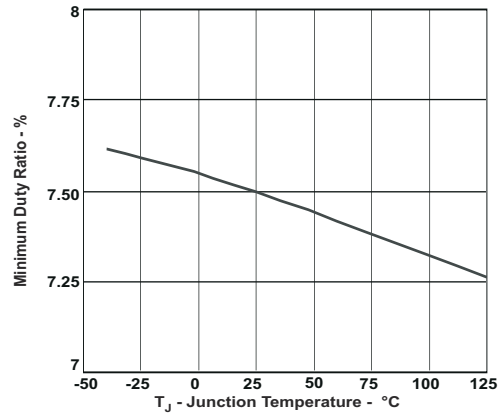

Figure 5-6. Internal Slow Start Time vs Junction Temperature

**5.6 Typical Characteristics (continued)**



**Figure 5-7. Minimum Controllable ON Time vs Junction Temperature**



**Figure 5-8. Minimum Controllable Duty Ratio vs Junction Temperature**

## 6 Detailed Description

### 6.1 Overview

The TPS5430-Q1 is a 3A, step-down (buck) regulator with an integrated high-side n-channel MOSFET. The TPS5430-Q1 is intended to operate from power rails up to 36V. This device implements constant-frequency voltage-mode control with voltage feed forward for improved line regulation and line transient response. Internal compensation reduces design complexity and external component count.

The integrated 100mΩ high-side MOSFET supports high-efficiency power-supply designs capable of delivering 3A of continuous current to a load. The gate-drive bias voltage for the integrated high-side MOSFET is supplied by a bootstrap capacitor connected from the BOOT to PH pins. The device reduces the external component count by integrating the bootstrap recharge diode.

The TPS5430-Q1 has a default input start-up voltage of 5.3V typical. The ENA pin can be used to disable the device, reducing the supply current to 15μA typical. An internal 1.5MΩ pullup resistor enables operation when the ENA pin is floating. The device includes an internal slow-start circuit that slows the output rise time during start-up to reduce inrush current and output voltage overshoot. The minimum output voltage is the internal 1.221V feedback reference. Output overvoltage transients are minimized by an Overvoltage Protection (OVP) comparator. When the OVP comparator is activated, the high-side MOSFET is turned off and remains off until the output voltage is less than 112.5% of the desired output voltage.

Internal cycle-by-cycle overcurrent protection limits the peak current in the integrated high-side MOSFET. For continuous overcurrent fault conditions the device enters hiccup mode overcurrent limiting. Thermal protection protects the device from overheating.

## 6.2 Functional Block Diagram

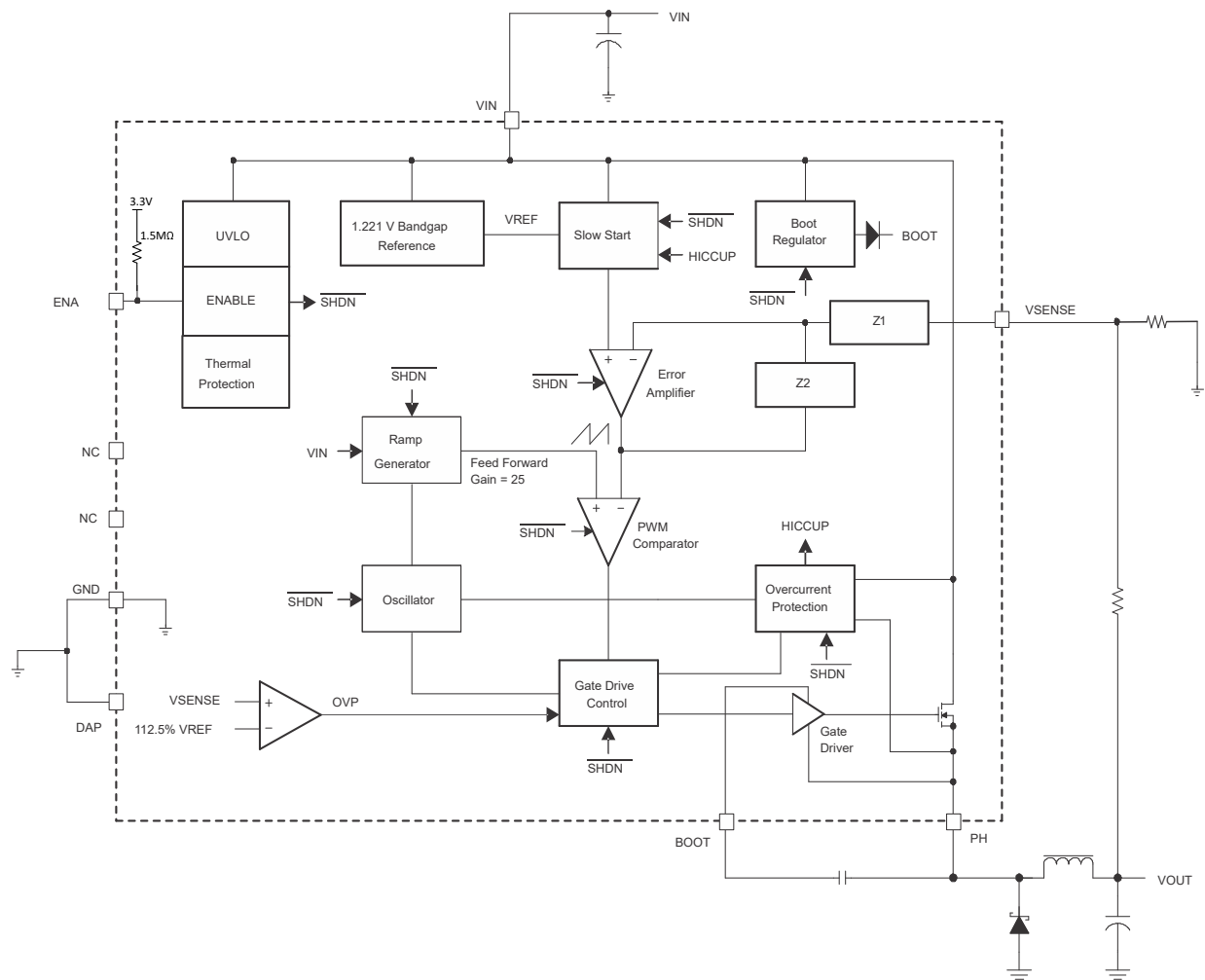

## 6.3 Feature Description

### 6.3.1 Oscillator Frequency

The internal free running oscillator sets the PWM switching frequency at 500kHz. The 500kHz switching frequency allows less output inductance for the same output ripple requirement resulting in a smaller output inductor.

### 6.3.2 Voltage Reference

The voltage reference system produces a precision reference signal by scaling the output of a temperature stable bandgap circuit. The bandgap and scaling circuits are trimmed during production testing to an output of 1.221V at room temperature.

### 6.3.3 Enable (ENA) and Internal Slow Start

The ENA pin provides electrical on and off control of the regulator. After ENA voltage exceeds the threshold voltage, the regulator starts operation and the internal slow start begins to ramp. If ENA voltage is pulled below the threshold voltage, the regulator stops switching and the internal slow start resets. Connecting the pin to ground or to any voltage less than 0.5V disables the regulator and activates the shutdown mode. The quiescent current of the TPS5430-Q1 in shutdown mode is typically 15µA.

ENA has an internal 1.5MΩ pullup resistor, allowing the user to float the ENA pin. If an application requires controlling ENA, use the open-drain or open-collector output logic to interface with the pin. Do not connect a

resistor from this pin to ground. To limit the start-up inrush current, an internal slow-start circuit is used to ramp up the reference voltage from 0V to the final value, linearly. The internal slow start time is 8ms typically.

### 6.3.4 Undervoltage Lockout (UVLO)

The TPS5430-Q1 incorporates a UVLO circuit to keep the device disabled when VIN (the input voltage) is below the UVLO start voltage threshold. During power up, internal circuits are held inactive and the internal slow start is grounded until VIN exceeds the UVLO start threshold voltage. After the UVLO start threshold voltage is reached, the internal slow start is released and device start-up begins. The device operates until VIN falls below the UVLO stop threshold voltage. The typical hysteresis in the UVLO comparator is 350 mV.

### 6.3.5 Boost Capacitor (BOOT)

Connect a 0.01µF low-ESR ceramic capacitor rated for at least 10V operation between the BOOT pin and PH pin. This capacitor provides the gate drive voltage for the high-side MOSFET. TI recommends X7R or X5R grade dielectrics due to the stable values over temperature.

### 6.3.6 Output Feedback (VSENSE) and Internal Compensation

The output voltage of the regulator is set by feeding back the center point voltage of an external resistor divider network to the VSENSE pin. In steady-state operation, VSENSE voltage must be equal to the voltage reference, 1.221V.

The TPS5430-Q1 implements internal compensation to simplify the regulator design. Because the TPS5430-Q1 uses voltage-mode control, a type-3 compensation network has been designed on chip to provide a high crossover frequency and a high phase margin for good stability. See *Internal Compensation Network* in the *Advanced Information* section for more details.

### 6.3.7 Voltage Feed Forward

The internal voltage feed forward provides a constant dc power stage gain despite any variations with the input voltage. This greatly simplifies the stability analysis and improves the transient response. Voltage feed forward varies the peak ramp voltage inversely with the input voltage so that the modulator and power stage gain are constant at the feed forward gain, i.e.,:

$$\text{Feed Forward Gain} = \frac{V_{IN}}{V_{RAMP(pk-pk)}} \quad (1)$$

The typical feed-forward gain of the TPS5430-Q1 is 25.

### 6.3.8 Pulse-Width Modulation (PWM) Control

The regulator employs a fixed-frequency PWM control method. First, the feedback voltage (VSENSE pin voltage) is compared to the constant voltage reference by the high-gain error amplifier and compensation network to produce an error voltage. Then, the error voltage is compared to the ramp voltage by the PWM comparator. In this way, the error voltage magnitude is converted to a pulse width, which is the duty cycle. Finally, the PWM output is fed into the gate-drive circuit to control the on time of the high-side MOSFET.

### 6.3.9 Overcurrent Limiting

Overcurrent limiting is implemented by sensing the drain-to-source voltage across the high-side MOSFET. The drain-to-source voltage is then compared to a voltage level representing the overcurrent threshold limit. If the drain-to-source voltage exceeds the overcurrent threshold limit, the overcurrent indicator is set true. The system ignores the overcurrent indicator for the leading-edge blanking time at the beginning of each cycle to avoid any turn-on noise glitches.

After overcurrent indicator is set true, overcurrent limiting is triggered. The high-side MOSFET is turned off for the rest of the cycle after a propagation delay. The overcurrent limiting mode is called cycle-by-cycle current limiting.

Sometimes under serious overload conditions such as short-circuit, the overcurrent runaway can still happen when using cycle-by-cycle current limiting. A second mode of current limiting is used, i.e., hiccup mode overcurrent limiting. During hiccup mode overcurrent limiting, the voltage reference is grounded and the high-side MOSFET is turned off for the hiccup time. After the hiccup time duration is complete, the regulator restarts under control of the slow-start circuit.

### **6.3.10 Overvoltage Protection (OVP)**

The TPS5430-Q1 has an OVP circuit to minimize voltage overshoot when recovering from output fault conditions. The OVP circuit includes an overvoltage comparator to compare the VSENSE pin voltage and a threshold of  $112.5\% \times VREF$ . After VSENSE voltage is higher than the threshold, the high-side MOSFET is forced off. When VSENSE voltage drops lower than the threshold, the high-side MOSFET is enabled again.

### **6.3.11 Thermal Shutdown**

The TPS5430-Q1 protects from overheating with an internal thermal shutdown circuit. If the junction temperature exceeds the thermal shutdown trip point, the voltage reference is grounded and the high-side MOSFET is turned off. The part is restarted under control of the slow-start circuit automatically when the junction temperature drops 14°C below the thermal shutdown trip point.

## **6.4 Device Functional Modes**

### **6.4.1 Operation near Minimum Input Voltage**

TI recommends the TPS5430-Q1 to operate with input voltages above 5.5V. The typical VIN UVLO threshold is 5.3V and the device can operate at input voltages down to the UVLO voltage. At input voltages below the actual UVLO voltage the device does not switch. If ENA is floating or externally pulled up to greater up than 1.3V, when V(VIN) passes the UVLO threshold the device becomes active. Switching is enabled and the slow-start sequence is initiated. The TPS5430-Q1 starts linearly ramping up the internal reference voltage from 0V to the final value over the internal slow-start time period.

### **6.4.2 Operation With ENA Control**

The enable start threshold voltage is 1.3V (maximum). With ENA held below the 0.5V minimum stop threshold voltage the device is disabled and switching is inhibited even if VIN is above the UVLO threshold. The quiescent current is reduced in this state. If the ENA voltage is increased above the maximum start threshold while V(VIN) is above the UVLO threshold, the device becomes active. Switching is enabled and the slow-start sequence is initiated. The device starts linearly ramping up the internal reference voltage from 0V to the final value over the internal slow-start time period.

## 7 Application and Implementation

### Note

Information in the following applications sections is not part of the TI component specification, and TI does not warrant its accuracy or completeness. TI's customers are responsible for determining suitability of components for their purposes, as well as validating and testing their design implementation to confirm system functionality.

### 7.1 Application Information

The TPS5430-Q1 is a 3A, step down regulator with an integrated high side MOSFET. This device is typically used to convert a higher DC voltage to a lower DC voltage with a maximum available output current of 3A. Example applications are: high density point-of-load regulators for car audio, high-power LED supply, battery chargers, and other 12V and 24V supplied systems. Use the following design procedure to select component values for the TPS5430-Q1.

### 7.2 Typical Applications

#### 7.2.1 Application Circuit, 12V to 5V

Figure 7-1 shows the schematic for a typical TPS5430-Q1 application. The TPS5430-Q1 can provide up to 3A output current at a nominal output voltage of 5V. For proper thermal performance, the exposed thermal pad underneath the device must be soldered down to the printed-circuit-board.

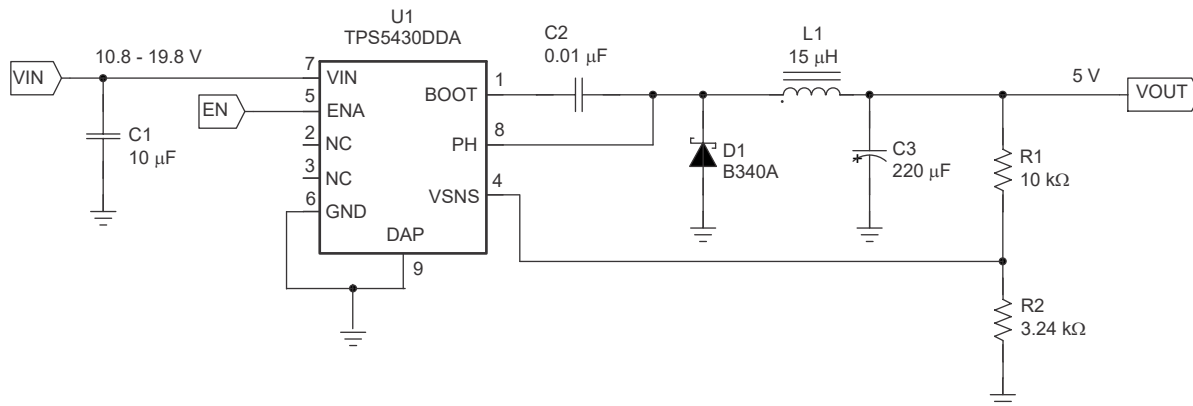

Figure 7-1. Application Circuit, 12V to 5V

#### 7.2.1.1 Design Requirements

For this design example, use the following as the input parameters:

DESIGN PARAMETER <sup>(1)</sup>	EXAMPLE VALUE
Input voltage range	10.8V to 19.8V
Output voltage	5V
Input ripple voltage	300mV
Output ripple voltage	30mV
Output current rating	3A
Operating frequency	500kHz

(1) As an additional constraint, the design is set up to be small size and low component height.

### 7.2.1.2 Detailed Design Procedure

The following design procedure can be used to select component values for the TPS5430-Q1. Alternately, the WEBENCH® Software can be used to generate a complete design. The WEBENCH Software uses an iterative design procedure and accesses a comprehensive database of components when generating a design. This section presents a simplified discussion of the design process.

To begin the design process, a few parameters must be decided upon. The designer needs to know the following:

- Input voltage range
- Output voltage
- Input ripple voltage
- Output ripple voltage
- Output current rating
- Operating frequency

#### 7.2.1.2.1 Custom Design With WEBENCH® Tools

[Click here](#) to create a custom design using the TPS5430-Q1 converter with WEBENCH® Power Designer.

1. Start by entering the input voltage ( $V_{IN}$ ), output voltage ( $V_{OUT}$ ), and output current ( $I_{OUT}$ ) requirements.
2. Optimize the design for key parameters such as efficiency, footprint, and cost using the optimizer dial.
3. Compare the generated design with other possible solutions from Texas Instruments.

The WEBENCH Power Designer provides a customized schematic along with a list of materials with real-time pricing and component availability.

In most cases, these actions are available:

- Run electrical simulations to see important waveforms and circuit performance.
- Run thermal simulations to understand board thermal performance.
- Export customized schematic and layout into popular CAD formats.
- Print PDF reports for the design, and share the design with colleagues.

Get more information about WEBENCH tools at [www.ti.com/WEBENCH](http://www.ti.com/WEBENCH).

#### 7.2.1.2.2 Switching Frequency

The switching frequency for the TPS5430-Q1 is internally set to 500kHz. Adjusting the switching frequency is not possible.

#### 7.2.1.2.3 Input Capacitors

The TPS5430-Q1 requires an input decoupling capacitor and, depending on the application, a bulk input capacitor. The recommended value for the decoupling capacitor, C1, is 10µF. A high-quality ceramic type X5R or X7R is required. For some applications, a smaller-value decoupling capacitor can be used, so long as the input voltage and current ripple ratings are not exceeded. The voltage rating must be greater than the maximum input voltage, including ripple.

This input ripple voltage can be approximated by [Equation 2](#) :

$$\Delta V_{IN} = \frac{I_{OUT(MAX)} \times 0.25}{C_{BULK} \times f_{SW}} + (I_{OUT(MAX)} \times ESR_{MAX}) \quad (2)$$

Where:

$I_{OUT(MAX)}$  is the maximum load current.

$f_{SW}$  is the switching frequency.

$C_{IN}$  is the input capacitor value.

$ESR_{MAX}$  is the maximum series resistance of the input capacitor.

The maximum RMS ripple current also needs to be checked. For worst-case conditions, this can be approximated by [Equation 3](#) :

$$I_{CIN} = \frac{I_{OUT(MAX)}}{2} \quad (3)$$

In this case, the input ripple voltage can be 156mV and the RMS ripple current can be 1.5A. The maximum voltage across the input capacitors can be  $V_{IN}$  maximum plus  $\Delta V_{IN}/2$ . The chosen input decoupling capacitor is rated for 25V and the ripple current capacity is greater than 3A, providing ample margin. Make sure that the maximum ratings for voltage and current are not exceeded under any circumstance.

Additionally some bulk capacitance can be needed, especially if the TPS5430-Q1 circuit is not located within approximately 2 inches from the input voltage source. The value for this capacitor is not critical, but also must be rated to handle the maximum input voltage including ripple voltage and must filter the output so that input ripple voltage is acceptable.

#### 7.2.1.2.4 Output Filter Components

Two components must be selected for the output filter, L1 and C2. Because the TPS5430-Q1 is an internally compensated device, a limited range of filter component types and values can be supported.

##### 7.2.1.2.4.1 Inductor Selection

To calculate the minimum value of the output inductor, use [Equation 4](#):

$$L_{MIN} = \frac{V_{OUT(MAX)} \times (V_{IN(MAX)} - V_{OUT})}{V_{IN(max)} \times K_{IND} \times I_{OUT} \times F_{SW}} \quad (4)$$

$K_{IND}$  is a coefficient that represents the amount of inductor ripple current relative to the maximum output current. Three things need to be considered when determining the amount of ripple current in the inductor: the peak-to-peak ripple current affects the output ripple voltage amplitude, the ripple current affects the peak switch current and the amount of ripple current determines at what point the circuit becomes discontinuous. For designs using the TPS5430-Q1,  $K_{IND}$  of 0.2 to 0.3 yields good results. Low output ripple voltages can be obtained when paired with the proper output capacitor, the peak switch current is well below the current limit set point and relatively low load currents can be sourced before discontinuous operation.

For this design example use  $K_{IND} = 0.2$  and the minimum inductor value is calculated to be 12.5 $\mu$ H. The next highest standard value is 15 $\mu$ H, which is used in this design.

For the output filter inductor, make sure that the RMS current and saturation current ratings not be exceeded. The RMS inductor current can be found from [Equation 5](#):

$$I_{L(RMS)} = \sqrt{I_{OUT(MAX)}^2 + \frac{1}{12} \times \left( \frac{V_{OUT} \times (V_{IN(MAX)} - V_{OUT})}{V_{IN(MAX)} \times L_{OUT} \times F_{SW} \times 0.8} \right)^2} \quad (5)$$

and the peak inductor current can be determined with [Equation 6](#):

$$I_{L(PK)} = I_{OUT(MAX)} + \frac{V_{OUT} \times (V_{IN(MAX)} - V_{OUT})}{1.6 \times V_{IN(MAX)} \times L_{OUT} \times F_{SW}} \quad (6)$$

For this design, the RMS inductor current is 3.003A, and the peak inductor current is 3.31A. The chosen inductor is a Sumida CDRH104R-150 15 $\mu$ H. This inductor has a saturation current rating of 3.4A and a RMS current

rating of 3.6A, easily meeting these requirements. A lesser rated inductor can be used, however this device was chosen because of the low profile component height. In general, inductor values for use with the TPS5430-Q1 are in the range of 10µH to 100µH.

#### 7.2.1.2.4.2 Capacitor Selection

The important design factors for the output capacitor are DC voltage rating, ripple current rating, and equivalent series resistance (ESR). The dc voltage and ripple current ratings cannot be exceeded. The ESR is important because, along with the inductor ripple current, the ESR determines the amount of output ripple voltage. The actual value of the output capacitor is not critical, but some practical limits do exist. Consider the relationship between the desired closed-loop crossover frequency of the design and LC corner frequency of the output filter. Due to the design of the internal compensation, keeping the closed-loop crossover frequency in the range 3kHz to 30kHz is desirable, as this frequency range has adequate phase boost to allow for stable operation. For this design example, assume that the intended closed loop crossover frequency is between 2590Hz and 24kHz and also below the ESR zero of the output capacitor. Under these conditions, the closed-loop crossover frequency is related to the LC corner frequency as:

$$f_{CO} = \frac{f_{LC}^2}{85 V_{OUT}} \quad (7)$$

And the desired output capacitor value for the output filter to:

$$C_{OUT} = \frac{1}{3357 \times L_{OUT} \times f_{CO} \times V_{OUT}} \quad (8)$$

For a desired crossover of 18kHz and a 15µH inductor, the calculated value for the output capacitor is 220µF. The capacitor type must be chosen so that the ESR zero is above the loop crossover. The maximum ESR is:

$$ESR_{MAX} = \frac{1}{2\pi \times C_{OUT} \times f_{CO}} \quad (9)$$

The selected output capacitor must also be rated for a voltage greater than the desired output voltage plus one-half the ripple voltage. Any derating amount must also be included. The maximum RMS ripple current in the output capacitor is given by [Equation 10](#):

$$I_{COUT(RMS)} = \frac{1}{\sqrt{12}} \times \left[ \frac{V_{OUT} \times (V_{IN(MAX)} - V_{OUT})}{V_{IN(MAX)} \times L_{OUT} \times F_{SW} \times N_C} \right] \quad (10)$$

Where:

$N_C$  is the number of output capacitors in parallel.

$F_{SW}$  is the switching frequency.

Other capacitor types can be used with the TPS5430-Q1, depending on the needs of the application.

The maximum ESR of the output capacitor also determines the amount of output ripple as specified in the initial design parameters. The output ripple voltage is the inductor ripple current times the ESR of the output filter. Check that the maximum specified ESR as listed in the capacitor data sheet results in an acceptable output ripple voltage:

$$V_{PP (MAX)} = \frac{ESR_{MAX} \times V_{OUT} \times (V_{IN(MAX)} - V_{OUT})}{N_C \times V_{IN(MAX)} \times L_{OUT} \times F_{SW}} \quad (11)$$

Where:

$\Delta V_{PP}$  is the desired peak-to-peak output ripple.

$N_C$  is the number of parallel output capacitors.

$F_{SW}$  is the switching frequency.

For this design example, a single 220 $\mu$ F output capacitor is chosen for C3. The calculated RMS ripple current is 143mA and the maximum ESR required is 40m $\Omega$ . A capacitor that meets these requirements is a Sanyo Poscap 10TPB220M, rated at 10V with a maximum ESR of 40m $\Omega$  and a ripple current rating of 3A. An additional small 0.1 $\mu$ F ceramic bypass capacitor can also be used, but is not included in this design.

The minimum ESR of the output capacitor must also be considered. For good phase margin, the ESR zero when the ESR is at a minimum must not be too far above the internal compensation poles at 24kHz and 54kHz.

#### 7.2.1.2.5 Output Voltage Setpoint

The output voltage of the TPS5430-Q1 is set by a resistor divider (R1 and R2) from the output to the VSENSE pin. Calculate the R2 resistor value for the output voltage of 5V using [Equation 12](#):

$$R2 = \frac{R1 \times 1.221}{V_{OUT} - 1.221} \quad (12)$$

For any TPS5430-Q1 design, start with an R1 value of 10k $\Omega$ . R2 is then 3.24k $\Omega$  for 5V output.

#### 7.2.1.2.6 Boot Capacitor

The boot capacitor must be 0.01 $\mu$ F rated for at least 10V operation.

#### 7.2.1.2.7 Catch Diode

The TPS5430-Q1 is designed to operate using an external catch diode between PH and GND. The selected diode must meet the absolute maximum ratings for the application: reverse voltage must be higher than the maximum voltage at the PH pin, which is  $V_{IN(MAX)} + 0.5V$ . Peak current must be greater than  $I_{OUT(MAX)}$  plus one-half the peak to peak inductor current. Forward voltage drop must be small for higher efficiencies. Make sure to note that the catch diode conduction time is typically longer than the high-side FET on time, so attention paid to diode parameters can make a marked improvement in overall efficiency. Additionally, check that the device chosen is capable of dissipating the power losses. For this design, a Diodes, Inc. B340A is chosen, with a reverse voltage of 40V, forward current of 3A, and forward voltage drop of 0.5V.

#### 7.2.1.2.8 Advanced Information

##### 7.2.1.2.8.1 Output Voltage Limitations

Due to the internal design of the TPS5430-Q1, there are both upper and lower output voltage limits for any given input voltage. The upper limit of the output voltage set point is constrained by the maximum duty cycle of 87% and is given by:

$$V_{OUTMAX} = 0.87 \times \left( (V_{INMIN} - I_{OMAX} \times 0.230) + V_D \right) - (I_{OMAX} \times R_L) - V_D \quad (13)$$

Where:

$V_{INMIN}$  is the minimum input voltage.

$I_{OMAX}$  is the maximum load current.

$V_D$  is the catch diode forward voltage.

$R_L$  is the output inductor series resistance.

This equation assumes maximum on resistance for the internal high-side FET.

The lower limit is constrained by the minimum controllable on time, which can be as high as 200ns. The approximate minimum output voltage for a given input voltage and minimum load current is given by:

$$V_{OUTMIN} = 0.12 \times \left( (V_{INMAX} - I_{OMIN} \times 0.110) + V_D \right) - (I_{OMIN} \times R_L) - V_D \quad (14)$$

Where:

$V_{INMAX}$  is the maximum input voltage.

$I_{OMIN}$  is the minimum load current.

$V_D$  is the catch diode forward voltage.

$R_L$  is the output inductor series resistance.

This equation assumes nominal on resistance for the high-side FET and accounts for worst-case variation of operating frequency set point. Any design operating near the operational limits of the device must be carefully checked to make sure of proper functionality.

#### 7.2.1.2.8.2 Internal Compensation Network

The design equations given in the example circuit can be used to generate circuits using the TPS5430-Q1. These designs are based on certain assumptions and tend to always select output capacitors within a limited range of ESR values. If a different capacitor type is desired, fitting one to the internal compensation of the TPS5430-Q1 is possible. Equation 15 gives the nominal frequency response of the internal voltage-mode type-3 compensation network:

$$H(s) = \frac{\left(1 + \frac{s}{2\pi \times Fz1}\right) \times \left(1 + \frac{s}{2\pi \times Fz2}\right)}{\left(\frac{s}{2\pi \times Fp0}\right) \times \left(1 + \frac{s}{2\pi \times Fp1}\right) \times \left(1 + \frac{s}{2\pi \times Fp2}\right) \times \left(1 + \frac{s}{2\pi \times Fp3}\right)} \quad (15)$$

Where:

$Fp0 = 2165\text{Hz}$ ,  $Fz1 = 2170\text{Hz}$ ,  $Fz2 = 2590\text{Hz}$

$Fp1 = 24\text{kHz}$ ,  $Fp2 = 54\text{kHz}$ ,  $Fp3 = 440\text{kHz}$

$Fp3$  represents the parasitics effect that is not the best choice.

Using this information along with the desired output voltage, feed-forward gain, and output filter characteristics, the closed-loop transfer function can be derived.

#### 7.2.1.2.8.3 Thermal Calculations

The following formulas show how to estimate the device power dissipation under continuous conduction mode operations. The formulas must not be used if the device is working at light loads in the discontinuous conduction mode.

**Conduction loss:**  $P_{con} = I_{OUT}^2 \times R_{DS(on)} \times V_{OUT}/V_{IN}$  (16)

**Switching loss:**  $P_{sw} = V_{IN} \times I_{OUT} \times 0.01$  (17)

**Quiescent current loss:**  $P_q = V_{IN} \times 0.01$  (18)

**Total loss:**  $P_{tot} = P_{con} + P_{sw} + P_q$  (19)

**Given  $T_A \geq$  Estimated junction temperature:**  $T_J = T_A + R_{th} \times P_{tot}$  (20)

**Given  $T_{JMAX} = 125^\circ\text{C} \geq$  Estimated maximum ambient temperature:**  $T_{AMAX} = T_{JMAX} - R_{th} \times P_{tot}$  (21)

### 7.2.1.3 Application Curves

The performance graphs (Figure 7-2 through Figure 7-8) are applicable to the circuit in Figure 7-1,  $T_A = 25^\circ\text{C}$  (unless otherwise specified).

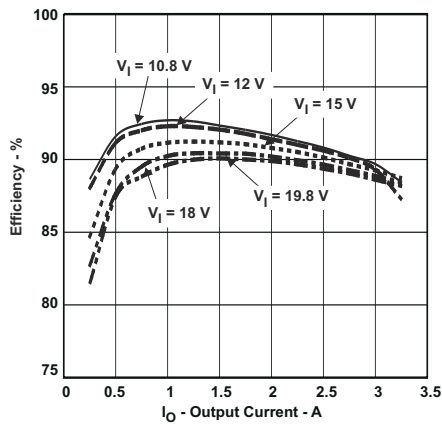

**Figure 7-2. Efficiency vs Output Current**

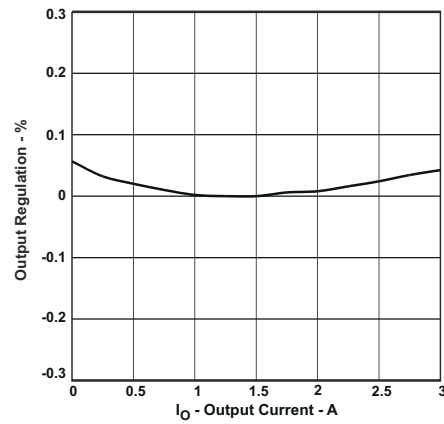

**Figure 7-3. Output Regulation vs Output Current**

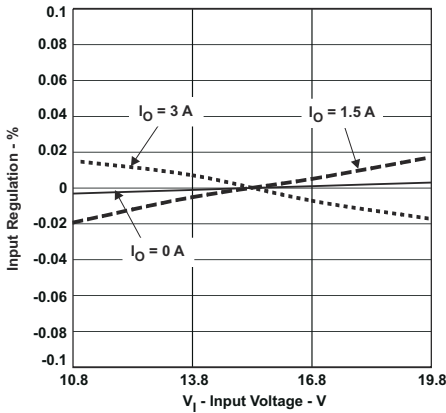

**Figure 7-4. Input Regulation vs Input Voltage**

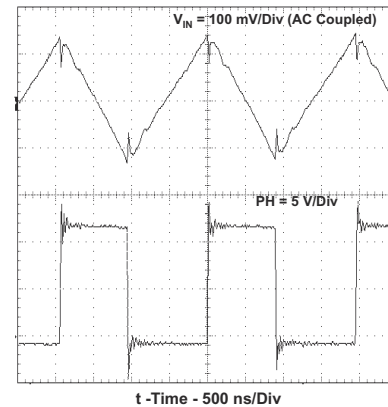

**Figure 7-5. Input Voltage Ripple and PH Node,  $I_O = 3\text{A}$**

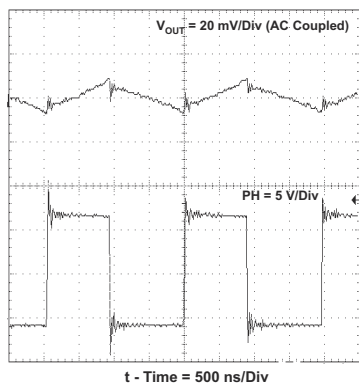

**Figure 7-6. Output Voltage Ripple and PH Node,  $I_O = 3\text{A}$**

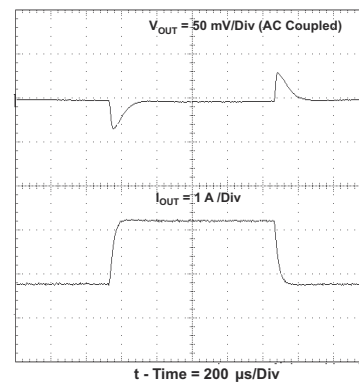

**Figure 7-7. Transient Response,  $I_O$  Step 0.75A to 2.25A**

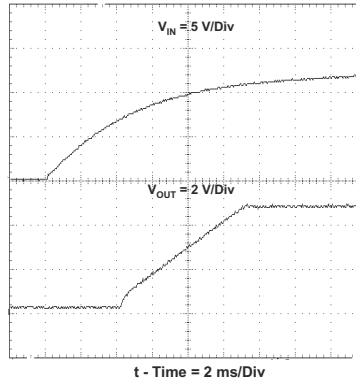

Figure 7-8. Start-Up Waveform,  $V_{IN}$  and  $V_{OUT}$

### 7.2.2 9V to 21V Input to 5V Output Application Circuit

Figure 7-9 and Figure 7-10 show application circuits using wide input voltage ranges. The design parameters are similar to those given for the design example, with a larger value output inductor and a lower closed loop crossover frequency.

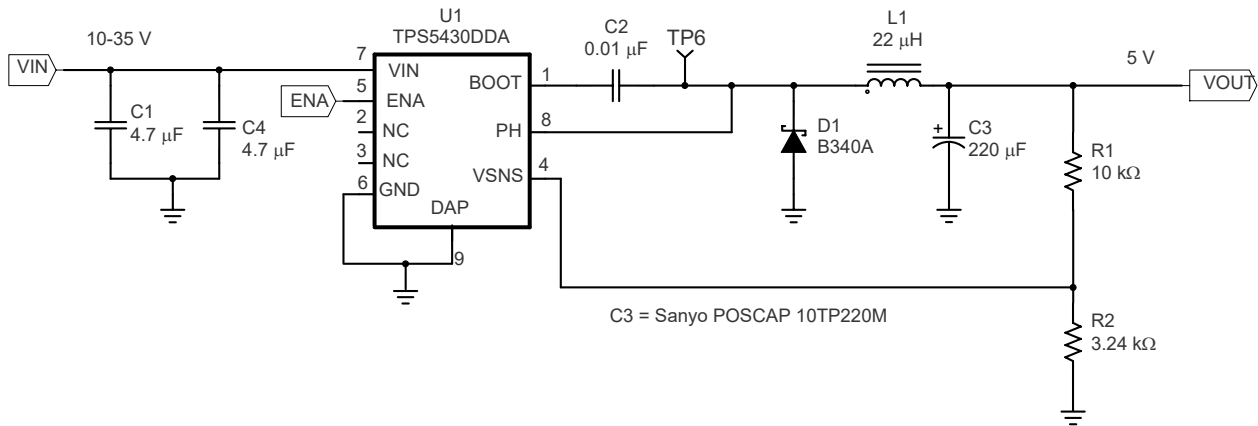

Figure 7-9. 10V to 35V Input to 5V Output Application Circuit

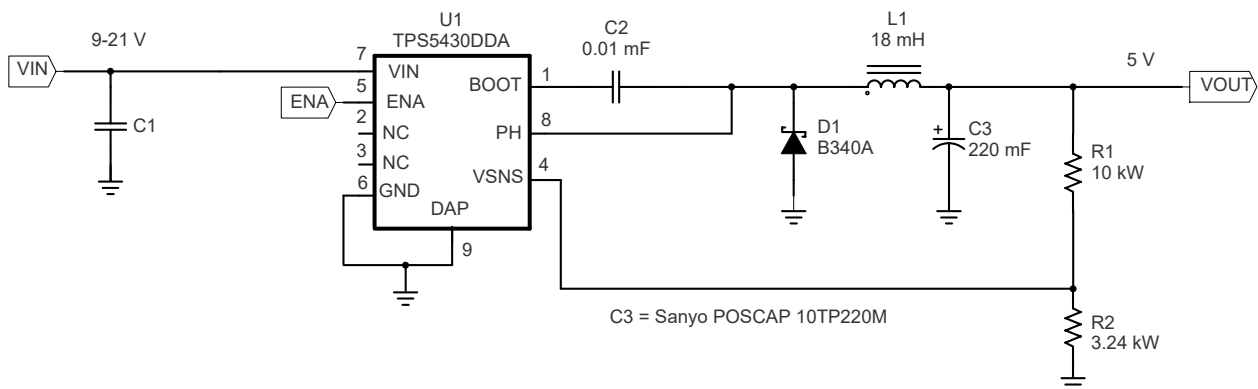

Figure 7-10. 9V to 21V Input to 5V Output Application Circuit

### 7.2.3 Circuit Using Ceramic Output Filter Capacitors

Figure 7-11 shows an application circuit using all ceramic capacitors for the input and output filters, which generates a 3.3V output from a 10V to 24V input. The design procedure is similar to those given for the design example, except for the selection of the output filter capacitor values and the design of the additional compensation components required to stabilize the circuit.

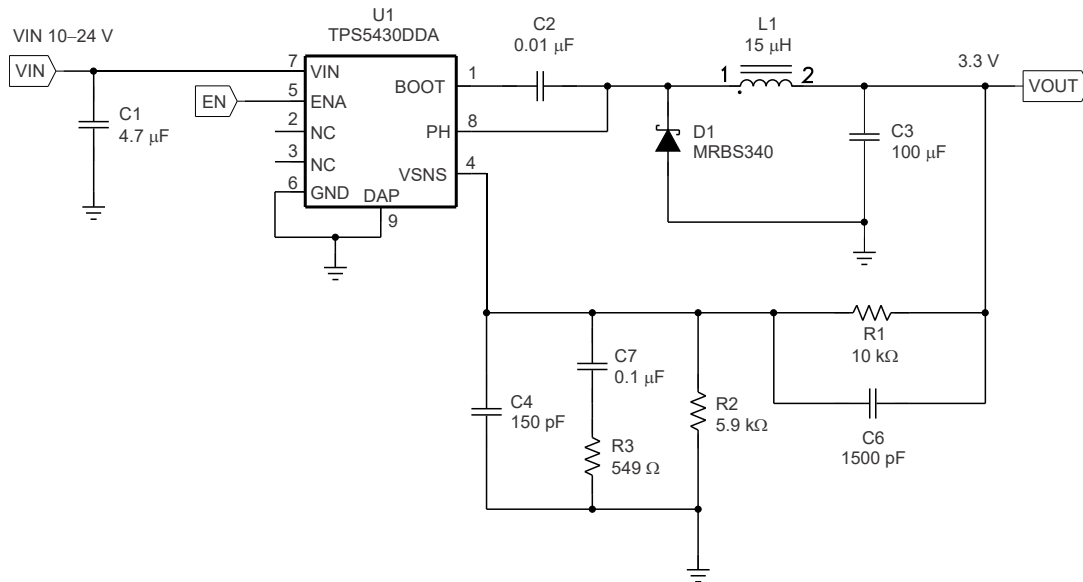

Figure 7-11. Ceramic Output Filter Capacitors Circuit

#### 7.2.3.1 Output Filter Component Selection

Using Equation 10, the minimum inductor value is 12μH. A value of 15μH is chosen for this design.

When using ceramic output filter capacitors, the recommended LC resonant frequency must be no more than 7kHz. Because the output inductor is already selected at 15μH, this selection limits the minimum output capacitor value to:

$$C_O (\text{MIN}) \geq \frac{1}{(2\pi \times 7000)^2 \times L_O} \quad (22)$$

The minimum capacitor value is calculated to be 34μF. For this circuit a larger value of capacitor yields better transient response. A single 100μF output capacitor is used for C3. Make sure to note that the actual capacitance of ceramic capacitors decreases with applied voltage. In this example, the output voltage is set to 3.3V, minimizing this effect.

#### 7.2.3.2 External Compensation Network

When using ceramic output capacitors, additional circuitry is required to stabilize the closed loop system. For this circuit, the external components are R3, C4, C6, and C7. To determine the value of these components, first calculate the LC resonant frequency of the output filter:

$$F_{LC} = \frac{1}{2\pi \sqrt{L_O \times C_O (\text{EFF})}} \quad (23)$$

For this example, the effective resonant frequency is calculated as 4109Hz.

The network composed of R1, R2, R3, C5, C6, and C7 has two poles and two zeros that are used to tailor the overall response of the feedback network to accommodate the use of the ceramic output capacitors. The pole and zero locations are given by the following equations:

$$F_{p1} = 500000 \times \frac{V_O}{F_{LC}} \quad (24)$$

$$F_{z1} = 0.7 \times F_{LC} \quad (25)$$

$$F_{z2} = 2.5 \times F_{LC} \quad (26)$$

The final pole is located at a frequency too high to be of concern. The second zero, Fz2 as defined by [Equation 26](#) uses 2.5 for the frequency multiplier. In some cases this can need to be slightly higher or lower. Values in the range of 2.3 to 2.7 work well. The values for R1 and R2 are fixed by the 3.3V output voltage as calculated using [Equation 12](#). For this design R1 = 10kΩ and R2 = 5.90kΩ. With Fp1 = 401Hz, Fz1 = 2876Hz, and Fz2 = 10.3kHz, the values of R3, C6, and C7 are determined using [Equation 27](#), [Equation 28](#), and [Equation 29](#):

$$C7 = \frac{1}{2\pi \times F_{p1} \times (R1 \parallel R2)} \quad (27)$$

$$R3 = \frac{1}{2\pi \times F_{z1} \times C7} \quad (28)$$

$$C6 = \frac{1}{2\pi \times F_{z2} \times R1} \quad (29)$$

For this design, using the closest standard values, C7 is 0.1μF, R3 is 549Ω, and C6 is 1500pF. C4 is added to improve load regulation performance. It is effectively in parallel with C6 in the location of the second pole frequency, so must be small in relationship to C6. C4 must be less the 1/10 the value of C6. For this example, 150pF works well.

For additional information on external compensation of the wide-voltage-range PWM converter devices, see [Using TPS5410/20/30/31 With Aluminum/Ceramic Output Capacitors](#) application note.

### 7.3 Power Supply Recommendations

The TPS5430-Q1 is designed to operate from an input voltage supply range between 5.5V and 36V. This input supply must remain within the input voltage supply range and the input capacitance for the device must be located near the supply input pin. If the input supply is located more than a few inches from the TPS5430-Q1 converter, bulk capacitance can be required in addition to the ceramic bypass capacitors. An electrolytic capacitor with a value of 100μF is a typical choice.

### 7.4 Layout

#### 7.4.1 Layout Guidelines

Connect a low-ESR ceramic bypass capacitor to the VIN pin. Care must be taken to minimize the loop area formed by the bypass capacitor connections, the VIN pin, and the ground pin. The best way to do this action is to extend the top side ground area from under the device adjacent to the VIN trace, and place the bypass capacitor as close as possible to the VIN pin. The minimum recommended bypass capacitance is 4.7μF ceramic with a X5R or X7R dielectric.

There must be a ground area on the top layer directly underneath the IC, with an exposed area for connection to the thermal pad. Use vias to connect this ground area to any internal ground planes. Use additional vias at the ground side of the input and output filter capacitors as well. The GND pin must be tied to the PCB ground by connecting to the ground area under the device as shown in [Figure 7-12](#).

The PH pin must be routed to the output inductor, catch diode and boot capacitor. Because the PH connection is the switching node, the inductor must be located very close to PH and the area of the PCB conductor minimized to prevent excessive capacitive coupling. The catch diode must also be placed close to the device to minimize the output current loop area. Connect the boot capacitor between the phase node and the BOOT pin as shown. Keep the boot capacitor close to the IC and minimize the conductor trace lengths. The component placements and connections shown work well, but other connection routings can also be effective.

Connect the output filter capacitors as shown between the VOUT trace and GND. Keep the loop formed by PH, L<sub>OUT</sub>, C<sub>OUT</sub>, and GND as small as is practical.

Connect the VOUT trace to the VSENSE pin using the resistor divider network to set the output voltage. Do not route this trace too close to the PH trace. Due to the size of the IC package and the device pin-out, the trace can need to be routed under the output capacitor. Alternately, the routing can be done on an alternate layer if a trace under the output capacitor is not desired.

If using the grounding scheme shown in [Figure 7-12](#), use a via connection to a different layer to route to the ENA pin.

**7.4.2 Layout Example**

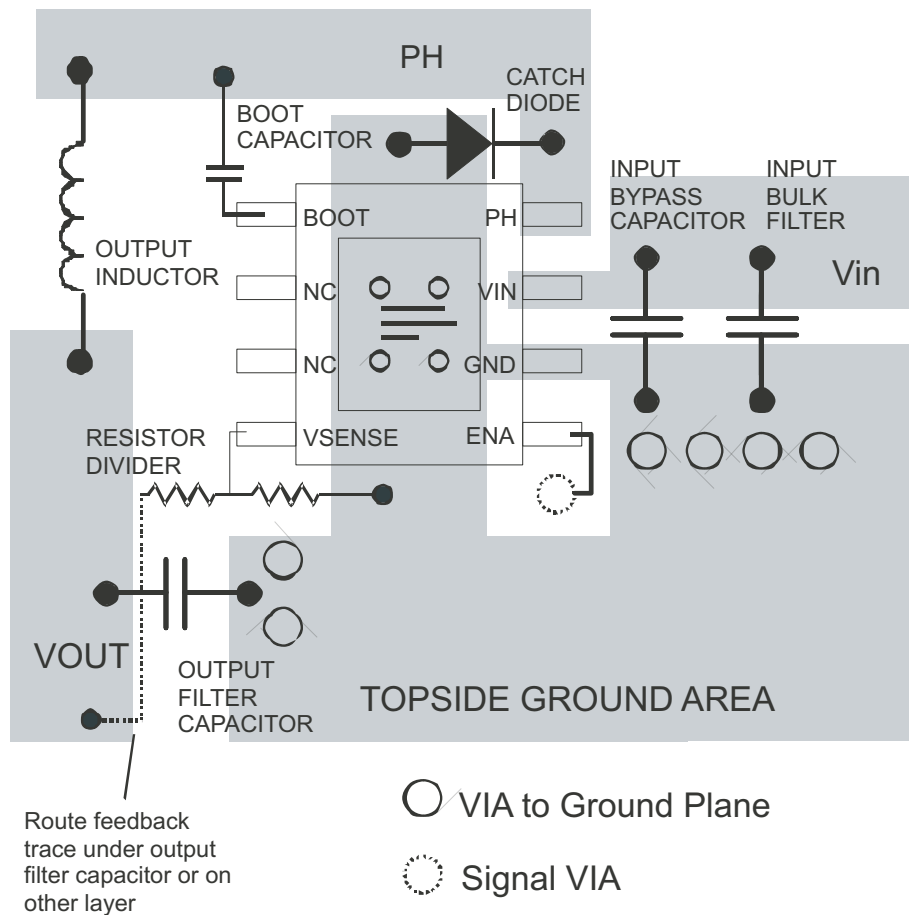

**Figure 7-12. Design Layout**

## 8 Device and Documentation Support

### 8.1 Device Support

#### 8.1.1 Development Support

##### 8.1.1.1 Custom Design With WEBENCH® Tools

[Click here](#) to create a custom design using the TPS5430-Q1 converter with WEBENCH® Power Designer.

1. Start by entering the input voltage ( $V_{IN}$ ), output voltage ( $V_{OUT}$ ), and output current ( $I_{OUT}$ ) requirements.
2. Optimize the design for key parameters such as efficiency, footprint, and cost using the optimizer dial.
3. Compare the generated design with other possible solutions from Texas Instruments.

The WEBENCH Power Designer provides a customized schematic along with a list of materials with real-time pricing and component availability.

In most cases, these actions are available:

- Run electrical simulations to see important waveforms and circuit performance.
- Run thermal simulations to understand board thermal performance.
- Export customized schematic and layout into popular CAD formats.
- Print PDF reports for the design, and share the design with colleagues.

Get more information about WEBENCH tools at [www.ti.com/WEBENCH](http://www.ti.com/WEBENCH).

### 8.2 Documentation Support

#### 8.2.1 Related Documentation

For related documentation, see the following:

Texas Instruments, [Using TPS5410/20/30/31 With Aluminum/Ceramic Output Capacitors](#) application note

### 8.3 Receiving Notification of Documentation Updates

To receive notification of documentation updates, navigate to the device product folder on [ti.com](http://ti.com). Click on *Notifications* to register and receive a weekly digest of any product information that has changed. For change details, review the revision history included in any revised document.

### 8.4 Support Resources

[TI E2E™ support forums](#) are an engineer's go-to source for fast, verified answers and design help — straight from the experts. Search existing answers or ask your own question to get the quick design help you need.

Linked content is provided "AS IS" by the respective contributors. They do not constitute TI specifications and do not necessarily reflect TI's views; see TI's [Terms of Use](#).

### 8.5 Trademarks

PowerPAD™ and TI E2E™ are trademarks of Texas Instruments.

WEBENCH® is a registered trademark of Texas Instruments.

All trademarks are the property of their respective owners.

### 8.6 Electrostatic Discharge Caution



This integrated circuit can be damaged by ESD. Texas Instruments recommends that all integrated circuits be handled with appropriate precautions. Failure to observe proper handling and installation procedures can cause damage.

ESD damage can range from subtle performance degradation to complete device failure. Precision integrated circuits may be more susceptible to damage because very small parametric changes could cause the device not to meet its published specifications.

### 8.7 Glossary

[TI Glossary](#) This glossary lists and explains terms, acronyms, and definitions.

## 9 Revision History

NOTE: Page numbers for previous revisions may differ from page numbers in the current version.

Changes from Revision E (January 2024) to Revision F (April 2026)	Page
• Updated ENA pin description by adding information about internal 1.5MΩ pullup resistor in the <i>Pin Configuration and Functions</i> section.....	3
• Updated VIN pin description by adding information regarding the recommended distance of the bypass capacitor in <i>Pin Configuration and Functions</i> .....	3
• Added note to the Absolute Maximum table allowing BOOT to PH internally generated voltage up to 10V.....	4
• Updated table note 3 in Thermal Information section to include EVM theta JA.....	4
• Added text describing 1.5MΩ pullup resistor in ENA floating use case in <i>Overview</i> .....	8
• Deleted the 5uA current source and added a 1.5MΩ pullup resistor in the functional block diagram.....	9
• Updated the <i>Enable (ENA) and Internal Slow Start</i> section by deleting current information and adding internal 1.5MΩ pullup resistor information.....	9

Changes from Revision D (April 2015) to Revision E (January 2024)	Page
• Updated the numbering format for tables, figures, and cross-references throughout the document.....	1
• Updated the data sheet title to include "Automotive". Added WEBENCH® links throughout the data sheet. Added "integrated circuit" when the PowerPAD package is mentioned. Changed MOSFET resistance from 110 mΩ to 100 mΩ. Changed $I_Q$ from 18 μA to 15 μA.....	1
• Updated notes for Package Information table. Updated precision to two significant digits.....	1
• Changed pin configuration figure title to "DDA Package 8-Pin SOIC With Thermal Pad Top View" and moved the title to the correct position. Changed "PowerPAD" to "DAP" .....	3
• Updated absolute maximum table to new format which does not include specific parameter names and does include min and max columns. $T_J$ called out in header. Pin names are used rather than signal names. BOOT and PH voltages now marked as output voltage. Updated footnotes and removed Note 2.....	4
• Changed BOOT to PH Absolute Maximum from 10 V to 6 V.....	4
• Removed Absolute Maximum BOOT to GND maximum voltage.....	4
• Removed MM ESD.....	4
• Changed CDM ESD from ±1500 V to ±750 V.....	4
• Changed recommended operating " $V_I$ " to "input voltage".....	4
• Updated thermal information footnotes to match current TI standards which include JEDEC standard information. Added EVM $R_{\theta JA}$ information.....	4
• Changed $R_{\theta JA}$ from 41.2 to 42.3, $R_{\theta JC(top)}$ from 44.4 to 46, $R_{\theta JB}$ from 22.1 to 15, $\psi_{JB}$ from 21.9 to 15.3, and $R_{\theta JC(bot)}$ from 3 to 6.....	4
• Added condition for typical specifications EC table's header, added parameter names, and used pin names in parameter descriptions. Footnote added.....	5
• Changed test condition for $V_{FB}$ from " $I_O = 0$ A to 3 A" to " $T_J = -40^\circ\text{C}$ to $125^\circ\text{C}$ ", Changed $r_{DS(ON)}$ to $R_{DS(ON)(HS)}$ and test condition to for $R_{DS(ON)(HS)}$ from " $V_{IN} = 5.5$ V" to " $V_{IN} = 5.5$ V, $V_{BOOT-SW} = 4.0$ V".....	5
• Changed the name of $I_Q$ to $I_{SD(VIN)}$ if ENA is low and $I_{Q(VIN)}$ if the chip is active.....	5
• Added test condition for $D_{MAX}$ , " $f_{SW} = 500$ kHz" and for second $R_{DS(ON)(HS)}$ spec " $V_{IN} = 12$ V, $V_{BOOT-SW} = 4.5$ V".....	5
• Changed $I_{Q(VIN)}$ typical from 3 mA to 2 mA, $I_{SD(VIN)}$ typical from 18 μA to 15 μA, $V_{INUVLO(H)}$ from 330 mV to 0.35 V, and $V_{EN(H)}$ from 450 mV to 325 mV.....	5
• Changed $R_{DS(ON)}$ with $V_{IN} = 5$ V typical from 150 mΩ to 125 mΩ and with $V_{IN} = 12$ V from 110 mΩ to 100 mΩ.....	5
• Changed "110-mΩ high-side MOSFET" to "100-mΩ high-side MOSFET" and 18 μA to 15 μA in <i>Overview</i> ....	8
• Change "PowerPAD" to "DAP" in functional block diagram.....	9
• Changed shutdown current from 18 μA to 15 μA in <i>Enable (ENA) and Internal Slow Start</i> section.....	9
• Changed UVLO hysteresis from 330mV to 350mV in UVLO description.....	10

---

- Changed "PwPd" to "DAP" on the TPS5430DDA package drawing in [Figure 7-1](#) and "exposed thermal pad" to "DAP" in circuit description. .... 12
- Added "Custom Design With WEBENCH® Tools" section..... 13
- Changed "PwPd" to "DAP" on the TPS5430DDA package drawing in [Figure 7-9](#) and [Figure 7-10](#)..... 19
- Changed "PwPd" to "DAP" on the TPS5430DDA package drawing in [Figure 7-11](#)..... 20
- Deleted land pattern from *Layout Example* section..... 22
- Added "Custom Design With WEBENCH® Tools" section..... 23

---

## 10 Mechanical, Packaging, and Orderable Information

The following pages include mechanical, packaging, and orderable information. This information is the most current data available for the designated devices. This data is subject to change without notice and revision of this document. For browser-based versions of this data sheet, refer to the left-hand navigation.

**PACKAGING INFORMATION**

Orderable part number	Status (1)	Material type (2)	Package   Pins	Package qty   Carrier	RoHS (3)	Lead finish/ Ball material (4)	MSL rating/ Peak reflow (5)	Op temp (°C)	Part marking (6)
<a href="#">TPS5430QDDARQ1</a>	Active	Production	SO PowerPAD (DDA)   8	2500   LARGE T&R	Yes	NIPDAUAG	Level-2-260C-1 YEAR	-40 to 125	5430Q
TPS5430QDDARQ1.A	Active	Production	null (null)	2500   LARGE T&R	-	NIPDAUAG	Level-2-260C-1 YEAR	See TPS5430QDDARQ1	5430Q

<sup>(1)</sup> **Status:** For more details on status, see our [product life cycle](#).

<sup>(2)</sup> **Material type:** When designated, preproduction parts are prototypes/experimental devices, and are not yet approved or released for full production. Testing and final process, including without limitation quality assurance, reliability performance testing, and/or process qualification, may not yet be complete, and this item is subject to further changes or possible discontinuation. If available for ordering, purchases will be subject to an additional waiver at checkout, and are intended for early internal evaluation purposes only. These items are sold without warranties of any kind.

<sup>(3)</sup> **RoHS values:** Yes, No, RoHS Exempt. See the [TI RoHS Statement](#) for additional information and value definition.

<sup>(4)</sup> **Lead finish/Ball material:** Parts may have multiple material finish options. Finish options are separated by a vertical ruled line. Lead finish/Ball material values may wrap to two lines if the finish value exceeds the maximum column width.

<sup>(5)</sup> **MSL rating/Peak reflow:** The moisture sensitivity level ratings and peak solder (reflow) temperatures. In the event that a part has multiple moisture sensitivity ratings, only the lowest level per JEDEC standards is shown. Refer to the shipping label for the actual reflow temperature that will be used to mount the part to the printed circuit board.

<sup>(6)</sup> **Part marking:** There may be an additional marking, which relates to the logo, the lot trace code information, or the environmental category of the part.

Multiple part markings will be inside parentheses. Only one part marking contained in parentheses and separated by a "-" will appear on a part. If a line is indented then it is a continuation of the previous line and the two combined represent the entire part marking for that device.

**Important Information and Disclaimer:** The information provided on this page represents TI's knowledge and belief as of the date that it is provided. TI bases its knowledge and belief on information provided by third parties, and makes no representation or warranty as to the accuracy of such information. Efforts are underway to better integrate information from third parties. TI has taken and continues to take reasonable steps to provide representative and accurate information but may not have conducted destructive testing or chemical analysis on incoming materials and chemicals. TI and TI suppliers consider certain information to be proprietary, and thus CAS numbers and other limited information may not be available for release.

In no event shall TI's liability arising out of such information exceed the total purchase price of the TI part(s) at issue in this document sold by TI to Customer on an annual basis.

**OTHER QUALIFIED VERSIONS OF TPS5430-Q1 :**

- Catalog : [TPS5430](#)
- Enhanced Product : [TPS5430-EP](#)

NOTE: Qualified Version Definitions:

- Catalog - TI's standard catalog product
- Enhanced Product - Supports Defense, Aerospace and Medical Applications

**TAPE AND REEL INFORMATION**

**QUADRANT ASSIGNMENTS FOR PIN 1 ORIENTATION IN TAPE**

\*All dimensions are nominal

Device	Package Type	Package Drawing	Pins	SPQ	Reel Diameter (mm)	Reel Width W1 (mm)	A0 (mm)	B0 (mm)	K0 (mm)	P1 (mm)	W (mm)	Pin1 Quadrant
TPS5430QDDARQ1	SO PowerPAD	DDA	8	2500	330.0	12.8	6.4	5.2	2.1	8.0	12.0	Q1

**TAPE AND REEL BOX DIMENSIONS**



\*All dimensions are nominal

Device	Package Type	Package Drawing	Pins	SPQ	Length (mm)	Width (mm)	Height (mm)
TPS5430QDDARQ1	SO PowerPAD	DDA	8	2500	518.0	364.0	84.0

**TUBE**

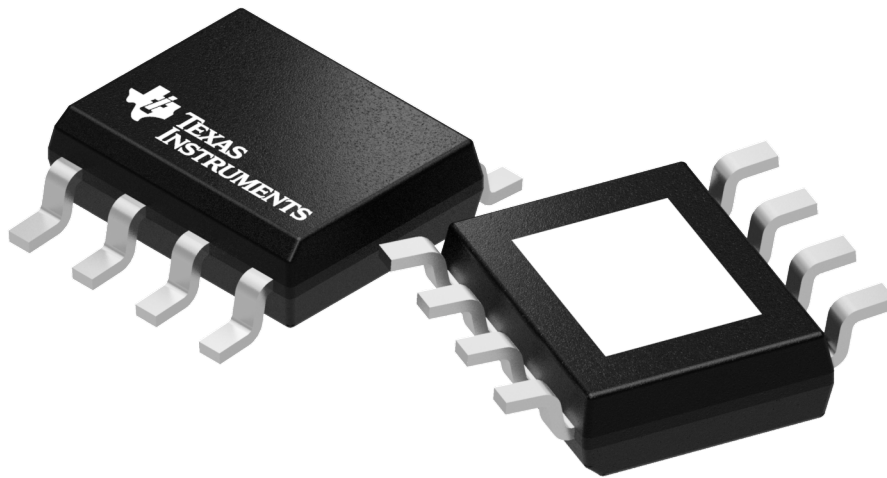

\*All dimensions are nominal

Device	Package Name	Package Type	Pins	SPQ	L (mm)	W (mm)	T (μm)	B (mm)
TPS5430QDDARQ1	DDA	HSOIC	8	2500	508	12.19	510	7.88
TPS5430QDDARQ1.A	DDA	HSOIC	8	2500	508	12.19	510	7.88

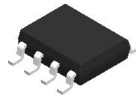

Images above are just a representation of the package family, actual package may vary.  
Refer to the product data sheet for package details.

DDA0008J



# PACKAGE OUTLINE

PowerPAD™ SOIC - 1.7 mm max height

PLASTIC SMALL OUTLINE

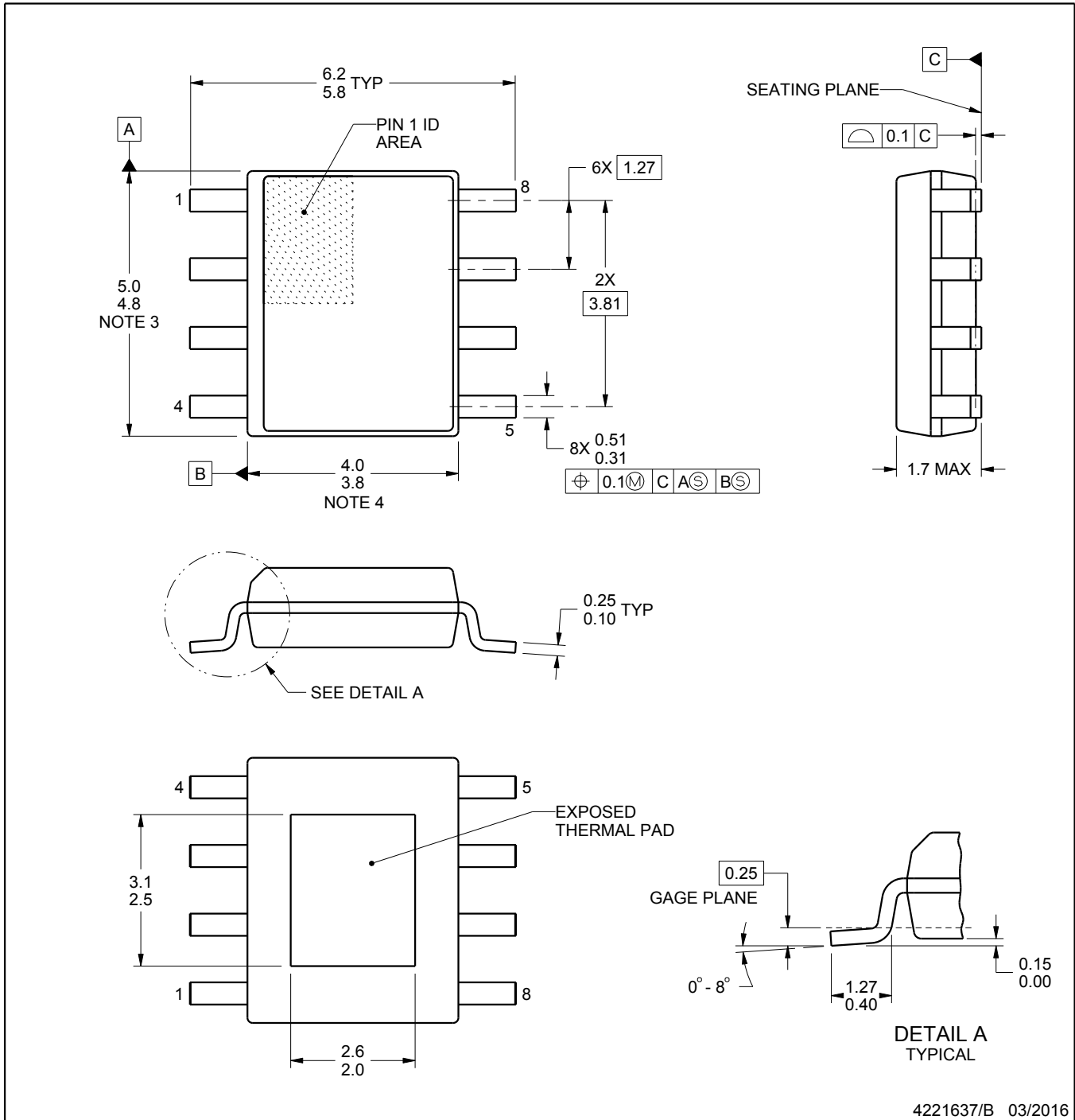

4221637/B 03/2016

PowerPAD is a trademark of Texas Instruments.

**NOTES:**

1. All linear dimensions are in millimeters. Any dimensions in parenthesis are for reference only. Dimensioning and tolerancing per ASME Y14.5M.
2. This drawing is subject to change without notice.
3. This dimension does not include mold flash, protrusions, or gate burrs. Mold flash, protrusions, or gate burrs shall not exceed 0.15 mm per side.
4. This dimension does not include interlead flash. Interlead flash shall not exceed 0.25 mm per side.
5. Reference JEDEC registration MS-012, variation BA.

# EXAMPLE BOARD LAYOUT

DDA0008J

PowerPAD™ SOIC - 1.7 mm max height

PLASTIC SMALL OUTLINE

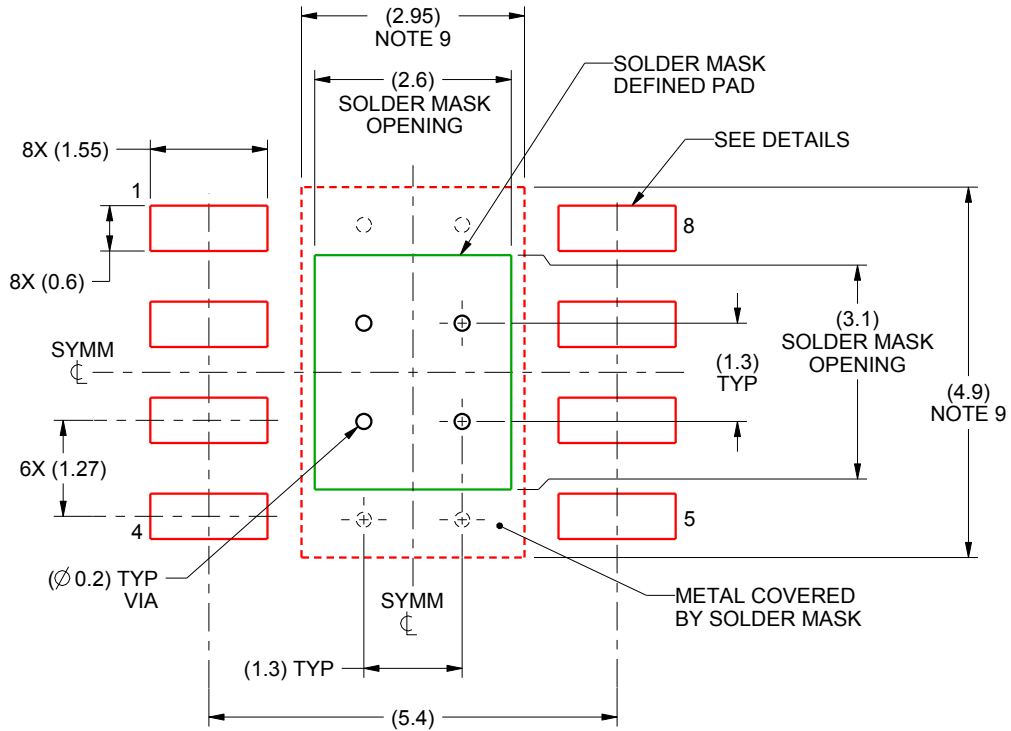

LAND PATTERN EXAMPLE  
SCALE:10X

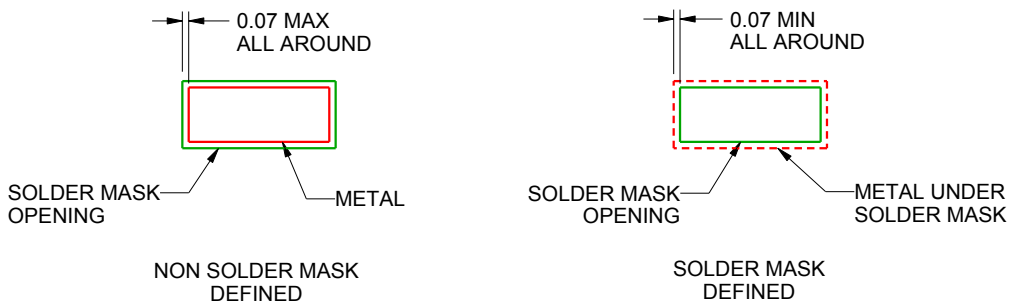

SOLDER MASK DETAILS

4221637/B 03/2016

NOTES: (continued)

- 6. Publication IPC-7351 may have alternate designs.
- 7. Solder mask tolerances between and around signal pads can vary based on board fabrication site.
- 8. This package is designed to be soldered to a thermal pad on the board. For more information, see Texas Instruments literature numbers SLMA002 ([www.ti.com/lit/slma002](http://www.ti.com/lit/slma002)) and SLMA004 ([www.ti.com/lit/slma004](http://www.ti.com/lit/slma004)).
- 9. Size of metal pad may vary due to creepage requirement.

# EXAMPLE STENCIL DESIGN

DDA0008J

PowerPAD™ SOIC - 1.7 mm max height

PLASTIC SMALL OUTLINE

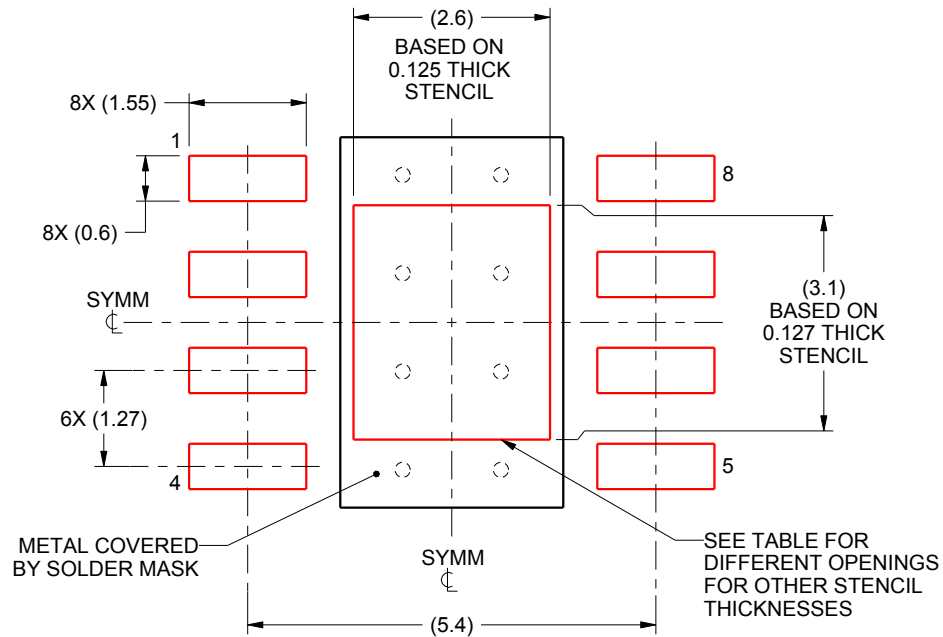

SOLDER PASTE EXAMPLE  
EXPOSED PAD  
100% PRINTED SOLDER COVERAGE BY AREA  
SCALE:10X

STENCIL THICKNESS	SOLDER STENCIL OPENING
0.1	2.91 X 3.47
0.125	2.6 X 3.1 (SHOWN)
0.150	2.37 X 2.83
0.175	2.20 X 2.62

4221637/B 03/2016

NOTES: (continued)

10. Laser cutting apertures with trapezoidal walls and rounded corners may offer better paste release. IPC-7525 may have alternate design recommendations.
11. Board assembly site may have different recommendations for stencil design.

## IMPORTANT NOTICE AND DISCLAIMER

TI PROVIDES TECHNICAL AND RELIABILITY DATA (INCLUDING DATASHEETS), DESIGN RESOURCES (INCLUDING REFERENCE DESIGNS), APPLICATION OR OTHER DESIGN ADVICE, WEB TOOLS, SAFETY INFORMATION, AND OTHER RESOURCES "AS IS" AND WITH ALL FAULTS, AND DISCLAIMS ALL WARRANTIES, EXPRESS AND IMPLIED, INCLUDING WITHOUT LIMITATION ANY IMPLIED WARRANTIES OF MERCHANTABILITY, FITNESS FOR A PARTICULAR PURPOSE OR NON-INFRINGEMENT OF THIRD PARTY INTELLECTUAL PROPERTY RIGHTS.

These resources are intended for skilled developers designing with TI products. You are solely responsible for (1) selecting the appropriate TI products for your application, (2) designing, validating and testing your application, and (3) ensuring your application meets applicable standards, and any other safety, security, regulatory or other requirements.

These resources are subject to change without notice. TI grants you permission to use these resources only for development of an application that uses the TI products described in the resource. Other reproduction and display of these resources is prohibited. No license is granted to any other TI intellectual property right or to any third party intellectual property right. TI disclaims responsibility for, and you fully indemnify TI and its representatives against any claims, damages, costs, losses, and liabilities arising out of your use of these resources.

TI's products are provided subject to [TI's Terms of Sale](#), [TI's General Quality Guidelines](#), or other applicable terms available either on [ti.com](#) or provided in conjunction with such TI products. TI's provision of these resources does not expand or otherwise alter TI's applicable warranties or warranty disclaimers for TI products. Unless TI explicitly designates a product as custom or customer-specified, TI products are standard, catalog, general purpose devices.

TI objects to and rejects any additional or different terms you may propose.

Copyright © 2026, Texas Instruments Incorporated

Last updated 10/2025