



Rubas Khalid, Grant Wilson

ABSTRACT

Heating, ventilation, and air conditioning (HVAC) systems consist of subsystems that require a switching power device. Depending on the subsystem, different challenges arise when selecting a gate driver IC to drive the switching power device. This application note reviews the power factor correction (PFC), motor drive, and DC/DC switching converter stages in HVAC systems, summarizes the switching requirements for each stage, and provides examples of non-isolated gate drivers that can be used to drive the switching power devices found in the aforementioned stages.

Table of Contents

1 Introduction	2
2 PFC Stage	3
2.1 Boost PFC.....	3
2.2 Interleaved Boost PFC.....	4
3 Motor Drive Stage	5
3.1 Standalone Gate Drivers vs. IPM.....	5
3.2 Driving Three-Phase Motors.....	6
3.3 Higher Power Levels for Commercial HVAC.....	7
4 DC/DC Stage	8
4.1 Synchronous Buck Converter.....	8
4.2 Flyback Converters.....	9
5 Summary	9
6 References	9
7 Revision History	10

Trademarks

All trademarks are the property of their respective owners.

1 Introduction

HVAC systems are used to maintain a comfortable environment inside industrial, commercial, and residential buildings. HVAC systems are typically used to control the air in the environment and consist of ventilation systems, heating systems, and air-cooling systems.

For more HVAC applications, Texas Instruments covers a variety of applications found in the [HVAC system applications page](#).

Modern HVAC systems use gate drivers in different subsystems, such as power factor correction (PFC) circuits, DC/DC converters, and motor drives. This application note discusses the usage of gate drivers in industrial, commercial, and residential HVAC systems, including guidelines in selecting a gate driver and key features to consider for each subsystem. [Figure 1-1](#) shows a block diagram of an outdoor air conditioner and highlights typical subsystems where gate drivers are used.

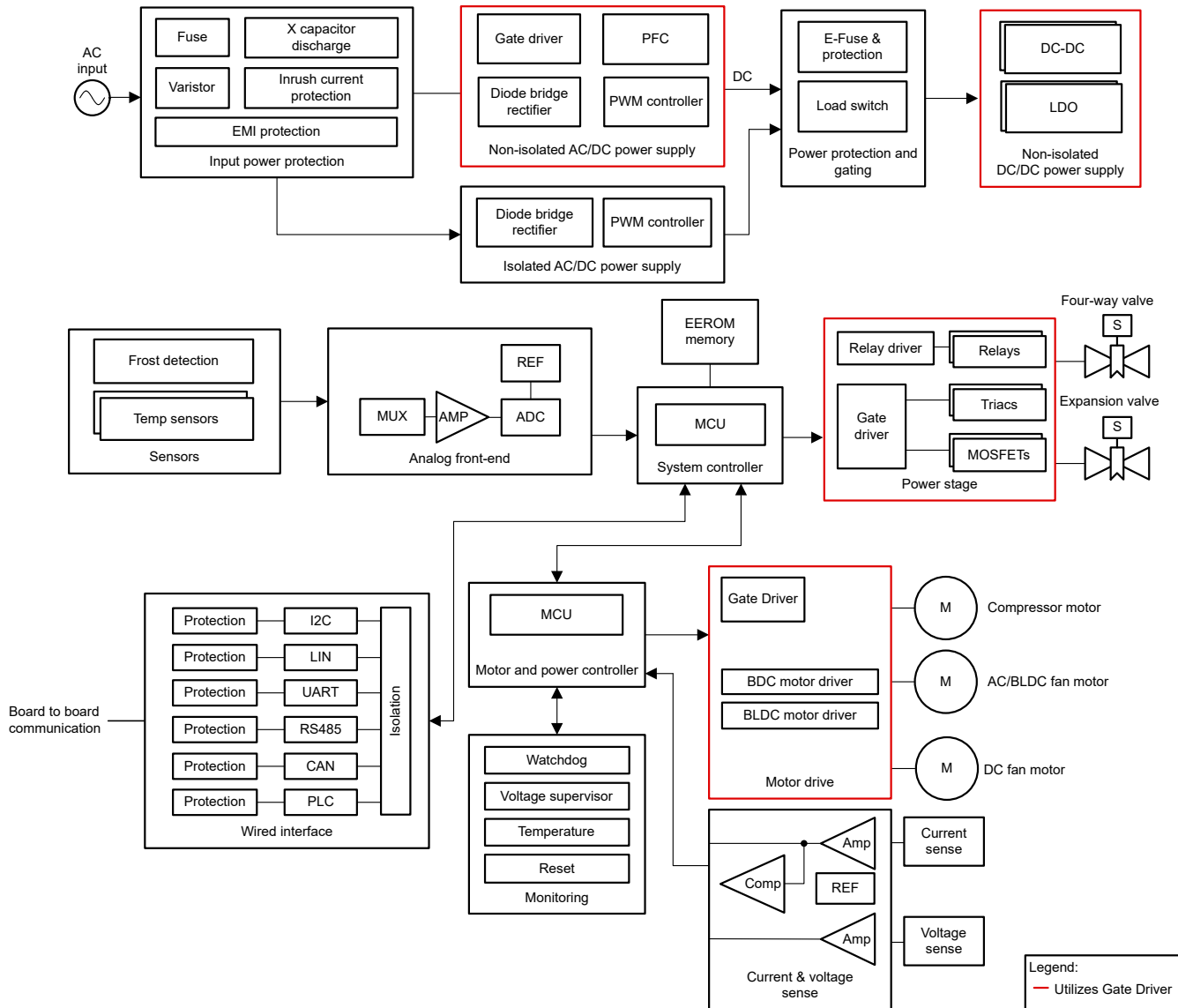

Figure 1-1. Outdoor Air Conditioner Block Diagram

2 PFC Stage

In HVAC systems using AC power, a high-power factor is a key requirement. Power factor is the ratio of real power over apparent power, and apparent power is a combination of real and reactive power. The load only consumes real power; therefore, it is critical that the losses from reactive power are minimized as much as possible. The lower the loss, the more efficient HVAC systems can be, and PFCs are used to maximize the power factor ratio.

2.1 Boost PFC

PFCs are a key power stage in HVAC systems, and the most common PFC topology used in HVAC systems is the boost PFC. The boost PFC topology utilizes a full-bridge rectifier to first rectify the AC line voltage, and then a boost converter is used to step up the rectified voltage to a desired DC bus voltage. This topology consists of a single FET referenced to ground, requiring a low-side gate driver. [Figure 2-1](#) shows an example of the boost PFC.

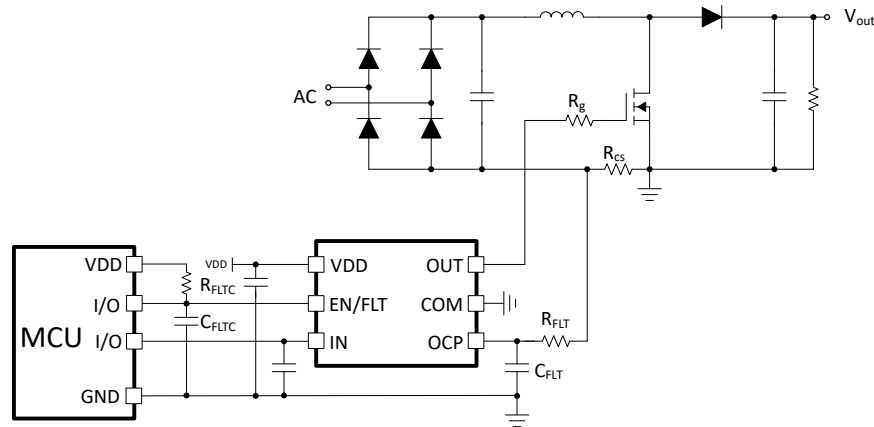

Figure 2-1. Boost PFC with UCC5714x

Selecting a gate driver to drive the FET in HVAC PFC circuits requires careful consideration. Parasitic inductance and electromagnetic interference in HVAC systems can potentially cause damaging or destructive negative voltages that can affect gate drivers. To help circumvent this issue, it is important to select a gate driver with negative voltage capability to increase the robustness of the system. Another requirement to consider when designing high efficiency HVAC PFC circuit is peak drive current. A high peak drive current helps to achieve fast rise and fall time of the FET. This reduces voltage and current overlapping, which reduces switching losses to help HVAC systems achieve higher efficiency. Another consideration is the size of the gate driver IC. A smaller package allows the gate driver IC to be placed closer to the power FET, which reduces parasitic inductance due to PCB traces.

The UCC5714x can be used to drive the FET in a boost PFC for HVAC systems. The UCC5714x has peak output current of 3A source and 3A sink and is rated up to 30V VDD. Furthermore, the driver has a rise time of 8ns, fall time of 14ns, and propagation delay of 26ns for fast and efficient switching in HVAC systems. The UCC5714x also has negative voltage capability, under-voltage lockout (UVLO), and integrated over-current protection (OCP) for added robustness. Refer to this [app note](#) for a greater explanation of how OCP benefits end systems. [Table 2-1](#) features a comparison between UCC5714x and the leading competitors.

Table 2-1. Comparison of UCC5714x and Leading Competitors

Design Considerations	UCC5714x	Competitor 1	Competitor 2
Supply Voltage (V _{DD}) <i>Absolute maximum</i>	30V	25V	25V
Negative Voltage Handling	-5V	-5V	-5V
UVLO	8V / 12V	12V	8V
Source/Sink Current <i>Typical</i>	3A / 3A	2.6A / 2.4A	2.6A / 2.6A
Rise/Fall Time <i>Typical</i>	8ns / 14ns @1.8nF load	5ns / 5ns @1.0nF load	5ns / 5ns @1.0nF load
Propagation Delay On/Off <i>Typical</i>	26ns	15ns	50ns
OC blanking time <i>Typical</i>	180ns	250ns	180ns
Package	SOT-23, 6-pin	SOT-23, 6-pin	SOT-23, 6-pin

2.2 Interleaved Boost PFC

The interleaved boost PFC is an alternate PFC topology used in HVAC systems. The interleaved boost PFC features two boost converters operating 180 degrees out of phase and is typically used for higher power applications. This topology can also offer efficiency improvements at the cost of additional components. The gate driver requirements for this topology is similar to the traditional boost PFC; however, an additional low-side FET is needed for the second boost converter. To achieve this, a dual-channel low-side gate driver is commonly used. Figure 2-2 shows an example of an interleaved boost PFC.

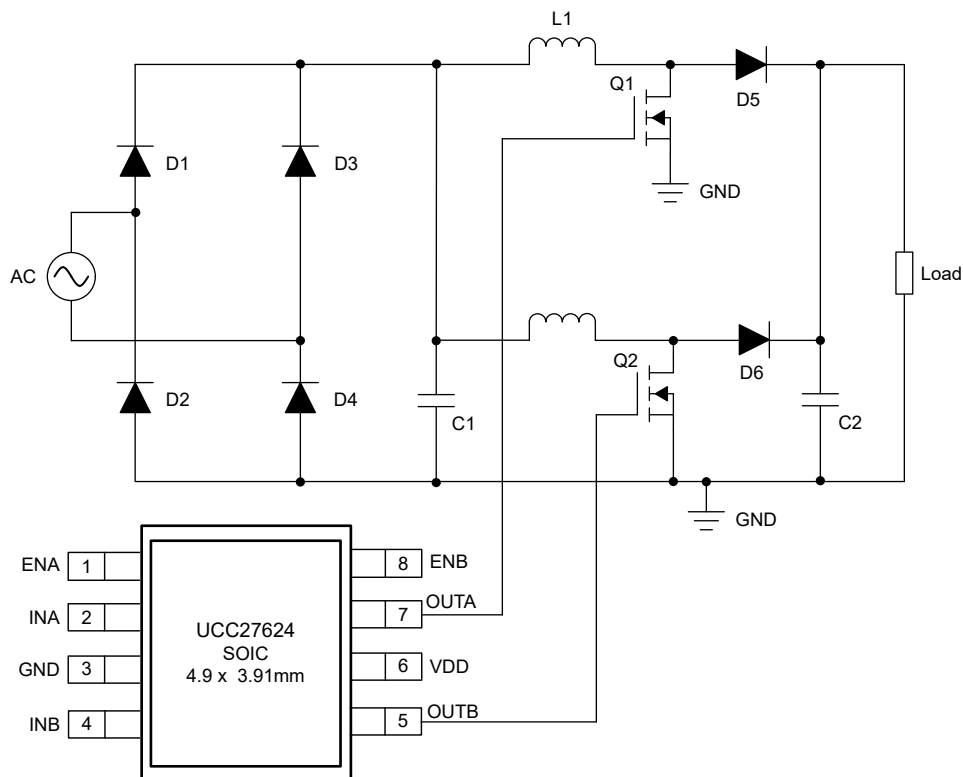

Figure 2-2. Interleaved Boost PFC with UCC27624

The UCC27624 can be used to drive the FETs in an interleaved boost PFC. Each of the two channels has a high drive strength, capable of outputting 5A source and 5A sink peak currents. This driver is also rated up to 30V VDD, allowing for greater flexibility in design. Furthermore, the driver has a rise time of 6ns, fall time of 10ns, propagation delay of 17ns, and delay matching of 1ns to for fast and efficient switching in HVAC systems. Table 2-2 features a comparison between UCC27624 and the leading competitors

Table 2-2. Comparison of UCC27624 and Leading Competitors

Design Considerations	UCC27624	Competitor 1	Competitor 2
Supply Voltage (V_{DD}) <i>Absolute maximum</i>	30V	24V	25V
Negative Voltage Handling	-10V	-6V	-6V
UVLO	4V	4V	4V
Source/Sink Current <i>Typical</i>	5A / 5A	5A / 5A	4.5A / 5.5A
Rise/Fall Time <i>Typical</i>	6ns / 10ns	8ns / 8ns	7ns / 6ns
Propagation Delay On/Off <i>Typical</i>	17ns / 17ns	20ns / 20ns	18ns / 18ns
Delay Matching <i>Maximum</i>	2ns	4ns	4ns
Package	SOIC, 8-pin	SOIC, 8-pin	SOIC, 8-pin

3 Motor Drive Stage

Motors in HVAC systems are integral to power different HVAC applications, such as fans, compressors, and pumps. These systems typically include different types of motors, such as brushed DC, brushless DC, and stepper. Motor drives are implemented with different degrees of integration, from using standalone gate driver ICs to a fully integrated intelligent power module (IPM).

3.1 Standalone Gate Drivers vs. IPM

Motor drive IPMs include three drivers and three FETs amongst other components that are integrated into one package, providing features such as fault detection, over temperature prevention, and current sensing. While these devices offer a lot, they do have their disadvantages. Since many components are stuffed into one package, thermal performance can degrade at higher power levels. A standalone gate driver IC with external FETs can spread heat more effectively, benefiting high-power HVAC applications. Higher maximum voltage and current specifications can also be achieved by using the same standalone gate driver IC with Lower RDSon external FETs, while IPMs are typically bottlenecked to their specified rating.

As mentioned, one benefit of designing discretely is that the FETs and their respective standalone gate driver ICs may be placed optimally for board layout and thermal needs. With proper layout, pairing a standalone gate driver IC as close as possible to the external FET will minimize trace lengths, leading to a reduction in switching losses and EMI. This provides flexibility to the engineer, allowing optimization of overall board performance. Additionally, standalone gate driver ICs are heavily multisource, meaning most devices will have a competitor that matches its pinout and key specs. This provides the engineer the ability to drop in other solutions as needed if their current vendor runs into supply concerns. In contrast, IPMs tend to be unique and do not have direct replacements available in the market.

3.2 Driving Three-Phase Motors

Motors in HVAC systems are used to power fans, compressors, and valves. Depending on the motor application, key specifications, like voltage and peak current, and driver robustness are important to consider when selecting a gate driver. A gate driver with low peak current works best for a low-power application, while a gate driver with high peak current works best for a high-power application. Interlock can protect against cross-conduction or shoot-through in half-bridge drives, which can occur by parasitic ringing at the input. A gate driver with negative voltage capability adds robustness to the driver, as negative voltages can occur with transients arising from parasitic inductance. **Figure 3-1** shows a typical three-phase inverter motor drive topology.

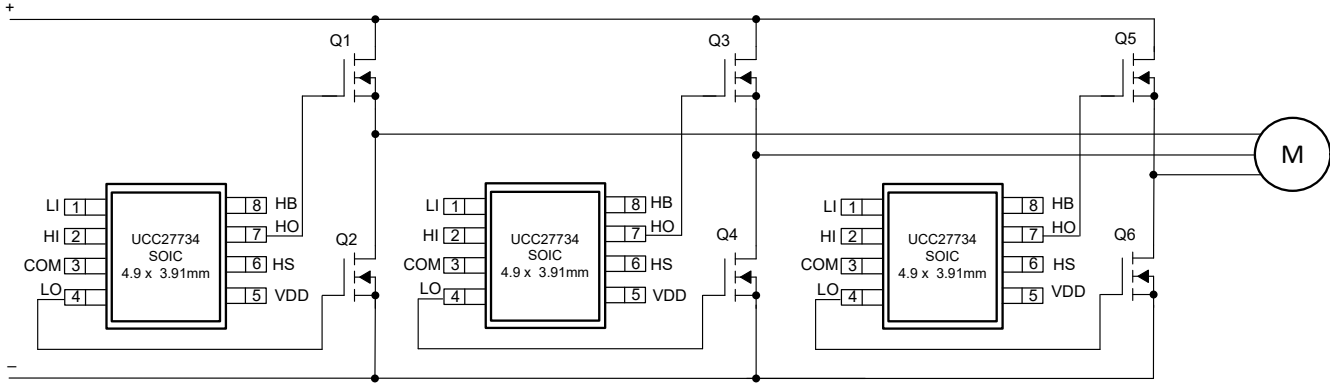

Figure 3-1. Three-Phase Inverter Motor Drive with UCC27734

For half-bridge motor drives, the UCC27710 or UCC27734 can be used to drive low-power applications, roughly less than 5kW. Both the UCC27710 and UCC27734 are part of the 700V family of half-bridge drivers, featuring interlock to prevent both high and low outputs from being on at the same time, and have negative voltage capability on the input pins for added robustness. In comparison to the UCC27710 and UCC27734, the UCC27735 is available in a larger 14-pin package to accommodate larger creepage requirements.

3.3 Higher Power Levels for Commercial HVAC

Industrial HVAC systems are very similar to residential HVAC systems, with the main difference being size and power level of the system. Commercial buildings often have access to three-phase power, meaning the AC voltage is higher. Thus the DC voltage output from the PFC is higher as well, typically 800V. Though isolated gate drivers are often used to drive the high-side of the 800V bus voltage systems, a non-isolated gate driver can be implemented on the low-side to offer cost-savings. Further, a non-isolated gate driver can also be used to drive the high-side when paired with a digital isolator. [Figure 3-2](#) shows the UCC57108C implemented in both low-side and high-side.

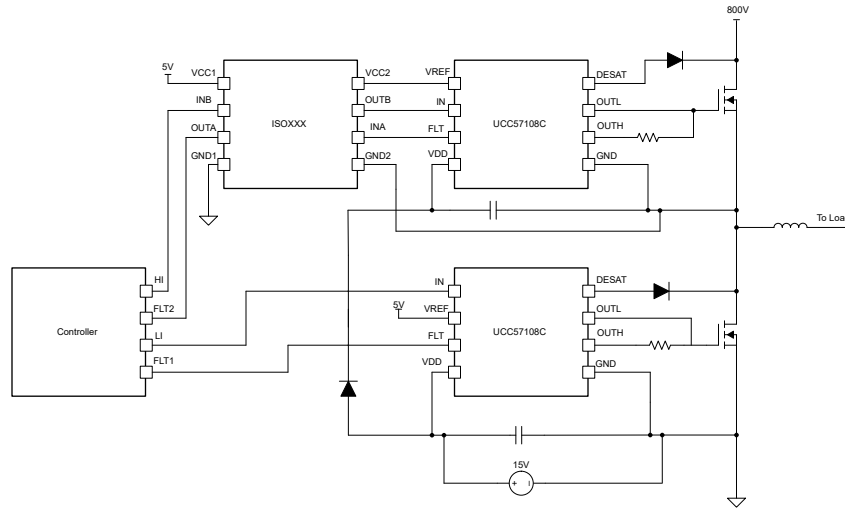

Figure 3-2. Low-Side Driver with Digital Isolator to Create a Half-Bridge

Higher power systems often use IGBTs and Silicon Carbide (SiC) FETs. To protect these higher switching power devices, TI offers the [UCC57108](#) (8V UVLO) and [UCC57102](#) (12V UVLO), which are low-side gate drivers with desaturation (DESAT) protection. DESAT protection uses internal circuitry to detect short-circuit events, shutting down the gate driver output to protect the switching power device. To understand more about DESAT protection, read [Understanding the Short Circuit Protection for Silicon Carbide MOSFETs](#).

4 DC/DC Stage

DC/DC switching converters in HVAC systems are used to efficiently shift voltage levels for different applications. Like motor drives, there are different integration levels to consider when designing DC/DC converters, from standalone gate driver IC to full integration. The advantages in selecting a gate driver IC to drive power devices is akin to selecting a gate driver IC to drive motor drives. To summarize, gate driver ICs can provide better thermal performance, potential for higher power, and less EMI with proper PCB layout.

Switching efficiency is a critical requirement for DC/DC converters in HVAC systems. Compared to motor drives, DC/DC converters run at a much higher switching frequency. Higher switching frequencies reduces output ripple and the size of transformers and inductors, but often with the caveat of switching losses. A gate driver with high peak currents is often sought after when selecting a gate driver to drive DC/DC converters, as high peak currents can allow for a faster rise and fall time, which reduces switching losses for an increase in system efficiency.

4.1 Synchronous Buck Converter

The synchronous buck converter is a common DC/DC converter used in HVAC systems, and are also used in HVAC end equipment, such as thermostats, controllers, and sensors. Synchronous buck converters increase efficiency by replacing the diode referenced to ground in a regular buck topology with a switching power device. This DC/DC converter topology uses a switching power device on the low-side and high-side, requiring a half-bridge driver. [Figure 4-1](#) shows an example of a synchronous buck converter.

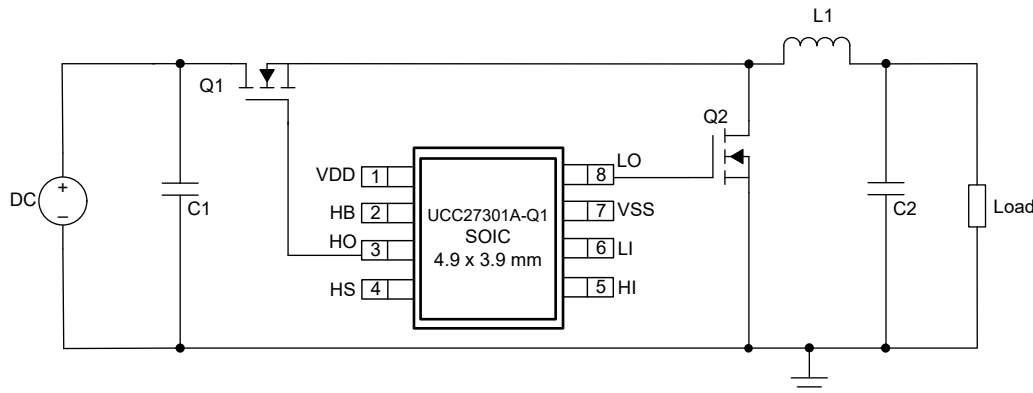

Figure 4-1. Synchronous Buck Converter with UCC27301A-Q1

The UCC27311A-Q1 can be used to drive the switching power devices in a synchronous buck converter. The driver has a high drive strength of 4.5A peak source current and 3.7A peak sink current. This high drive strength allows for a fast rise and fall time, which reduces switching losses and ultimately increase the efficiency of the switching converter. The UCC27311A-Q1 also has negative voltage handling on the input pins for added robustness. The UCC27301A-Q1 is a similar driver to the UCC27311A-Q1, but has interlock for added protection against cross-conduction. Both the UCC27311A-Q1 and UCC27301A-Q1 have an integrated bootstrap diode.

4.2 Flyback Converters

The flyback converter is another DC/DC topology used in HVAC systems. Diode bridge rectification is first used to rectify 120V or 230VAC input, which is then chopped by a switching power device, and then finally goes through the transformer to be converted into lower voltage rails. In a flyback converter, the switching power device used to chop the primary side DC voltage is referenced to ground, requiring a low-side driver. [Figure 4-2](#) shows an example of a flyback converter.

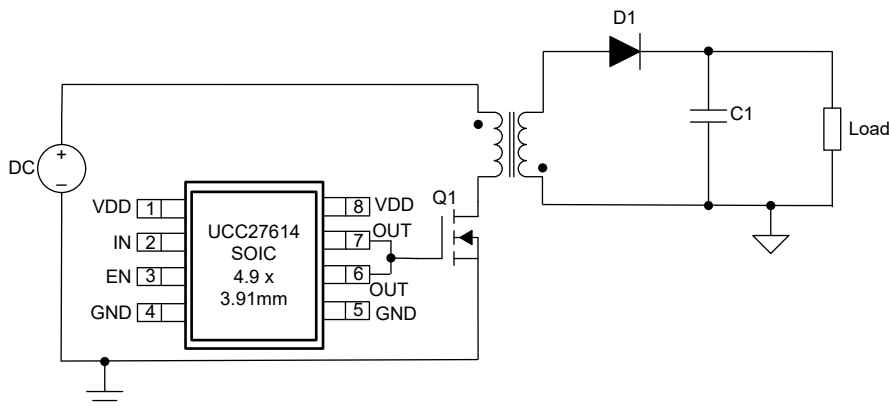

Figure 4-2. Flyback Converter with UCC27614

The UCC27614 can be used to drive the switching power device in a flyback converter. The UCC27614 features a high VDD rating of 30V to allow for flexibility in system design, and the UCC27614 also has a high drive strength of 10A peak source and sink current to increase switching efficiency. The driver also has a negative voltage capability for added robustness. The UCC44273 can also be used as a low quiescent option for designs that require a lower power consumption or smaller footprint.

5 Summary

Modern day HVAC systems consist of different power stages and motor drives that can require a gate driver. Texas Instruments offers a number of gate drivers to fit HVAC needs. The large portfolio of low-side gate drivers can be used in critical areas of HVAC systems, such as the PFC stage. Alongside low-side drivers, Texas Instruments also offers numerous half-bridge drivers used in motor drivers for applications such as fans, compressors, and pumps. Texas Instruments gate driver portfolio can also be used in DC/DC converters in HVAC systems and end equipment, such as thermostats, controllers, and sensors. With a high-performance and competitive portfolio of gate drivers, HVAC systems can be smaller, robust, and efficient.

6 References

- Texas Instruments, [HVAC System](#), product page.
- [Review of Different Power Factor Correction \(PFC\) Topologies' Gate Driver Needs](#), application note.
- Texas Instruments, [How to Choose a Gate Driver for DC Motor Drives](#), application note.
- Texas Instruments, [Selecting the right level of integration to meet motor design requirements](#), technical article.
- Texas Instruments, [How the Switching Frequency Affects the Performance of a Buck Converter](#), application note.

7 Revision History

Changes from Revision * (April 2024) to Revision A (November 2025)	Page
• Updated the numbering format for tables, figures, and cross-references throughout the document.....	2
• Replaced the figure and device rec to include new device with protection feature (dropped UCC44273).....	3
• Changed comparison tables.....	3
• Created new sub-sections to better explain the IPM v discrete gate drivers. Updated Figure 3-1 to include new device, similar diagram.....	5
• Added new section and figure.....	7

IMPORTANT NOTICE AND DISCLAIMER

TI PROVIDES TECHNICAL AND RELIABILITY DATA (INCLUDING DATASHEETS), DESIGN RESOURCES (INCLUDING REFERENCE DESIGNS), APPLICATION OR OTHER DESIGN ADVICE, WEB TOOLS, SAFETY INFORMATION, AND OTHER RESOURCES "AS IS" AND WITH ALL FAULTS, AND DISCLAIMS ALL WARRANTIES, EXPRESS AND IMPLIED, INCLUDING WITHOUT LIMITATION ANY IMPLIED WARRANTIES OF MERCHANTABILITY, FITNESS FOR A PARTICULAR PURPOSE OR NON-INFRINGEMENT OF THIRD PARTY INTELLECTUAL PROPERTY RIGHTS.

These resources are intended for skilled developers designing with TI products. You are solely responsible for (1) selecting the appropriate TI products for your application, (2) designing, validating and testing your application, and (3) ensuring your application meets applicable standards, and any other safety, security, regulatory or other requirements.

These resources are subject to change without notice. TI grants you permission to use these resources only for development of an application that uses the TI products described in the resource. Other reproduction and display of these resources is prohibited. No license is granted to any other TI intellectual property right or to any third party intellectual property right. TI disclaims responsibility for, and you fully indemnify TI and its representatives against any claims, damages, costs, losses, and liabilities arising out of your use of these resources.

TI's products are provided subject to [TI's Terms of Sale](#), [TI's General Quality Guidelines](#), or other applicable terms available either on ti.com or provided in conjunction with such TI products. TI's provision of these resources does not expand or otherwise alter TI's applicable warranties or warranty disclaimers for TI products. Unless TI explicitly designates a product as custom or customer-specified, TI products are standard, catalog, general purpose devices.

TI objects to and rejects any additional or different terms you may propose.

Copyright © 2025, Texas Instruments Incorporated

Last updated 10/2025