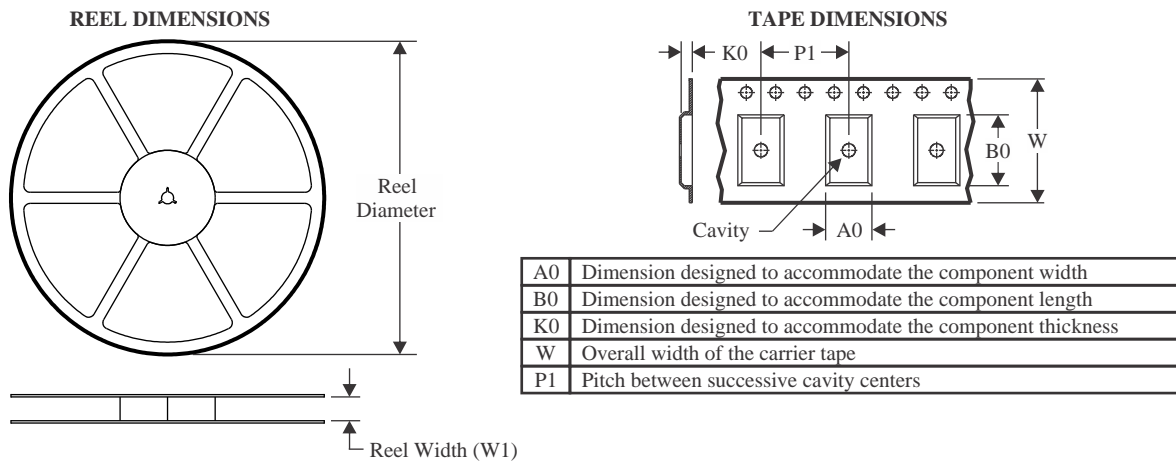
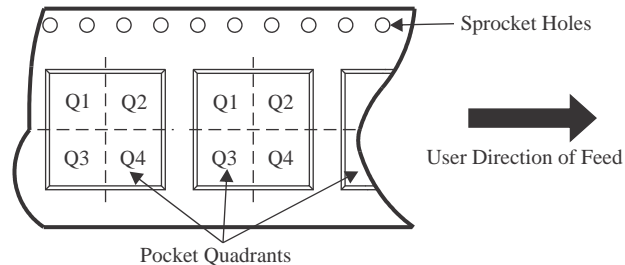
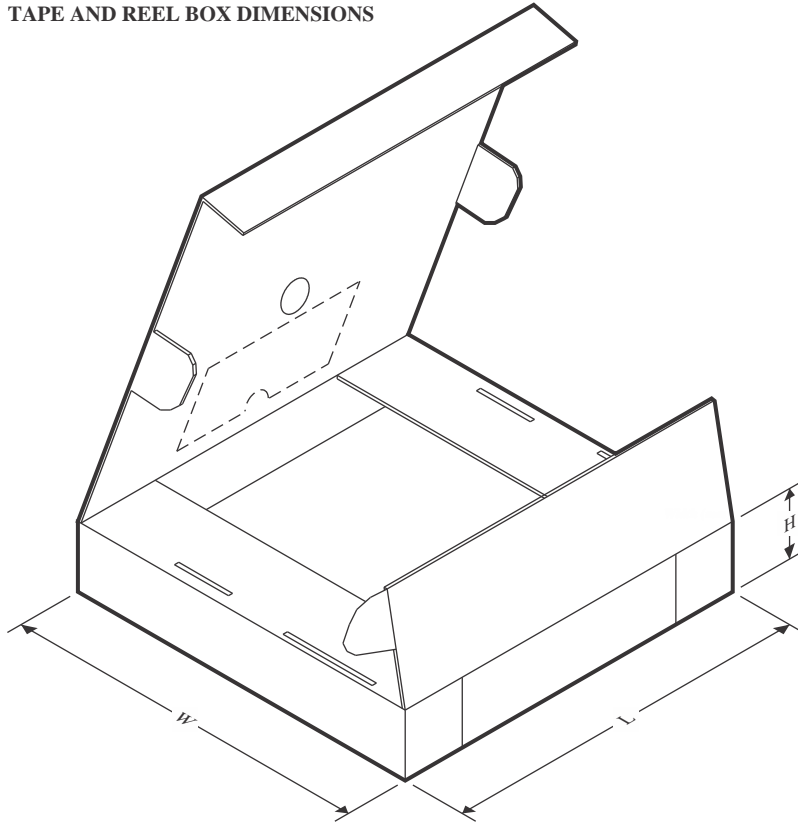

TAPE AND REEL INFORMATION

QUADRANT ASSIGNMENTS FOR PIN 1 ORIENTATION IN TAPE

*All dimensions are nominal

Device	Package Type	Package Drawing	Pins	SPQ	Reel Diameter (mm)	Reel Width W1 (mm)	A0 (mm)	B0 (mm)	K0 (mm)	P1 (mm)	W (mm)	Pin1 Quadrant
OPA2388IDGKR	VSSOP	DGK	8	2500	330.0	12.4	5.25	3.35	1.25	8.0	12.0	Q1
OPA2388IDGKR	VSSOP	DGK	8	2500	330.0	12.4	5.3	3.4	1.4	8.0	12.0	Q1
OPA2388IDGKT	VSSOP	DGK	8	250	330.0	12.4	5.25	3.35	1.25	8.0	12.0	Q1
OPA2388IDGKT	VSSOP	DGK	8	250	330.0	12.4	5.3	3.4	1.4	8.0	12.0	Q1
OPA2388IDR	SOIC	D	8	2500	330.0	12.8	6.4	5.2	2.1	8.0	12.0	Q1
OPA388IDBVR	SOT-23	DBV	5	3000	180.0	8.4	3.23	3.17	1.37	4.0	8.0	Q3
OPA388IDBVT	SOT-23	DBV	5	250	180.0	8.4	3.23	3.17	1.37	4.0	8.0	Q3
OPA388IDBVTG4	SOT-23	DBV	5	250	180.0	8.4	3.23	3.17	1.37	4.0	8.0	Q3
OPA388IDGKR	VSSOP	DGK	8	2500	330.0	12.4	5.3	3.4	1.4	8.0	12.0	Q1
OPA388IDGKT	VSSOP	DGK	8	250	330.0	12.4	5.3	3.4	1.4	8.0	12.0	Q1
OPA388IDR	SOIC	D	8	2500	330.0	12.4	6.4	5.2	2.1	8.0	12.0	Q1
OPA388IDRG4	SOIC	D	8	2500	330.0	12.4	6.4	5.2	2.1	8.0	12.0	Q1
OPA4388IDR	SOIC	D	14	2500	330.0	16.4	6.5	9.0	2.1	8.0	16.0	Q1
OPA4388IPWR	TSSOP	PW	14	2000	330.0	12.4	6.9	5.6	1.6	8.0	12.0	Q1

TAPE AND REEL BOX DIMENSIONS



*All dimensions are nominal

Device	Package Type	Package Drawing	Pins	SPQ	Length (mm)	Width (mm)	Height (mm)
OPA2388IDGKR	VSSOP	DGK	8	2500	366.0	364.0	50.0
OPA2388IDGKR	VSSOP	DGK	8	2500	353.0	353.0	32.0
OPA2388IDGKT	VSSOP	DGK	8	250	366.0	364.0	50.0
OPA2388IDGKT	VSSOP	DGK	8	250	353.0	353.0	32.0
OPA2388IDR	SOIC	D	8	2500	366.0	364.0	50.0
OPA388IDBVR	SOT-23	DBV	5	3000	213.0	191.0	35.0
OPA388IDBVT	SOT-23	DBV	5	250	213.0	191.0	35.0
OPA388IDBVTG4	SOT-23	DBV	5	250	213.0	191.0	35.0
OPA388IDGKR	VSSOP	DGK	8	2500	366.0	364.0	50.0
OPA388IDGKT	VSSOP	DGK	8	250	366.0	364.0	50.0
OPA388IDR	SOIC	D	8	2500	353.0	353.0	32.0
OPA388IDRG4	SOIC	D	8	2500	353.0	353.0	32.0
OPA4388IDR	SOIC	D	14	2500	353.0	353.0	32.0
OPA4388IPWR	TSSOP	PW	14	2000	353.0	353.0	32.0

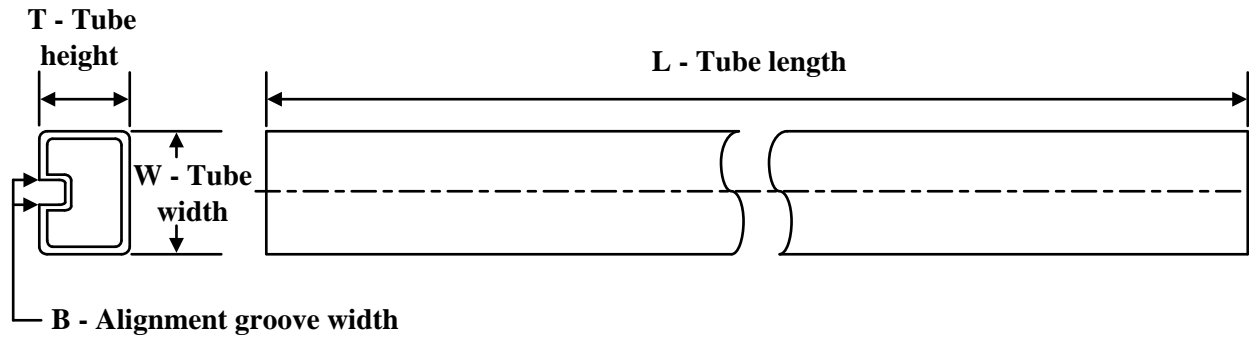
TUBE

*All dimensions are nominal

Device	Package Name	Package Type	Pins	SPQ	L (mm)	W (mm)	T (μm)	B (mm)
OPA2388ID	D	SOIC	8	75	517	7.87	635	4.25
OPA2388ID.B	D	SOIC	8	75	517	7.87	635	4.25
OPA388ID	D	SOIC	8	75	506.6	8	3940	4.32
OPA388ID.B	D	SOIC	8	75	506.6	8	3940	4.32
OPA4388ID	D	SOIC	14	50	506.6	8	3940	4.32
OPA4388ID.B	D	SOIC	14	50	506.6	8	3940	4.32
OPA4388IPW	PW	TSSOP	14	90	530	10.2	3600	3.5
OPA4388IPW.B	PW	TSSOP	14	90	530	10.2	3600	3.5