

Bluetooth, Wi-Fi and Coexistence Mastered in Handheld Devices

By Matthew B. Shoemake, Texas Instruments

Bluetooth and Wi-Fi coexistence has found its quintessential form factor, and it is small enough to fit in the palm of your hand. For years companies and standards bodies have worked on making Wi-Fi (IEEE 802.11b) and Bluetooth (IEEE 802.15.1) coexist, because there was a fear that these devices would generate catastrophic interference with one another. Although the concern was justified, the reality was that very little agony occurred in solving this problem. The usage scenarios and proximities of devices resulting in detectable performance degradation on either network were few and far in between.



As Bluetooth and Wi-Fi begin to take their rightful places in the world, Bluetooth as a Wireless Personal Area Network (WPAN) technology and Wi-Fi as a Wireless Local Area Networking (WLAN) technology, the situation has started to change. Wi-Fi has become the network of choice for wireless Internet connectivity in offices, homes and public hot spots. Bluetooth has become the network of choice for cable replacement enabling wireless voice headsets, keyboards and mice. These logical applications of Wi-Fi and Bluetooth technologies are leading to the natural convergence of the two into handheld devices such as PDAs and smartphones.

With the migration of these two wireless networking technologies into handheld devices, the coexistence of the two can no longer be achieved by depending on distance or limited usage models. In fact, there are key applications that will require both networks to operate simultaneously. Fortunately, solutions exist to enable simultaneous operation of these two networks when embedded in the same device.

Keying in on the problem

Both Wi-Fi and Bluetooth operate in the unlicensed 2.4 GHz industrial, scientific and medical (ISM) band. This band is 83.5 MHz wide, beginning at 2.4 GHz and ending at 2.4835 GHz. Because Wi-Fi and Bluetooth approach spectrum use in different ways, they can cause considerable interference for one another.

Wi-Fi uses wideband stationary signals that use direct sequence spread spectrum (DSSS), single tone modulation, such as CCK (complementary code keying) and PBCC (packet binary convolutional coding), and now OFDM (orthogonal frequency division multiplexing) as added in the new IEEE 802.11g standard. Bluetooth uses a frequency-hopping spread-spectrum (FHSS) technique. While Wi-Fi devices occupy about one quarter of the 83.5 MHz available, Bluetooth devices hop across almost the entire band with an instantaneous bandwidth of about 1 MHz.

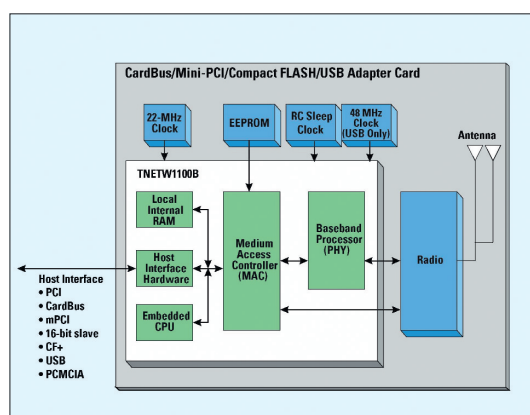

Wi-Fi Block Diagram

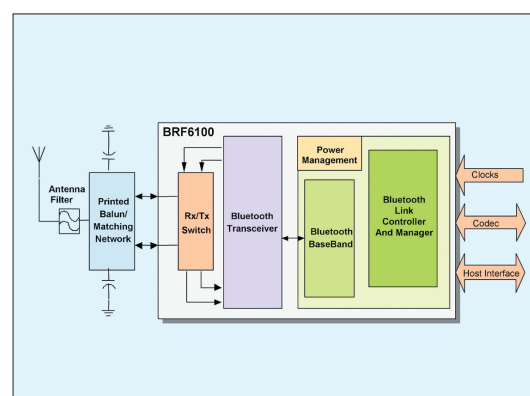

Bluetooth Block Diagram

Distance between Wi-Fi and Bluetooth tends to prevent them from interfering, but in a PDA this is not possible. When Bluetooth and Wi-Fi are put into the same device, the transmitted

signals from one network appear on the receiver of the other making them interfere with the each other. When one transmits while the other is receiving, it is nearly impossible to decode the incoming message, which can cause network connections to drop if left unmitigated.

The problem is similar to a room full of people talking. There may be a lot of noise in the room from all of the conversations, but as long as people are spread out and not too loud, two people in reasonable proximity can hear one another and successfully carry on a conversation. However, if one individual were to decide to talk loudly right next to your ear, you would find it very difficult to continue a conversation with someone else.

Achieving coexistence

To alleviate the general coexistence problem, various solutions have been considered including Adaptive Frequency Hopping (AFH), Transmit Power Control (TPC) and Time Division Multiplexing (TDM). Using these mechanisms in whole are in part enables Bluetooth and Wi-Fi to enjoy simultaneous operation in handheld devices.

Adaptive frequency hopping, while not on the market today, allows Bluetooth and Wi-Fi networks to share frequency. When using AFH the Bluetooth device no longer hops across the whole band, but restricts its hop channels to those frequencies not occupied by the Wi-Fi network. TDM techniques allow for both Bluetooth and Wi-Fi to provide simultaneous operation. And last but not least, each network can use TPC to lessen the degree of interference it generates.

Returning the room full of people talking and one rather loud individual near your ear, there is an analogy for each of the coexistence techniques mentioned above. If you were able to politely ask the loud individual to speak at a higher frequency that you could not hear, you would not care how loud he was talking. This is analogous to AFH. Likewise, if you could reach an agreement whereby the loud individual traded time speaking with you so you could still carry on another conversation, is analogous to TDM. And if you could ask the individual to lower his volume when near your ear, you could also continue your conversation without interruption, which is analogous to TPC.

Reaching the goal

In handheld devices with Bluetooth and Wi-Fi, coexistence can be achieved by using the mechanisms described above. In practice, Bluetooth and Wi-Fi devices must be designed in conjunction with each other to make sure they have the required degree of interference rejection. In addition they must be able to communicate with one another to enable mechanisms such as TDM and AFH.

Bluetooth and WLAN block diagrams are shown in Figures 1 and 2, respectively. In coexistence enabled solutions, collaborative coexistence mechanisms are typically enabled by communication between the Wi-Fi Media Access Controller (MAC) and the Bluetooth link manager. Texas Instruments has designed its Bluetooth and Wi-Fi solutions to allow the use of

coexistence mechanisms and enable simultaneous operation for the next generation of handheld communications devices. All this to ensure that the first time you use your PDA to carry on a VoIP phone call over your Wi-Fi connection that is bridged to your Bluetooth wireless headset your call will maintain high quality due to design for coexistence.

TEXAS INSTRUMENTS,

Tel+1-214-4807976 • Fax+1-214-4803386

enter 3001 at
www.epn-online.com