



TEXAS INSTRUMENTS

TI DN 2510510 Rev A
May 2009

DLP® Pico MAIN-B SCHEMATIC

IMPORTANT NOTICE

BEFORE USING TECHNICAL INFORMATION, THE USER SHOULD CAREFULLY READ THE FOLLOWING TERMS.

The term "Technical Information" includes reference designs, drawings, specifications, and other information relating to TI DLP® products or applications, contained herein or provided separately in any format or via any medium.

TI is providing Technical Information for the convenience of purchasers of DLP® products ("Users"), and will not accept any responsibility or liability arising from providing the Technical Information or its use. Any use or reliance on Technical Information is strictly the responsibility of the User.

1. **No Warranty.** *THE TECHNICAL INFORMATION IS PROVIDED "AS IS"*. TI MAKES NO WARRANTIES OR REPRESENTATIONS, EXPRESS, IMPLIED OR STATUTORY, INCLUDING LACK OF VIRUSES, ACCURACY, OR COMPLETENESS. TI DISCLAIMS ANY WARRANTY OF TITLE, ANY IMPLIED WARRANTIES OF MERCHANTABILITY, FITNESS FOR A PARTICULAR PURPOSE, QUIET ENJOYMENT, QUIET POSSESSION, AND NON-INFRINGEMENT OF ANY THIRD PARTY INTELLECTUAL PROPERTY RIGHTS WITH REGARD TO THE TECHNICAL INFORMATION OR THE USE OF THOSE MATERIALS.
2. **Warranty for Products Not Affected.** The foregoing exclusion and disclaimer of warranty does not affect or diminish any warranty rights with regard to DLP® products. Such rights are governed exclusively by the terms of a written and signed purchase agreement with TI.
3. **Limitations and Exclusion of Damages.** IN NO EVENT SHALL TI BE LIABLE FOR ANY ACTUAL, SPECIAL, INCIDENTAL, CONSEQUENTIAL OR INDIRECT DAMAGES, HOWEVER CAUSED, ON ANY THEORY OF LIABILITY AND WHETHER OR NOT TI HAS BEEN ADVISED OF THE POSSIBILITY OF SUCH DAMAGES, ARISING IN ANY WAY OUT OF THE TECHNICAL INFORMATION OR THE USE OF THE TECHNICAL INFORMATION.
4. **No Engineering Services.** User is fully responsible for all design decisions and engineering with regard to its products, including decisions relating to application of DLP® products. By providing Technical Information TI does not intend to offer or provide engineering services or advice concerning User's design. If User desires engineering services, then User should rely on its retained employees and consultants and/or procure engineering services from a licensed professional engineer ("LPE").
5. **Compliance with Export Control Laws.** Unless prior authorization is obtained from the U.S. Department of Commerce, User may not export, re-export, or release, directly or indirectly, any Technical Information, or export, directly or indirectly, any direct product of such Technical Information to any destination or country to which the export, re-export or release of the Technical Information or direct product is prohibited by the Export Administration Regulations of the U.S. Department of Commerce ("EAR").

Reference

1. DLP® Pico Kit Functional Guide, TI drawing number 2510476
2. DLP® Pico Chipset Interface Manual, TI drawing number 2510477
3. DLP® Pico DVI-B SCHEMATIC, TI drawing number 2510511
4. DLP® Pico DMD-B SCHEMATIC, TI drawing number 2510512
5. DLP® Pico Geber MAIN BOARD, TI drawing number 2510513
6. DLP® Pico Geber DVI BOARD, TI drawing number 2510514
7. DLP® Pico Geber DMD CONTROL BOARD, TI drawing number 2510515

DLP® Pico Kit main board schematic

For a reference of the DLP® Pico Kit main board schematic see the design file, ***TI2510510_L9502G001_MAIN-B_SCHEMATIC_D02_12222008.DSN***. This file contains the schematic information for the Pico Kit main board.

How do I get the design file?

The design file for the DLP® Pico Kit main board schematic is available to you through an authorized DLP® Discovery™ value-added reseller (VAR). A list of the VARs can be found at: www.dlpdiscovery.com/var. Please reference the file name above when contacting a VAR.

Content :

P01_Content

P02_Block_Diagram

P03_FPGA_I/O_1

P04_FPGA_I/O_2

P05_FPGA_Power&Memory

P06_External_Connector

P07_DMD_REG

P08_I2C_Level_Shift

P09_MCU

P10_Power



YOUNG Optics			PCBA P/N: 80.L9502G001	PCBA Rev 8
			PCB P/N: 00.L9502G001	PCB Rev 0
Approver	Designer	Draw er	Title	
Daniel	Larry	Larry	Content	
			Size C	Rev A
			Document Number END	
			Date: Tuesday, March 31, 2009	Sheet 1 of 10
<small>01-04-008TLP1 Ver. A</small>				

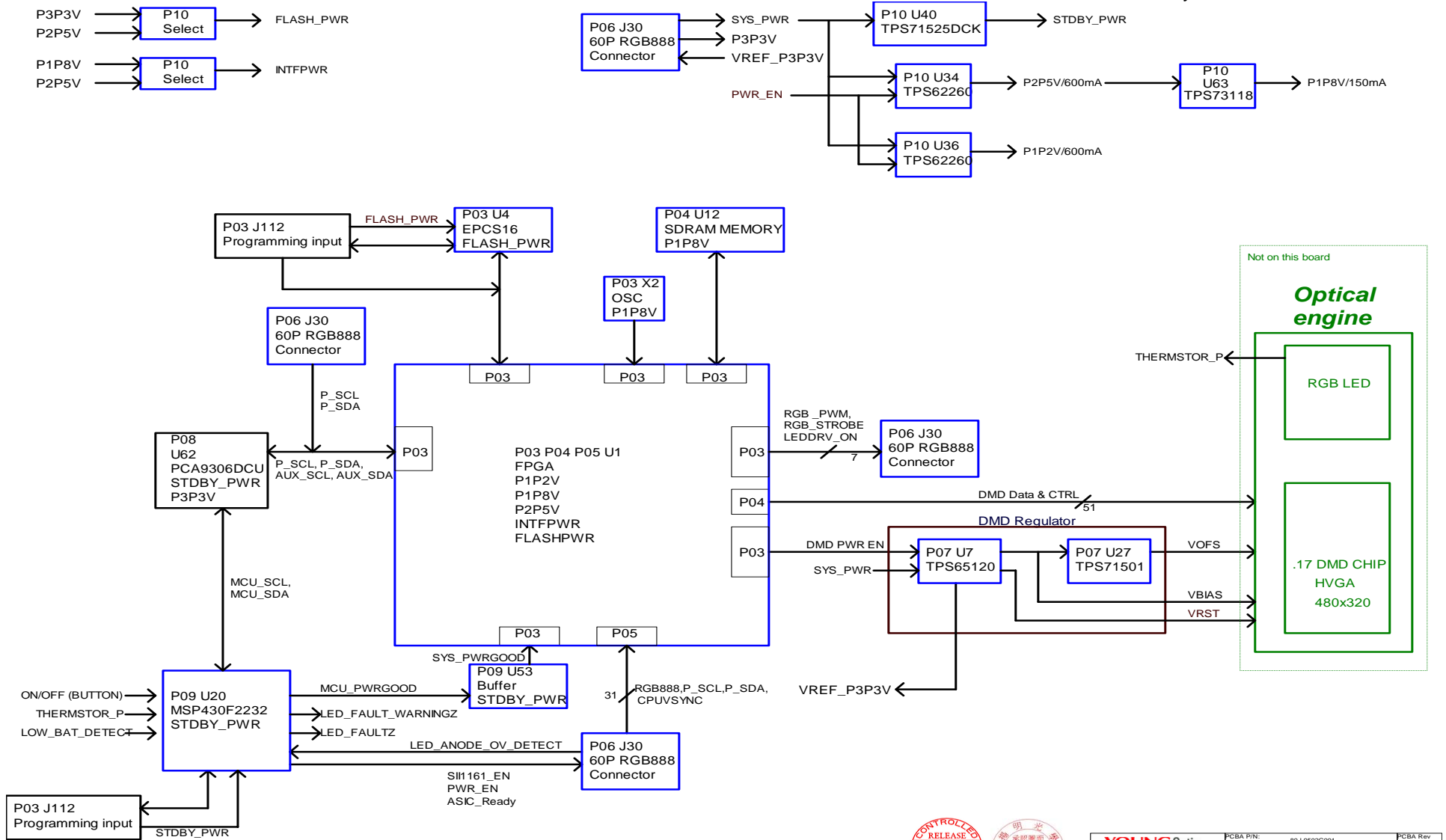

YOUNG Optics			PCBA P/N:	80 L9602G001	PCBA Rev:
			PCB P/N:	00 L9602G001	PCB Rev:
Approver:	Designer:	Draw er:	Title:		
Daniel	Larry	Larry	Block Diagram		
			Size:	Plotting Number:	Rev:
			C:	PLD	A
			Date:	Issue Date:	Sheet:
				2009, May 13, 2009	2 of 10

01-04-098TLF1 Ver. A

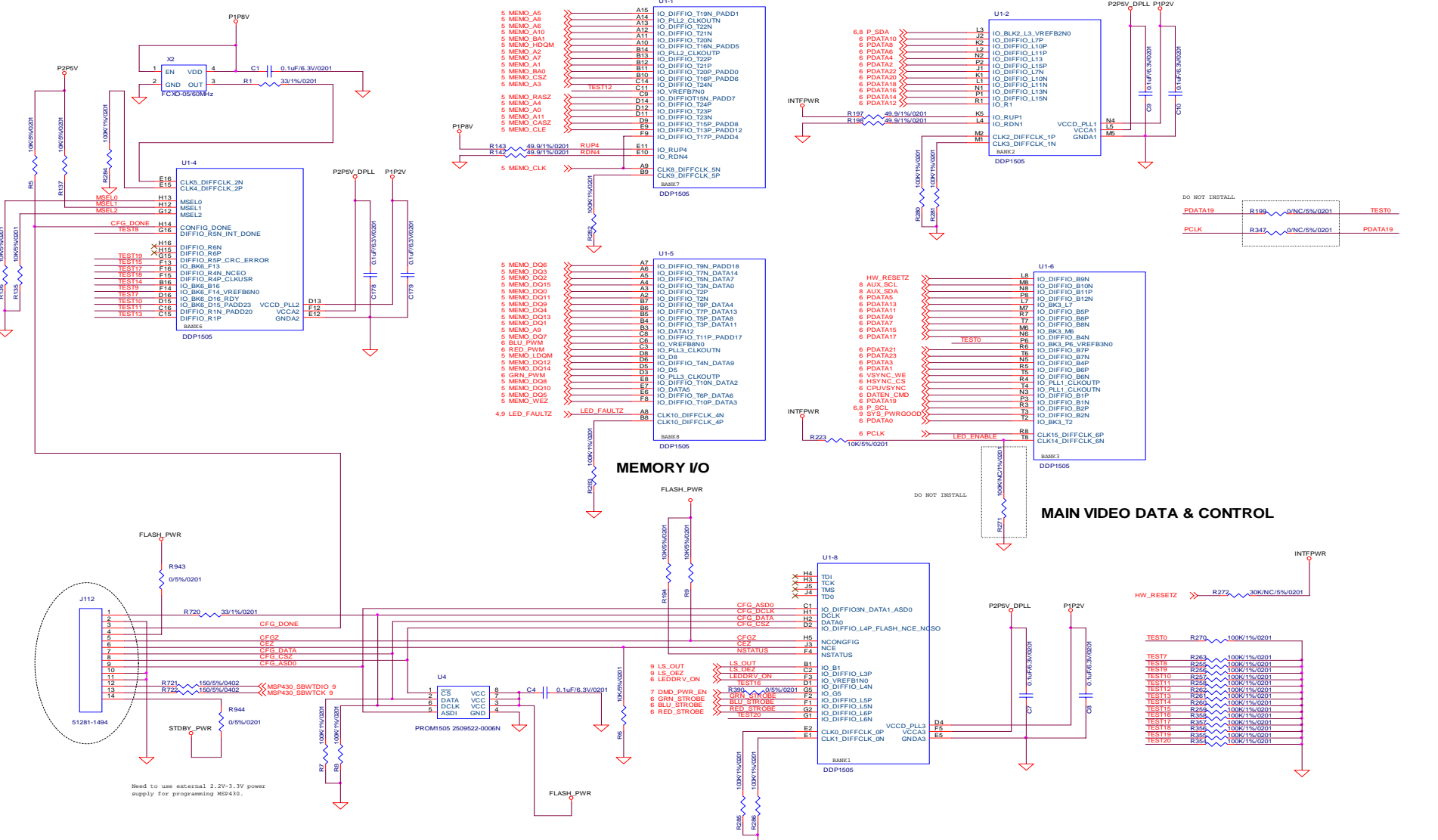

Need to use external 0.2V-3.3V power supply for programming MSP430.



YOUNG Optics			PCBA P/N:	80.L9502G001	PCBA Rev:	B
			PCB P/N:	00.L9502G001	PCB Rev:	0
Approver:	Designer:	Draw er:	Title:	FPGA U/I-1/2	Rev:	A
Daniel	Larry	Larry	Size:	Document Number	File:	0
			Date:	Tuesday, May 19, 2009	Sheet:	3 of 10
			01-04-U015111-1 Ver. A			

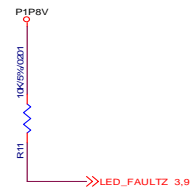
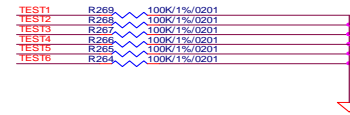
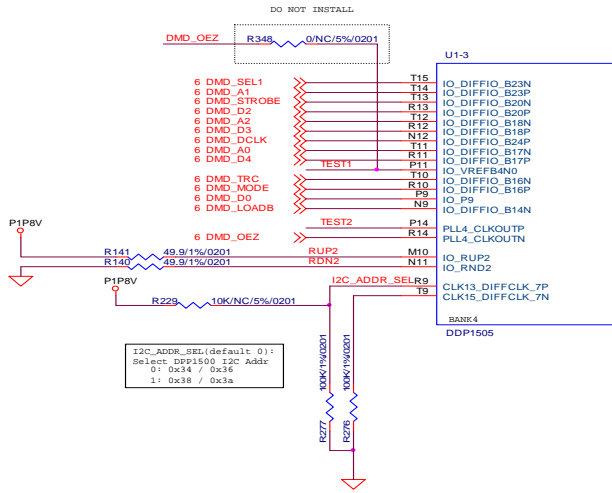

If U51 is not installed
LED_FAULTZ must be pulled
up at the DPP1500 input.

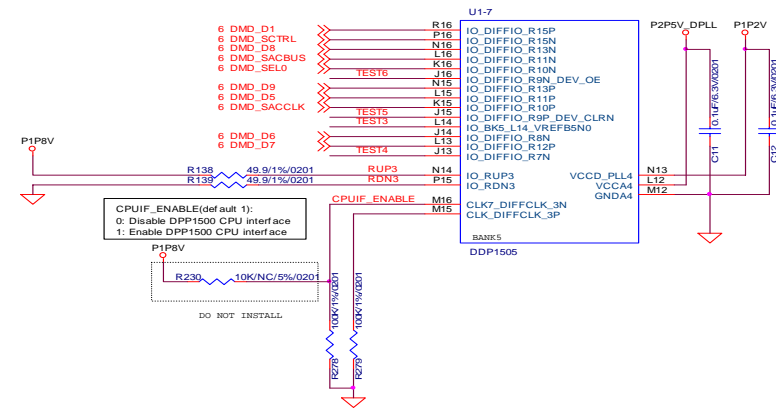

DMD I/O



YOUNG Optics			PCBA P/N: 80.L9502G001	PCBA Rev 8
			PCB P/N: 00.L9502G001	PCB Rev D
Approver	Designer	Draw er	Title	
Daniel	Larry	Larry	FPGA I/O 2/2	
Size	Document Number	Rev	A	
C	FLD			
Date: Tuesday, March 31, 2009	Sheet 4 of 10			
01-04-00BTLF1 Ver.A				

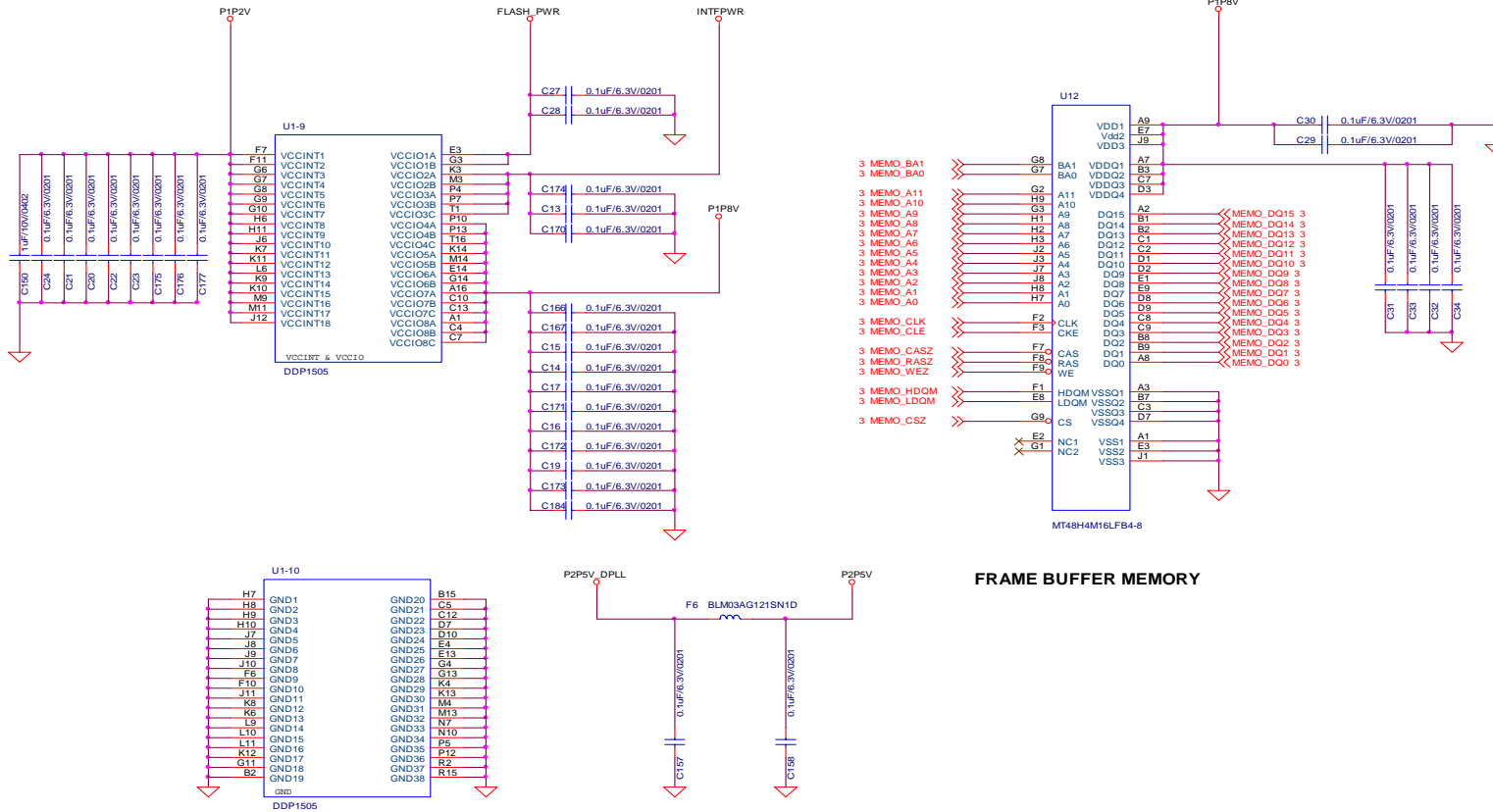

YOUNG Optics			PCBA P/N: 80.L9502G001	PCBA Rev B
			PCB P/N: 00.L9502G001	PCB Rev D
Approver	Designer	Drawer	Title: FPGA Power & Memory	
Daniel	Larry	Larry	Size: Document Number	Rev: A
			Date: Tuesday, March 31, 2009	Sheet 5 of 10

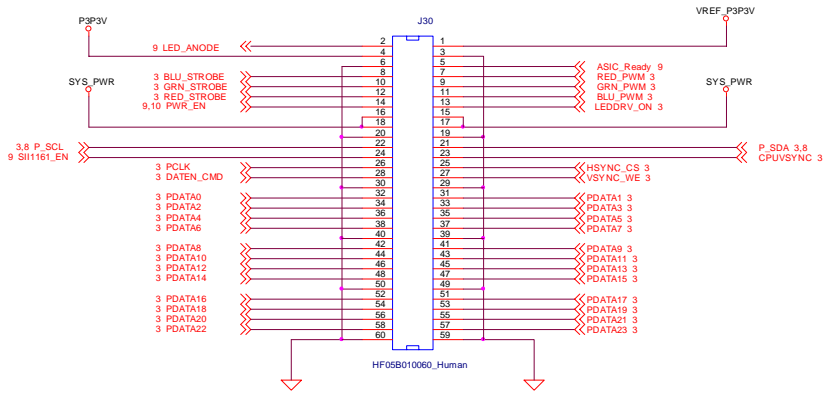

VIDEO CONNECTION

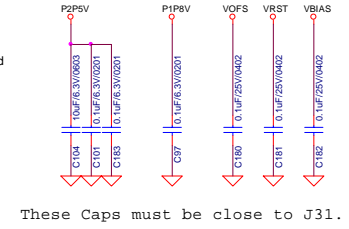
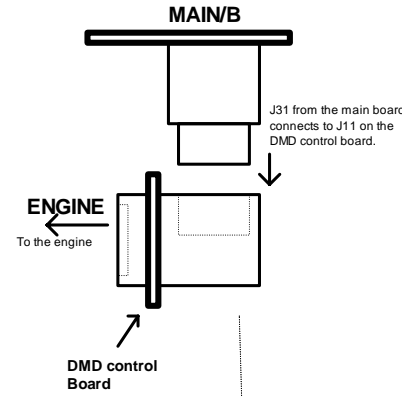

These Caps must be close to J31.

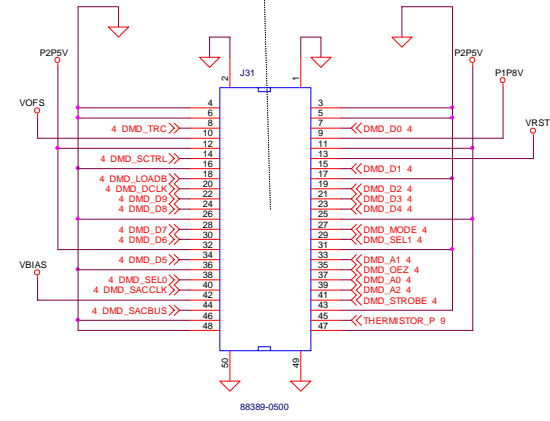

To DMD



YOUNG Optics			PCBA P/N: 80.L9502G001	PCBA Rev B
			PCB P/N: 00.L9502G001	PCB Rev D
Approver	Designer	Draw er	Title: External Connector	
Daniel	Larry	Larry	Size: Document Number	
			Date: Tuesday, May 19, 2009	
			Sheet 6 of 10	
			01-04-0081P1 Ver A	

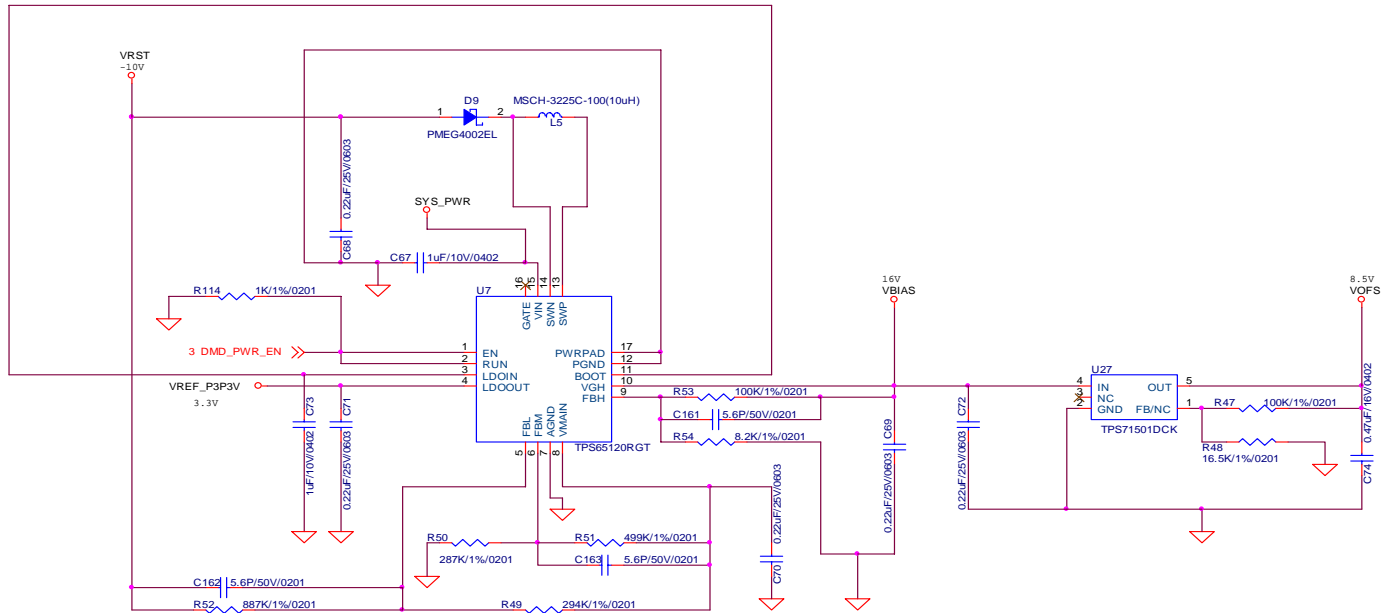

YOUNG Optics			PCBA P/N:	80.L9502G001	PCBA Rev	B
			PCB P/N:	00.L9502G001	PCB Rev	D
Approver	Designer	Draw er	Title			
Daniel	Larry	Larry	DMD REG			
Size	Document Number				Rev	
C	FLD				A	
Date: Tuesday, March 31, 2009					Sheet	7 of 10
					01-04-0081L01 Ver. A	

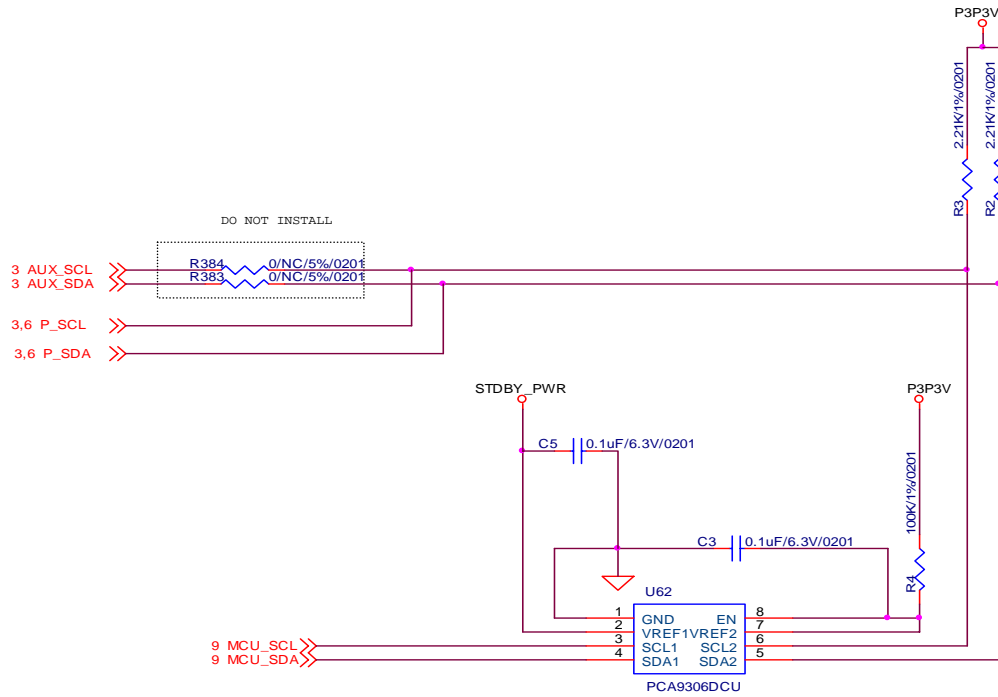

YOUNG Optics			PCBA P/N:	80.L9502G001	PCBA Rev	B
			PCB P/N:	00.L9502G001	PCB Rev	D
Approver	Designer	Drawer	Title			
Daniel	Larry	Larry	I2C Level Shift			
Size	Document Number				Rev	A
C	FLD					
Date:	Tuesday, March 31, 2009	Sheet			8	of 10
OI-04-008TLF1 Ver .A						

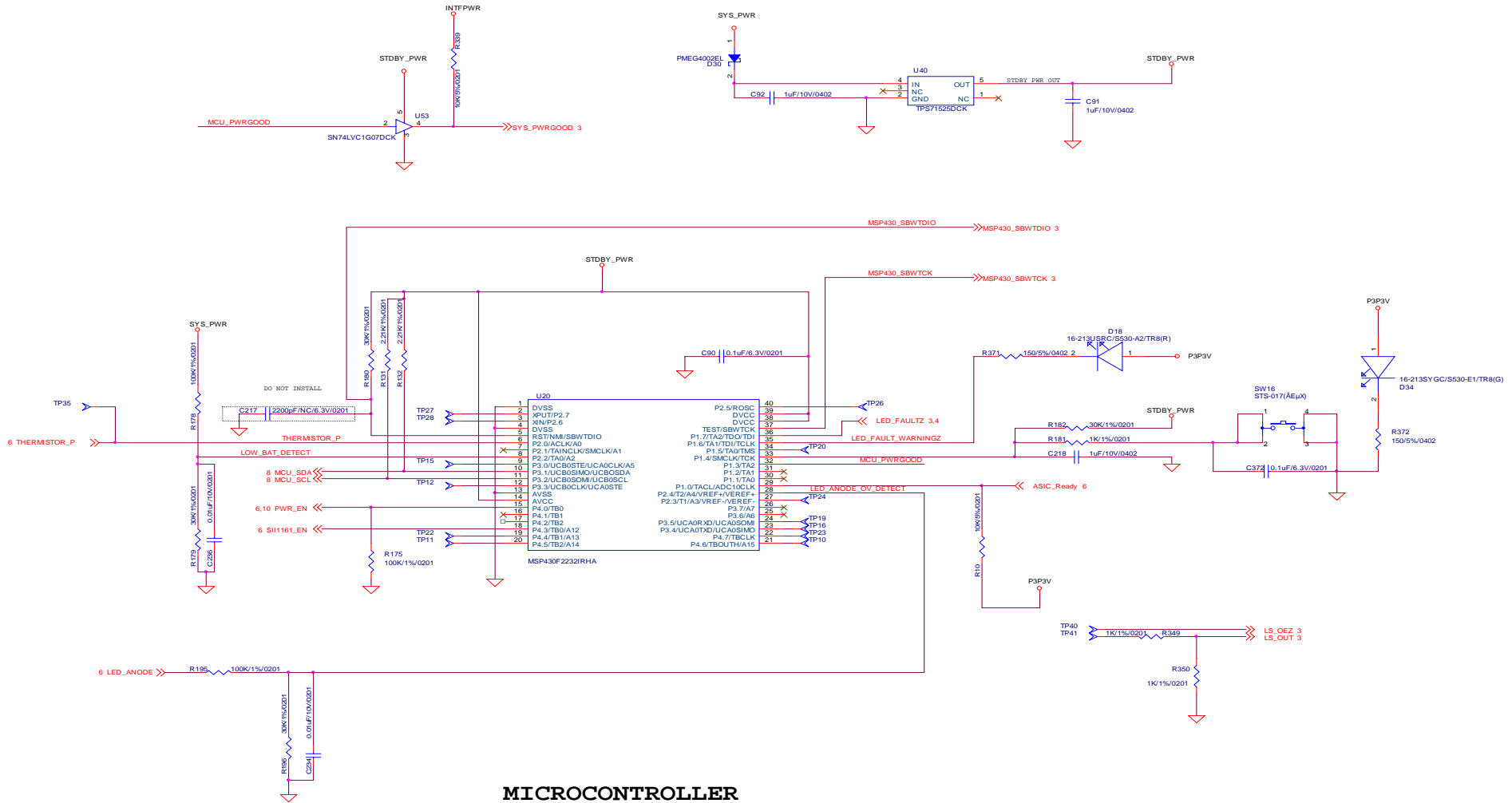

MICROCONTROLLER



YOUNG Optics			PCBA P/N: 80.L9502G001	PCBA Rev B
Approver	Designer	Draw er	PCB P/N: 00.L9502G001	PCB Rev D
Daniel	Larry	Larry	Title: MCU	Rev A
Size: C	Document Number: ELD	Date: Tuesday, March 31, 2009	Sheet 9 of 10	Rev A

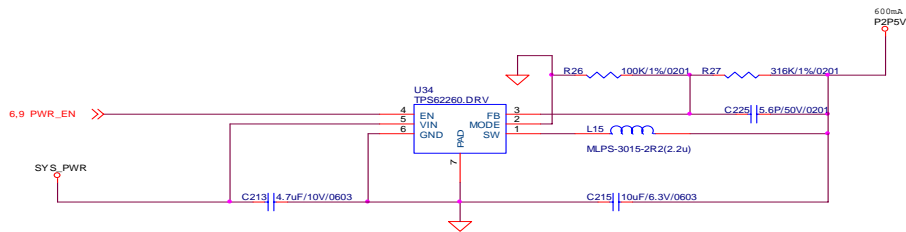
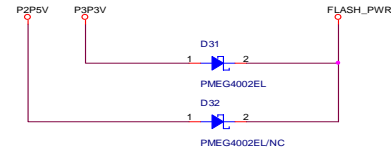
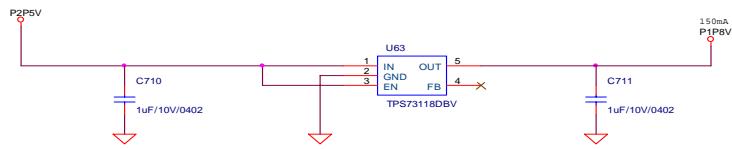
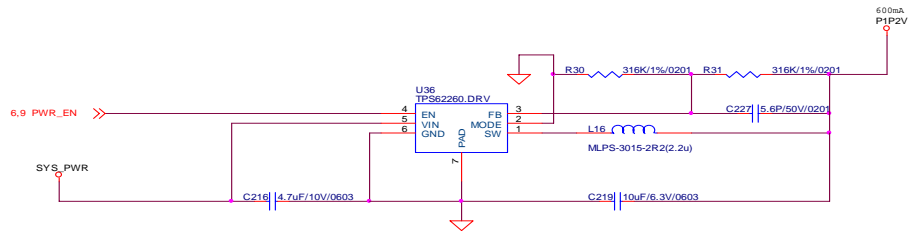

YOUNG Optics			PCBA P/N:	80.L9502G001	PCBA Rev	B
Approver	Designer	Drawer	PCB P/N:	00.L9502G001	PCB Rev	D
Daniel	Larry	Larry	Title	Power	Rev	A
			Size	Document Number	FLD	
			Date:	Tuesday, March 31, 2009	Sheet	10 of 10
						01-04-008TUF1 Ver. A