

Legal Disclaimer:

TI's publication of information regarding third-party products or services does not constitute an endorsement regarding the suitability of such products or services or a warranty, representation or endorsement of such products or services, either alone or in combination with any TI product or service.

Space Micro Inc.

Single Event Effects Solutions For VLIW Microprocessors 2004

Contact: David Czajkowski
(858) 487-9295
dcz@spacemicro.com
www.spacemicro.com



Microprocessors Problems SEU & SEFI

PowerPC SEU Rate

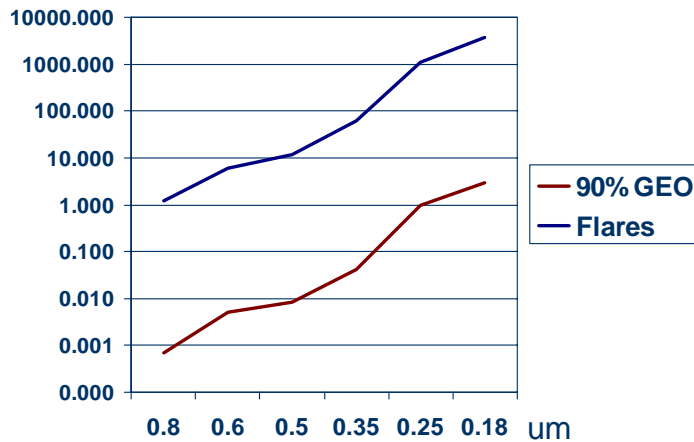

- SEU rate getting worse
 - Trend from 0.8 to 0.18 um

• SEFI (Single Event Functional Interrupts... aka "Hangs")

- Processor hangs by SEU
- By protons or heavy ions
- All CPUs are susceptible
- Approx. rate 1 every 100 days – SOI PPC (10x for CMOS)
- **SEFI problem is Severe & not easily solvable**
 - Power down is current industry solution

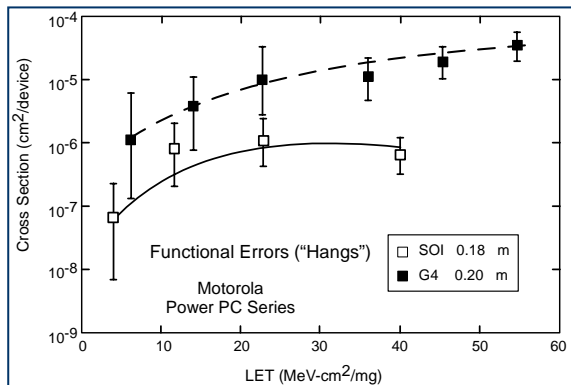

PowerPC SEFI Data



SEU Correcting Technology: Time-Triple Modular Redundancy

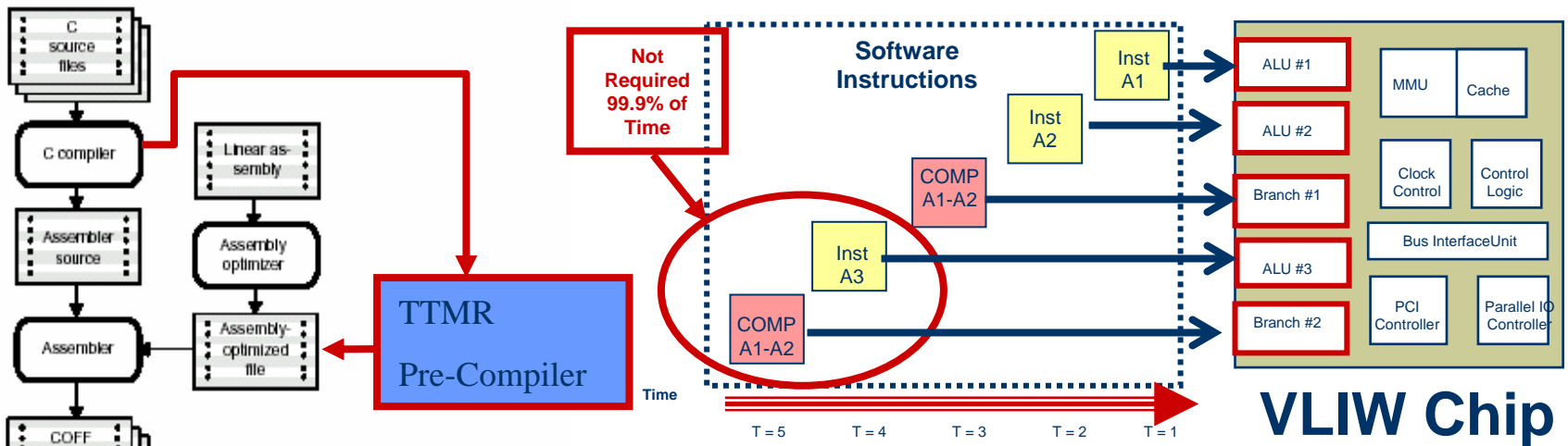

Single DSP solution!

Software

- ◆ TTMR™ Combines Time & Spatial redundancy
- ◆ Takes advantage of VLIW parallel opportunities
- ◆ SEU error rate expected to be equal to TMR
- ◆ Software controllable, selectable performance
 - High speed worse SEU rate
 - 50% speed better SEU rate
- SEFI is NOT fixed with TTMR...see H-Core
- Proton radiation tested



SEFI Solved with Hardened Core: H-Core is More Than a Chip!

- Timer code when NO SEFI
- KILL Threads post SEFI
- Read H-Core Status Flags
- Flush cache & registers
- Recovery routines
- Rollback software routines

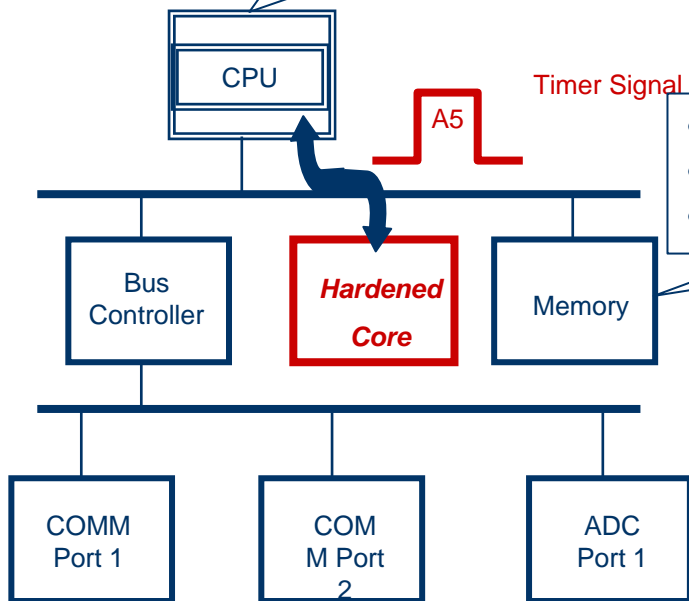

- Rollback data stored in Memory
- Store critical variable periodically
- Store instruction pointer locations

- ◆ Tested at UC Davis with 51 MeV Protons
- ◆ Test CPU was Pentium III, Intel, 850 MHz
- ◆ Summary Results:
 - 21 SEFIs induced
 - 21 recoveries by SEFI Watchdog Functions
 - IRQ, NMI and Reset brought back Pentium III
- ◆ *** Patent Pending ***
- ◆ **RESULT: SEFI Watchdog Proven with Protons**

- ◆ Software + hardware
- ◆ Software allows for post SEFI Recovery