

Lithium Ion Fast-Charge IC

Features

- ▶ Safe charge of Lithium Ion battery packs
- ▶ Voltage-regulated current-limited charging
- ▶ Fast charge terminated by selectable minimum current; safety backup termination on maximum time
- ▶ Charging continuously qualified by temperature and voltage limits
- ▶ Pulse-width modulation control ideal for high-efficiency switch-mode power conversion
- ▶ Direct LED control outputs display charge status and fault conditions

General Description

The bq2054 Lithium Ion Fast-Charge IC is designed to optimize charging of lithium ion (Li-Ion) chemistry batteries. A flexible pulse-width modulation regulator allows the bq2054 to control voltage and current during charging. The regulator frequency is set by an external capacitor for design flexibility. The switch-mode design keeps power dissipation to a minimum.

The bq2054 measures battery temperature using an external thermistor for charge qualification. Charging begins when power is applied or on battery insertion.

For safety, the bq2054 inhibits charging until the battery voltage and temperature are within con-

figured limits. If the battery voltage is less than the low-voltage threshold, the bq2054 provides low-current conditioning of the battery.

A constant current-charging phase replenishes up to 70% of the charge capacity, and a voltage-regulated phase returns the battery to full. The charge cycle terminates when the charging current falls below a user-selectable current limit. For safety, charging terminates after maximum time and is suspended if the temperature is outside the preconfigured limits.

The bq2054 provides status indications of all charger states and faults for accurate determination of the battery and charge system conditions.

Pin Connections

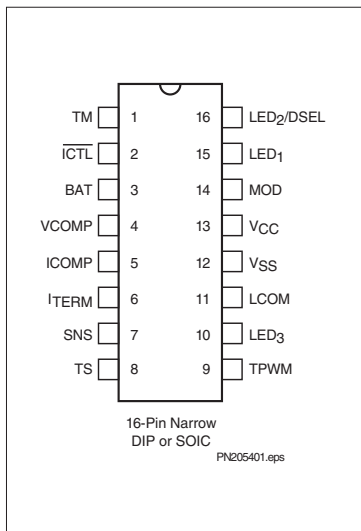

Pin Names

TM	Time-out programming input	TPWM	Regulator timebase input
$\overline{\text{ICTL}}$	Inrush current control output	LED ₃	Charge status output 3
BAT	Battery voltage input	LCOM	Common LED output
VCOMP	Voltage loop comp input	V _{SS}	System ground
ICOMP	Current loop comp input	V _{CC}	5.0V±10% power
ITERM	Minimum current termination select input	MOD	Modulation control output
SNS	Sense resistor input	LED ₁	Charge status output 1
TS	Temperature sense input	LED ₂ /DSEL	Charge status output 2/Display select input

Pin Descriptions

TM Time-out programming input

This input sets the maximum charge time. The resistor and capacitor values are determined using Equation 5. Figure 7 shows the resistor/capacitor connection.

ICTL Inrush current control output

ICTL is driven low during the fault or charge-complete states of the chip. It is used to disconnect the capacitor across the battery pack terminals, preventing inrush currents from tripping overcurrent protection features in the pack when a new battery is inserted.

BAT Battery voltage input

BAT is the battery voltage sense input. This potential is generally developed using a high-impedance resistor divider network connected between the positive and the negative terminals of the battery. See Figure 4 and Equation 1.

VCOMP Voltage loop compensation input

This input uses an external R-C network for voltage loop stability.

ITERM Minimum current termination select

This three-state input is used to set I_{MIN} for fast charge termination. See Table 2.

ICOMP Current loop compensation input

This input uses an external R-C network for current loop stability.

SNS Charging current sense input

Battery current is sensed via the voltage developed on this pin by an external sense resistor, R_{SNS} , connected in series with the negative terminal of the battery pack. See Equation 6.

TS Temperature sense input

This input is used to monitor battery temperature. An external resistor divider network sets the lower and upper temperature thresholds. See Figure 6 and Equations 3 and 4.

TPWM Regulation timebase input

This input uses an external timing capacitor to ground to set the pulse-width modulation (PWM) frequency. See Equation 7.

LCOM Common LED output

Common output for LED₁₋₃. This output is in a high-impedance state during initialization to read programming input on DSEL.

MOD Current-switching control output

MOD is a pulse-width modulated push/pull output that is used to control the charging current to the battery. MOD switches high to enable current flow and low to inhibit current flow.

LED₁₋₃ LED₃ Charger display status 1–3 outputs

These charger status output drivers are for the direct drive of the LED display. Display modes are shown in Table 1. These outputs are tri-stated during initialization so that DSEL can be read.

DSEL Display select input

This three-level input controls the LED₁₋₃ charge display modes. See Table 1.

VCC VCC supply

5.0V, $\pm 10\%$ power

VSS Ground

bq2054

Charge Algorithm

The bq2054 uses a two-phase fast charge algorithm. In phase 1, the bq2054 regulates constant current ($I_{SNS} = I_{MAX}$) until $V_{CELL} (= V_{BAT} - V_{SNS})$ rises to V_{REG} . The bq2054 then transitions to phase 2 and regulates constant voltage ($V_{CELL} = V_{REG}$) until the charging current falls below the programmed I_{MIN} threshold. The charging current must remain below I_{MIN} for $120 \pm 40ms$ before a valid fast charge termination is detected. Fast charge then terminates, and the bq2054 enters the Charge Complete state. See Figures 1 and 2.

Charge Qualification

The bq2054 starts a charge cycle when power is applied while a battery is present or when a battery is inserted. Figure 2 shows the state diagram for pre-charge qualification and temperature monitoring. The bq2054 first checks that the battery temperature is within the allowed, user-configurable range. If the temperature is out of range, the bq2054 enters the Charge Pending state and waits until the battery temperature is within the allowed range. Charge Pending is enunciated by LED₃ flashing.

Thermal monitoring continues throughout the charge cycle, and the bq2054 enters the Charge Pending state when the temperature out of range. (There is one exception; if the bq2054 is in the Fault state—see below—the out-of-range temperature is not recognized until the bq2054 leaves the Fault state.) All timers are suspended (but not reset) while the bq2054 is in Charge Pending. When the temperature comes back into range, the bq2054 returns to the point in the charge cycle where the out-of-range temperature was detected.

When the temperature is valid, the bq2054 then regulates current to $I_{COND} (= I_{MAX}/5)$. After an initial holdoff period t_{HO} (which prevents the chip from reacting to transient voltage spikes that may occur when charge current is first applied), the chip begins monitoring V_{CELL} . If V_{CELL} does not rise to at least V_{MIN} before the expiration of time-out limit t_{MTO} (e.g. the cell has failed short), the bq2054 enters the Fault state. If V_{MIN} is achieved before expiration of the time limit, the chip begins fast charging.

Once in the Fault state, the bq2054 waits until V_{CC} is cycled or a new battery insertion is detected. It then starts a new charge cycle and begins the qualification process again.

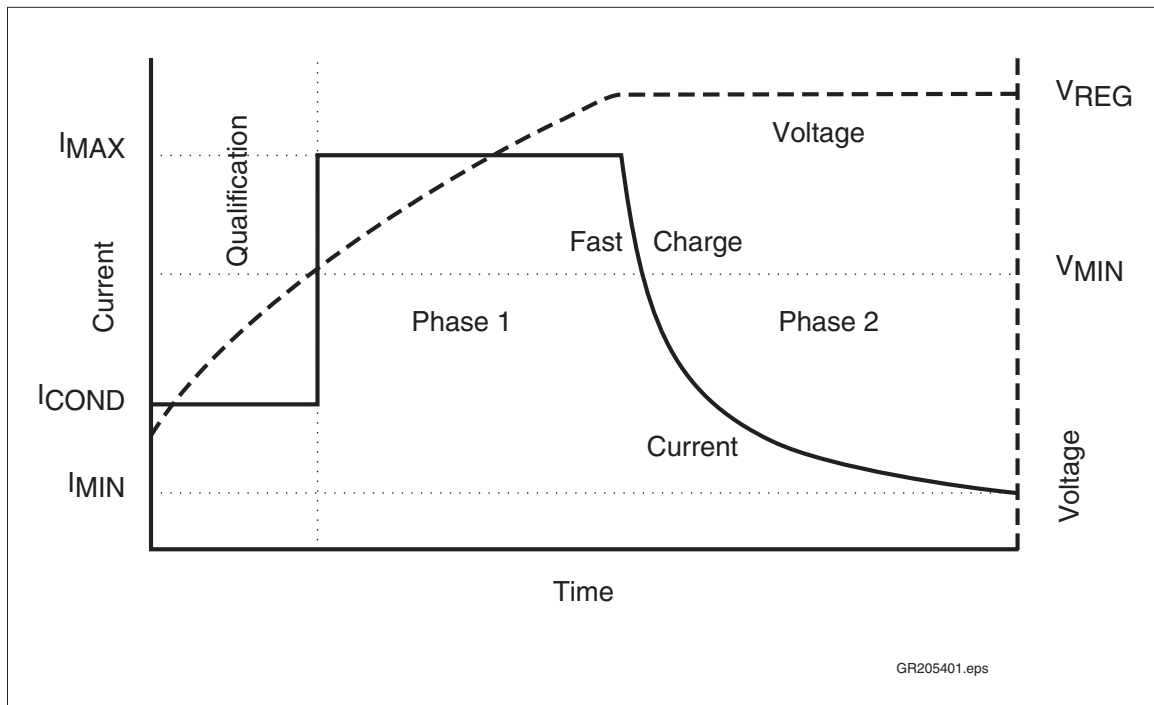

Figure 1. bq2054 Charge Algorithm

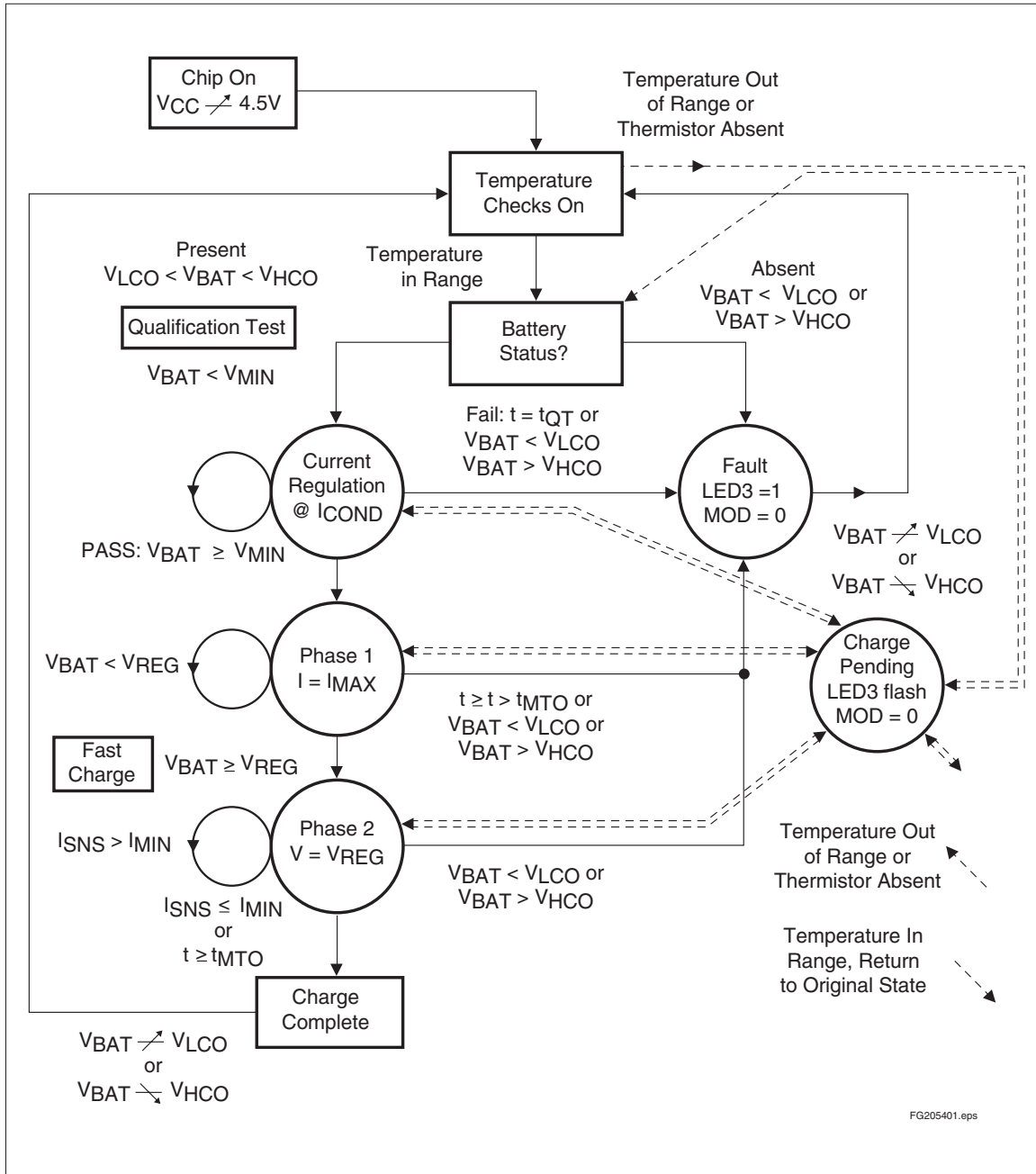

Figure 2. bq2054 State Diagram

bq2054

Charge Status Display

Charge status is enunciated by the LED driver outputs LED₁–LED₃. Three display modes are available in the bq2054; the user selects a display mode by configuring pin DSEL. Table 1 shows the three display modes.

The bq2054 does not distinguish between an over-voltage fault and a “battery absent” condition. The bq2054 enters the Fault state, enunciated by turning on LED₃, whenever the battery is absent. The bq2054, therefore, gives an indication that the charger is on even when no battery is in place to be charged.

Configuring the Display Mode and I_{MIN}

DSEL/LED₂ is a bi-directional pin with two functions; it is an LED driver pin as an output and a programming pin as an input. The selection of pull-up, pull-down, or no pull resistor programs the display mode on DSEL per Table 1. The bq2054 latches the programming data sensed on the DSEL input when any one of the following three events occurs:

1. V_{CC} rises to a valid level.
2. The bq2054 leaves the Fault state.
3. The bq2054 detects battery insertion.

The LEDs go blank for approximately 750ms (typical) while new programming data is latched.

Table 1. bq2054 Display Output Summary

Mode	Charge Action State	LED ₁	LED ₂	LED ₃
DSEL = 0 (Mode 1)	Battery absent or over-voltage fault	Low	Low	High
	Pre-charge qualification	Flash	Low	Low
	Fast charging	High	Low	Low
	Charge complete	Low	High	Low
	Charge pending (temperature out of range)	X	X	Flash
	Charging fault	X	X	High
DSEL = 1 (Mode 2)	Battery absent or over-voltage fault	Low	Low	High
	Pre-charge qualification	High	High	Low
	Fast charge	Low	High	Low
	Charge complete	High	Low	Low
	Charge pending (temperature out of range)	X	X	Flash
	Charging fault	X	X	High
DSEL = Float (Mode 3)	Battery absent or over-voltage fault	Low	Low	High
	Pre-charge qualification	Flash	Flash	Low
	Fast charge: current regulation	Low	High	Low
	Fast charge: voltage regulation	High	High	Low
	Charge complete	High	Low	Low
	Charge pending (temperature out of range)	X	X	Flash
	Charging fault	X	X	High

Note: 1 = V_{CC}; 0 = V_{SS}; X = LED state when fault occurred; Flash = 1/6 sec. low, 1/6 sec high.

Fast charge terminates when the charging current drops below a minimum current threshold programmed by the value of I_{TERM} (see Table 2) and remains below that level for 120 ± 40 ms.

Table 2. I_{MIN} Termination Thresholds

I_{TERM}	I_{MIN}
0	$I_{MAX}/10$
1	$I_{MAX}/20$
Float	$I_{MAX}/30$

Figure 3 shows the bq2054 configured for display mode 2 and $I_{MIN} = I_{MAX}/10$.

Voltage and Current Monitoring

The bq2054 monitors battery pack voltage at the BAT pin. The user must implement a voltage divider between the positive and negative terminals of the battery pack to present a scaled battery pack voltage to the BAT pin. The bq2054 also uses the voltage across a sense resistor (R_{SNS}) between the negative terminal of the battery pack and ground to monitor the current into the pack. See Figure 4 for the configuration of this network.

The resistor values are calculated from the following:

Equation 1

$$\frac{RB1}{RB2} = \frac{N * V_{REG}}{205V} - 1$$

where:

- N = Number of cells in series
- V_{REG} = Desired fast-charging voltage per cell

These parameters are typically specified by the battery manufacturer. The total resistance presented across the battery pack by $RB1 + RB2$ should be between $150k\Omega$ and $1M\Omega$. The minimum value ensures that the divider network does not drain the battery excessively when the power source is disconnected. Exceeding the maximum value increases the noise susceptibility of the BAT pin.

The current sense resistor, R_{SNS} (see Figure 5), determines the fast charge current. The value of R_{SNS} is given by the following:

Equation 2

$$I_{MAX} = \frac{0.250V}{R_{SNS}}$$

where:

- I_{MAX} = Desired maximum charge current

Hold-Off Period

Both V_{HCO} and I_{MIN} terminations are ignored during the first 1.33 ± 0.19 seconds of both the Charge Qualification and Fast Charge phases. This condition prevents premature termination due to voltage spikes that may occur when charge is first applied.

bq2054

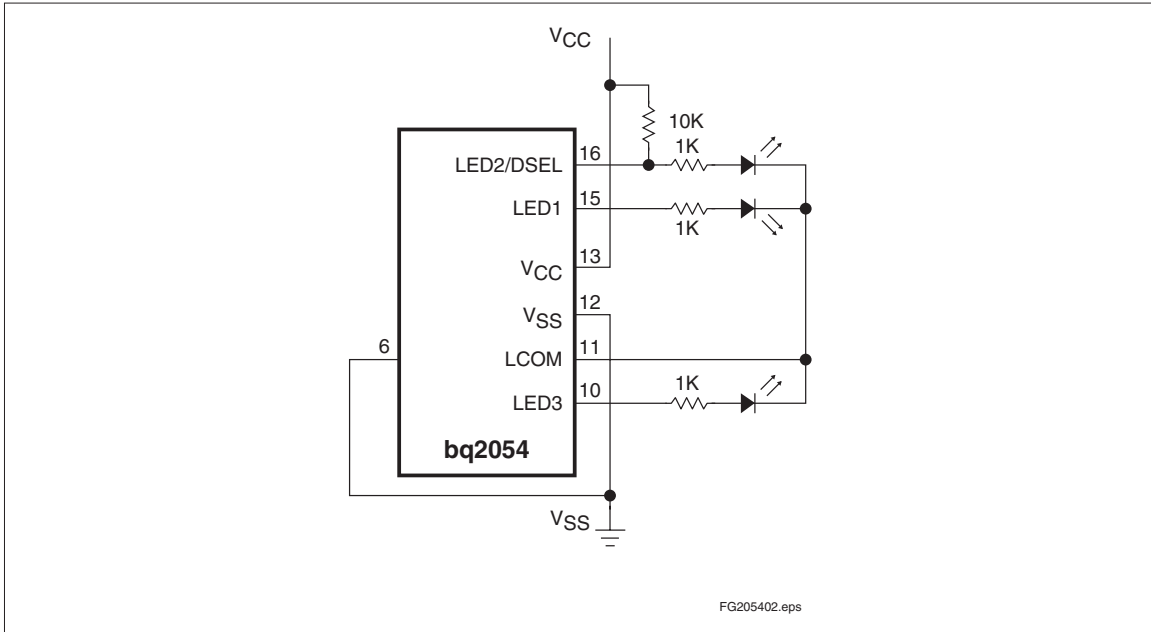

Figure 3. Configured Display Mode/IMIN Threshold

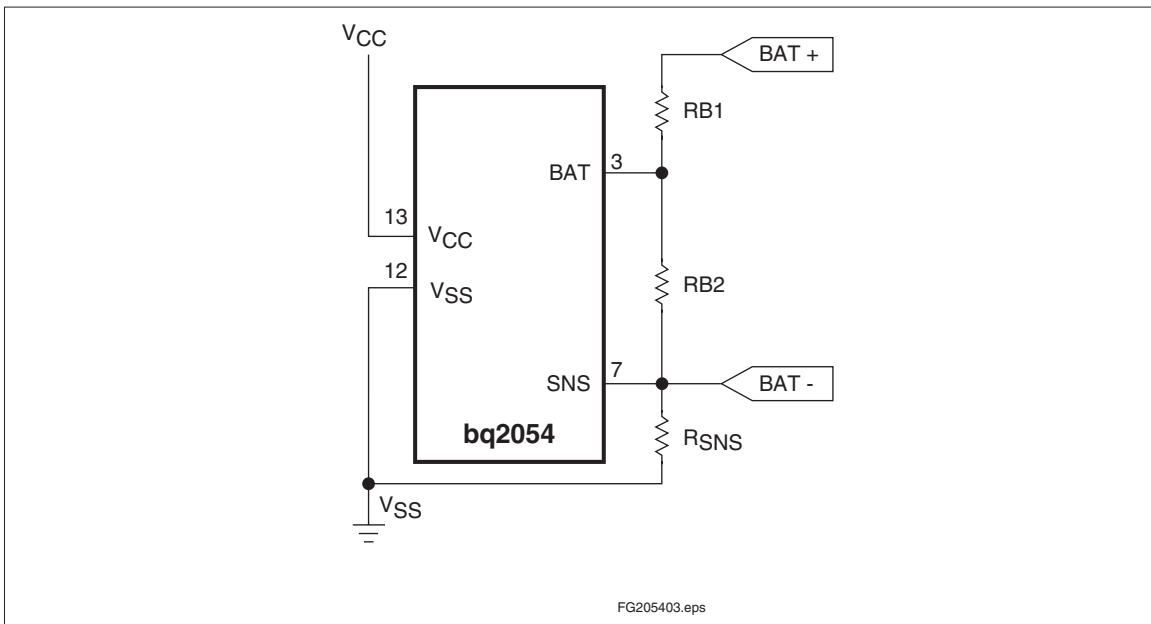

Figure 4. Configuring the Battery Divider

Battery Insertion and Removal

V_{CELL} is interpreted by the bq2054 to detect the presence or absence of a battery. The bq2054 determines that a battery is present when V_{CELL} is between the High-Voltage Cutoff ($V_{HCO} = V_{REG} + 0.25V$) and the Low-Voltage Cutoff ($V_{LCO} = 0.8V$). When V_{CELL} is outside this range, the bq2054 determines that no battery is present and transitions to the Fault state. Transitions into and out of the range between V_{LCO} and V_{HCO} are treated as battery insertions and removals, respectively. The V_{HCO} limit also implicitly serves as an over-voltage charge termination.

Inrush Current Control

Whenever the bq2054 is in the fault or charge-complete state, the ICTL output is driven low. This output can be used to disconnect the capacitor usually present in the charger across the positive and negative battery terminals, preventing the cap from supplying large inrush currents to a newly inserted battery. Such inrush currents may trip the overcurrent protection circuitry usually present in Li-Ion battery packs.

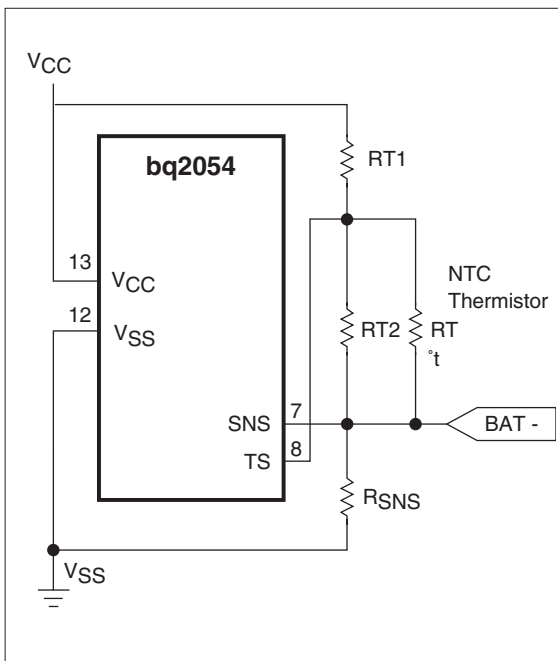

Figure 5. Configuring Temperature Sensing

Temperature Monitoring

The bq2054 monitors temperature by examining the voltage presented between the TS and SNS pins by a resistor network that includes a Negative Temperature Coefficient (NTC) thermistor. Resistance variations around that value are interpreted as being proportional to the battery temperature (see Figure 6).

The temperature thresholds used by the bq2054 and their corresponding TS pin voltage are:

- TCO (Temperature Cutoff): Higher limit of the temperature range in which charging is allowed. $V_{TCO} = 0.4 * V_{CC}$
- HTF (High-Temperature Fault): Threshold to which temperature must drop after temperature cutoff is exceeded before charging can begin again. $V_{HTF} = 0.44 * V_{CC}$
- LTF (Low-Temperature Fault): Lower limit of the temperature range in which charging is allowed. $V_{LTF} = 0.6 * V_{CC}$

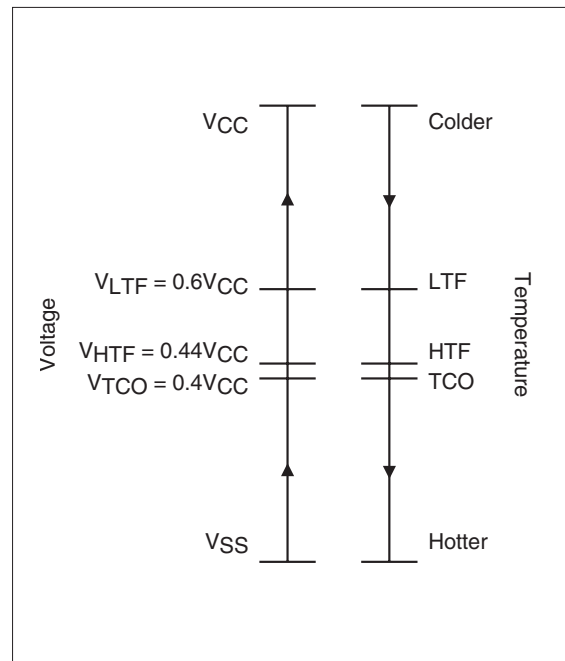

Figure 6. Voltage Equivalent of Temperature

bq2054

A resistor-divider network can be implemented that presents the defined voltage levels to the TS pin at the desired temperatures (see Figure 6).

The equations for determining RT1 and RT2 are:

Equation 3

$$0.6 * V_{CC} = \frac{(V_{CC} - 0.250)}{1 + \frac{RT1 * (RT2 + R_{LTF})}{(RT2 * R_{LTF})}}$$

Equation 4

$$0.44 = \frac{1}{1 + \frac{RT1 * (RT2 + R_{HTF})}{(RT2 * R_{HTF})}}$$

where:

- R_{LTF} = thermistor resistance at LTF
- R_{HTF} = thermistor resistance at HTF

TCO is determined by the values of RT1 and RT2. 1% resistors are recommended.

Disabling Temperature Sensing

Temperature sensing can be disabled by placing 10kΩ resistors between TS and SNS and between SNS and VCC.

Maximum Time-Out

MTO is programmed from 1 to 24 hours by an R-C network on the TM pin (see Figure 7) per the equation:

Equation 5

$$t_{MTO} = 0.5 * R * C$$

Where R is in kΩ and C is in μF, t_{MTO} is in hours. The maximum value for C (0.1μF) is typically used.

The MTO timer is reset at the beginning of fast charge and when fast charge transitions from the current regulated to the voltage regulated mode. If MTO expires during the current regulated phase, the bq2054 enters the Fault state and terminates charge. If the MTO timer expires during the voltage regulated phase, fast charging terminates and the bq2054 enters the Charge Complete state.

The MTO timer is suspended (but not reset) during the out-of-range temperature (Charge Pending) state.

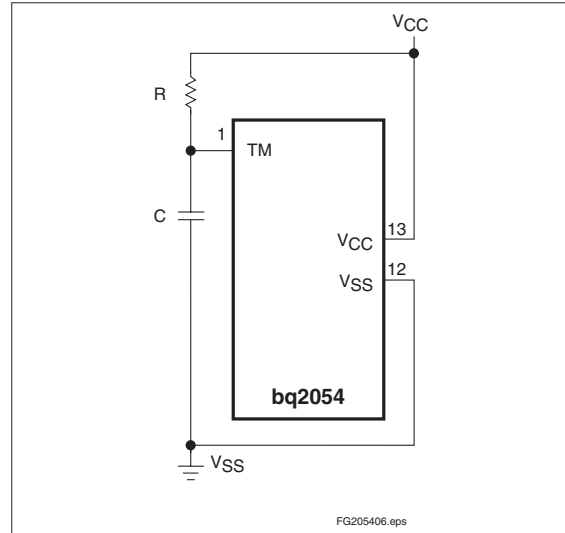

Figure 7. R-C Network for Setting MTO

Charge Regulation

The bq2054 controls charging through pulse-width modulation of the MOD output pin, supporting both constant-current and constant-voltage regulation. Charge current is monitored at the SNS pin, and charge voltage is monitored at the BAT pin. These voltages are compared to an internal reference, and the MOD output modulated to maintain the desired value.

Voltage at the SNS pin is determined by the value of resistor R_{SNS} , so nominal regulated current is set by:

Equation 6

$$I_{MAX} = 0.250V/R_{SNS}$$

The switching frequency of the MOD output is determined by an external capacitor (C_{PWM}) between the pin TPWM and ground, per the following:

Equation 7

$$F_{PWM} = 0.1/C_{PWM}$$

Where C is in μF and F is in kHz. A typical switching rate is 100kHz, implying $C_{PWM} = 0.001\mu F$. MOD pulse width is modulated between 0 and 90% of the switching period.

To prevent oscillation in the voltage and current control loops, frequency compensation networks (C or R-C) are typically required on the V_{COMP} and I_{COMP} pins (respectively).

Absolute Maximum Ratings

Symbol	Parameter	Minimum	Maximum	Unit	Notes
V _{CC}	V _{CC} relative to V _{SS}	-0.3	+7.0	V	
V _T	DC voltage applied on any pin excluding V _{CC} relative to V _{SS}	-0.3	+7.0	V	
T _{OPR}	Operating ambient temperature	-20	+70	°C	Commercial
T _{STG}	Storage temperature	-55	+125	°C	
T _{SOLDER}	Soldering temperature	-	+260	°C	10 sec. max.

Note: Permanent device damage may occur if **Absolute Maximum Ratings** are exceeded. Functional operation should be limited to the Recommended DC Operating Conditions detailed in this data sheet. Exposure to conditions beyond the operational limits for extended periods of time may affect device reliability.

bq2054

DC Thresholds (T_A = TOPR; V_{CC} = 5V ±10%)

Symbol	Parameter	Rating	Unit	Tolerance	Notes
V _{REF}	Internal reference voltage	2.05	V	1%	T _A = 25°C
	Temperature coefficient	-0.5	mV/°C	10%	
V _{LTF}	TS maximum threshold	0.6 * V _{CC}	V	±0.03V	Low-temperature fault
V _{HTF}	TS hysteresis threshold	0.44 * V _{CC}	V	±0.03V	High-temperature fault
V _{TCO}	TS minimum threshold	0.4 * V _{CC}	V	±0.03V	Temperature cutoff
V _{HCO}	High cutoff voltage	2.3V	V	1%	
V _{MIN}	Under-voltage threshold at BAT	0.2 * V _{CC}	V	±0.03V	
V _{LCO}	Low cutoff voltage	0.8	V	±0.03V	
V _{SNS}	Current sense at SNS	0.250	V	10%	I _{MAX}
		0.050	V	10%	I _{COND}

Recommended DC Operating Conditions (T_A = T_{OPR})

Symbol	Parameter	Minimum	Typical	Maximum	Unit	Notes
V _{CC}	Supply voltage	4.5	5.0	5.5	V	
V _{TEMP}	Temperature sense voltage	0	-	V _{CC}	V	V _{TS} - V _{SNS}
V _{CELL}	Per cell battery voltage input	0	-	V _{CC}	V	V _{BAT} - V _{SNS}
I _{CC}	Supply current	-	2	4	mA	Outputs unloaded
I _{IZ}	DSEL tri-state open detection	-2	-	2	μA	Note 2
	I _{TERM} tri-state open detection	-2	-	2	μA	
V _{IH}	Logic input high	V _{CC} -0.3	-	-	V	DSEL, I _{TERM}
V _{IL}	Logic input low	-	-	V _{SS} +0.3	V	DSEL, I _{TERM}
V _{OH}	LED ₁₋₃ , $\overline{\text{ICTL}}$, output high	V _{CC} -0.8	-	-	V	I _{OH} ≤ 10mA
	MOD output high	V _{CC} -0.8	-	-	V	I _{OH} ≤ 10mA
V _{OL}	LED ₁₋₃ , $\overline{\text{ICTL}}$, output low	-	-	V _{SS} +0.8V	V	I _{OL} ≤ 10mA
	MOD output low	-	-	V _{SS} +0.8V	V	I _{OL} ≤ 10mA
	LCOM output low	-	-	V _{SS} +0.5	V	I _{OL} ≤ 30mA
I _{OH}	LED ₁₋₃ , $\overline{\text{ICTL}}$, source	-10	-	-	mA	V _{OH} = V _{CC} -0.5V
	MOD source	-5.0	-	-	mA	V _{OH} = V _{CC} -0.5V
I _{OL}	LED ₁₋₃ , $\overline{\text{ICTL}}$, sink	10	-	-	mA	V _{OL} = V _{SS} +0.5V
	MOD sink	5	-	-	mA	V _{OL} = V _{SS} +0.8V
	LCOM sink	30	-	-	mA	V _{OL} = V _{SS} +0.5V
I _{IL}	DSEL logic input low source	-	-	+30	μA	V = V _{SS} to V _{SS} + 0.3V, Note 2
	I _{TERM} logic input low source	-	-	+70	μA	V = V _{SS} to V _{SS} + 0.3V
I _{IH}	DSEL logic input high source	-30	-	-	μA	V = V _{CC} - 0.3V to V _{CC}
	I _{TERM} logic input high source	-70	-	-	μA	V = V _{CC} - 0.3V to V _{CC}

- Notes:**
1. All voltages relative to V_{SS} except where noted.
 2. Conditions during initialization after V_{CC} applied.

bq2054

Impedance

Symbol	Parameter	Minimum	Typical	Maximum	Unit	Notes
R _{BATZ}	BAT pin input impedance	50	-	-	MΩ	
R _{SNSZ}	SNS pin input impedance	50	-	-	MΩ	
R _{TSZ}	TS pin input impedance	50	-	-	MΩ	
R _{PROG1}	Soft-programmed pull-up or pull-down resistor value (for programming)	-	-	10	kΩ	DSEL
R _{PROG2}	Pull-up or pull-down resistor value	-	-	3	kΩ	I _{TERM}
R _{MTO}	Charge timer resistor	20	-	480	kΩ	

Timing (T_A = T_{OPR}; V_{CC} = 5V ±10%)

Symbol	Parameter	Minimum	Typical	Maximum	Unit	Notes
t _{MTO}	Charge time-out range	1	-	24	hours	See Figure 7
t _{QT}	Pre-charge qual test time-out period	-	t _{MTO}	-	-	
t _{HO}	Termination hold-off period	1.14	-	1.52	sec.	
t _{IMIN}	Min. current detect filter period	80		160	msec.	
F _{PWM}	PWM regulator frequency range	-	100		kHz	C _{PWM} = 0.001μF (equation 7)

Capacitance

Symbol	Parameter	Minimum	Typical	Maximum	Unit
C _{MTO}	Charge timer capacitor	-	-	0.1	μF
C _{PWM}	PWM R-C capacitance	-	0.001	-	μF

bq2054

16-Pin DIP Narrow (PN)

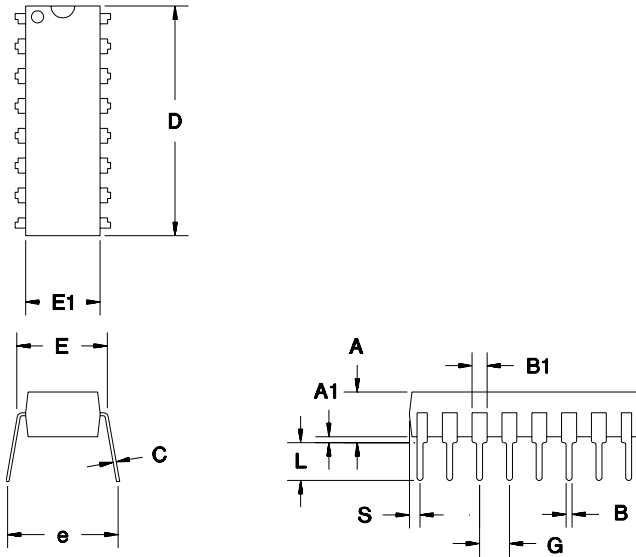

16-Pin PN (0.300" DIP)

Dimension	Inches		Millimeters	
	Min.	Max.	Min.	Max.
A	0.160	0.180	4.06	4.57
A1	0.015	0.040	0.38	1.02
B	0.015	0.022	0.38	0.56
B1	0.055	0.065	1.40	1.65
C	0.008	0.013	0.20	0.33
D	0.740	0.770	18.80	19.56
E	0.300	0.325	7.62	8.26
E1	0.230	0.280	5.84	7.11
e	0.300	0.370	7.62	9.40
G	0.090	0.110	2.29	2.79
L	0.115	0.150	2.92	3.81
S	0.020	0.040	0.51	1.02

16-Pin SOIC Narrow (SN)

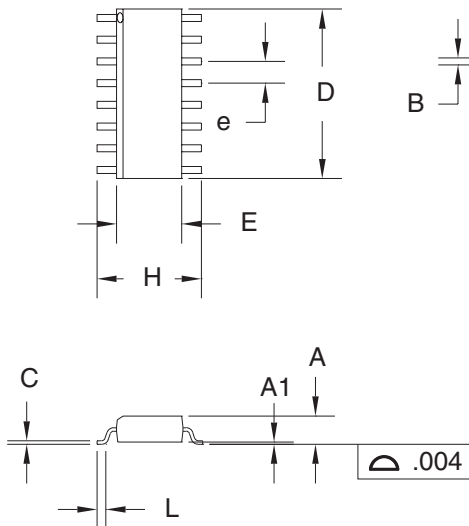

16-Pin SN (0.150" SOIC)

Dimension	Inches		Millimeters	
	Min.	Max.	Min.	Max.
A	0.060	0.070	1.52	1.78
A1	0.004	0.010	0.10	0.25
B	0.013	0.020	0.33	0.51
C	0.007	0.010	0.18	0.25
D	0.385	0.400	9.78	10.16
E	0.150	0.160	3.81	4.06
e	0.045	0.055	1.14	1.40
H	0.225	0.245	5.72	6.22
L	0.015	0.035	0.38	0.89

Data Sheet Revision History

Change No.	Page No.	Description	Nature of Change
1	5, 7, 8, 10	Value Change	Changed V_{SNS} and I_{MAX}
2	5, 10	Value Change	Changed V_{REF}
3	10	Coefficient Addition	Temperature coefficient added
4	5	New state diagram	Diagram inserted
4	1, 2, 8, 12	NC pin replaced with \overline{ICTL}	
4	3, 5, 13	Termination hold-off period added I_{MIN} detect filtering added	
5	11	V_{HCO} Rating changed to 2.3V V_{HCO} Tolerance changed to 1%	Changed values for V_{HCO}
6	13	t_{QT} in Timing Specifications	t_{QT} changed from $(0.16 * t_{MTO})$ to t_{MTO}
7	5	I_{TERM} in Table 2	Z changes to Float
7	8	Figure 6	RB1 and RB2 changed to RT1 and RT2
8	10	T_{OPR}	Deleted industrial temperature range.

Notes: Change 3 = April 1996 C changes from Dec. 1995 B.
 Change 4 = Sept. 1996 D changes from April 1996 C.
 Change 5 = Nov. 1996 E changes from Sept. 1996 D.
 Change 6 = Oct. 1997 F changes from Nov. 1996 E.
 Change 7 = Oct. 1997 G changes from Oct. 1997 F.
 Change 8 = June 1999 H changes from Oct. 1997 G.

Ordering Information

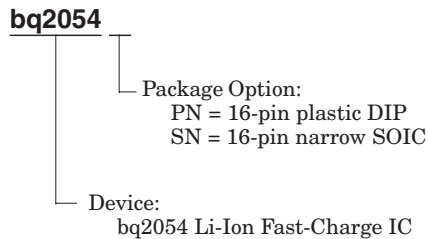

PACKAGING INFORMATION

Orderable part number	Status (1)	Material type (2)	Package Pins	Package qty Carrier	RoHS (3)	Lead finish/ Ball material (4)	MSL rating/ Peak reflow (5)	Op temp (°C)	Part marking (6)
BQ2054PN	Active	Production	PDIP (N) 16	-	-	Call TI	Call TI	-20 to 70	2054PN-G
BQ2054PN.B	Active	Production	PDIP (N) 16	-	-	Call TI	Call TI	-20 to 70	2054PN-G
BQ2054SN	Active	Production	SOIC (D) 16	-	-	Call TI	Call TI	-20 to 70	2054 (-G, G)
BQ2054SN.B	Active	Production	SOIC (D) 16	-	-	Call TI	Call TI	-20 to 70	2054 (-G, G)
BQ2054SNTR	Active	Production	SOIC (D) 16	-	-	Call TI	Call TI	-20 to 70	2054 (-G, G)
BQ2054SNTR.B	Active	Production	SOIC (D) 16	-	-	Call TI	Call TI	-20 to 70	2054 (-G, G)

(1) **Status:** For more details on status, see our [product life cycle](#).

(2) **Material type:** When designated, preproduction parts are prototypes/experimental devices, and are not yet approved or released for full production. Testing and final process, including without limitation quality assurance, reliability performance testing, and/or process qualification, may not yet be complete, and this item is subject to further changes or possible discontinuation. If available for ordering, purchases will be subject to an additional waiver at checkout, and are intended for early internal evaluation purposes only. These items are sold without warranties of any kind.

(3) **RoHS values:** Yes, No, RoHS Exempt. See the [TI RoHS Statement](#) for additional information and value definition.

(4) **Lead finish/Ball material:** Parts may have multiple material finish options. Finish options are separated by a vertical ruled line. Lead finish/Ball material values may wrap to two lines if the finish value exceeds the maximum column width.

(5) **MSL rating/Peak reflow:** The moisture sensitivity level ratings and peak solder (reflow) temperatures. In the event that a part has multiple moisture sensitivity ratings, only the lowest level per JEDEC standards is shown. Refer to the shipping label for the actual reflow temperature that will be used to mount the part to the printed circuit board.

(6) **Part marking:** There may be an additional marking, which relates to the logo, the lot trace code information, or the environmental category of the part.

Multiple part markings will be inside parentheses. Only one part marking contained in parentheses and separated by a "-" will appear on a part. If a line is indented then it is a continuation of the previous line and the two combined represent the entire part marking for that device.

Important Information and Disclaimer:The information provided on this page represents TI's knowledge and belief as of the date that it is provided. TI bases its knowledge and belief on information provided by third parties, and makes no representation or warranty as to the accuracy of such information. Efforts are underway to better integrate information from third parties. TI has taken and continues to take reasonable steps to provide representative

and accurate information but may not have conducted destructive testing or chemical analysis on incoming materials and chemicals. TI and TI suppliers consider certain information to be proprietary, and thus CAS numbers and other limited information may not be available for release.

In no event shall TI's liability arising out of such information exceed the total purchase price of the TI part(s) at issue in this document sold by TI to Customer on an annual basis.

D (R-PDSO-G16)

PLASTIC SMALL OUTLINE



- NOTES:
- A. All linear dimensions are in inches (millimeters).
 - B. This drawing is subject to change without notice.
 - C. Body length does not include mold flash, protrusions, or gate burrs. Mold flash, protrusions, or gate burrs shall not exceed 0.006 (0,15) each side.
 - D. Body width does not include interlead flash. Interlead flash shall not exceed 0.017 (0,43) each side.
 - E. Reference JEDEC MS-012 variation AC.

N (R-PDIP-T**)

PLASTIC DUAL-IN-LINE PACKAGE

16 PINS SHOWN



- NOTES:
- A. All linear dimensions are in inches (millimeters).
 - B. This drawing is subject to change without notice.
 - Falls within JEDEC MS-001, except 18 and 20 pin minimum body length (Dim A).
 - The 20 pin end lead shoulder width is a vendor option, either half or full width.

IMPORTANT NOTICE AND DISCLAIMER

TI PROVIDES TECHNICAL AND RELIABILITY DATA (INCLUDING DATASHEETS), DESIGN RESOURCES (INCLUDING REFERENCE DESIGNS), APPLICATION OR OTHER DESIGN ADVICE, WEB TOOLS, SAFETY INFORMATION, AND OTHER RESOURCES "AS IS" AND WITH ALL FAULTS, AND DISCLAIMS ALL WARRANTIES, EXPRESS AND IMPLIED, INCLUDING WITHOUT LIMITATION ANY IMPLIED WARRANTIES OF MERCHANTABILITY, FITNESS FOR A PARTICULAR PURPOSE OR NON-INFRINGEMENT OF THIRD PARTY INTELLECTUAL PROPERTY RIGHTS.

These resources are intended for skilled developers designing with TI products. You are solely responsible for (1) selecting the appropriate TI products for your application, (2) designing, validating and testing your application, and (3) ensuring your application meets applicable standards, and any other safety, security, regulatory or other requirements.

These resources are subject to change without notice. TI grants you permission to use these resources only for development of an application that uses the TI products described in the resource. Other reproduction and display of these resources is prohibited. No license is granted to any other TI intellectual property right or to any third party intellectual property right. TI disclaims responsibility for, and you fully indemnify TI and its representatives against any claims, damages, costs, losses, and liabilities arising out of your use of these resources.

TI's products are provided subject to [TI's Terms of Sale](#), [TI's General Quality Guidelines](#), or other applicable terms available either on [ti.com](#) or provided in conjunction with such TI products. TI's provision of these resources does not expand or otherwise alter TI's applicable warranties or warranty disclaimers for TI products. Unless TI explicitly designates a product as custom or customer-specified, TI products are standard, catalog, general purpose devices.

TI objects to and rejects any additional or different terms you may propose.

Copyright © 2026, Texas Instruments Incorporated

Last updated 10/2025