

DS90CF3x6 3.3-V LVDS Receiver 24-Bit Or 18-Bit Flat Panel Display (FPD) Link, 85 MHz

1 Features

- 20-MHz to 85-MHz Shift Clock Support
- Rx Power Consumption <142 mW (Typical) at 85-MHz Grayscale
- Rx Power-Down Mode <1.44 mW (Maximum)
- ESD Rating >7 kV (HBM), >700 V (EIAJ)
- Supports VGA, SVGA, XGA, and Single Pixel SXGA
- PLL Requires No External Components
- Compatible With TIA/EIA-644 LVDS Standard
- Low Profile 56-Pin or 48-Pin TSSOP Package
- DS90CF386 Also Available in a 64-Pin, 0.8-mm, Fine Pitch Ball Grid Array (NFBGA) Package

2 Applications

- Video Displays
- Printers and Imaging
- Digital Video Transport
- Machine Vision
- Open LDI-to-RGB Bridge

3 Description

The DS90CF386 receiver converts four LVDS (Low Voltage Differential Signaling) data streams back into parallel 28 bits of LVCMOS data. Also available is the DS90CF366 receiver that converts three LVDS data streams back into parallel 21 bits of LVCMOS data. The outputs of both receivers strobe on the falling edge. A rising edge or falling edge strobe transmitter will interoperate with a falling edge strobe receiver without any translation logic.

The receiver LVDS clock operates at rates from 20 MHz to 85 MHz. The device phase-locks to the input LVDS clock, samples the serial bit streams at the LVDS data lines, and converts them into parallel output data. At an incoming clock rate of 85 MHz, each LVDS input line is running at a bit rate of 595 Mbps, resulting in a maximum throughput of 2.38 Gbps for the DS90CF386 and 1.785 Gbps for the DS90CF366.

The use of these serial link devices is ideal for solving EMI and cable size problems associated with transmitting data over wide, high-speed parallel LVCMOS interfaces. Both devices are offered in TSSOP packages. The DS90CF386 is also offered in a 64-pin, 0.8-mm, fine pitch ball grid array (NFBGA) package which provides a 44% reduction in PCB footprint compared to the 56-pin TSSOP package.

Device Information⁽¹⁾

PART NUMBER	PACKAGE	BODY SIZE (NOM)
DS90CF366	TSSOP (48)	12.50 mm x 6.10 mm
DS90CF386	TSSOP (56)	14.00 mm x 6.10 mm
	NFBGA (64)	8.00 mm x 8.00 mm

(1) For all available packages, see the orderable addendum at the end of the data sheet.

Typical Application Block Diagram (DS90CF366)

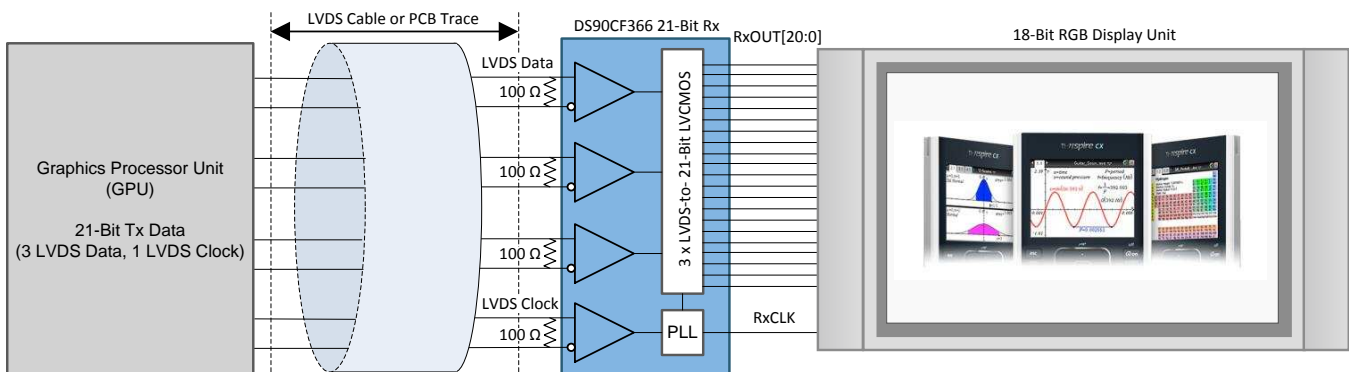

Copyright © 2016, Texas Instruments Incorporated



An IMPORTANT NOTICE at the end of this data sheet addresses availability, warranty, changes, use in safety-critical applications, intellectual property matters and other important disclaimers. PRODUCTION DATA.

Table of Contents

1	Features	1			
2	Applications	1			
3	Description	1			
4	Revision History	2			
5	Pin Configuration and Functions	3			
6	Specifications	7			
	6.1 Absolute Maximum Ratings	7			
	6.2 ESD Ratings	7			
	6.3 Recommended Operating Conditions	7			
	6.4 Thermal Information	7			
	6.5 Electrical Characteristics	8			
	6.6 Switching Characteristics	9			
	6.7 Timing Diagrams	9			
	6.8 Typical Characteristics	16			
7	Detailed Description	17			
	7.1 Overview	17			
	7.2 Functional Block Diagrams	17			
	7.3 Feature Description	18			
	7.4 Device Functional Modes	19			
8	Application and Implementation	20			
	8.1 Application Information	20			
	8.2 Typical Applications	20			
9	Power Supply Recommendations	26			
10	Layout	26			
	10.1 Layout Guidelines	26			
	10.2 Layout Examples	26			
11	Device and Documentation Support	28			
	11.1 Documentation Support	28			
	11.2 Community Resources	28			
	11.3 Trademarks	28			
	11.4 Electrostatic Discharge Caution	28			
	11.5 Glossary	28			
12	Mechanical, Packaging, and Orderable Information	28			

4 Revision History

NOTE: Page numbers for previous revisions may differ from page numbers in the current version.

Changes from Revision I (April 2013) to Revision J	Page
<ul style="list-style-type: none"> • Added <i>ESD Ratings</i> table, <i>Feature Description</i> section, <i>Device Functional Modes</i>, <i>Application and Implementation</i> section, <i>Power Supply Recommendations</i> section, <i>Layout</i> section, <i>Device and Documentation Support</i> section, and <i>Mechanical, Packaging, and Orderable Information</i> section 	1
<ul style="list-style-type: none"> • Changed Figure 8 and Figure 9 to clarify that TxIN on Tx is the same as RxOUT on Rx 	12
<ul style="list-style-type: none"> • Changed title of DS90CF366 mapping to clarify the make-up of the LVDS lines 	13
<ul style="list-style-type: none"> • Deleted references to power sequencing requirements for FPD-Link I transmitters 	19

Changes from Revision H (April 2013) to Revision I	Page
<ul style="list-style-type: none"> • Changed layout of National Data Sheet to TI format 	1

5 Pin Configuration and Functions

**DGG Package
48-Pin TSSOP
Top View**

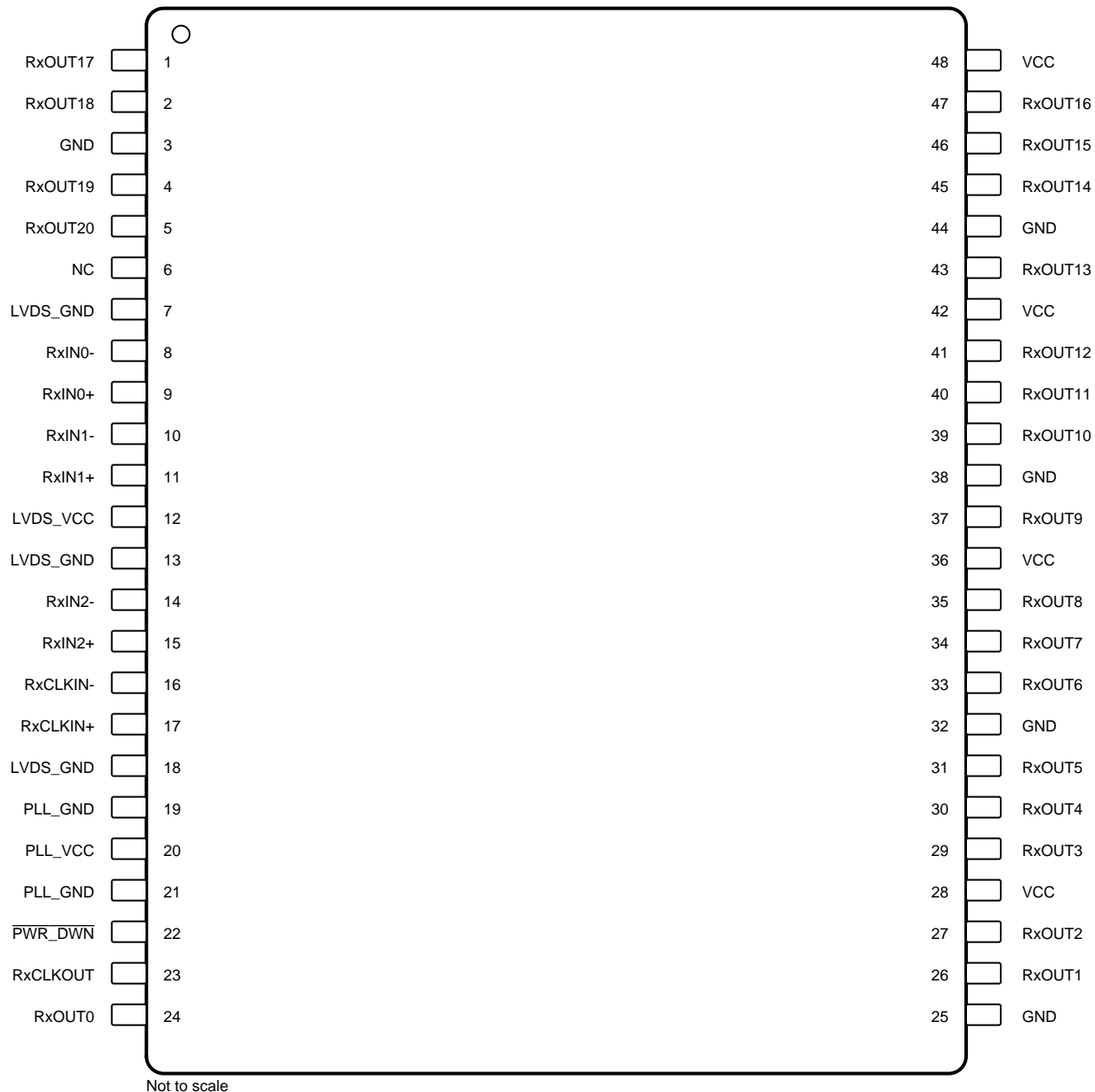

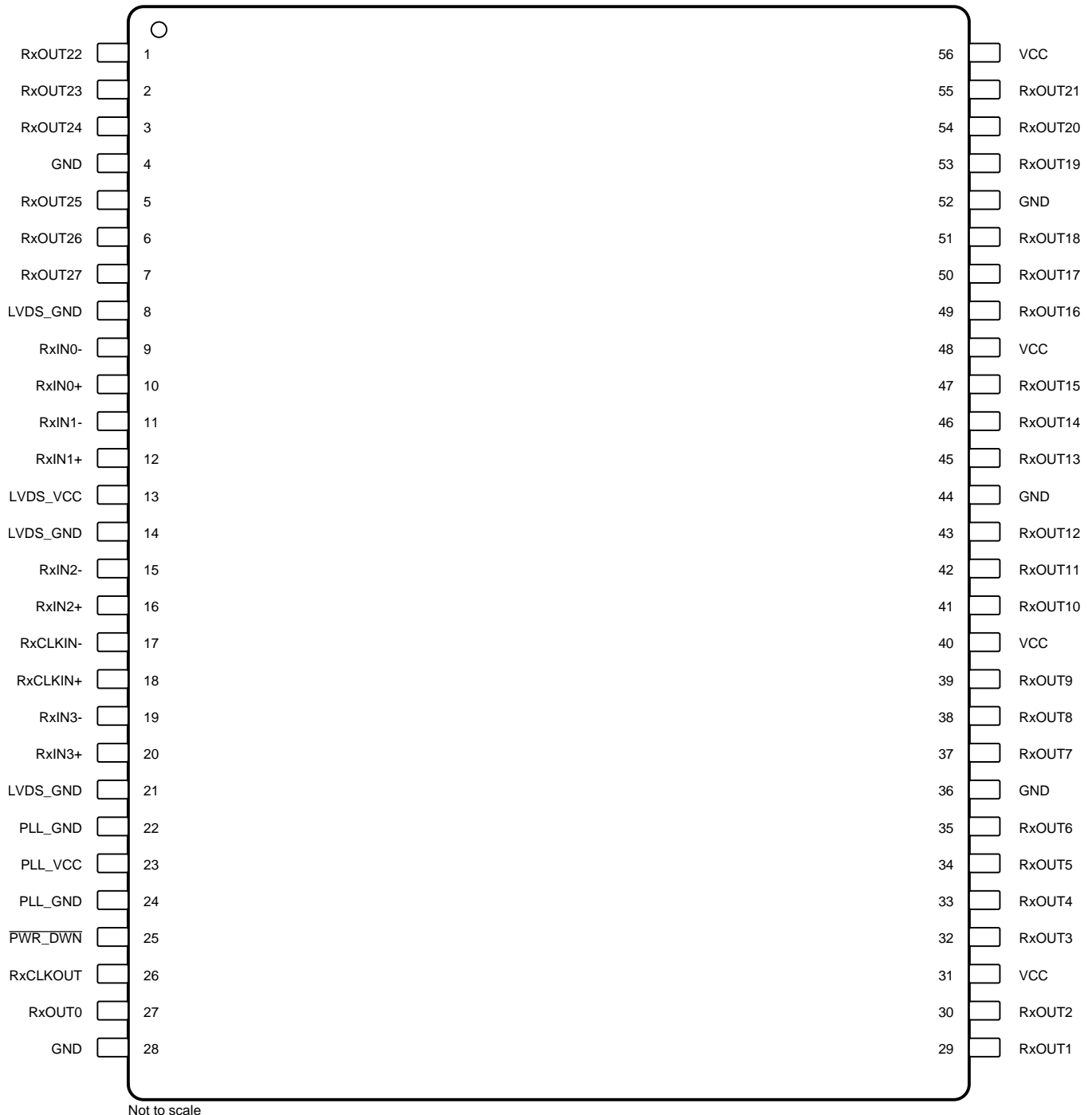
**DGG Package
56-Pin TSSOP
Top View**

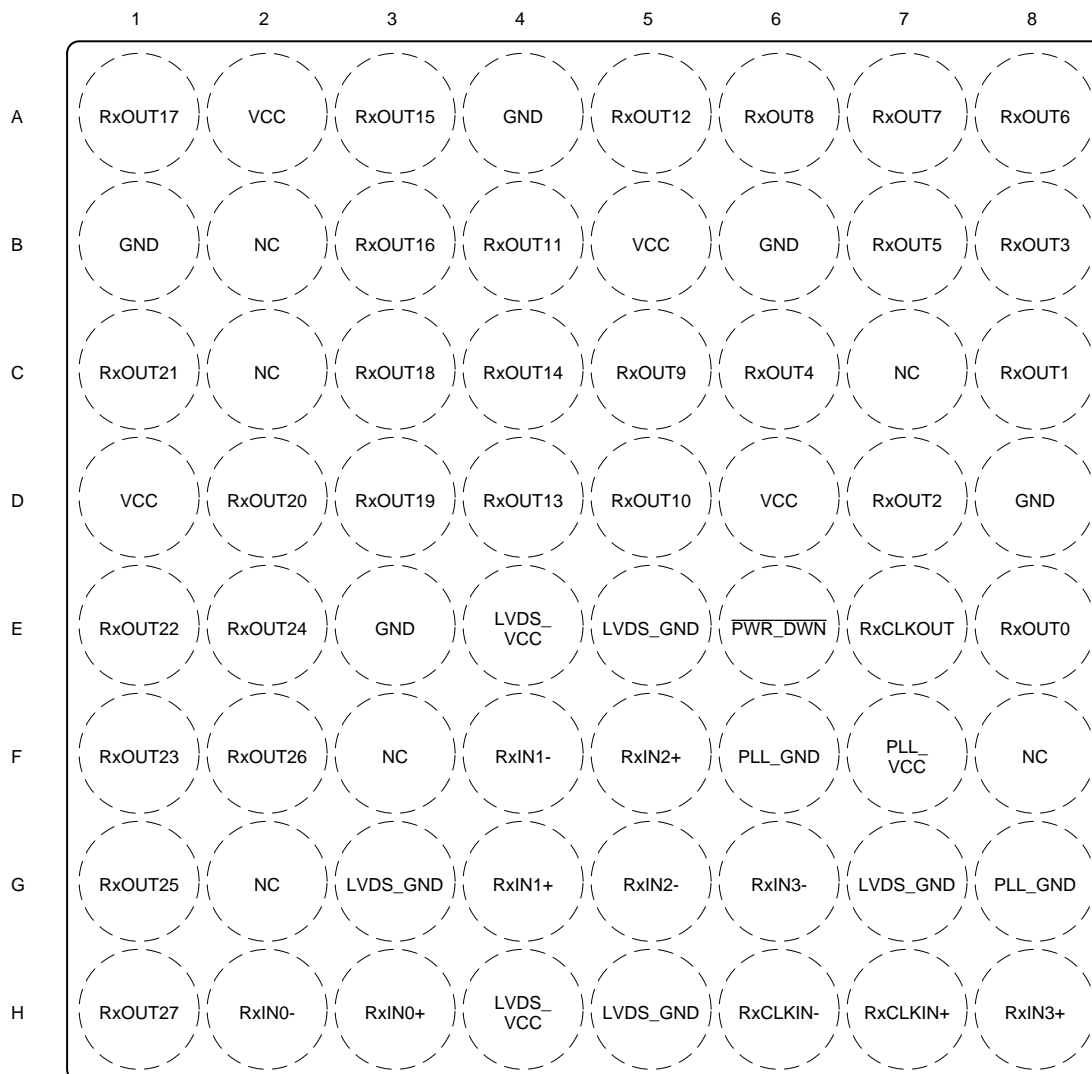
**NZC Package
64-Pin NFBGA
Top View**

Not to scale

Pin Functions

NAME	PIN			TYPE ⁽¹⁾	DESCRIPTION
	DS90CF366	DS90CF386			
	TSSOP	TSSOP	NFBGA		
GND	3, 25, 32, 38, 44	4, 28, 36, 44, 52	A4, B1, B6, D8, E3	G	Ground pins for LVCMOS outputs.
LVDS GND	7, 13, 18	8, 14, 21	E5, G3, G7, H5	G	Ground pins for LVDS inputs.
LVDS V _{CC}	12	13	E4, H4	P	Power supply pin for LVDS inputs.
NC	6	—	B2, C2, C7, F3, F8, G2	—	Pins not connected.
PLL GND	19, 21	22, 24	F6, G8	G	Ground pin for PLL.
PLL V _{CC}	20	23	F7	P	Power supply for PLL.

(1) G = Ground, I = Input, O = Output, and P = Power

Pin Functions (continued)

NAME	PIN			TYPE ⁽¹⁾	DESCRIPTION
	DS90CF366	DS90CF386			
	TSSOP	TSSOP	NFBGA		
$\overline{\text{PWR DWN}}$	22	25	E6	I	LVC MOS level input. When asserted (low input) the receiver outputs are low.
RxCLKIN+	17	18	H7	I	Positive LVDS differential clock input.
RxCLKIN-	16	17	H6	I	Negative LVDS differential clock input.
RxCLKOUT	23	26	E7	O	LVC MOS level clock output. The falling edge acts as data strobe.
RxIN0+	9	10	H3	I	Positive LVDS differential data inputs.
RxIN0-	8	9	H2	I	Negative LVDS differential data inputs.
RxIN1+	11	12	G4	I	Positive LVDS differential data inputs.
RxIN1-	10	11	F4	I	Negative LVDS differential data inputs.
RxIN2+	15	16	F5	I	Positive LVDS differential data inputs.
RxIN2-	14	15	G5	I	Negative LVDS differential data inputs.
RxIN3+	—	20	H8	I	Positive LVDS differential data inputs.
RxIN3-	—	19	G6	I	Negative LVDS differential data inputs.
RxOUT0	24	27	E8	O	LVC MOS level data output.
RxOUT1	26	29	C8	O	LVC MOS level data output.
RxOUT2	27	30	D7	O	LVC MOS level data output.
RxOUT3	29	32	B8	O	LVC MOS level data output.
RxOUT4	30	33	C6	O	LVC MOS level data output.
RxOUT5	31	34	B7	O	LVC MOS level data output.
RxOUT6	33	35	A8	O	LVC MOS level data output.
RxOUT7	34	37	A7	O	LVC MOS level data output.
RxOUT8	35	38	A6	O	LVC MOS level data output.
RxOUT9	37	39	C5	O	LVC MOS level data output.
RxOUT10	39	41	D5	O	LVC MOS level data output.
RxOUT11	40	42	B4	O	LVC MOS level data output.
RxOUT12	41	43	A5	O	LVC MOS level data output.
RxOUT13	43	45	D4	O	LVC MOS level data output.
RxOUT14	45	46	C4	O	LVC MOS level data output.
RxOUT15	46	47	A3	O	LVC MOS level data output.
RxOUT16	47	49	B3	O	LVC MOS level data output.
RxOUT17	1	50	A1	O	LVC MOS level data output.
RxOUT18	2	51	C3	O	LVC MOS level data output.
RxOUT19	4	53	D3	O	LVC MOS level data output.
RxOUT20	5	54	D2	O	LVC MOS level data output.
RxOUT21	—	55	C1	O	LVC MOS level data output.
RxOUT22	—	1	E1	O	LVC MOS level data output.
RxOUT23	—	2	F1	O	LVC MOS level data output.
RxOUT24	—	3	E2	O	LVC MOS level data output.
RxOUT25	—	5	G1	O	LVC MOS level data output.
RxOUT26	—	6	F2	O	LVC MOS level data output.
RxOUT27	—	7	H1	O	LVC MOS level data output.
V _{CC}	28, 36, 42, 48	31, 40, 48, 56	A2, B5, D1, D6	P	Power supply pins for LVC MOS outputs.

6 Specifications

6.1 Absolute Maximum Ratings

over operating free-air temperature range (unless otherwise noted)⁽¹⁾

		MIN	MAX	UNIT
Supply voltage, V_{CC}		-0.3	4	V
CMOS/LVCMOS output voltage		-0.3	$V_{CC} + 0.3$	V
LVDS receiver input voltage		-0.3	$V_{CC} + 0.3$	V
Power dissipation capacity at 25°C	DS90CF366, TSSOP package	1.61		W
	DS90CF386	TSSOP package	1.89	
		NFBGA package	2	
Lead temperature	TSSOP soldering (4 s)	260		°C
	NFBGA soldering, reflow (20 s)	220		
Operating junction temperature, T_J		150		°C
Storage temperature, T_{stg}		-65	150	°C

- (1) Stresses beyond those listed under *Absolute Maximum Ratings* may cause permanent damage to the device. These are stress ratings only, which do not imply functional operation of the device at these or any other conditions beyond those indicated under *Recommended Operating Conditions*. Exposure to absolute-maximum-rated conditions for extended periods may affect device reliability.

6.2 ESD Ratings

		VALUE	UNIT
$V_{(ESD)}$ Electrostatic discharge	Human-body model (HBM), per ANSI/ESDA/JEDEC JS-001 ⁽¹⁾	±7000	V
	Charged-device model (CDM), per JEDEC specification JESD22-C101 ⁽²⁾	±700	

- (1) JEDEC document JEP155 states that 500-V HBM allows safe manufacturing with a standard ESD control process.
 (2) JEDEC document JEP157 states that 250-V CDM allows safe manufacturing with a standard ESD control process.

6.3 Recommended Operating Conditions

over operating free-air temperature range (unless otherwise noted)

		MIN	NOM	MAX	UNIT
V_{CC}	Supply voltage	3	3.3	3.6	V
	Receiver input	0		2.4	V
V_{NOISE}	Supply noise voltage			100	mV _{PP}
T_A	Operating free-air temperature	-10	25	70	°C

6.4 Thermal Information

THERMAL METRIC ⁽¹⁾		DS90CF366	DS90CF386		UNIT
		DGG (TSSOP)	DGG (TSSOP)	NZC (NFBGA)	
		48 PINS	56 PINS	64 PINS	
$R_{\theta JA}$	Junction-to-ambient thermal resistance	67.8	64.6	65.7	°C/W
$R_{\theta JC(top)}$	Junction-to-case (top) thermal resistance	22.1	20.6	23.8	°C/W
$R_{\theta JB}$	Junction-to-board thermal resistance	34.8	33.3	44.9	°C/W
Ψ_{JT}	Junction-to-top characterization parameter	1.1	1	1	°C/W
Ψ_{JB}	Junction-to-board characterization parameter	34.5	33	44.9	°C/W

- (1) For more information about traditional and new thermal metrics, see the *Semiconductor and IC Package Thermal Metrics* application report, [SPRA953](#).

6.5 Electrical Characteristics

over operating free-air temperature range (unless otherwise noted)

PARAMETER		TEST CONDITIONS	MIN	TYP ⁽¹⁾	MAX	UNIT
LVC MOS DC SPECIFICATIONS						
V _{IH}	High level input voltage		2		V _{CC}	V
V _{IL}	Low level input voltage		GND		0.8	V
V _{OH}	High level output voltage	I _{OH} = -0.4 mA	2.7	3.3		V
V _{OL}	Low level output voltage	I _{OL} = 2 mA		0.06	0.3	V
V _{CL}	Input clamp voltage	I _{CL} = -18 mA		-0.79	-1.5	V
I _{IN}	Input current	V _{IN} = 0.4 V, 2.5 V or V _{CC}		1.8	15	μA
		V _{IN} = GND	-10	0		μA
I _{OS}	Output short circuit current	V _{OUT} = 0 V		-60	-120	mA
LVDS RECEIVER DC SPECIFICATIONS						
V _{TH}	Differential input high threshold	V _{CM} = 1.2 V			100	mV
V _{TL}	Differential input low threshold		-100			mV
I _{IN}	Input current	V _{IN} = 2.4 V, V _{CC} = 3.6 V			±10	μA
		V _{IN} = 0 V, V _{CC} = 3.6 V			±10	μA
RECEIVER SUPPLY CURRENT						
ICCRW	Receiver supply current worst case	C _L = 8 pF, worst case pattern, DS90CF386, see Figure 1 and Figure 4	f = 32.5 MHz	49	70	mA
			f = 37.5 MHz	53	75	mA
			f = 65 MHz	81	114	mA
			f = 85 MHz	96	135	mA
		C _L = 8 pF, worst case pattern, DS90CF366, see Figure 1 and Figure 4	f = 32.5 MHz	49	60	mA
			f = 37.5 MHz	53	65	mA
			f = 65 MHz	78	100	mA
			f = 85 MHz	90	115	mA
ICCRG	Receiver supply current, 16 grayscale	C _L = 8 pF, 16 grayscale pattern, see Figure 2 , Figure 3 , and Figure 4	f = 32.5 MHz	28	45	mA
			f = 37.5 MHz	30	47	mA
			f = 65 MHz	43	60	mA
			f = 85 MHz	43	70	mA
ICCRZ	Receiver supply current power down ⁽²⁾	Power Down = low receiver outputs stay low during power down mode		140	400	μA

 (1) Typical values are given for V_{CC} = 3.3 V and T_A = 25°C.

 (2) Current into device pins is defined as positive. Current out of device pins is defined as negative. Voltages are referenced to ground unless otherwise specified (except V_{OD} and ΔV_{OD}).

6.6 Switching Characteristics

over operating free-air temperature range (unless otherwise noted)

PARAMETER		TEST CONDITIONS	MIN	TYP ⁽¹⁾	MAX	UNIT
CLHT	CMOS or LVCMOS low-to-high transition time	See Figure 4		2	3.5	ns
CHLT	CMOS or LVCMOS high-to-low transition time	See Figure 4		1.8	3.5	ns
RSPos0	Receiver input strobe position for bit 0	f = 85 MHz, see Figure 11 and Figure 12	0.49	0.84	1.19	ns
RSPos1	Receiver input strobe position for bit 1	f = 85 MHz	2.17	2.52	2.87	ns
RSPos2	Receiver input strobe position for bit 2	f = 85 MHz	3.85	4.2	4.55	ns
RSPos3	Receiver input strobe position for bit 3	f = 85 MHz	5.53	5.88	6.23	ns
RSPos4	Receiver input strobe position for bit 4	f = 85 MHz	7.21	7.56	7.91	ns
RSPos5	Receiver input strobe position for bit 5	f = 85 MHz	8.89	9.24	9.59	ns
RSPos6	Receiver input strobe position for bit 6	f = 85 MHz	10.57	10.92	11.27	ns
RSKM	RxIN skew margin ⁽²⁾	f = 85 MHz, see Figure 13	290			ps
RCOP	RxCLK OUT period	See Figure 5	11.76	T	50	ns
RCOH	RxCLK OUT high time	f = 85 MHz, see Figure 5	4.5	5	7	ns
RCOL	RxCLK OUT low time	f = 85 MHz, see Figure 5	4	5	6.5	ns
RSRC	RxOUT setup to RxCLK OUT	f = 85 MHz, see Figure 5	2			ns
RHRC	RxOUT hold to RxCLK OUT	f = 85 MHz, see Figure 5	3.5			ns
RCCD	RxCLK IN to RxCLK OUT delay	25°C, V _{CC} = 3.3 V, see Figure 6	5.5	7	9.5	ns
RPLLS	Receiver phase lock loop set	See Figure 7			10	ms
RPDD	Receiver power down delay	See Figure 10			1	µs

(1) Typical values are given for V_{CC} = 3.3 V and T_A = 25°C.

(2) Receiver skew margin is defined as the valid data sampling region at the receiver inputs. This margin takes into account the transmitter pulse positions (min and max) and the receiver input setup and hold time (internal data sampling window - RSPos). This margin allows for LVDS interconnect skew, inter-symbol interference (both dependent on type/length of cable), and clock jitter (less than 150 ps).

6.7 Timing Diagrams

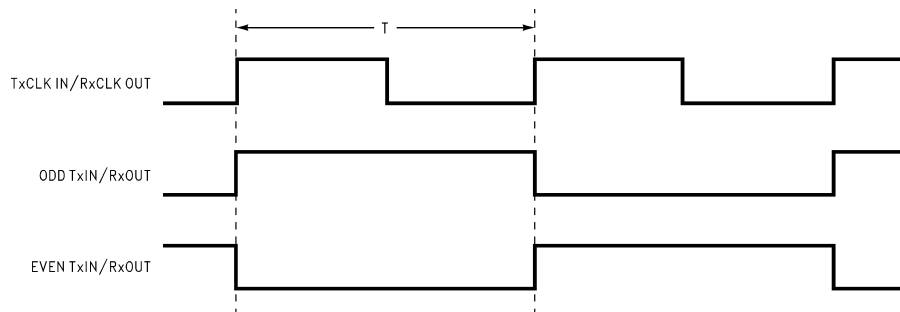
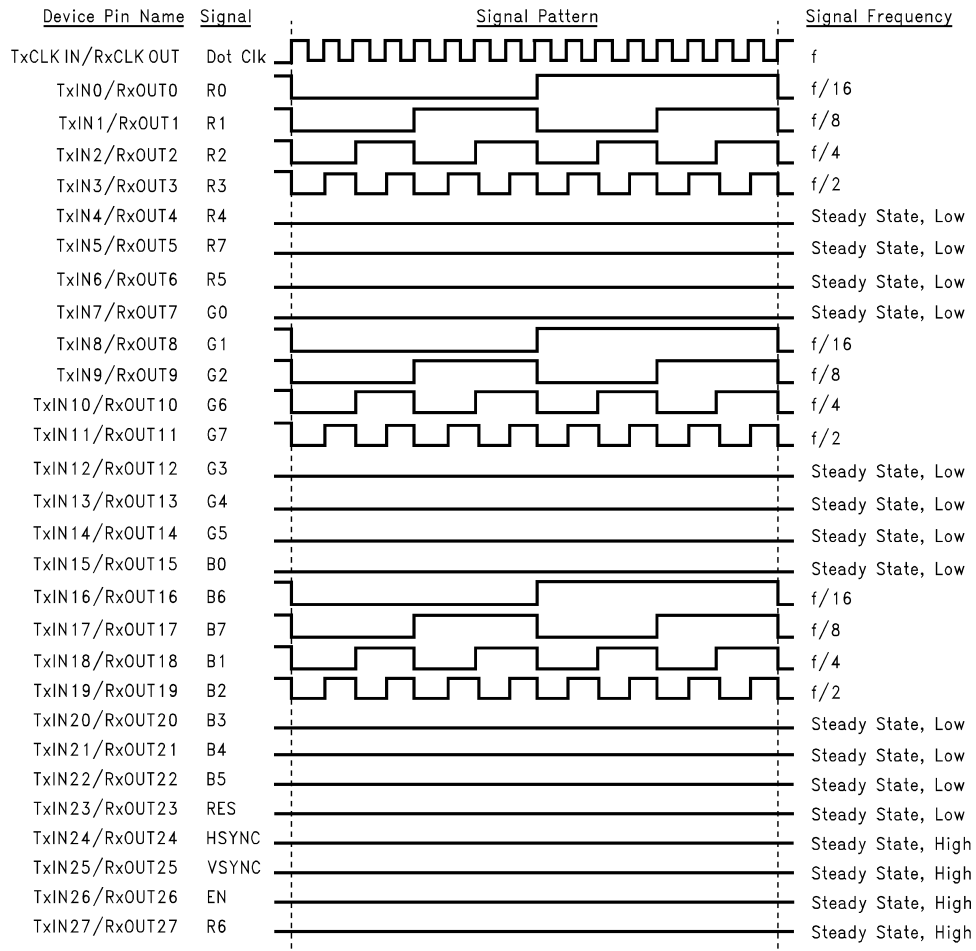

Figure 1. Test Pattern, Worst Case

Timing Diagrams (continued)



- (1) The worst case test pattern produces a maximum toggling of digital circuits, LVDS I/O, and CMOS or LVC MOS I/O.
- (2) The 16 grayscale test pattern tests device power consumption for a *typical* LCD display pattern. The test pattern approximates signal switching needed to produce groups of 16 vertical stripes across the display.
- (3) [Figure 1](#) and [Figure 3](#) show a falling edge data strobe (TxCLK IN/RxCLK OUT).
- (4) Recommended pin to signal mapping. Customer may choose to define differently.

Figure 2. Test Pattern, 16 Grayscale (DS90CF386)

Timing Diagrams (continued)

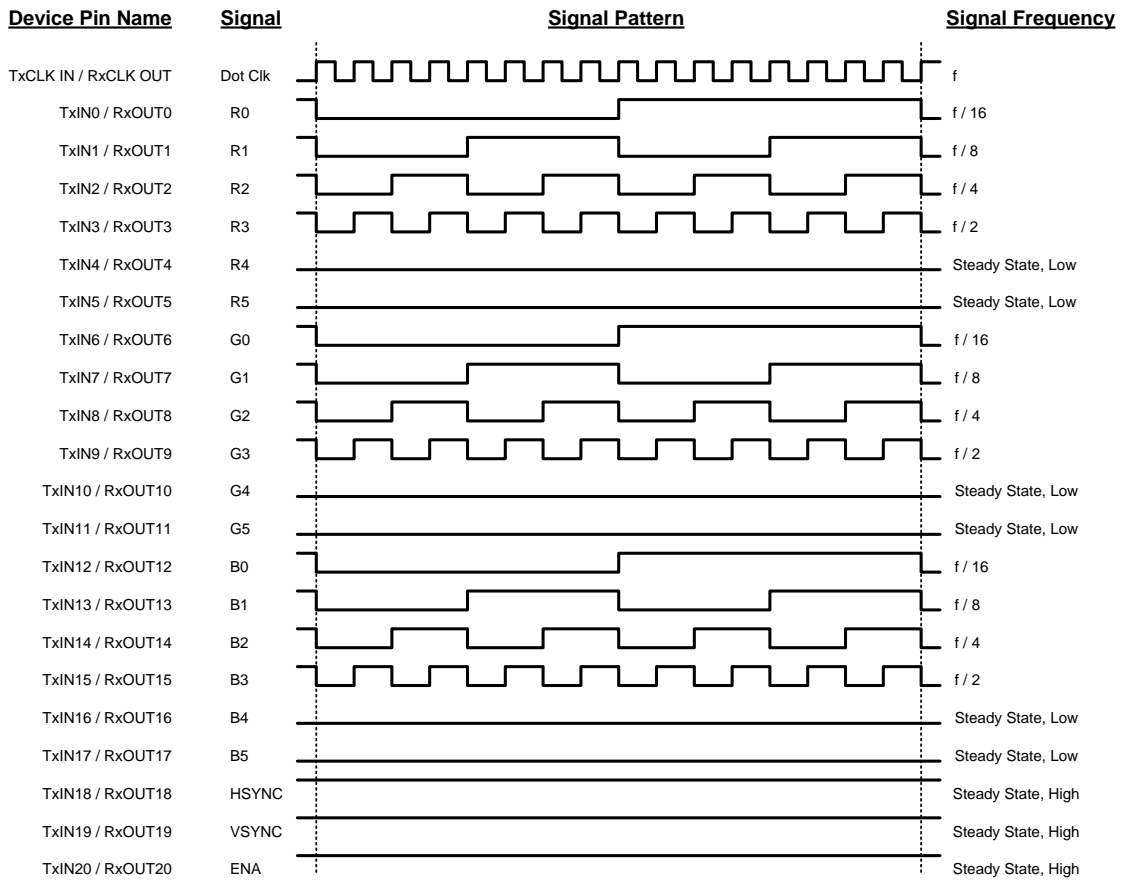

- (1) The worst case test pattern produces a maximum toggling of digital circuits, LVDS I/O, and CMOS or LVC MOS I/O.
- (2) The 16 grayscale test pattern tests device power consumption for a *typical* LCD display pattern. The test pattern approximates signal switching needed to produce groups of 16 vertical stripes across the display.
- (3) [Figure 1](#) and [Figure 3](#) show a falling edge data strobe (TxCLK IN/RxCLK OUT).
- (4) Recommended pin to signal mapping. Customer may choose to define differently.

Figure 3. Test Pattern, 16 Grayscale (DS90CF366)



Figure 4. DS90CF3x6 (Receiver) CMOS or LVC MOS Output Load and Transition Times

Timing Diagrams (continued)

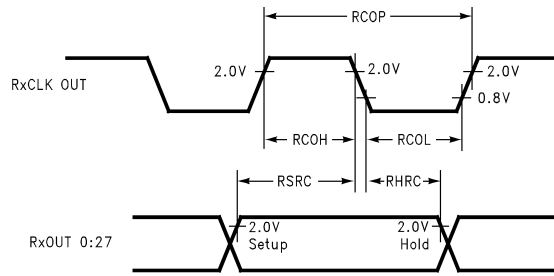

Figure 5. DS90CF3x6 (Receiver) Setup or Hold and High or Low Times

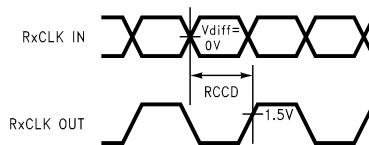

Figure 6. DS90CF3x6 (Receiver) Clock In to Clock Out Delay

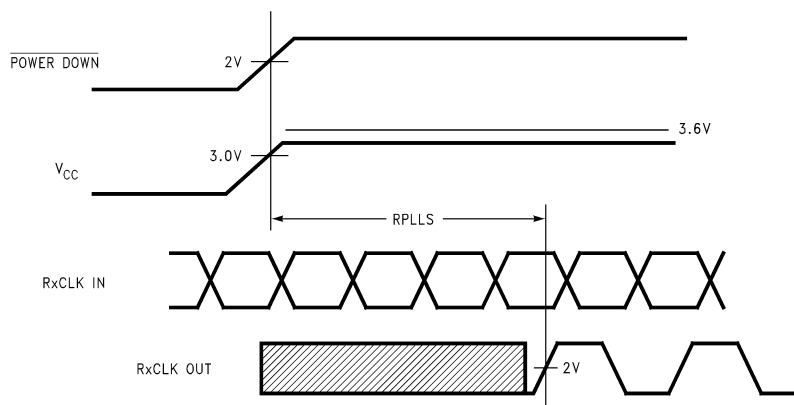

Figure 7. DS90CF3x6 (Receiver) Phase Lock Loop Set Time

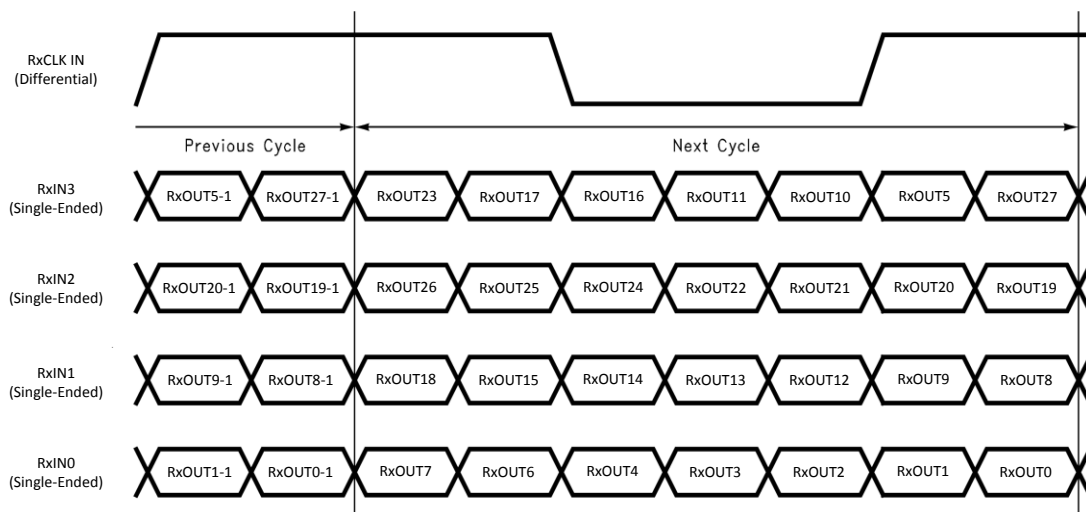

Figure 8. DS90CF386 Mapping of 28 LVCMOS Parallel Data to 4D + C LVDS Serialized Data

Timing Diagrams (continued)

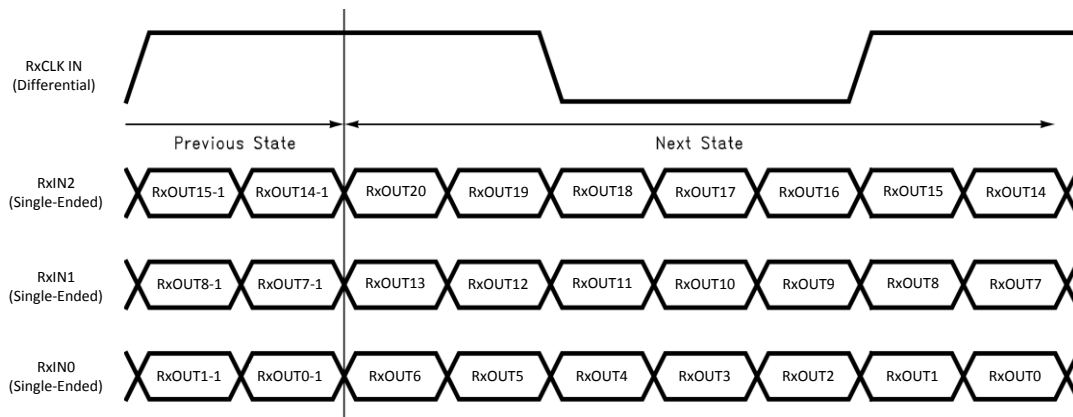

Figure 9. DS90CF366 Mapping of 21 LVC MOS Parallel Data to 3D + C LVDS Serialized Data

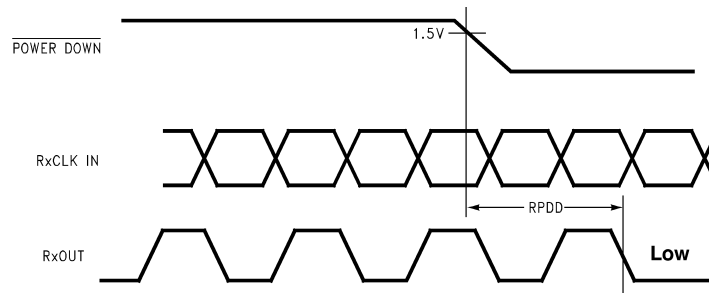

Figure 10. DS90CF366 (Receiver) Power Down Delay

Timing Diagrams (continued)

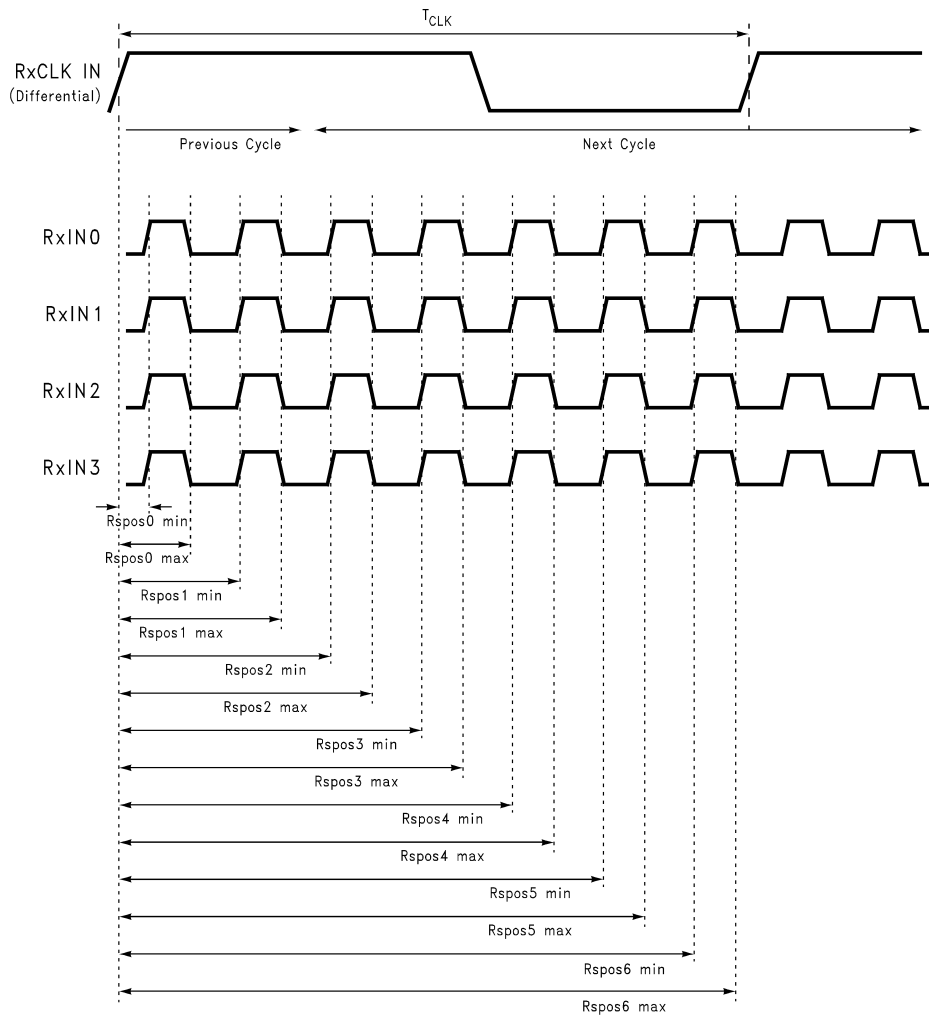

Figure 11. DS90CF386 (Receiver) LVDS Input Strobe Position

Timing Diagrams (continued)

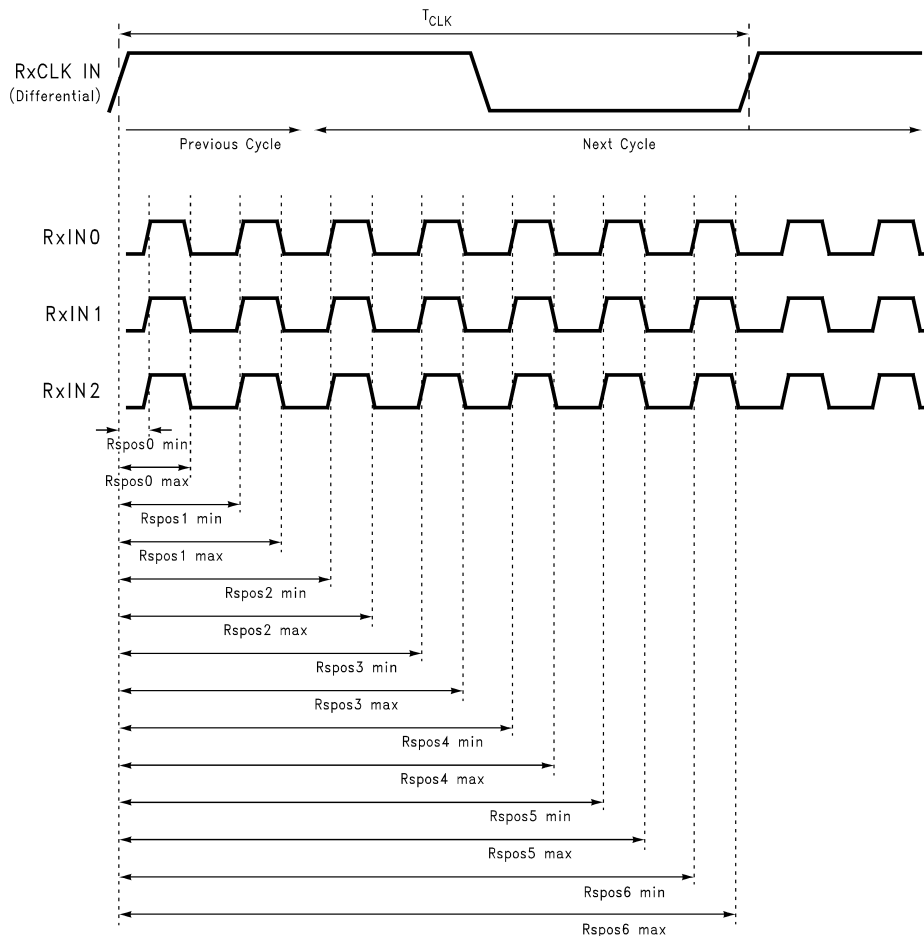
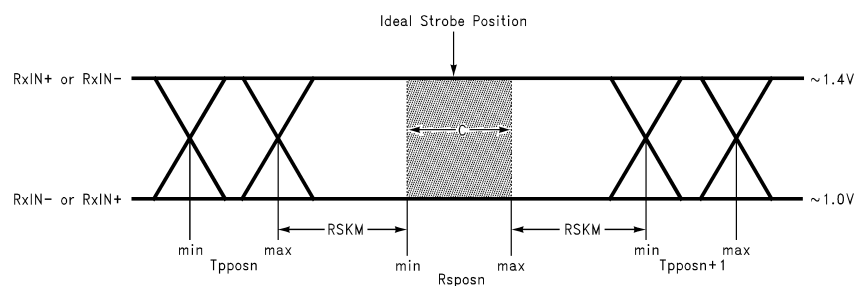

Figure 12. DS90CF366 (Receiver) LVDS Input Strobe Position



C: Setup and Hold Time (Internal data sampling window) defined by Rspos (receiver input strobe position) min and max

Tppos: Transmitter output pulse position (min and max)

Cable skew: Typically 10 ps–40 ps per foot, media dependent

RSKM = Cable skew (type, length) + source clock jitter (cycle-to-cycle)⁽¹⁾ + ISI (inter-symbol interference)⁽²⁾

(1) Cycle-to-cycle jitter depends on the Tx source. Clock jitter should be maintained to less than 250 ps at 85 MHz.

(2) ISI is dependent on interconnect length; may be zero.

Figure 13. Receiver LVDS Input Skew Margin

6.8 Typical Characteristics

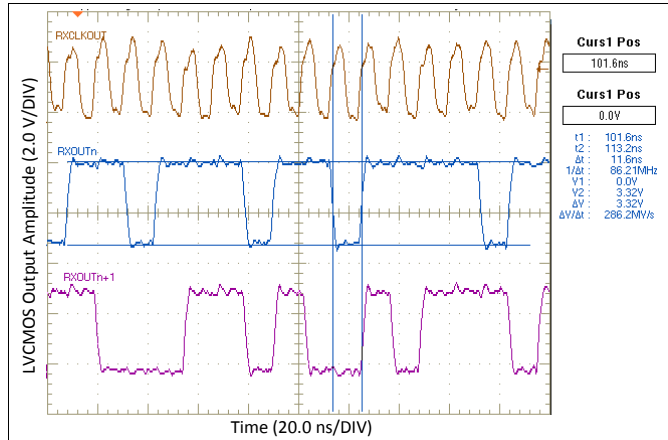

Figure 14. Parallel PRBS-7 on LVC MOS Outputs at 85 MHz

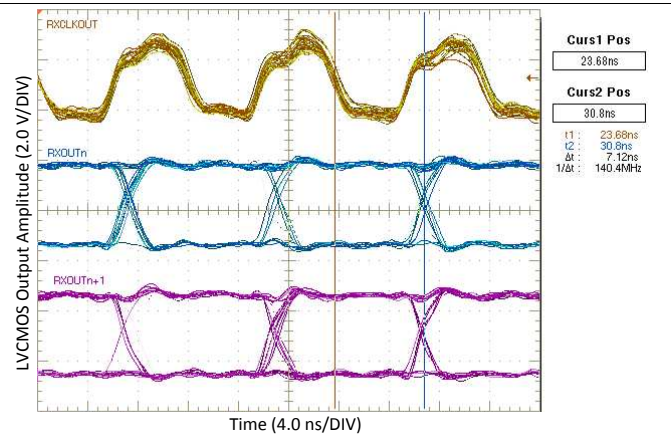

Figure 15. Typical RxOUT Strobe Position at 85 MHz

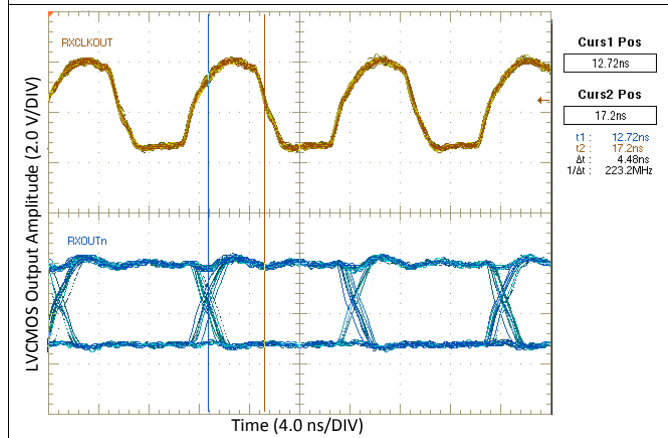

Figure 16. Typical RxOUT Setup Time at 85 MHz (RSRC = 4.5 ns)

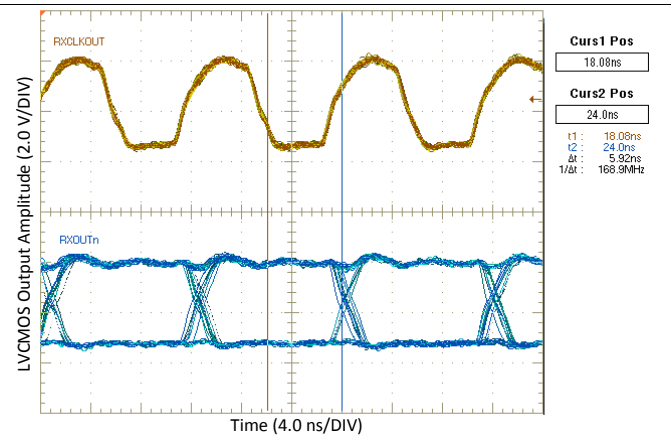

Figure 17. Typical RxOUT Hold Time at 85 MHz (RHRC = 5.9 ns)

7 Detailed Description

7.1 Overview

The DS90CF386 is a receiver that converts four LVDS (Low Voltage Differential Signaling) data streams into parallel 28 bits of LVCMOS data (24 bits of RGB and 4 bits of HSYNC, VSYNC, DE, and CNTL). The DS90CF366 is a receiver that converts three LVDS data streams into parallel 21 bits of LVCMOS data (18 bits of RGB and 3 bits of HSYNC, VSYNC, and DE). An internal PLL locks to the incoming LVDS clock ranging from 20 to 85 MHz. The locked PLL ensures a stable clock to sample the output LVCMOS data on the Receiver Clock Out falling edge. These devices feature a PWR DWN pin to put the device into low power mode when there is no active input data.

7.2 Functional Block Diagrams

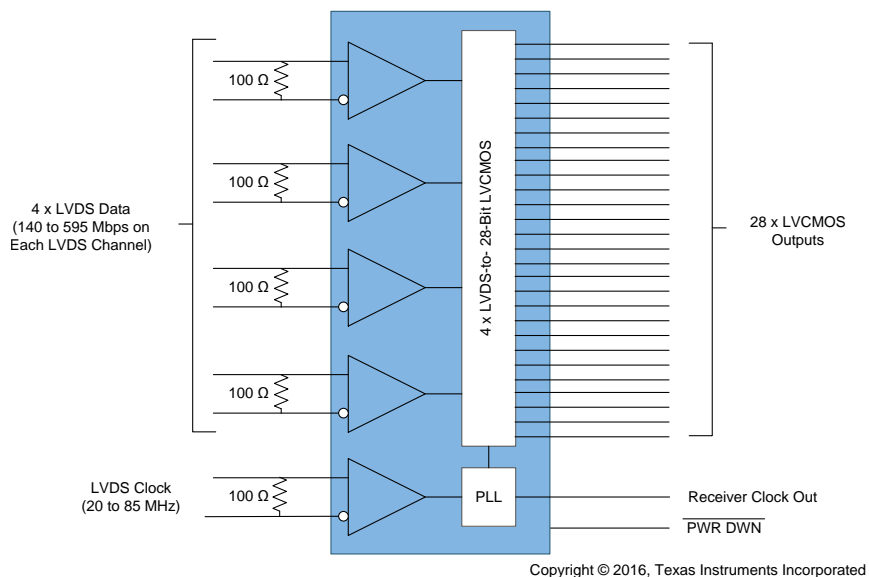

Figure 18. DS90CF386 Block Diagram

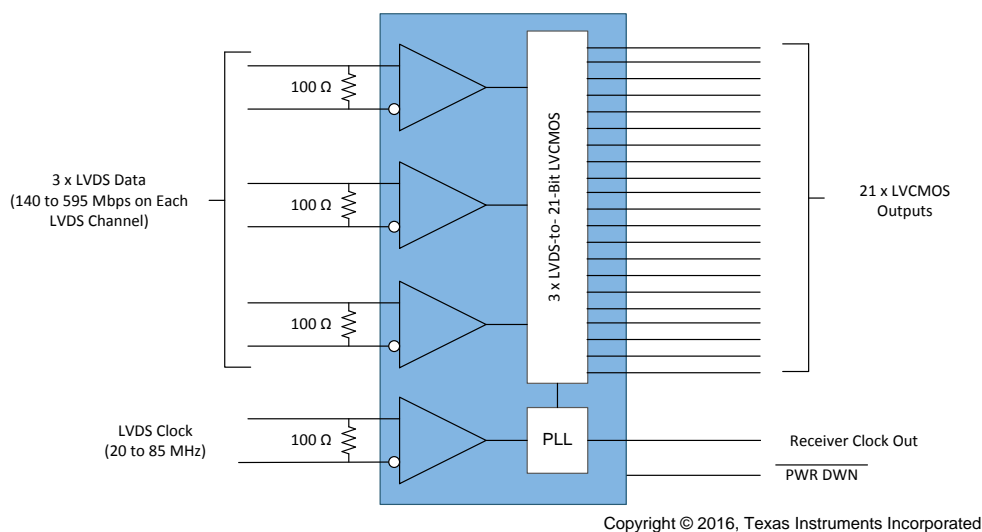

Figure 19. DS90CF366 Block Diagram

7.3 Feature Description

The DS90CF386 and DS90CF366 consist of several key blocks:

- LVDS Receivers
- Phase Locked Loop (PLL)
- Serial LVDS-to-Parallel LVCMOS Converter
- LVCMOS Drivers

7.3.1 LVDS Receivers

There are five differential LVDS inputs to the DS90CF386 and four differential LVDS inputs to the DS90CF366. For the DS90CF386, four of the LVDS inputs contain serialized data originating from a 28-bit source transmitter. For the DS90CF366, three of the LVDS inputs contain serialized data originating from a 21-bit source transmitter. The remaining LVDS input contains the LVDS clock associated with the data pairs.

7.3.1.1 LVDS Input Termination

The DS90CF386 and DS90CF366 require a single 100- Ω terminating resistor across the true and complement lines on each differential pair of the receiver input. To prevent reflections due to stubs, this resistor should be placed as close to the device input pins as possible. [Figure 20](#) shows an example.

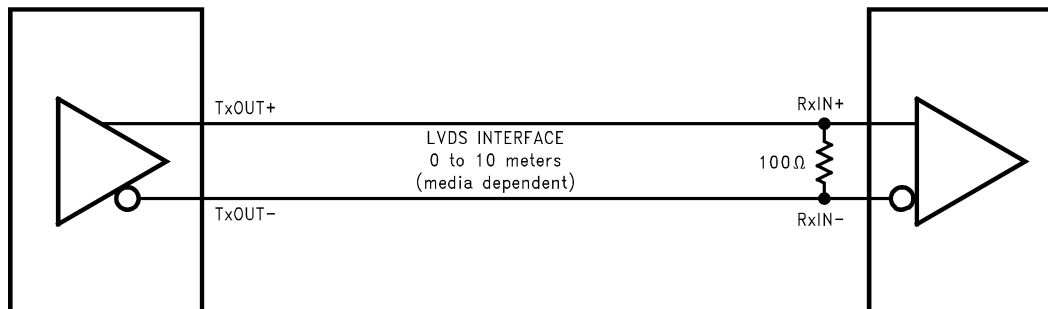

Figure 20. LVDS Serialized Link Termination

7.3.2 Phase Locked Loop (PLL)

The FPD Link I devices use an internal PLL to recover the clock transmitted across the LVDS interface. The recovered clock is then used as a reference to determine the sampling position of the seven serial bits received per clock cycle. The width of each bit in the serialized LVDS data stream is one-seventh the clock period. Differential skew (Δt within one differential pair), interconnect skew (Δt of one differential pair to another), and clock jitter will all reduce the available window for sampling the LVDS serial data streams. Individual bypassing of each V_{CC} to ground will minimize the noise passed on to the PLL, thus creating a low jitter LVDS clock to improve the overall jitter budget.

7.3.3 Serial LVDS-to-Parallel LVCMOS Converter

After the PLL locks to the incoming LVDS clock, the receiver deserializes each LVDS differential data pair into seven parallel LVCMOS data outputs per clock cycle. For the DS90CF386, the LVDS data inputs map to LVCMOS outputs according to [Figure 8](#). For the DS90CF366, the LVDS data inputs map to LVCMOS outputs according to [Figure 9](#).

7.3.4 LVCMOS Drivers

The LVCMOS outputs from the DS90CF386 and DS90CF366 are the deserialized parallel single-ended data from the serialized LVDS differential data pairs. Each LVCMOS output is clocked by the PLL and strobes on the RxCLKOUT falling edge. All unused DS90CF386 and DS90CF366 RxOUT outputs can be left floating.

7.4 Device Functional Modes

7.4.1 Power Sequencing and Power-Down Mode

The DS90CF386 and DS90CF366 may be placed into a power down mode at any time by asserting the $\overline{\text{PWR DWN}}$ pin (active low). The DS90CF386 and DS90CF366 are also designed to protect themselves from accidental loss of power to either the transmitter or receiver. If power to the transmit board is lost, the receiver clocks (input and output) stop. The data outputs (RxOUT) retain the states they were in when the clocks stopped. When the receiver board loses power, the receiver inputs are controlled by a failsafe bias circuitry. The LVDS inputs are High-Z during initial power on and power off conditions. Current is limited to 5 mA per input, thus avoiding the potential for latch-up when powering the device.

8 Application and Implementation

NOTE

Information in the following applications sections is not part of the TI component specification, and TI does not warrant its accuracy or completeness. TI's customers are responsible for determining suitability of components for their purposes. Customers should validate and test their design implementation to confirm system functionality.

8.1 Application Information

The DS90F386 and DS90CF366 are designed for a wide variety of data transmission applications. The use of serialized LVDS data lines in these applications allows for efficient signal transmission over a narrow bus width, thereby reducing cost, power, and space.

8.2 Typical Applications

Figure 21 and Figure 22 show typical applications of the DS90CF386 and DS90CF366 for displays when used as an OpenLDI-to-RGB bridge.

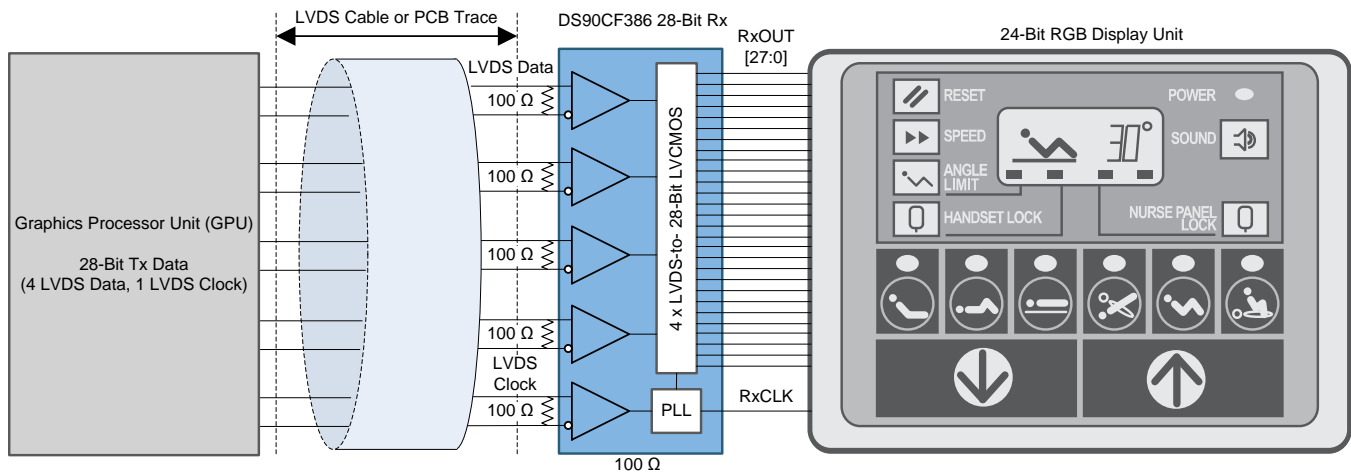

Copyright © 2016, Texas Instruments Incorporated

Figure 21. Typical DS90CF386 Application Block Diagram

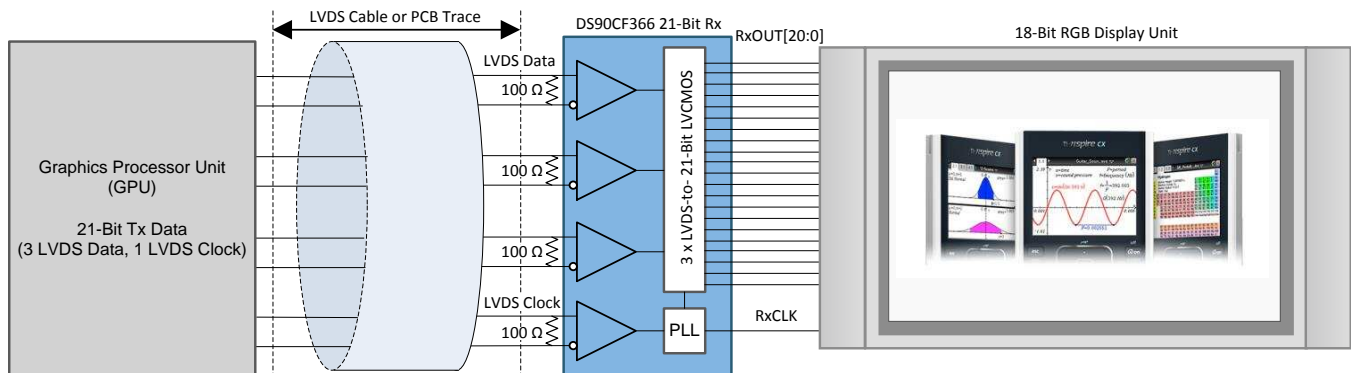

Copyright © 2016, Texas Instruments Incorporated

Figure 22. Typical DS90CF366 Application Block Diagram

Typical Applications (continued)

8.2.1 Design Requirements

For this design example, follow the requirements in [Table 1](#).

Table 1. Design Parameters

PARAMETER	DESIGN REQUIREMENTS
Operating frequency	LVDS clock must be within 20 MHz to 85 MHz.
Bit resolution	DS90CF386: No higher than 24 bpp. The maximum supported resolution is 8-bit RGB. DS90CF366: No higher than 18 bpp. The maximum supported resolution is 6-bit RGB.
Bit data mapping	Determine the appropriate mapping required by the panel display following the DS90CF386 or DS90CF366 outputs.
RSKM (Receiver skew margin)	Ensure that there is acceptable margin between Tx pulse position and Rx strobe position.
Input termination for RxIN±	Inputs require a 100 Ω ± 10% resistor across each LVDS differential pair. Place as close as possible to IC input pins.
RxIN± board trace impedance	Design differential trace impedance with 100 Ω ±5%
LVC MOS outputs	If unused, leave pins floating. Series resistance on each LVC MOS output optional to reduce reflections from long board traces. If used, 33-Ω series resistance is typical.
DC power supply coupling capacitors	Use a 0.1-μF capacitor to minimize power supply noise. Place as close as possible to V _{CC} pins.

8.2.2 Detailed Design Procedure

To design with the DS90CF386 or DS90CF366, determine the following:

- Cable Interface
- Bit Resolution and Operating Frequency
- Bit Mapping from Receiver to Endpoint Panel Display
- RSKM Interoperability with Transmitter Pulse Position Margin

8.2.2.1 Cables

A cable interface between the transmitter and receiver needs to support the differential LVDS pairs. The DS90CF366 requires four pairs of signal wires and the DS90CF386 requires five pairs of signal wires. The ideal cable interface has a constant 100-Ω differential impedance throughout the path. It is also recommended that cable skew remain below 120 ps (assuming 85 MHz clock rate) to maintain a sufficient data sampling window at the receiver.

Depending upon the application and data rate, the interconnecting media between Tx and Rx may vary. For example, for lower data rate (clock rate) and shorter cable lengths (< 2m), the media electrical performance is less critical. For higher speed or long distance applications, the media's performance becomes more critical. Certain cable constructions provide tighter skew (matched electrical length between the conductors and pairs). For example, twin-coax cables have been demonstrated at distances as long as five meters and with the maximum data transfer of 2.38 Gbps (DS90CF366) and 1.785 Gbps (DS90CF386).

8.2.2.2 Bit Resolution and Operating Frequency Compatibility

The bit resolution of the endpoint panel display reveals whether there are enough bits available in the DS90CF386 or DS90CF366 to output the required data per pixel. The DS90CF386 has 28 parallel LVC MOS outputs and can therefore provide a bit resolution up to 24 bpp (bits per pixel). In each clock cycle, the remaining bits are the three control signals (HSync, VSync, DE) and one spare bit. The DS90CF366 has 21 parallel LVC MOS outputs and can therefore provide a bit resolution up to 18 bpp (bits per pixel). In each clock cycle, the remaining bits are the three control signals (HSync, VSync, DE).

The number of pixels per frame and the refresh rate of the endpoint panel display indicate the required operating frequency of the deserializer clock. To determine the required clock frequency, refer to [Equation 1](#).

$$f_{\text{Clk}} = [H_{\text{Active}} + H_{\text{Blank}}] \times [V_{\text{Active}} + V_{\text{Blank}}] \times f_{\text{Vertical}}$$

where

- H_{Active} = Active Display Horizontal Lines

- H_Blank = Blanking Period Horizontal Lines
 - V_Active = Active Display Vertical Lines
 - V_Blank = Blanking Period Vertical Lines
 - f_Vertical = Refresh Rate (in Hz)
 - f_Clk = Operating Frequency of LVDS clock
- (1)

In each frame, there is a blanking period associated with horizontal rows and vertical columns that are not actively displayed on the panel. These blanking period pixels must be included to determine the required clock frequency. Consider the following example to determine the required LVDS clock frequency:

- H_Active = 640
- H_Blank = 40
- V_Active = 480
- V_Blank = 41
- f_Vertical = 59.95 Hz

Thus, the required operating frequency is determined with [Equation 2](#).

$$[640 + 40] \times [480 + 41] \times 59.95 = 21239086 \text{ Hz} \approx 21.24 \text{ MHz} \quad (2)$$

Since the operating frequency for the PLL in the DS90CF386 and DS90CF366 ranges from 20 to 85 MHz, the DS90CF386 and DS90CF366 can support a panel display with the aforementioned requirements.

If the specific blanking interval is unknown, the number of pixels in the blanking interval can be approximated to 20% of the active pixels. [Equation 3](#) can be used as a conservative approximation for the operating LVDS clock frequency:

$$f_{\text{Clk}} \approx H_{\text{Active}} \times V_{\text{Active}} \times f_{\text{Vertical}} \times 1.2 \quad (3)$$

Using this approximation, the operating frequency for the example in this section is estimated with [Equation 4](#).

$$640 \times 480 \times 59.95 \times 1.2 = 22099968 \text{ Hz} \approx 22.10 \text{ MHz} \quad (4)$$

8.2.2.3 Data Mapping between Receiver and Endpoint Panel Display

Ensure that the LVCMOS outputs are mapped to align with the endpoint display RGB mapping requirements following the deserializer. See the following for two popular mapping topologies for 8-bit RGB data.

1. LSBs are mapped to RxIN3±.
2. MSBs are mapped to RxIN3±.

[Table 2](#) and [Table 3](#) depict how these two popular topologies can be mapped to the DS90CF386 outputs.

Table 2. 8-Bit Color Mapping with LSBs on RxIN3±

LVDS INPUT CHANNEL	LVDS BIT STREAM POSITION	LVCMOS OUTPUT CHANNEL	COLOR MAPPING	COMMENTS
RxIN0	TxIN0	RxOUT0	R2	
	TxIN1	RxOUT1	R3	
	TxIN2	RxOUT2	R4	
	TxIN3	RxOUT3	R5	
	TxIN4	RxOUT4	R6	
	TxIN6	RxOUT6	R7	MSB
RxIN1	TxIN7	RxOUT7	G2	
	TxIN8	RxOUT8	G3	
	TxIN9	RxOUT9	G4	
	TxIN12	RxOUT12	G5	
	TxIN13	RxOUT13	G6	
	TxIN14	RxOUT14	G7	MSB
	TxIN15	RxOUT15	B2	
	TxIN18	RxOUT18	B3	

Table 2. 8-Bit Color Mapping with LSBs on RxIN3± (continued)

LVDS INPUT CHANNEL	LVDS BIT STREAM POSITION	LVC MOS OUTPUT CHANNEL	COLOR MAPPING	COMMENTS
RxIN2	TxIN19	RxOUT19	B4	
	TxIN20	RxOUT20	B5	
	TxIN21	RxOUT21	B6	
	TxIN22	RxOUT22	B7	MSB
	TxIN24	RxOUT24	HSYNC	Horizontal sync
	TxIN25	RxOUT25	VSYNC	Vertical sync
	TxIN26	RxOUT26	DE	Data enable
RxIN3	TxIN27	RxOUT27	R0	LSB
	TxIN5	RxOUT5	R1	
	TxIN10	RxOUT10	G0	LSB
	TxIN11	RxOUT11	G1	
	TxIN16	RxOUT16	B0	LSB
	TxIN17	RxOUT17	B1	
	TxIN23	RxOUT23	GP	General purpose

Table 3. 8-Bit Color Mapping with MSBs on RxIN3±

LVDS INPUT CHANNEL	LVDS BIT STREAM POSITION	LVC MOS OUTPUT CHANNEL	COLOR MAPPING	COMMENTS
RxIN0	TxIN0	RxOUT0	R0	LSB
	TxIN1	RxOUT1	R1	
	TxIN2	RxOUT2	R2	
	TxIN3	RxOUT3	R3	
	TxIN4	RxOUT4	R4	
	TxIN6	RxOUT6	R5	
RxIN1	TxIN7	RxOUT7	G0	LSB
	TxIN8	RxOUT8	G1	
	TxIN9	RxOUT9	G2	
	TxIN12	RxOUT12	G3	
	TxIN13	RxOUT13	G4	
	TxIN14	RxOUT14	G5	
	TxIN15	RxOUT15	B0	LSB
RxIN2	TxIN18	RxOUT18	B1	
	TxIN19	RxOUT19	B2	
	TxIN20	RxOUT20	B3	
	TxIN21	RxOUT21	B4	
	TxIN22	RxOUT22	B5	
	TxIN24	RxOUT24	HSYNC	Horizontal sync
	TxIN25	RxOUT25	VSYNC	Vertical sync
RxIN3	TxIN26	RxOUT26	DE	Data enable
	TxIN27	RxOUT27	R6	
	TxIN5	RxOUT5	R7	MSB
	TxIN10	RxOUT10	G6	
	TxIN11	RxOUT11	G7	MSB
	TxIN16	RxOUT16	B6	
	TxIN17	RxOUT17	B7	MSB
TxIN23	RxOUT23	GP	General purpose	

In the case where either DS90CF386 or DS90CF366 is used to support 18 bpp, [Table 2](#) is commonly used, where RxIN3± (if applicable) is left as *No Connect*. With this mapping, MSBs of RGB data are retained on RXIN0±, RXIN1±, and RXIN2± while the two LSBs for the original 8-bit RGB resolution are ignored from RxIN3±.

8.2.2.4 RSKM Interoperability

One of the most important factors when designing the receiver into a system application is assessing how much RSKM (Receiver Skew Margin) is available. In each LVDS clock cycle, the LVDS data stream carries seven serialized data bits. Ideally, the Transmit Pulse Position for each bit will occur every $(n \times T)/7$ seconds, where $n = \text{Bit Position}$ and $T = \text{LVDS Clock Period}$. Likewise, ideally the Rx Strobe Position for each bit will occur every $((n + 0.5) \times T)/7$ seconds. However, in real systems, both LVDS Tx and Rx will have non-ideal pulse and strobe position for each bit position due to the effects of cable skew, clock jitter, and ISI. This concept is illustrated in [Figure 23](#).

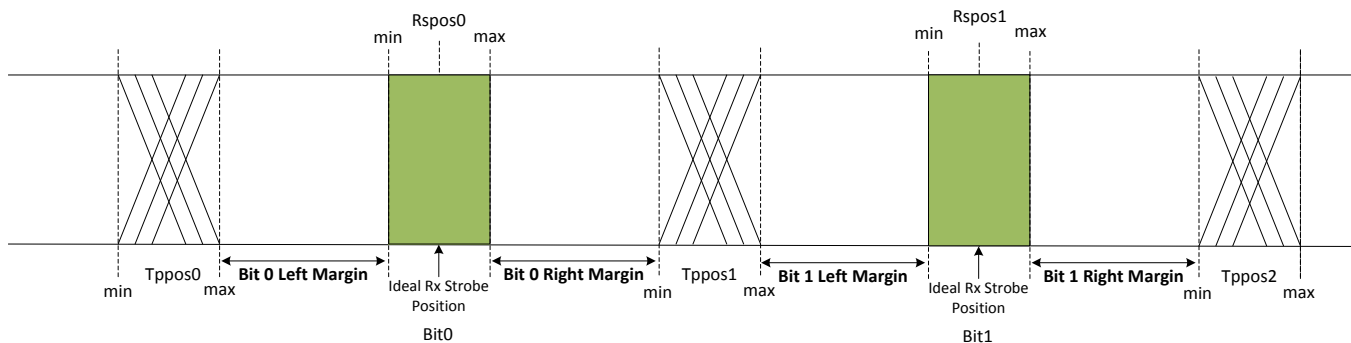

Figure 23. RSKM Measurement Example

All left and right margins for Bits 0-6 must be considered in order to determine the absolute minimum for the whole LVDS bit stream. This absolute minimum corresponds to the RSKM.

To improve RSKM performance between LVDS transmitter and receiver, designers often either advance or delay the LVDS clock compared to the LVDS data. Moving the LVDS clock compared to the LVDS data can improve the location of the setup and hold time for the transmitter compared to the setup and hold time for the receiver.

If there is less left bit margin than right bit margin, the LVDS clock can be delayed so that the Rx strobe position for incoming data appears to be delayed. If there is less right bit margin than left bit margin, all the LVDS data pairs can be delayed uniformly so that the LVDS clock and Rx strobe position for incoming data appear to advance. To delay an LVDS data or clock pair, designers either add more PCB trace length or install a capacitor between the LVDS transmitter and receiver. It is important to note that when using these techniques, all serialized bit positions are shifted right or left uniformly.

When designing the DS90CF386 or DS90CF366 receiver with a third-party OpenLDI transmitter, users must calculate the skew margin budget (RSKM) based on the Tx pulse position and the Rx strobe position to ensure error-free transmission. For more information about calculating RSKM, refer to Application Note, [Receiver Skew Margin for Channel Link I and FPD Link I Devices \(SNLA249\)](#).

8.2.3 Application Curves

The following application curves are examples taken with a DS90C385A serializer interfacing to a DS90CF386 deserializer with nominal temperature (25°C) and voltage supply (3.3 V) at an operating frequency of 85 MHz.

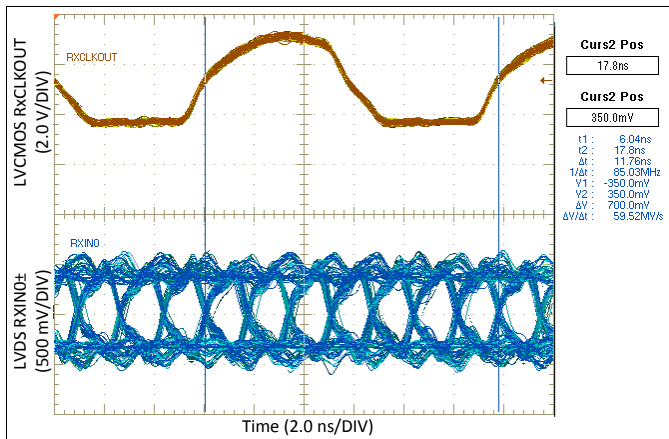

Figure 24. LVDS RxIN0± Aligned With LVCMOS RxCLKOUT

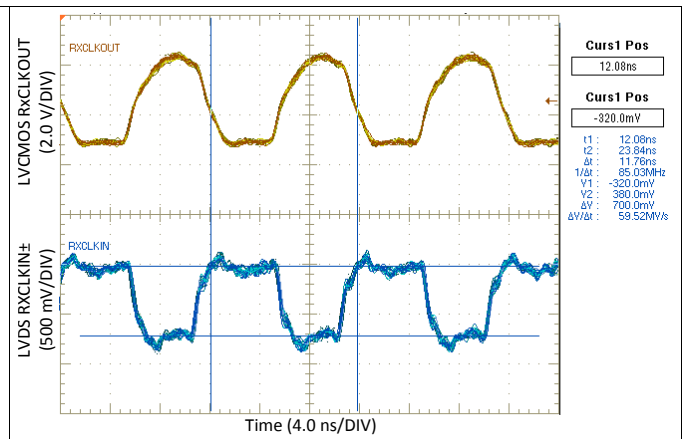

Figure 25. LVDS CLKIN Aligned With LVCMOS RxCLKOUT

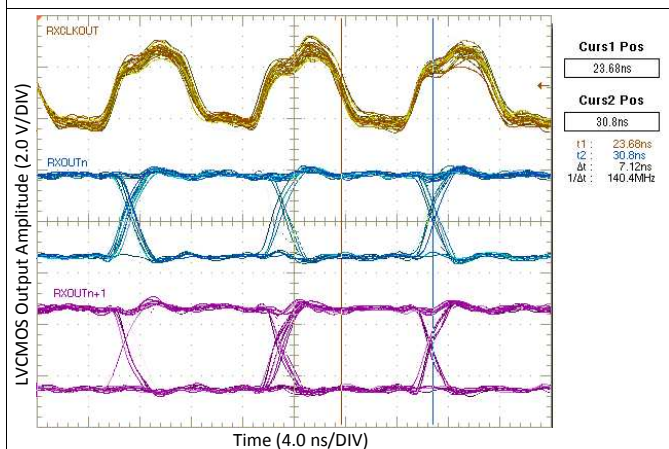

Figure 26. RxOUT Strobe on Falling Edge Of RxCLKOUT

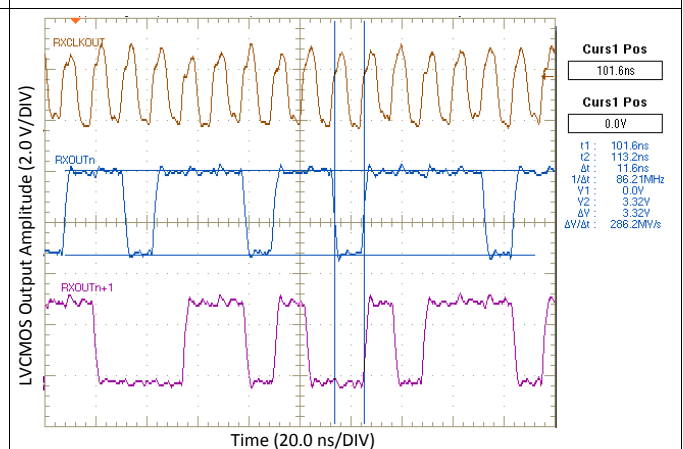

Figure 27. PRBS-7 Output On RxOUT Channels

9 Power Supply Recommendations

Proper power supply decoupling is important to ensure a stable power supply with minimal power supply noise. Bypassing capacitors are needed to reduce the impact of switching noise which could limit performance. For a conservative approach, three parallel-connected decoupling capacitors (multi-layered ceramic type in surface mount form factor) between each V_{CC} (V_{CC} , PLL V_{CC} , LVDS V_{CC}) and the ground plane(s) are recommended. The three capacitor values are $0.1\ \mu\text{F}$, $0.01\ \mu\text{F}$, and $0.001\ \mu\text{F}$. The preferred capacitor size is 0402. An example is shown in Figure 28. The designer should employ wide traces for power and ground and ensure each capacitor has its own via to the ground plane. This helps to reduce overall inductance with regards to power supply filtering. If board space is limiting the number of bypass capacitors, the PLL V_{CC} should receive the most filtering. Next would be the LVDS V_{CC} pins and finally the logic V_{CC} pins.

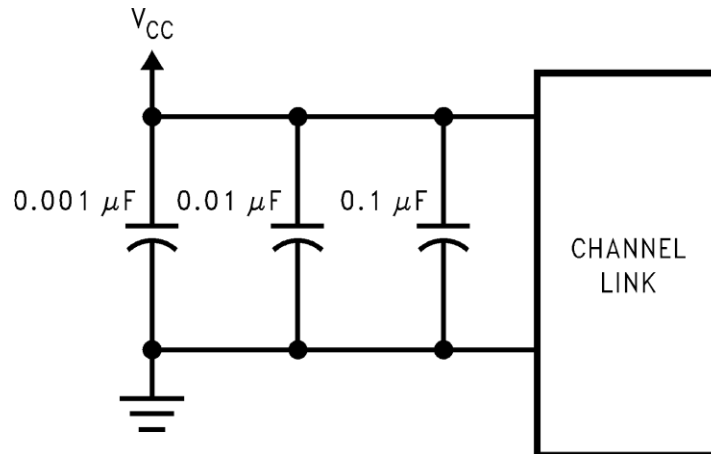

Figure 28. Recommended Bypass Capacitor Decoupling Configuration for V_{CC} , PLL V_{CC} , and LVDS V_{CC}

10 Layout

10.1 Layout Guidelines

As with any high speed design, board designers must maximize signal integrity by limiting reflections and crosstalk that can adversely affect high frequency and EMI performance. The following practices are recommended layout guidelines to optimize device performance.

- Ensure that differential pair traces are always closely coupled to eliminate noise interference from other signals and take full advantage of the common mode noise canceling effect of the differential signals.
- Maintain equal length on signal traces for a given differential pair.
- Limit impedance discontinuities by reducing the number of vias on signal traces.
- Eliminate any 90° angles on traces and use 45° bends instead.
- If a via must exist on one signal polarity, mirror the via implementation on the other polarity of the differential pair.
- Match the differential impedance of the selected physical media. This impedance should also match the value of the termination resistor that is connected across the differential pair at the receiver's input.
- When possible, use short traces for LVDS inputs.

10.2 Layout Examples

The following images show an example layout of the DS90CF386. Traces in blue correspond to the top layer and the traces in green correspond to the bottom layer. Note that differential pair inputs to the DS90CF386 are tightly coupled and close to the connector pins. In addition, observe that the power supply decoupling capacitors are placed as close as possible to the power supply pins with through vias in order to minimize inductance. The principles illustrated in this layout can also be applied to the 48-pin DS90CF366.

Layout Examples (continued)

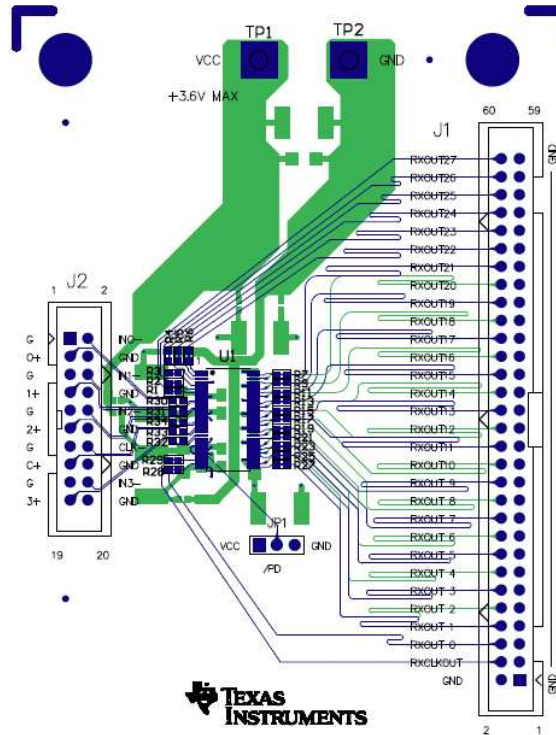

Figure 29. Example Layout With DS90CF386 (U1)

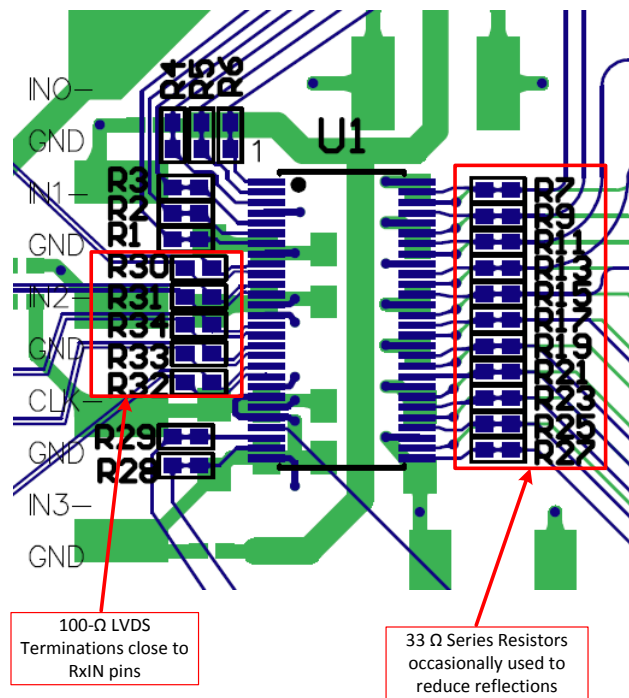

Figure 30. Example Layout Close-Up

11 Device and Documentation Support

11.1 Documentation Support

11.1.1 Related Documentation

For related documentation see the following:

- Application Note, *Receiver Skew Margin for Channel Link I and FPD Link I Devices*, [SNLA249](#)

11.2 Community Resources

The following links connect to TI community resources. Linked contents are provided "AS IS" by the respective contributors. They do not constitute TI specifications and do not necessarily reflect TI's views; see TI's [Terms of Use](#).

TI E2E™ Online Community *TI's Engineer-to-Engineer (E2E) Community*. Created to foster collaboration among engineers. At [e2e.ti.com](#), you can ask questions, share knowledge, explore ideas and help solve problems with fellow engineers.

Design Support *TI's Design Support* Quickly find helpful E2E forums along with design support tools and contact information for technical support.

11.3 Trademarks

E2E is a trademark of Texas Instruments.
All other trademarks are the property of their respective owners.

11.4 Electrostatic Discharge Caution



These devices have limited built-in ESD protection. The leads should be shorted together or the device placed in conductive foam during storage or handling to prevent electrostatic damage to the MOS gates.

11.5 Glossary

[SLYZ022](#) — *TI Glossary*.

This glossary lists and explains terms, acronyms, and definitions.

12 Mechanical, Packaging, and Orderable Information

The following pages include mechanical, packaging, and orderable information. This information is the most current data available for the designated devices. This data is subject to change without notice and revision of this document. For browser-based versions of this data sheet, refer to the left-hand navigation.

PACKAGING INFORMATION

Orderable part number	Status (1)	Material type (2)	Package Pins	Package qty Carrier	RoHS (3)	Lead finish/ Ball material (4)	MSL rating/ Peak reflow (5)	Op temp (°C)	Part marking (6)
DS90CF366MTD/NOPB	Active	Production	TSSOP (DGG) 48	38 TUBE	Yes	SN	Level-2-260C-1 YEAR	-10 to 70	DS90CF366MTD >B
DS90CF366MTD/NOPB.A	Active	Production	TSSOP (DGG) 48	38 TUBE	Yes	SN	Level-2-260C-1 YEAR	-10 to 70	DS90CF366MTD >B
DS90CF366MTD/NOPB.B	Active	Production	TSSOP (DGG) 48	38 TUBE	-	Call TI	Call TI	-10 to 70	
DS90CF366MTDX/NOPB	Active	Production	TSSOP (DGG) 48	1000 LARGE T&R	Yes	SN	Level-2-260C-1 YEAR	-10 to 70	DS90CF366MTD >B
DS90CF366MTDX/NOPB.A	Active	Production	TSSOP (DGG) 48	1000 LARGE T&R	Yes	SN	Level-2-260C-1 YEAR	-10 to 70	DS90CF366MTD >B
DS90CF366MTDX/NOPB.B	Active	Production	TSSOP (DGG) 48	1000 LARGE T&R	-	Call TI	Call TI	-10 to 70	
DS90CF386MTD/NOPB	Active	Production	TSSOP (DGG) 56	34 TUBE	Yes	SN	Level-2-260C-1 YEAR	-10 to 70	DS90CF386MTD >B
DS90CF386MTD/NOPB.A	Active	Production	TSSOP (DGG) 56	34 TUBE	Yes	SN	Level-2-260C-1 YEAR	-10 to 70	DS90CF386MTD >B
DS90CF386MTD/NOPB.B	Active	Production	TSSOP (DGG) 56	34 TUBE	-	Call TI	Call TI	-10 to 70	
DS90CF386MTDX/NOPB	Active	Production	TSSOP (DGG) 56	1000 LARGE T&R	Yes	SN	Level-2-260C-1 YEAR	-10 to 70	DS90CF386MTD >B
DS90CF386MTDX/NOPB.A	Active	Production	TSSOP (DGG) 56	1000 LARGE T&R	Yes	SN	Level-2-260C-1 YEAR	-10 to 70	DS90CF386MTD >B
DS90CF386MTDX/NOPB.B	Active	Production	TSSOP (DGG) 56	1000 LARGE T&R	-	Call TI	Call TI	-10 to 70	
DS90CF386SLC/NOPB	Active	Production	NFBGA (NZC) 64	360 JEDEC TRAY (10+1)	Yes	SNAGCU	Level-4-260C-72 HR	-10 to 70	DS90CF386 SLC >B
DS90CF386SLC/NOPB.A	Active	Production	NFBGA (NZC) 64	360 JEDEC TRAY (10+1)	Yes	SNAGCU	Level-4-260C-72 HR	-10 to 70	DS90CF386 SLC >B
DS90CF386SLCX/NOPB	Active	Production	NFBGA (NZC) 64	2000 LARGE T&R	Yes	SNAGCU	Level-4-260C-72 HR	-10 to 70	DS90CF386 SLC >B
DS90CF386SLCX/NOPB.A	Active	Production	NFBGA (NZC) 64	2000 LARGE T&R	Yes	SNAGCU	Level-4-260C-72 HR	-10 to 70	DS90CF386 SLC >B

(1) **Status:** For more details on status, see our [product life cycle](#).

- (2) **Material type:** When designated, preproduction parts are prototypes/experimental devices, and are not yet approved or released for full production. Testing and final process, including without limitation quality assurance, reliability performance testing, and/or process qualification, may not yet be complete, and this item is subject to further changes or possible discontinuation. If available for ordering, purchases will be subject to an additional waiver at checkout, and are intended for early internal evaluation purposes only. These items are sold without warranties of any kind.
- (3) **RoHS values:** Yes, No, RoHS Exempt. See the [TI RoHS Statement](#) for additional information and value definition.
- (4) **Lead finish/Ball material:** Parts may have multiple material finish options. Finish options are separated by a vertical ruled line. Lead finish/Ball material values may wrap to two lines if the finish value exceeds the maximum column width.
- (5) **MSL rating/Peak reflow:** The moisture sensitivity level ratings and peak solder (reflow) temperatures. In the event that a part has multiple moisture sensitivity ratings, only the lowest level per JEDEC standards is shown. Refer to the shipping label for the actual reflow temperature that will be used to mount the part to the printed circuit board.
- (6) **Part marking:** There may be an additional marking, which relates to the logo, the lot trace code information, or the environmental category of the part.

Multiple part markings will be inside parentheses. Only one part marking contained in parentheses and separated by a "~" will appear on a part. If a line is indented then it is a continuation of the previous line and the two combined represent the entire part marking for that device.

Important Information and Disclaimer: The information provided on this page represents TI's knowledge and belief as of the date that it is provided. TI bases its knowledge and belief on information provided by third parties, and makes no representation or warranty as to the accuracy of such information. Efforts are underway to better integrate information from third parties. TI has taken and continues to take reasonable steps to provide representative and accurate information but may not have conducted destructive testing or chemical analysis on incoming materials and chemicals. TI and TI suppliers consider certain information to be proprietary, and thus CAS numbers and other limited information may not be available for release.

In no event shall TI's liability arising out of such information exceed the total purchase price of the TI part(s) at issue in this document sold by TI to Customer on an annual basis.

TAPE AND REEL INFORMATION

QUADRANT ASSIGNMENTS FOR PIN 1 ORIENTATION IN TAPE



*All dimensions are nominal

Device	Package Type	Package Drawing	Pins	SPQ	Reel Diameter (mm)	Reel Width W1 (mm)	A0 (mm)	B0 (mm)	K0 (mm)	P1 (mm)	W (mm)	Pin1 Quadrant
DS90CF366MTDX/NOPB	TSSOP	DGG	48	1000	330.0	24.4	8.6	13.2	1.6	12.0	24.0	Q1
DS90CF386MTDX/NOPB	TSSOP	DGG	56	1000	330.0	24.4	8.6	14.5	1.8	12.0	24.0	Q1
DS90CF386SLCX/NOPB	NFBGA	NZC	64	2000	330.0	16.4	8.3	8.3	2.3	12.0	16.0	Q1

TAPE AND REEL BOX DIMENSIONS

*All dimensions are nominal

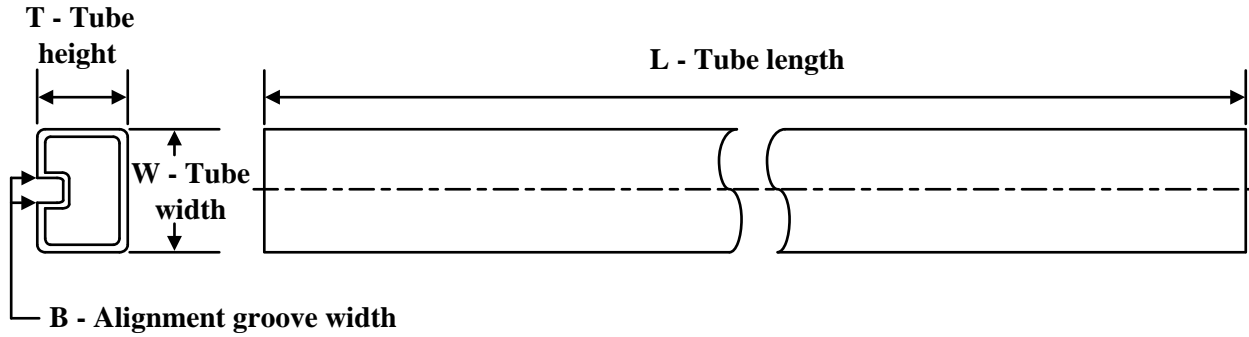
Device	Package Type	Package Drawing	Pins	SPQ	Length (mm)	Width (mm)	Height (mm)
DS90CF366MTDX/NOPB	TSSOP	DGG	48	1000	356.0	356.0	45.0
DS90CF386MTDX/NOPB	TSSOP	DGG	56	1000	356.0	356.0	45.0
DS90CF386SLCX/NOPB	NFBGA	NZC	64	2000	356.0	356.0	36.0

TUBE

*All dimensions are nominal

Device	Package Name	Package Type	Pins	SPQ	L (mm)	W (mm)	T (μm)	B (mm)
DS90CF366MTD/NOPB	DGG	TSSOP	48	38	495	10	2540	5.79
DS90CF366MTD/NOPB.A	DGG	TSSOP	48	38	495	10	2540	5.79
DS90CF386MTD/NOPB	DGG	TSSOP	56	34	495	10	2540	5.79
DS90CF386MTD/NOPB.A	DGG	TSSOP	56	34	495	10	2540	5.79

TRAY

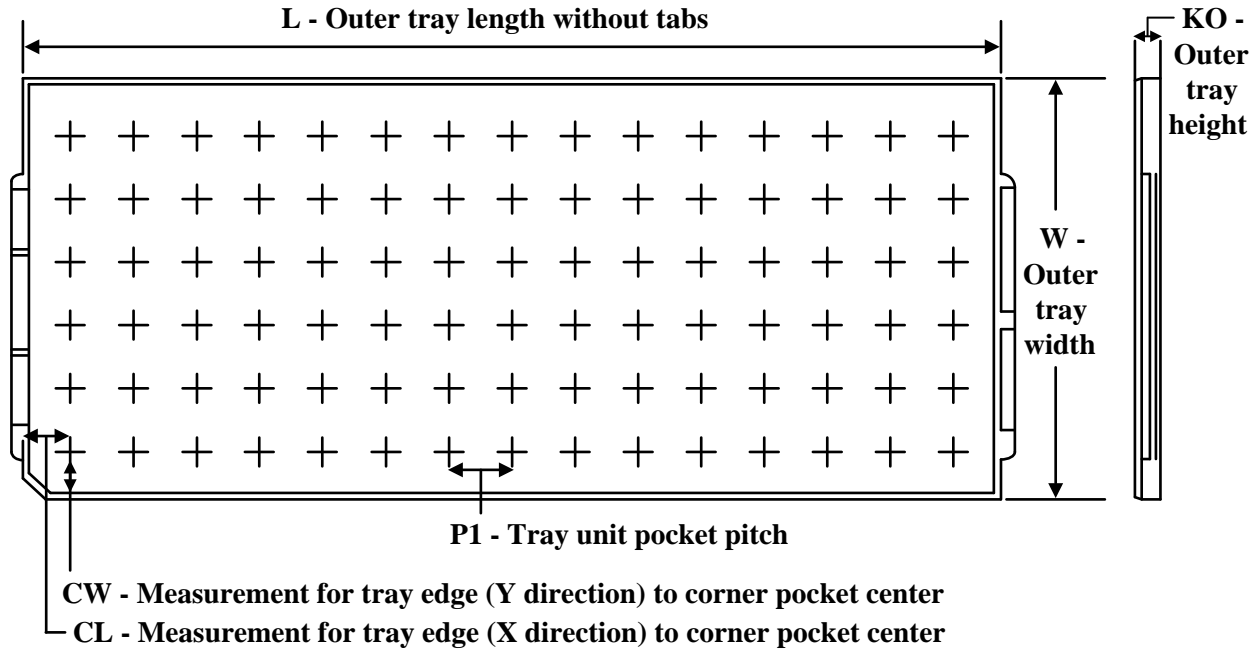

Chamfer on Tray corner indicates Pin 1 orientation of packed units.

*All dimensions are nominal

Device	Package Name	Package Type	Pins	SPQ	Unit array matrix	Max temperature (°C)	L (mm)	W (mm)	K0 (µm)	P1 (mm)	CL (mm)	CW (mm)
DS90CF386SLC/NOPB	NZC	NFBGA	64	360	12 x 30	150	322.6	135.9	7620	10	12.5	12.95
DS90CF386SLC/NOPB.A	NZC	NFBGA	64	360	12 x 30	150	322.6	135.9	7620	10	12.5	12.95

NZC0064A

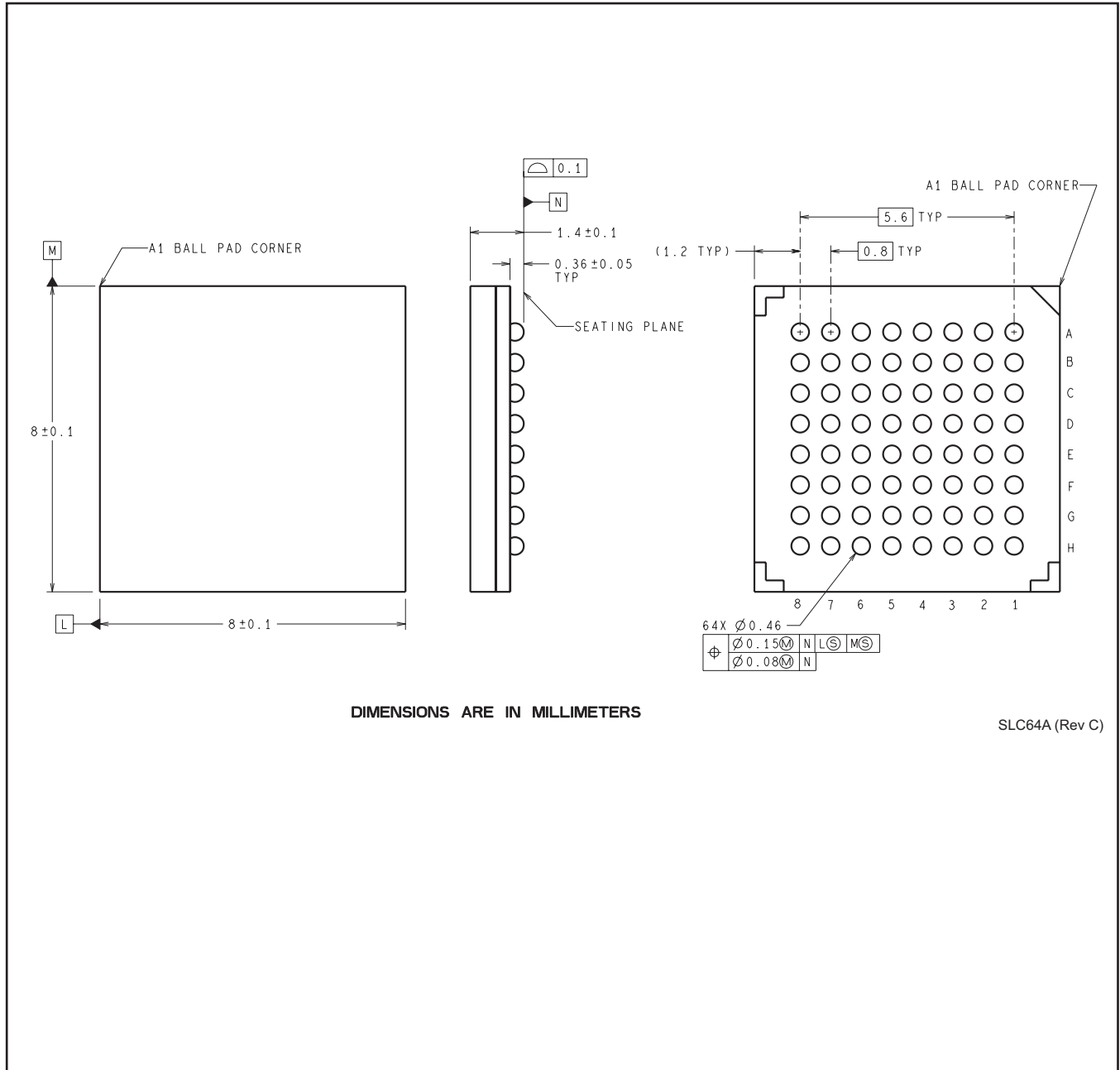

DIMENSIONS ARE IN MILLIMETERS

SLC64A (Rev C)

DGG0056A



PACKAGE OUTLINE

TSSOP - 1.2 mm max height

SMALL OUTLINE PACKAGE

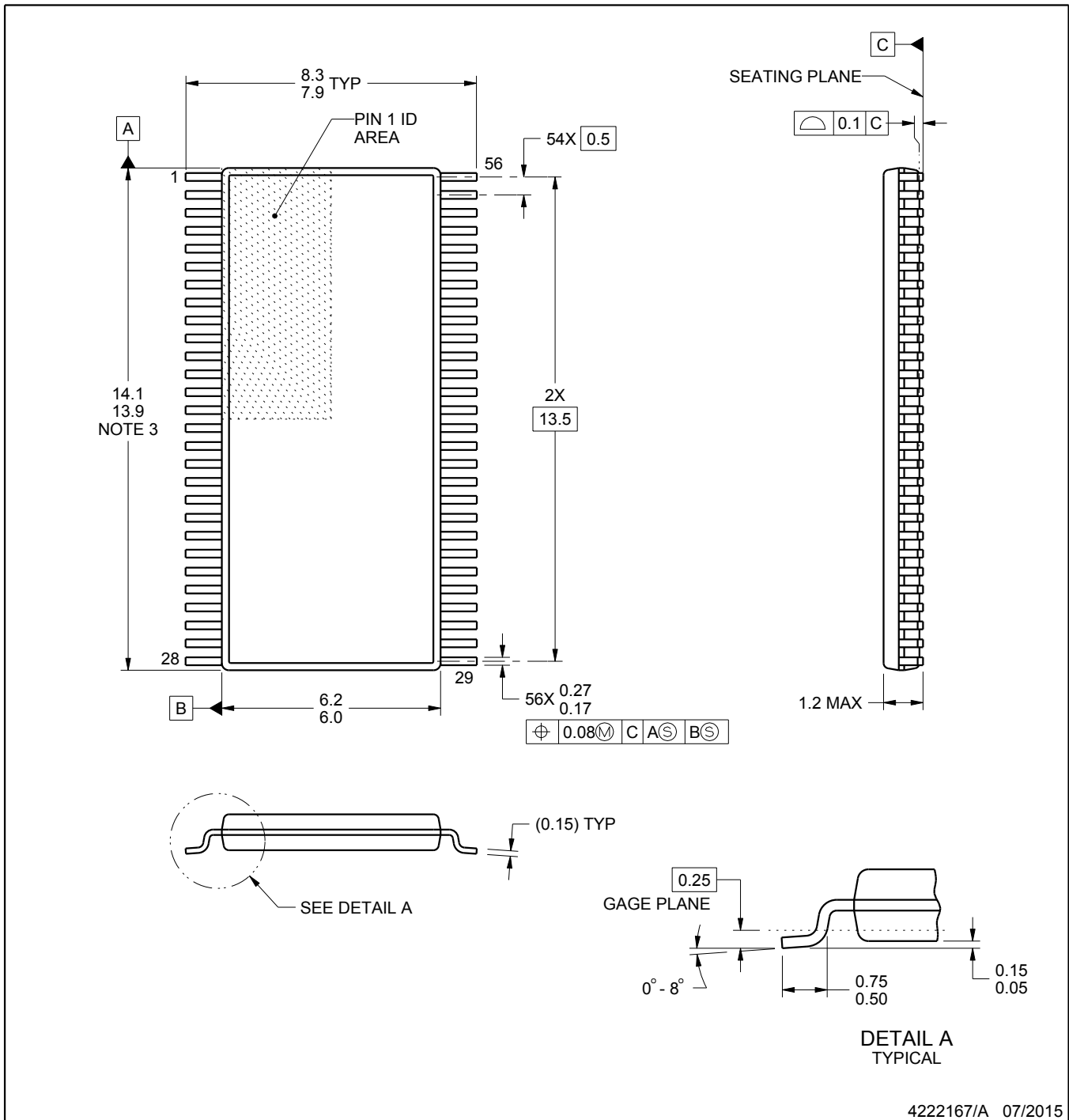

4222167/A 07/2015

NOTES:

- All linear dimensions are in millimeters. Any dimensions in parenthesis are for reference only. Dimensioning and tolerancing per ASME Y14.5M.
- This drawing is subject to change without notice.
- This dimension does not include mold flash, protrusions, or gate burrs. Mold flash, protrusions, or gate burrs shall not exceed 0.15 mm per side.
- Reference JEDEC registration MO-153.

EXAMPLE BOARD LAYOUT

DGG0056A

TSSOP - 1.2 mm max height

SMALL OUTLINE PACKAGE

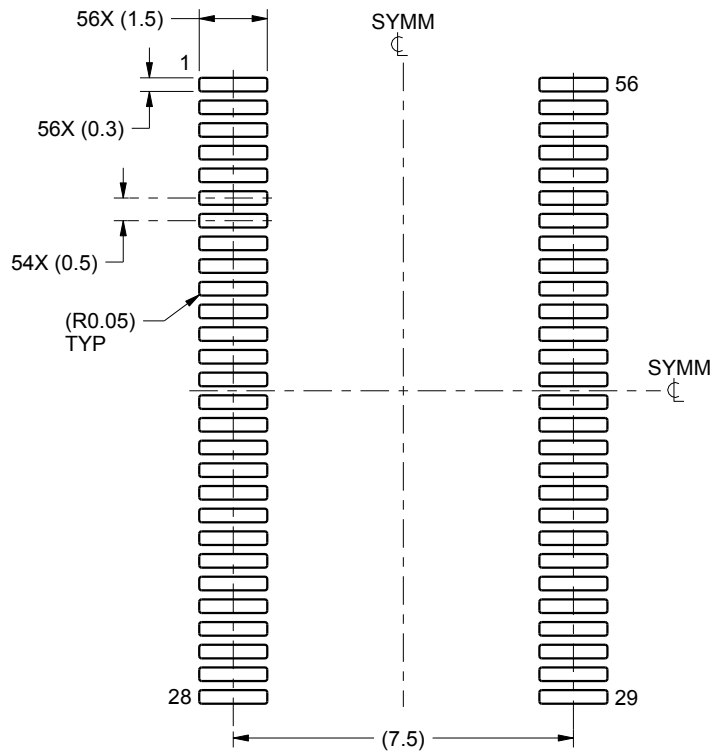

LAND PATTERN EXAMPLE
SCALE:6X

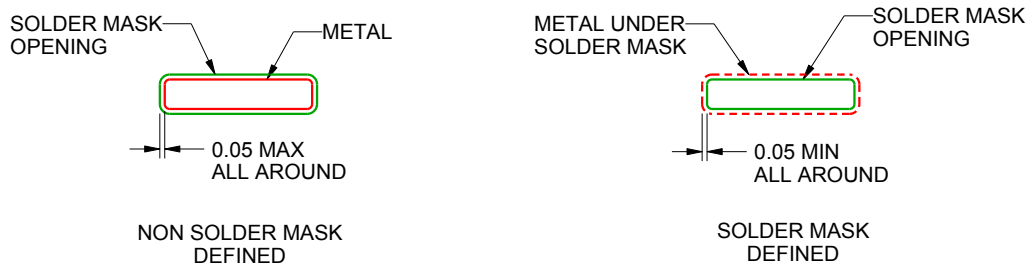

SOLDER MASK DETAILS

4222167/A 07/2015

NOTES: (continued)

- 5. Publication IPC-7351 may have alternate designs.
- 6. Solder mask tolerances between and around signal pads can vary based on board fabrication site.

EXAMPLE STENCIL DESIGN

DGG0056A

TSSOP - 1.2 mm max height

SMALL OUTLINE PACKAGE

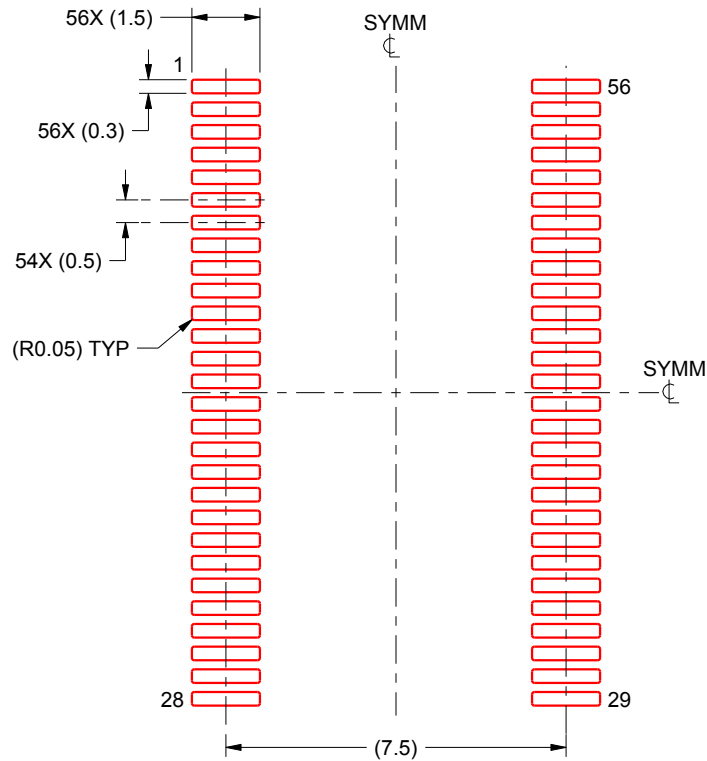

SOLDER PASTE EXAMPLE
BASED ON 0.125 mm THICK STENCIL
SCALE:6X

4222167/A 07/2015

NOTES: (continued)

7. Laser cutting apertures with trapezoidal walls and rounded corners may offer better paste release. IPC-7525 may have alternate design recommendations.
8. Board assembly site may have different recommendations for stencil design.

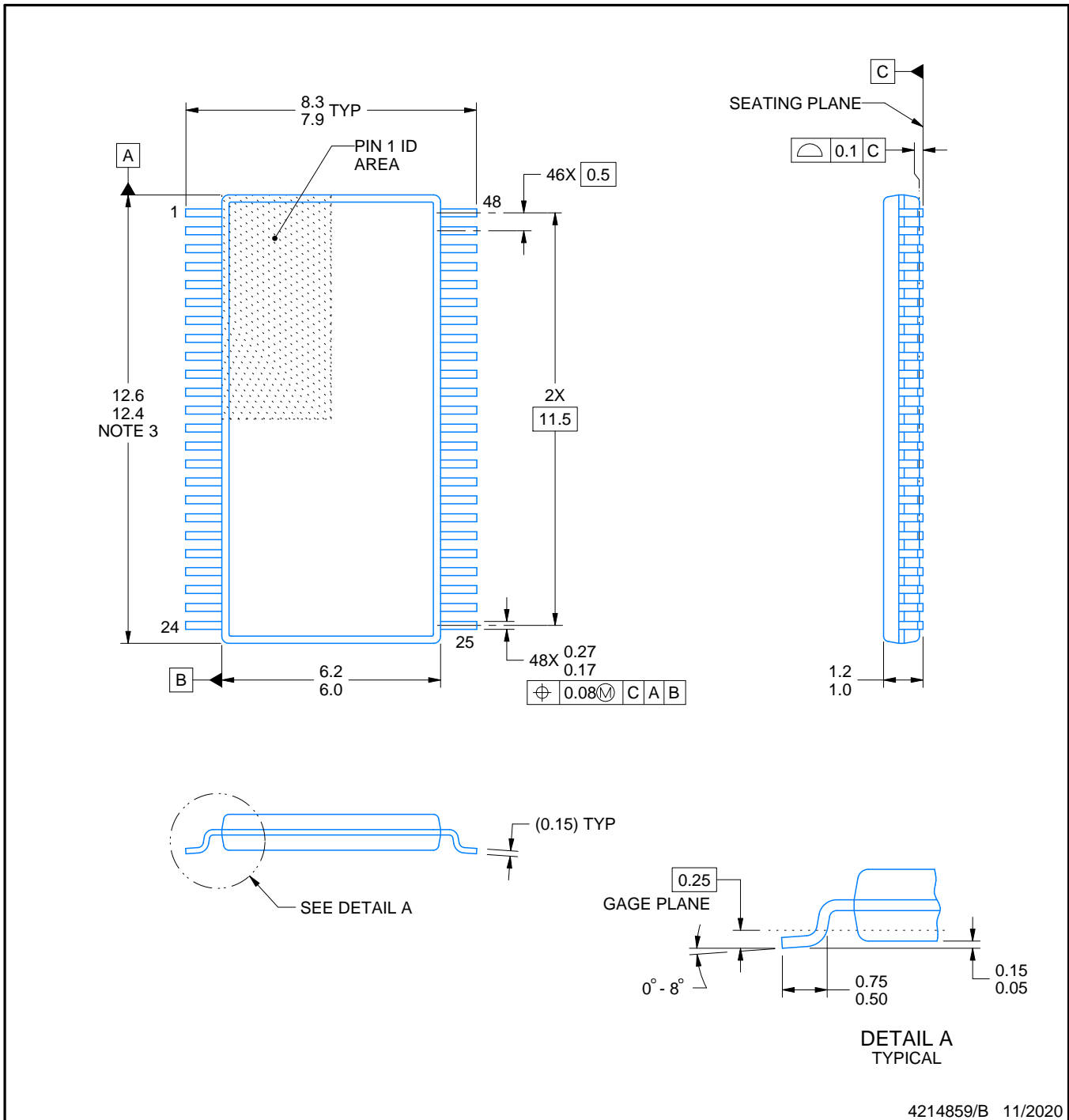
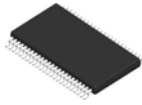

4214859/B 11/2020

NOTES:

1. All linear dimensions are in millimeters. Any dimensions in parenthesis are for reference only. Dimensioning and tolerancing per ASME Y14.5M.
2. This drawing is subject to change without notice.
3. This dimension does not include mold flash, protrusions, or gate burrs. Mold flash, protrusions, or gate burrs shall not exceed 0.15 mm per side.
4. Reference JEDEC registration MO-153.

EXAMPLE BOARD LAYOUT

DGG0048A

TSSOP - 1.2 mm max height

SMALL OUTLINE PACKAGE

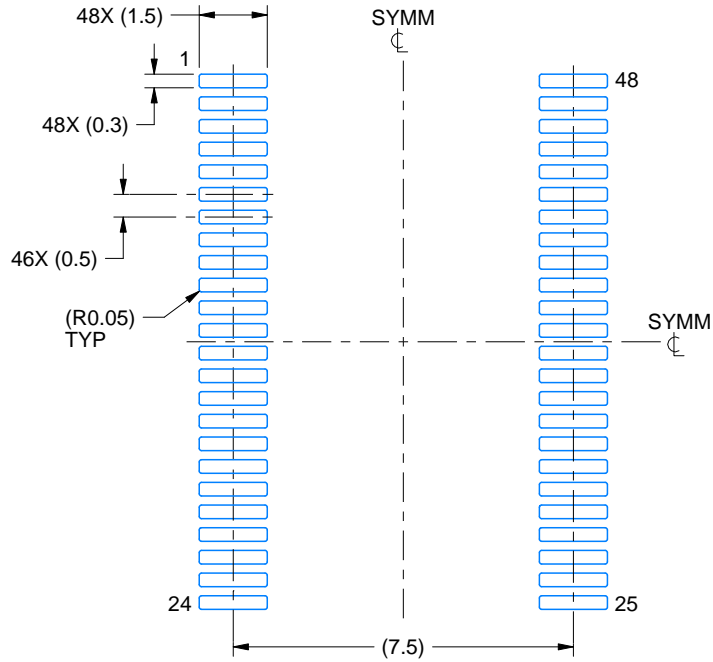

LAND PATTERN EXAMPLE
SCALE:6X

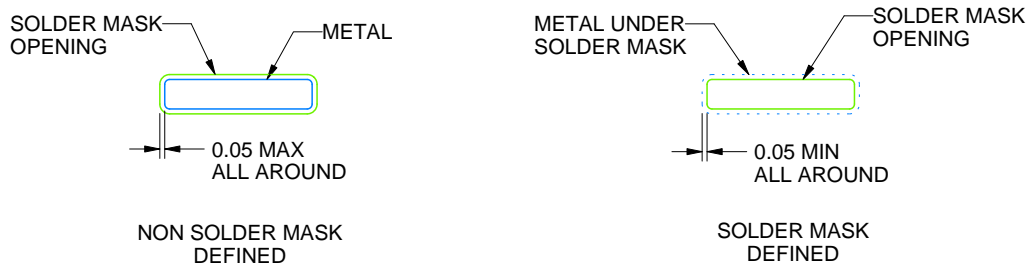

SOLDER MASK DETAILS

4214859/B 11/2020

NOTES: (continued)

5. Publication IPC-7351 may have alternate designs.
6. Solder mask tolerances between and around signal pads can vary based on board fabrication site.

EXAMPLE STENCIL DESIGN

DGG0048A

TSSOP - 1.2 mm max height

SMALL OUTLINE PACKAGE

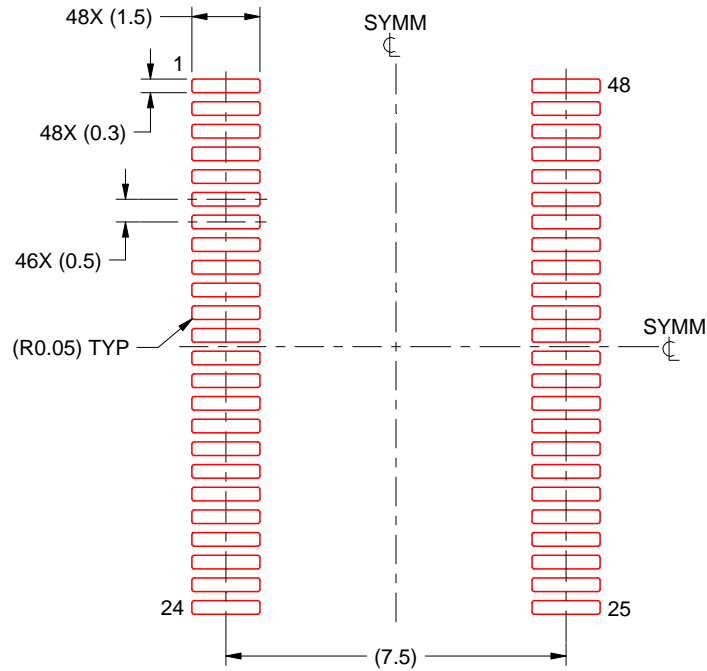

SOLDER PASTE EXAMPLE
BASED ON 0.125 mm THICK STENCIL
SCALE:6X

4214859/B 11/2020

NOTES: (continued)

7. Laser cutting apertures with trapezoidal walls and rounded corners may offer better paste release. IPC-7525 may have alternate design recommendations.
8. Board assembly site may have different recommendations for stencil design.

DGG (R-PDSO-G**)

PLASTIC SMALL-OUTLINE PACKAGE

48 PINS SHOWN

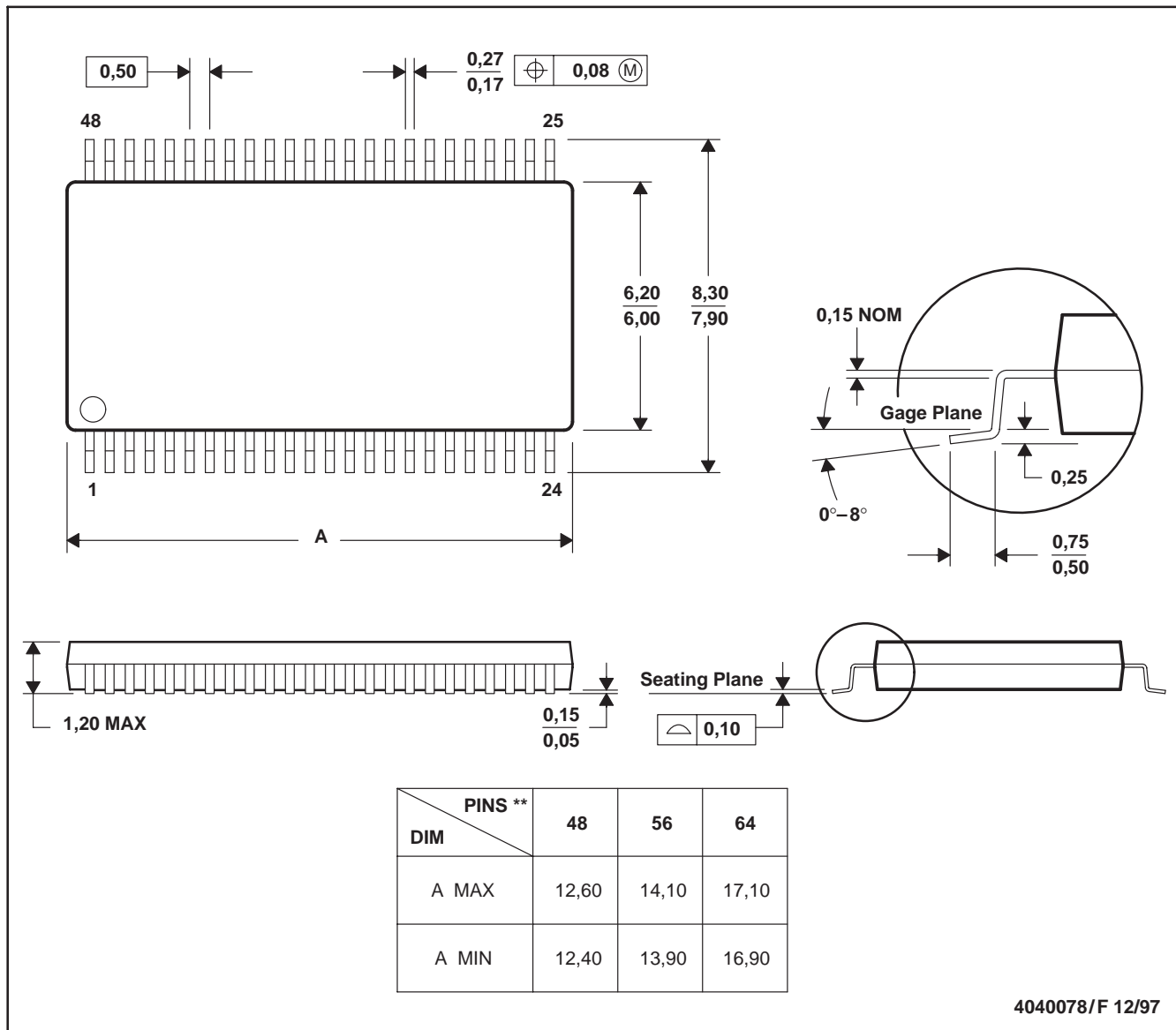

- NOTES: A. All linear dimensions are in millimeters.
 B. This drawing is subject to change without notice.
 C. Body dimensions do not include mold protrusion not to exceed 0,15.
 D. Falls within JEDEC MO-153

IMPORTANT NOTICE AND DISCLAIMER

TI PROVIDES TECHNICAL AND RELIABILITY DATA (INCLUDING DATASHEETS), DESIGN RESOURCES (INCLUDING REFERENCE DESIGNS), APPLICATION OR OTHER DESIGN ADVICE, WEB TOOLS, SAFETY INFORMATION, AND OTHER RESOURCES "AS IS" AND WITH ALL FAULTS, AND DISCLAIMS ALL WARRANTIES, EXPRESS AND IMPLIED, INCLUDING WITHOUT LIMITATION ANY IMPLIED WARRANTIES OF MERCHANTABILITY, FITNESS FOR A PARTICULAR PURPOSE OR NON-INFRINGEMENT OF THIRD PARTY INTELLECTUAL PROPERTY RIGHTS.

These resources are intended for skilled developers designing with TI products. You are solely responsible for (1) selecting the appropriate TI products for your application, (2) designing, validating and testing your application, and (3) ensuring your application meets applicable standards, and any other safety, security, regulatory or other requirements.

These resources are subject to change without notice. TI grants you permission to use these resources only for development of an application that uses the TI products described in the resource. Other reproduction and display of these resources is prohibited. No license is granted to any other TI intellectual property right or to any third party intellectual property right. TI disclaims responsibility for, and you fully indemnify TI and its representatives against any claims, damages, costs, losses, and liabilities arising out of your use of these resources.

TI's products are provided subject to [TI's Terms of Sale](#), [TI's General Quality Guidelines](#), or other applicable terms available either on ti.com or provided in conjunction with such TI products. TI's provision of these resources does not expand or otherwise alter TI's applicable warranties or warranty disclaimers for TI products. Unless TI explicitly designates a product as custom or customer-specified, TI products are standard, catalog, general purpose devices.

TI objects to and rejects any additional or different terms you may propose.

Copyright © 2026, Texas Instruments Incorporated

Last updated 10/2025