



Precision, Gain of 0.2 Level Translation DIFFERENCE AMPLIFIER

FEATURES

- GAIN OF 0.2 TO INTERFACE $\pm 10V$ SIGNALS TO SINGLE-SUPPLY ADCs
- GAIN ACCURACY: $\pm 0.024\%$ (max)
- WIDE BANDWIDTH: 1.5MHz
- HIGH SLEW RATE: $15V/\mu s$
- LOW OFFSET VOLTAGE: $\pm 100\mu V$
- LOW OFFSET DRIFT: $\pm 1.5\mu V/^\circ C$
- SINGLE-SUPPLY OPERATION DOWN TO 1.8V

APPLICATIONS

- INDUSTRIAL PROCESS CONTROLS
- INSTRUMENTATION
- DIFFERENTIAL TO SINGLE-ENDED CONVERSION
- AUDIO LINE RECEIVERS

DESCRIPTION

The INA159 is a high slew rate, $G = 1/5$ difference amplifier consisting of a precision op amp with a precision resistor network. The gain of $1/5$ makes the INA159 useful to couple $\pm 10V$ signals to single-supply analog-to-digital converters (ADCs), particularly those operating on a single +5V supply. The on-chip resistors are laser-trimmed for accurate gain and high common-mode rejection. Excellent temperature coefficient of resistance (TCR) tracking of the resistors maintains gain accuracy and common-mode rejection over temperature. The input common-mode voltage range extends beyond the positive and negative supply rails. It operates on a total of +1.8V to +5.5V single or split supplies. The INA159 reference input uses two resistors for easy mid-supply or reference biasing.

The difference amplifier is the foundation of many commonly-used circuits. The INA159 provides this circuit function without using an expensive external precision resistor network. The INA159 is available in an MSOP-8 surface-mount package and is specified for operation over the extended industrial temperature range, $-40^\circ C$ to $+125^\circ C$.

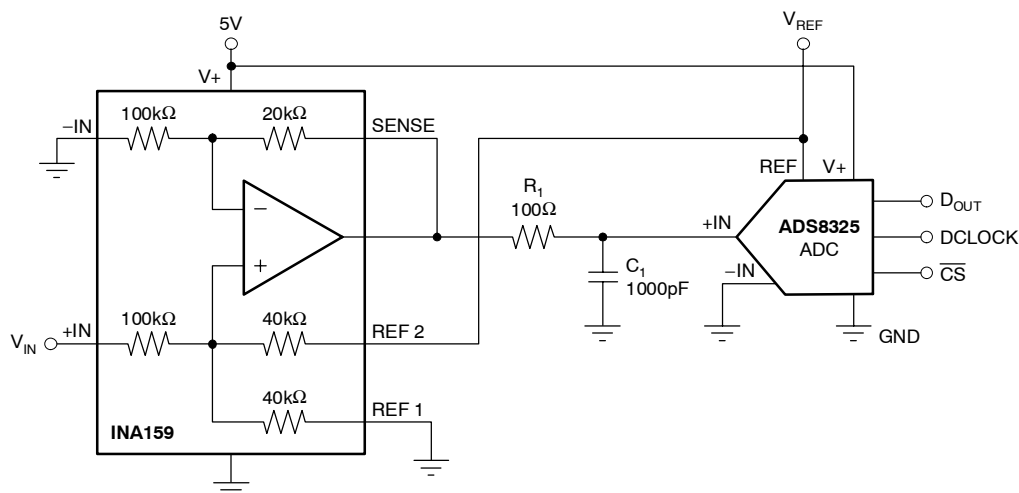

Figure 1. Typical Application



Please be aware that an important notice concerning availability, standard warranty, and use in critical applications of Texas Instruments semiconductor products and disclaimers thereto appears at the end of this data sheet.

All trademarks are the property of their respective owners.

ABSOLUTE MAXIMUM RATINGS⁽¹⁾

| | |
|---|----------------------------|
| Supply Voltage | +5.5V |
| Signal Input Terminals (-IN and +IN), Voltage | ±30V |
| Reference (REF 1 and REF2) and Sense Pins | |
| Current | ±10mA |
| Voltage | (V-) - 0.5V to (V+) + 0.5V |
| Output Short Circuit | Continuous |
| Operating Temperature | -40°C to +150°C |
| Storage Temperature | -65°C to +150°C |
| Junction Temperature | +150°C |
| ESD Rating | |
| Human Body Model | 4000V |
| Charged Device Model | 1000V |

⁽¹⁾ Stresses above these ratings may cause permanent damage. Exposure to absolute maximum conditions for extended periods may degrade device reliability. These are stress ratings only, and functional operation of the device at these or any other conditions beyond those specified is not supported.



This integrated circuit can be damaged by ESD. Texas Instruments recommends that all integrated circuits be handled with appropriate precautions. Failure to observe proper handling and installation procedures can cause damage.

ESD damage can range from subtle performance degradation to complete device failure. Precision integrated circuits may be more susceptible to damage because very small parametric changes could cause the device not to meet its published specifications.

ORDERING INFORMATION⁽¹⁾

| PRODUCT | PACKAGE-LEAD | PACKAGE DESIGNATOR | PACKAGE MARKING |
|---------|--------------|--------------------|-----------------|
| INA159 | MSOP-8 | DGK | CJB |

⁽¹⁾ For the most current package and ordering information, see the Package Option Addendum at the end of this document, or see the TI web site at www.ti.com.

PIN CONFIGURATIONS

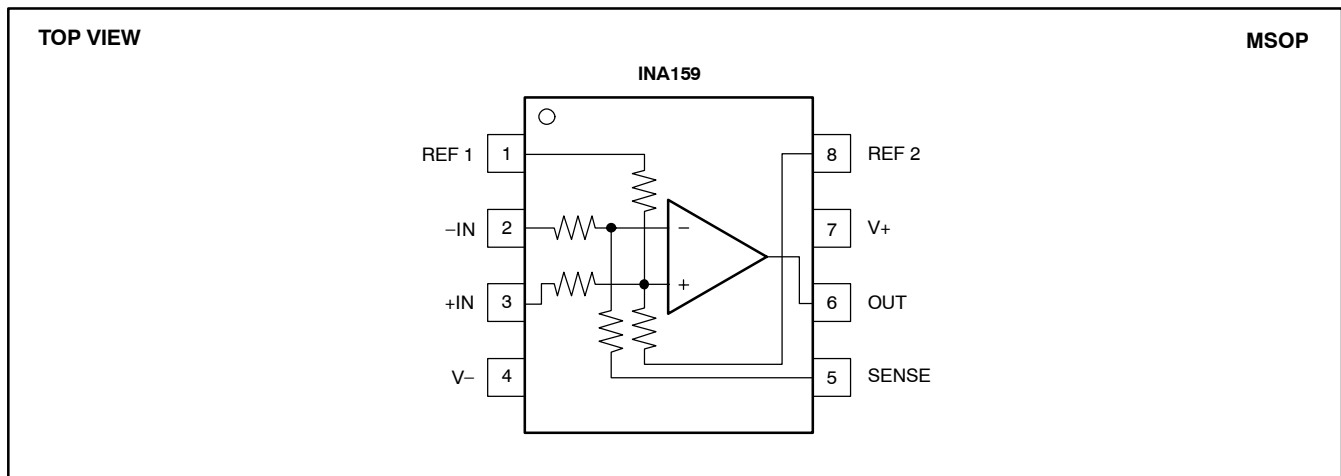

ELECTRICAL CHARACTERISTICS: $V_S = +5V$
Boldface limits apply over the specified temperature range, $T_A = -40^{\circ}\text{C}$ to $+125^{\circ}\text{C}$.

 At $T_A = +25^{\circ}\text{C}$, $R_L = 10\text{k}\Omega$ connected to $V_S/2$, REF pin 1 connected to ground, and REF pin 2 connected to $V_{REF} = 5V$, unless otherwise noted.

| PARAMETER | CONDITIONS | INA159 | | | UNIT |
|---|---|--|-------------------------------|-------------|--------------------------------|
| | | MIN | TYP | MAX | |
| OFFSET VOLTAGE⁽¹⁾ | RTO | | | | |
| Initial ⁽¹⁾ V_{OS} | $V_S = \pm 2.5V$, Reference and Input Pins Grounded | | ± 100 | ± 500 | μV |
| vs Temperature | | | ± 1.5 | | $\mu\text{V}/^{\circ}\text{C}$ |
| vs Power Supply | $V_S = \pm 0.9V$ to $\pm 2.75V$ | | ± 20 | ± 100 | $\mu\text{V}/V$ |
| Reference Divider Accuracy ⁽²⁾ | | | ± 0.002 | ± 0.024 | % |
| over Temperature | | | ± 0.002 | | % |
| INPUT IMPEDANCE⁽³⁾ | | | | | |
| Differential | | | 240 | | $\text{k}\Omega$ |
| Common-Mode | | | 60 | | $\text{k}\Omega$ |
| INPUT VOLTAGE RANGE | RTI | | | | |
| Common-Mode Voltage Range | V_{CM} | | 17.5 | | V |
| Positive | | | -12.5 | | V |
| Negative | | | | | |
| Common-Mode Rejection Ratio | $V_{CM} = -10V$ to $+10V$, $R_S = 0\Omega$ | 80 | 96 | | dB |
| over Temperature | | | 94 | | dB |
| OUTPUT VOLTAGE NOISE⁽⁴⁾ | RTO | | | | |
| $f = 0.1\text{Hz}$ to 10Hz | | | 10 | | μV_{PP} |
| $f = 10\text{kHz}$ | | | 30 | | $\text{nV}/\sqrt{\text{Hz}}$ |
| GAIN | $V_{REF2} = 4.096V$, R_L Connected to GND, $(V_{IN+}) - (V_{IN-}) = -10V$ to $+10V$, $V_{CM} = 0V$ | | | | |
| Initial Error | G | | 0.2 | ± 0.024 | V/V |
| vs Temperature | | | ± 0.005 | | % |
| Nonlinearity | | | ± 1 | | $\text{ppm}/^{\circ}\text{C}$ |
| | | | ± 0.0002 | | % of FS |
| OUTPUT | $V_{REF2} = 4.096V$, R_L Connected to GND $V_{REF2} = 4.096V$, R_L Connected to GND | | | | |
| Voltage, Positive | | $(V+) - 0.1$ | $(V+) - 0.02$ | | V |
| Voltage, Negative | | $(V-) + 0.048$ | $(V-) + 0.01$ | | V |
| Current Limit, Continuous to Common | | | ± 60 | | mA |
| Capacitive Load | | See Typical Characteristic | | | pF |
| Open-Loop Output Impedance | $f = 1\text{MHz}$, $I_O = 0$ | | 110 | | Ω |
| FREQUENCY RESPONSE | | | | | |
| Small-Signal Bandwidth | -3dB | | 1.5 | | MHz |
| Slew Rate | SR | | 15 | | V/ μs |
| Settling Time, 0.01% | t_s | 4V Output Step, $C_L = 100\text{pF}$ | 1 | | μs |
| Overload Recovery Time | | 50% Overdrive | 250 | | ns |
| POWER SUPPLY | | | | | |
| Specified Voltage Range | V_S | | +5 | | V |
| Operating Voltage Range | | +1.8 | | +5.5 | V |
| Quiescent Current | I_Q | $I_Q = 0\text{mA}$, $V_S = \pm 2.5V$, Reference and Input Pins Grounded | 1.1 | 1.5 | mA |
| TEMPERATURE RANGE | | | | | |
| Specified Range | | -40 | | +125 | $^{\circ}\text{C}$ |
| Operating Range | | -40 | | +150 | $^{\circ}\text{C}$ |
| Storage Range | | -65 | | +150 | $^{\circ}\text{C}$ |
| Thermal Resistance | θ_{JA} | Surface-Mount | 150 | | $^{\circ}\text{C}/\text{W}$ |
| MSOP-8 | | | | | |

(1) Includes effects of amplifier input bias and offset currents.

(2) Reference divider accuracy specifies the match between the reference divider resistors using the configuration in Figure 2.

 (3) Internal resistors are ratio matched but have $\pm 20\%$ absolute value.

(4) Includes effects of amplifier input current noise and thermal noise contribution of resistor network.

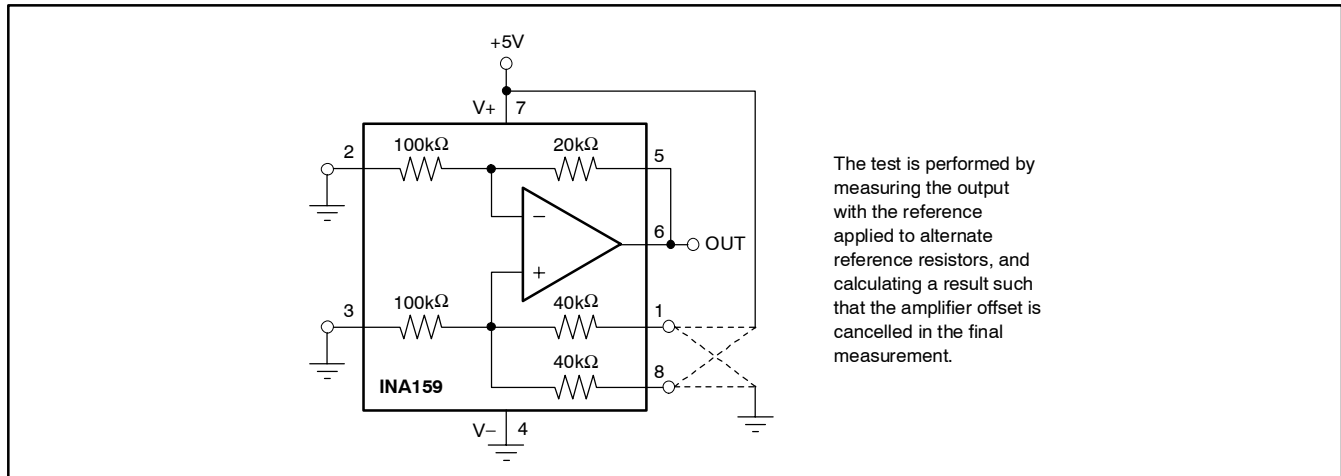
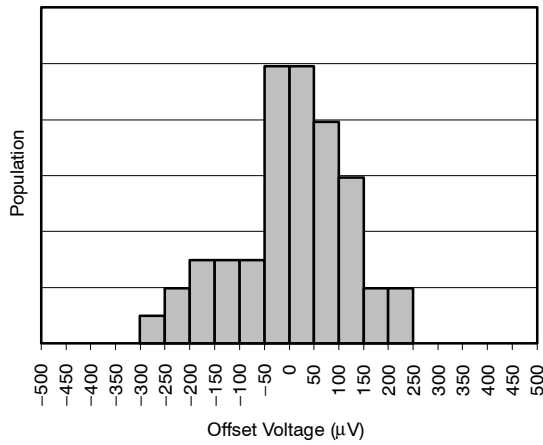

Figure 2. Test Circuit for Reference Divider Accuracy

TYPICAL CHARACTERISTICS

At $T_A = +25^\circ\text{C}$, $R_L = 10\text{k}\Omega$ connected to $V_S/2$, REF pin 1 connected to ground, and REF pin 2 connected to $V_{REF} = 5\text{V}$, unless otherwise noted.

OFFSET VOLTAGE PRODUCTION DISTRIBUTION



OFFSET VOLTAGE DRIFT PRODUCTION DISTRIBUTION

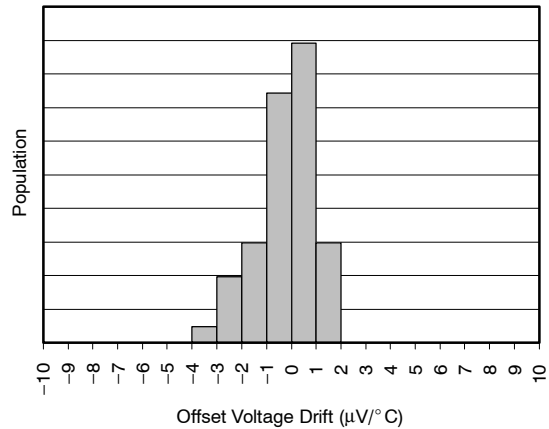

GAIN vs FREQUENCY

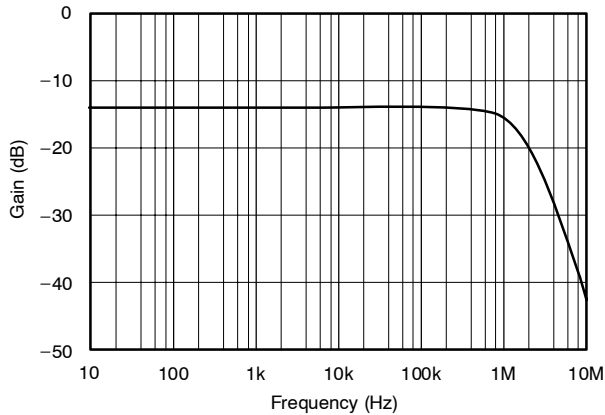

POWER-SUPPLY REJECTION RATIO vs FREQUENCY

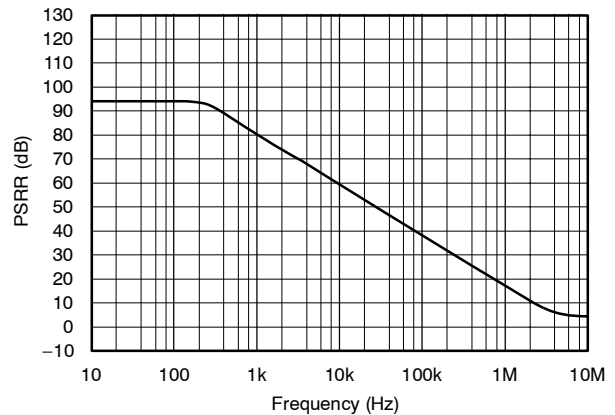

TYPICAL CHARACTERISTICS (continued)

At $T_A = +25^\circ\text{C}$, $R_L = 10\text{k}\Omega$ connected to $V_S/2$, REF pin 1 connected to ground, and REF pin 2 connected to $V_{REF} = 5\text{V}$, unless otherwise noted.

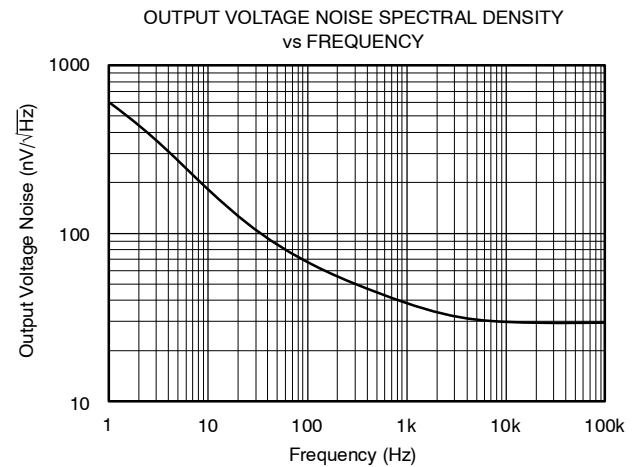
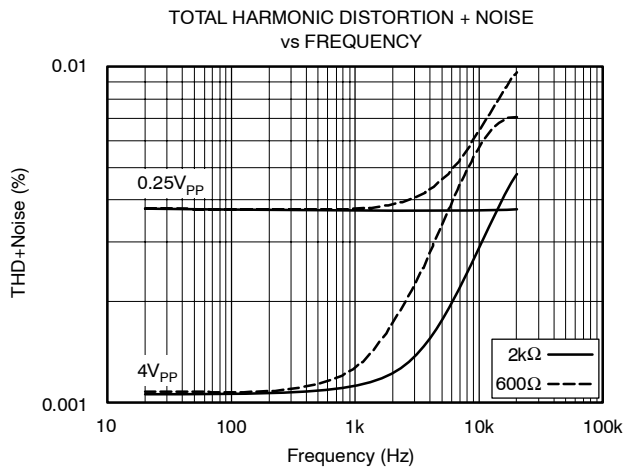
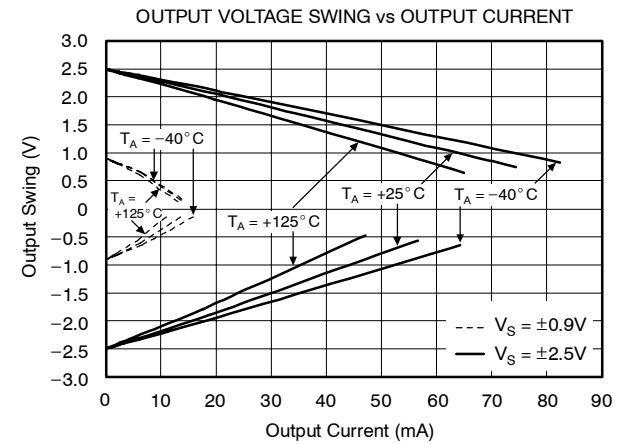
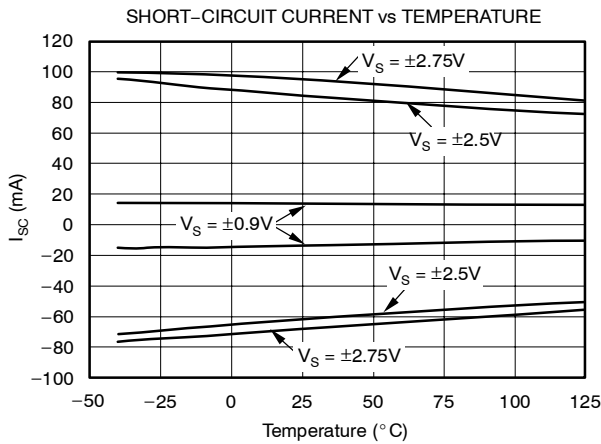
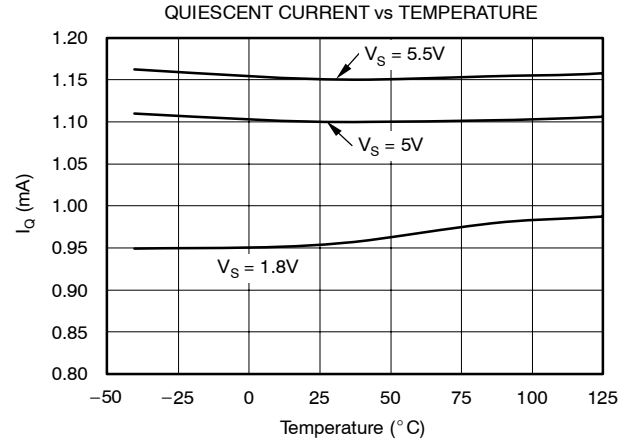
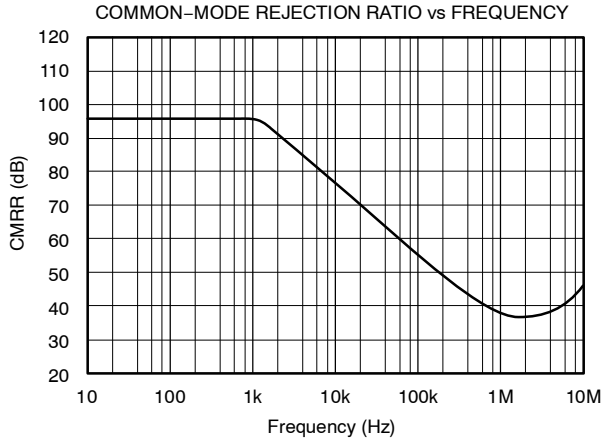

TYPICAL CHARACTERISTICS (continued)

At $T_A = +25^\circ\text{C}$, $R_L = 10\text{k}\Omega$ connected to $V_S/2$, REF pin 1 connected to ground, and REF pin 2 connected to $V_{REF} = 5\text{V}$, unless otherwise noted.

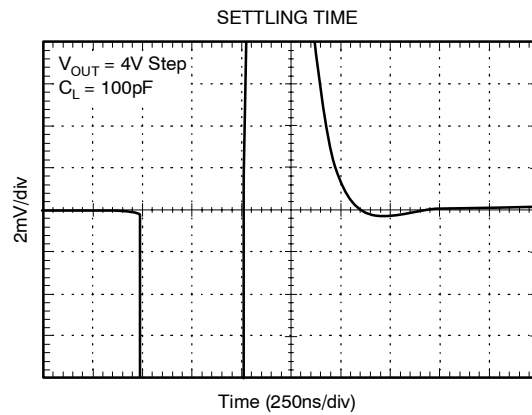
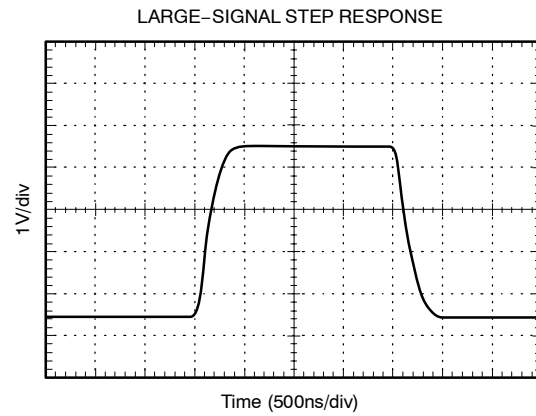
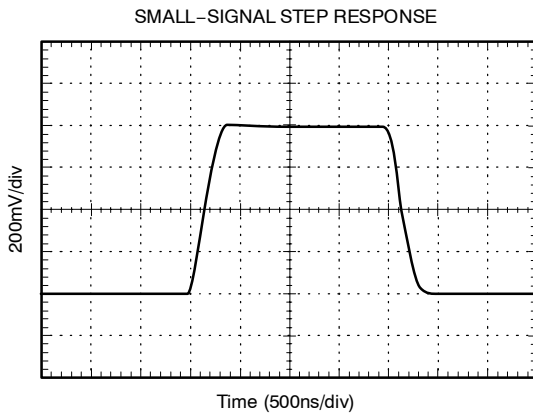
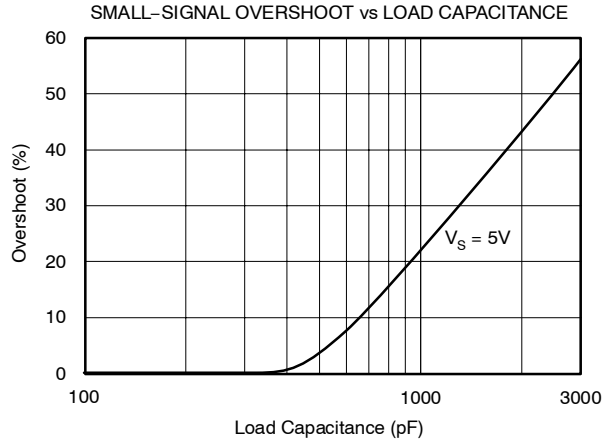
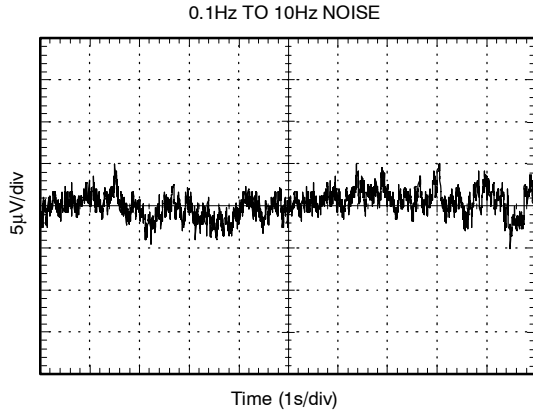

APPLICATION INFORMATION

The internal op amp of the INA159 has a rail-to-rail common-mode voltage capability at its inputs. A rail-to-rail op amp allows the use of $\pm 10V$ inputs into a circuit biased to 1/2 of a 5V reference (2.5V quiescent output). The inputs to the op amp will swing from approximately 400mV to 3.75V in this application.

The unique input topology of the INA159 eliminates the input offset transition region typical of most rail-to-rail complementary stage operational amplifiers. This allows the INA159 to provide superior glitch- and transition-free performance over the entire common-mode range.

Good layout practice includes the use of a 0.1 μ F bypass capacitor placed closely across the supply pins.

COMMON-MODE RANGE

The common-mode range of the INA159 is a function of supply voltage and reference. Where both pins, REF1 and REF2, are connected together:

$$V_{CM+} = (V+) + 5[(V+) - V_{REF}] \quad (1)$$

$$V_{CM-} = (V-) - 5[V_{REF} - (V-)] \quad (2)$$

Where one REF pin is connected to the reference, and the other pin grounded (1/2 reference connection):

$$V_{CM+} = (V+) + 5[(V+) - (0.5V_{REF})] \quad (3)$$

$$V_{CM-} = (V-) - 5[(0.5V_{REF}) - (V-)] \quad (4)$$

Some typical values are shown in Table 1.

Table 1. Common-Mode Range For Various Supply and Reference Voltages

| REF 1 and REF 2 Connected Together | | | | |
|------------------------------------|----|------------------|------------------|------------------|
| V+ | V- | V _{REF} | V _{CM+} | V _{CM-} |
| 5 | 0 | 3 | 15 | -15 |
| 5 | 0 | 2.5 | 17.5 | -12.5 |
| 5 | 0 | 1.25 | 23.75 | -6.25 |
| 1/2 Reference Connection | | | | |
| V+ | V- | V _{REF} | V _{CM+} | V _{CM-} |
| 5 | 0 | 5 | 17.5 | -12.5 |
| 5 | 0 | 4.096 | 19.76 | -10.24 |
| 5 | 0 | 2.5 | 23.75 | -6.25 |
| 3.3 | 0 | 3.3 | 11.55 | -8.25 |
| 3.3 | 0 | 2.5 | 13.55 | -6.25 |
| 3.3 | 0 | 1.25 | 16.675 | -3.125 |

Table 2. Input and Output Relationships for Various Reference and Connection Combinations

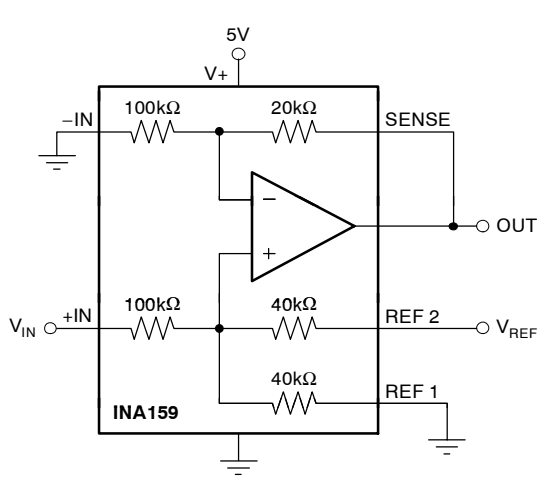
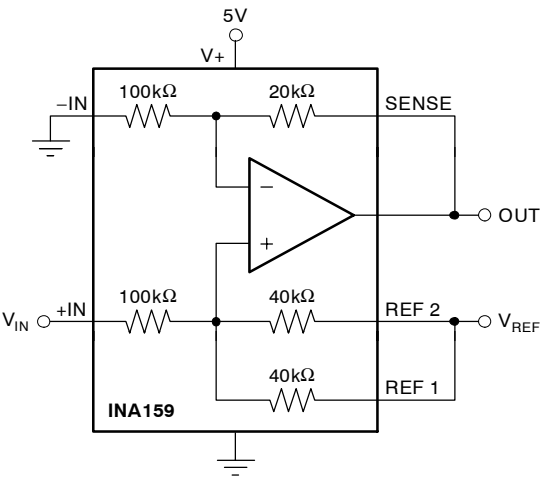
| V _{REF} (V) | REF CONNECTION | V _{OUT} for V _{IN} = 0 (V) | LINEAR V _{IN} RANGE (V) | USEFUL V _{OUT} SWING (V) |
|----------------------|--|--|------------------------------------|---------------------------------------|
| 5 |  | 2.5 | +10 0 -10 | 4.5 (±2V swing) 0.5 |
| 4.096 | | 2.048 | +10 0 -10 | 4.048 (±2V swing) 0.048 |
| 3.3 | | 1.65 | +10 0 -7.885 | 3.65 (-1.577V, +2V swing) 0.048 |
| 2.5 | | 1.25 | +10 (also +5) 0 -6 (also -5) | 3.25 (-1.2V, +2V swing) 0.048 |
| 1.8 | | 0.9 | +10 0 -4.26 | 2.9 (-0.852V, +2V swing) 0.048 |
| 2.5 |  | 2.5 | +10 0 -10 | 4.5 (±2V swing) 0.5 |
| 1.8 | | 1.8 | +10 0 -8.76 | 3.8 (-1.752V, +2V swing) 0.048 |
| 1.2 | | 1.2 | +10 0 -5.76 | 3.2 (-1.15V, +2V swing) 0.048 |

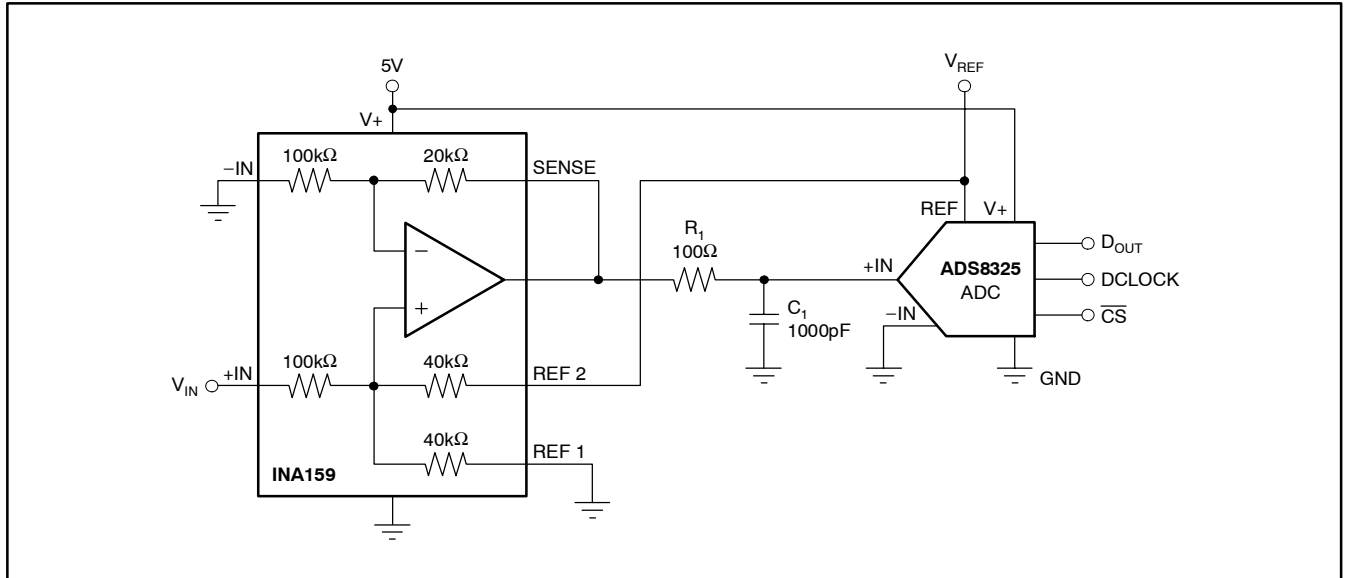

Figure 3. Typical Application Circuit Interfacing to Medium-Speed, Single-Supply ADCs

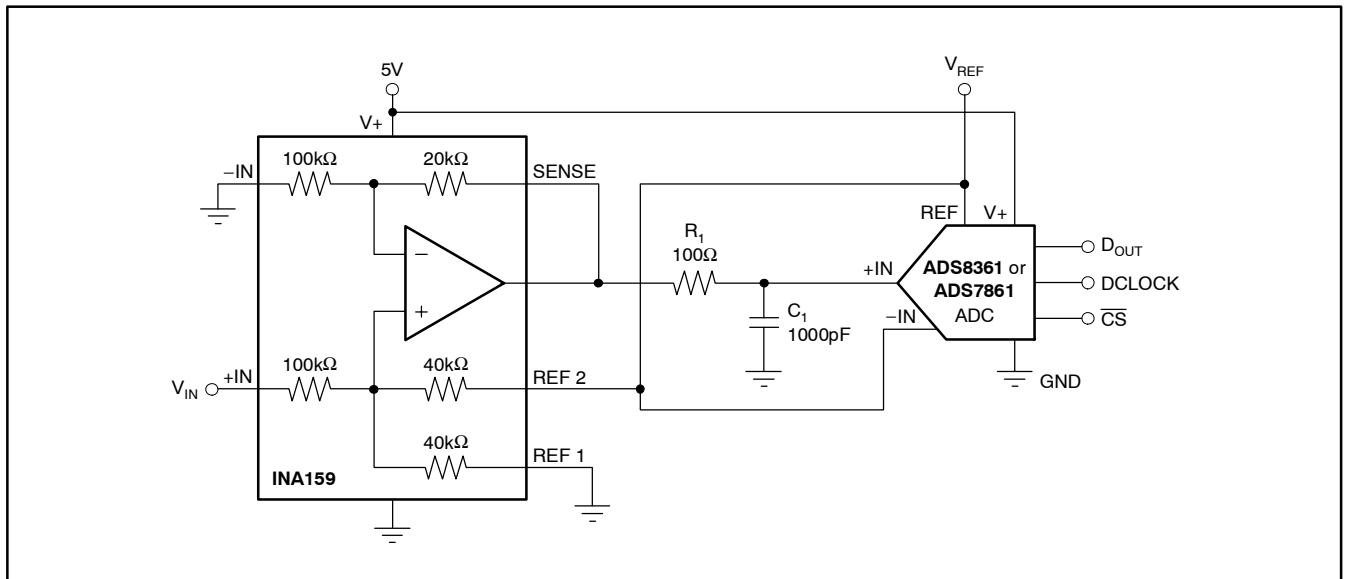
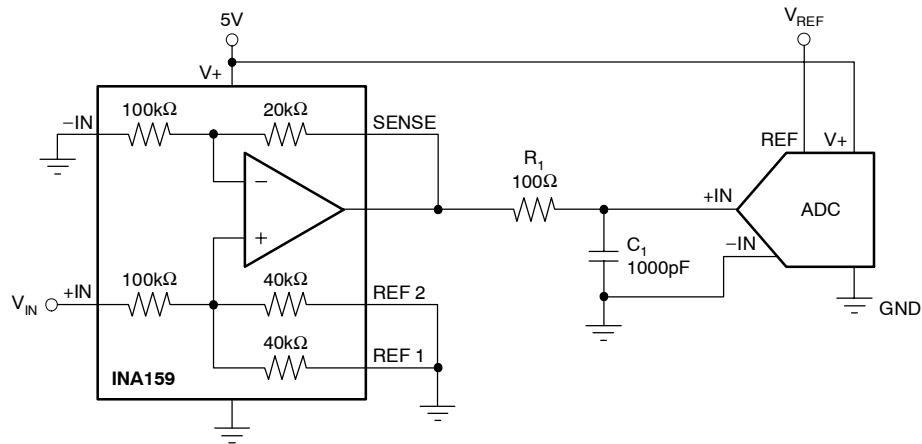
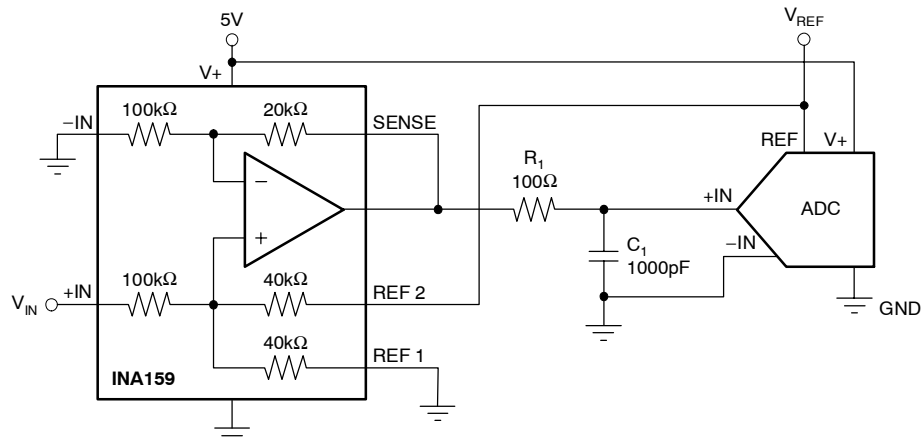

Figure 4. Typical Application Circuit Interfacing to Medium-Speed, Single-Supply ADCs with Pseudo-Differential Inputs (such as the ADS7861 and ADS8361)



a) Unipolar, Noninverting, $G = 0.2$



b) Bipolar, Noninverting, $G = 0.2$

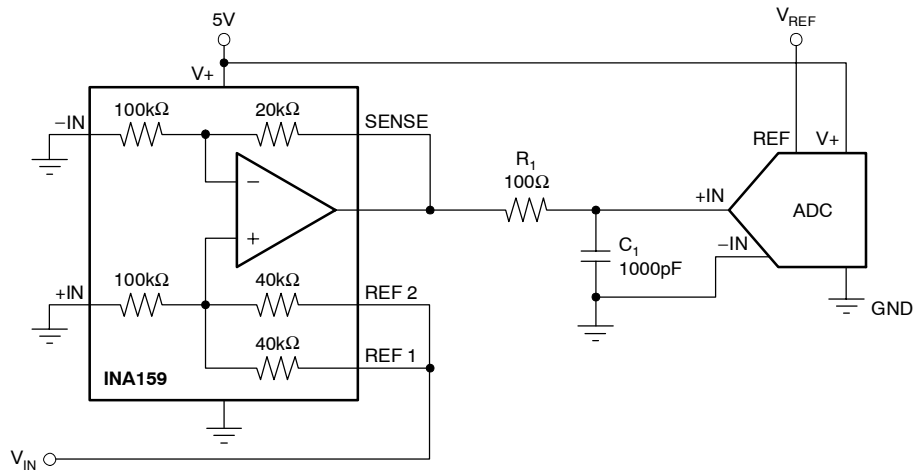

c) Unipolar, Unity Gain

Figure 5. Basic INA159 Configurations

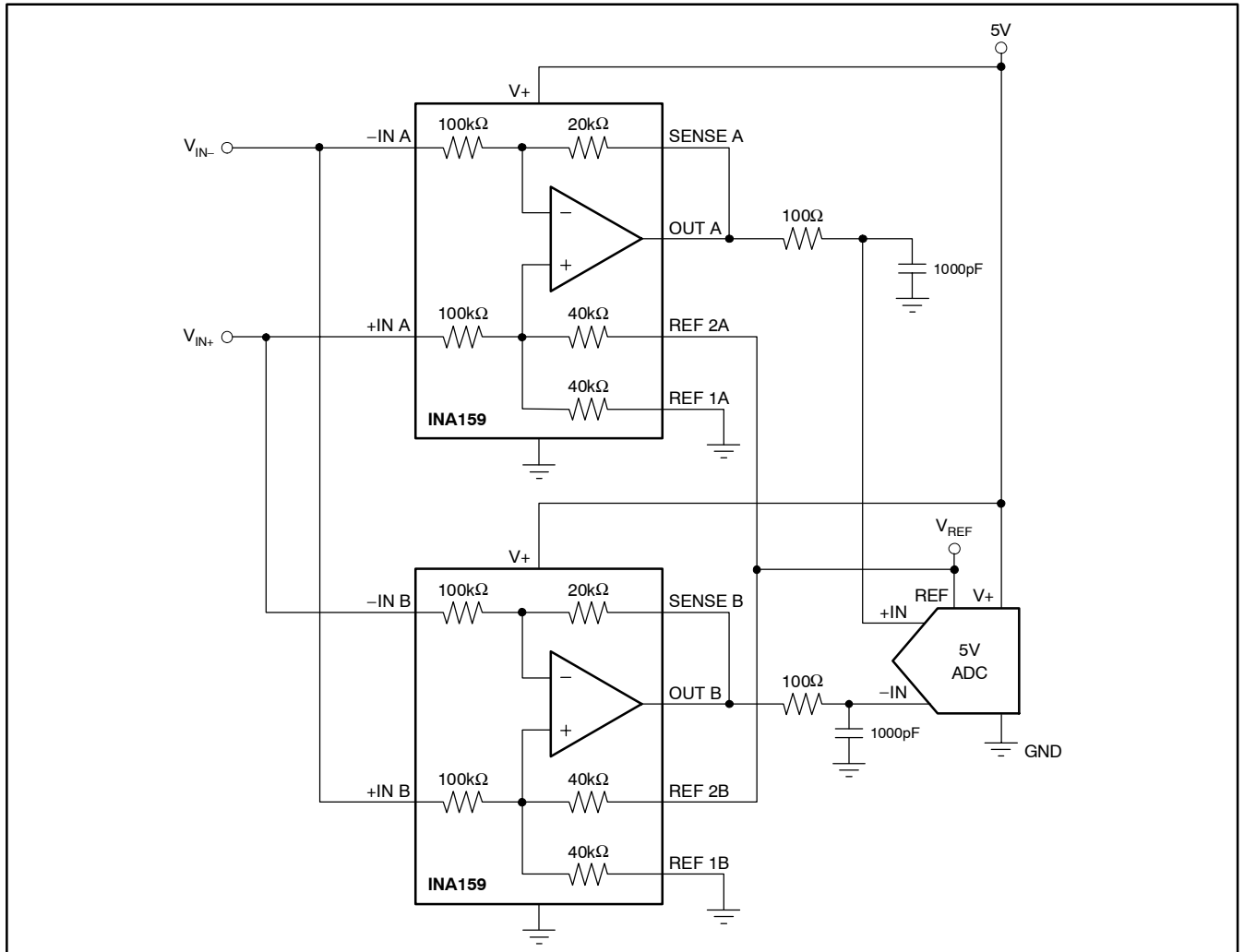

Figure 6. Differential ADC Drive

PACKAGING INFORMATION

| Orderable part number | Status (1) | Material type (2) | Package Pins | Package qty Carrier | RoHS (3) | Lead finish/ Ball material (4) | MSL rating/ Peak reflow (5) | Op temp (°C) | Part marking (6) |
|------------------------------|---------------|----------------------|-----------------|-----------------------|-------------|--------------------------------------|-----------------------------------|--------------|---------------------|
| INA159AIDGKR | Active | Production | VSSOP (DGK) 8 | 2500 LARGE T&R | Yes | Call TI Nipdauag Nipdau | Level-1-260C-UNLIM | -40 to 125 | CJB |
| INA159AIDGKR.A | Active | Production | VSSOP (DGK) 8 | 2500 LARGE T&R | Yes | NIPDAU | Level-1-260C-UNLIM | -40 to 125 | CJB |
| INA159AIDGKRG4 | Active | Production | VSSOP (DGK) 8 | 2500 LARGE T&R | Yes | NIPDAU | Level-1-260C-UNLIM | -40 to 125 | CJB |
| INA159AIDGKT | Active | Production | VSSOP (DGK) 8 | 250 SMALL T&R | Yes | Call TI Nipdauag Nipdau | Level-1-260C-UNLIM | -40 to 125 | CJB |
| INA159AIDGKT.A | Active | Production | VSSOP (DGK) 8 | 250 SMALL T&R | Yes | NIPDAU | Level-1-260C-UNLIM | -40 to 125 | CJB |
| INA159AIDGKTG4 | Active | Production | VSSOP (DGK) 8 | 250 SMALL T&R | Yes | NIPDAU | Level-1-260C-UNLIM | -40 to 125 | CJB |

(1) **Status:** For more details on status, see our [product life cycle](#).

(2) **Material type:** When designated, preproduction parts are prototypes/experimental devices, and are not yet approved or released for full production. Testing and final process, including without limitation quality assurance, reliability performance testing, and/or process qualification, may not yet be complete, and this item is subject to further changes or possible discontinuation. If available for ordering, purchases will be subject to an additional waiver at checkout, and are intended for early internal evaluation purposes only. These items are sold without warranties of any kind.

(3) **RoHS values:** Yes, No, RoHS Exempt. See the [TI RoHS Statement](#) for additional information and value definition.

(4) **Lead finish/Ball material:** Parts may have multiple material finish options. Finish options are separated by a vertical ruled line. Lead finish/Ball material values may wrap to two lines if the finish value exceeds the maximum column width.

(5) **MSL rating/Peak reflow:** The moisture sensitivity level ratings and peak solder (reflow) temperatures. In the event that a part has multiple moisture sensitivity ratings, only the lowest level per JEDEC standards is shown. Refer to the shipping label for the actual reflow temperature that will be used to mount the part to the printed circuit board.

(6) **Part marking:** There may be an additional marking, which relates to the logo, the lot trace code information, or the environmental category of the part.

Multiple part markings will be inside parentheses. Only one part marking contained in parentheses and separated by a "~" will appear on a part. If a line is indented then it is a continuation of the previous line and the two combined represent the entire part marking for that device.

Important Information and Disclaimer: The information provided on this page represents TI's knowledge and belief as of the date that it is provided. TI bases its knowledge and belief on information provided by third parties, and makes no representation or warranty as to the accuracy of such information. Efforts are underway to better integrate information from third parties. TI has taken and continues to take reasonable steps to provide representative and accurate information but may not have conducted destructive testing or chemical analysis on incoming materials and chemicals. TI and TI suppliers consider certain information to be proprietary, and thus CAS numbers and other limited information may not be available for release.

In no event shall TI's liability arising out of such information exceed the total purchase price of the TI part(s) at issue in this document sold by TI to Customer on an annual basis.

OTHER QUALIFIED VERSIONS OF INA159 :

- Enhanced Product : [INA159-EP](#)

NOTE: Qualified Version Definitions:

- Enhanced Product - Supports Defense, Aerospace and Medical Applications

TAPE AND REEL INFORMATION

QUADRANT ASSIGNMENTS FOR PIN 1 ORIENTATION IN TAPE

*All dimensions are nominal

| Device | Package Type | Package Drawing | Pins | SPQ | Reel Diameter (mm) | Reel Width W1 (mm) | A0 (mm) | B0 (mm) | K0 (mm) | P1 (mm) | W (mm) | Pin1 Quadrant |
|--------------|--------------|-----------------|------|------|--------------------|--------------------|---------|---------|---------|---------|--------|---------------|
| INA159AIDGKR | VSSOP | DGK | 8 | 2500 | 330.0 | 12.4 | 5.3 | 3.4 | 1.4 | 8.0 | 12.0 | Q1 |
| INA159AIDGKT | VSSOP | DGK | 8 | 250 | 180.0 | 12.4 | 5.3 | 3.4 | 1.4 | 8.0 | 12.0 | Q1 |

TAPE AND REEL BOX DIMENSIONS

*All dimensions are nominal

| Device | Package Type | Package Drawing | Pins | SPQ | Length (mm) | Width (mm) | Height (mm) |
|--------------|--------------|-----------------|------|------|-------------|------------|-------------|
| INA159AIDGKR | VSSOP | DGK | 8 | 2500 | 353.0 | 353.0 | 32.0 |
| INA159AIDGKT | VSSOP | DGK | 8 | 250 | 213.0 | 191.0 | 35.0 |

EXAMPLE BOARD LAYOUT

DGK0008A

™ VSSOP - 1.1 mm max height

SMALL OUTLINE PACKAGE

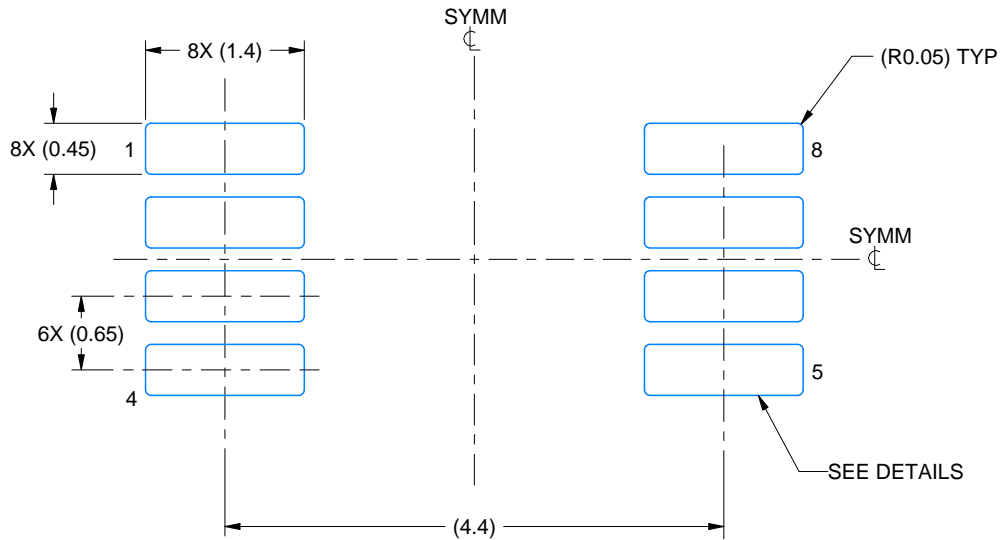

LAND PATTERN EXAMPLE
EXPOSED METAL SHOWN
SCALE: 15X

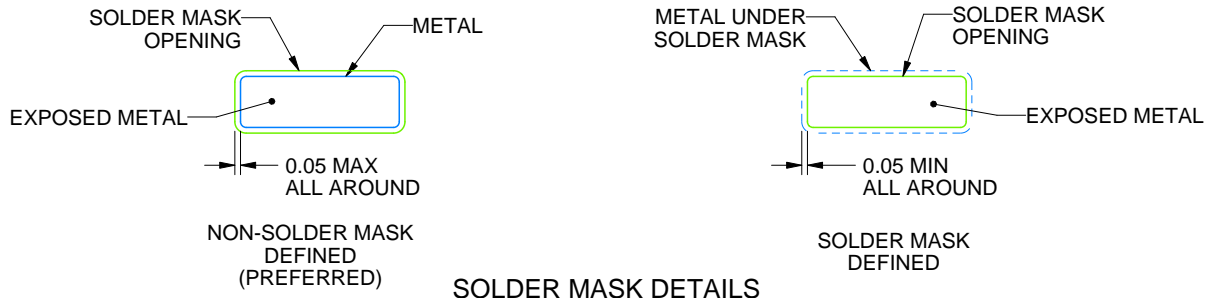

SOLDER MASK DETAILS

4214862/A 04/2023

NOTES: (continued)

6. Publication IPC-7351 may have alternate designs.
7. Solder mask tolerances between and around signal pads can vary based on board fabrication site.
8. Vias are optional depending on application, refer to device data sheet. If any vias are implemented, refer to their locations shown on this view. It is recommended that vias under paste be filled, plugged or tented.
9. Size of metal pad may vary due to creepage requirement.

EXAMPLE STENCIL DESIGN

DGK0008A

™ VSSOP - 1.1 mm max height

SMALL OUTLINE PACKAGE

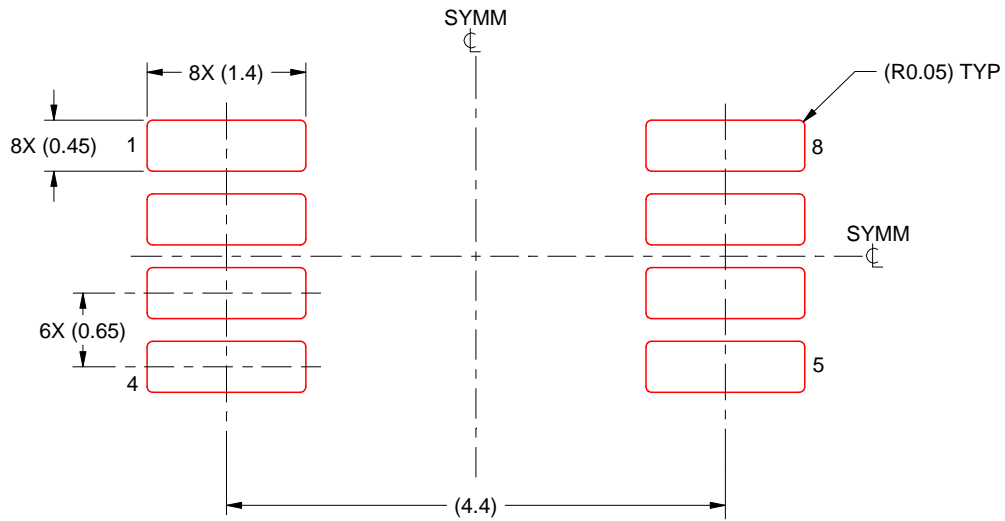

SOLDER PASTE EXAMPLE
SCALE: 15X

4214862/A 04/2023

NOTES: (continued)

11. Laser cutting apertures with trapezoidal walls and rounded corners may offer better paste release. IPC-7525 may have alternate design recommendations.
12. Board assembly site may have different recommendations for stencil design.

IMPORTANT NOTICE AND DISCLAIMER

TI PROVIDES TECHNICAL AND RELIABILITY DATA (INCLUDING DATASHEETS), DESIGN RESOURCES (INCLUDING REFERENCE DESIGNS), APPLICATION OR OTHER DESIGN ADVICE, WEB TOOLS, SAFETY INFORMATION, AND OTHER RESOURCES "AS IS" AND WITH ALL FAULTS, AND DISCLAIMS ALL WARRANTIES, EXPRESS AND IMPLIED, INCLUDING WITHOUT LIMITATION ANY IMPLIED WARRANTIES OF MERCHANTABILITY, FITNESS FOR A PARTICULAR PURPOSE OR NON-INFRINGEMENT OF THIRD PARTY INTELLECTUAL PROPERTY RIGHTS.

These resources are intended for skilled developers designing with TI products. You are solely responsible for (1) selecting the appropriate TI products for your application, (2) designing, validating and testing your application, and (3) ensuring your application meets applicable standards, and any other safety, security, regulatory or other requirements.

These resources are subject to change without notice. TI grants you permission to use these resources only for development of an application that uses the TI products described in the resource. Other reproduction and display of these resources is prohibited. No license is granted to any other TI intellectual property right or to any third party intellectual property right. TI disclaims responsibility for, and you fully indemnify TI and its representatives against any claims, damages, costs, losses, and liabilities arising out of your use of these resources.

TI's products are provided subject to [TI's Terms of Sale](#), [TI's General Quality Guidelines](#), or other applicable terms available either on ti.com or provided in conjunction with such TI products. TI's provision of these resources does not expand or otherwise alter TI's applicable warranties or warranty disclaimers for TI products. Unless TI explicitly designates a product as custom or customer-specified, TI products are standard, catalog, general purpose devices.

TI objects to and rejects any additional or different terms you may propose.

Copyright © 2026, Texas Instruments Incorporated

Last updated 10/2025