

IWRL6432WMOD Certified 60GHz mmWave Radar Module For Motion and Presence Detection

1 Features

- **Ease of Use**
 - Integrated IWRL6432W mmWave sensor
 - Small module size: 31mm x 15mm
 - Quad Flat Module (QFM) - 4 x 9 LGA Grid
 - Easy to mount 30-pad Land Grid Array (LGA)
 - Easy to integrate - 18 signals interface
 - Simple Configurable APIs (via SPI) to configure Range, Motion Sensitivity, Update rate via external MCU
 - Motion and Presence detection indication via GPIO
 - Integrated 3 receive and 2 transmit channel antennas etched on PCB; Power Distribution Network and 40MHz XTAL
- **FMCW Transceiver**
 - On-chip integrated PLL, transmitter, receiver, baseband and ADC
 - Frequency Modulated Continuous Wave operation
 - 5MHz IF bandwidth, real-only Rx channels
- **Antenna**
 - Field of View (FoV): $\pm 60^\circ$ (Azimuth); $\pm 60^\circ$ (Elevation)
 - 57GHz - 61.5GHz antenna coverage with 4.5GHz continuous bandwidth
- **Certifications**
 - Modular certification with FCC, RED, MIC certifications
- **Performance**
 - Human Presence Detection Range typically:
 - At 0° : 15m
 - At edge of FoV: 8m
 - Built-in low power modes for power saving

- **Power management**
 - 3.3V VCC and VIO operation
 - Built-in 1.8V regulator on module
 - Built-in on-chip LDO network for enhanced PSRR
 - BOM-Optimized mode
- **Host Interface**
 - SPI
 - Host PC interface using TI mmWave uDFP
 - Interfaces with external MCU
- **Other interfaces**
 - Presence Indication
 - Wake Up Request
- **Temperature operating range**
 - Industrial grade temperature range: -40°C to 85°C

2 Applications

- [Air conditioner](#)
- [Automated door/gate](#)
- [Gaming](#)
- [Home theater & entertainment](#)
- [IP network camera](#)
- [Occupancy detector](#)
- [PC/Notebooks](#)
- [Portable electronics](#)
- [Refrigerators and freezers](#)
- [Smart watches](#)
- [Tablets](#)
- [Televisions](#)
- [Thermostat](#)
- [Video doorbell](#)
- [Robotics](#)

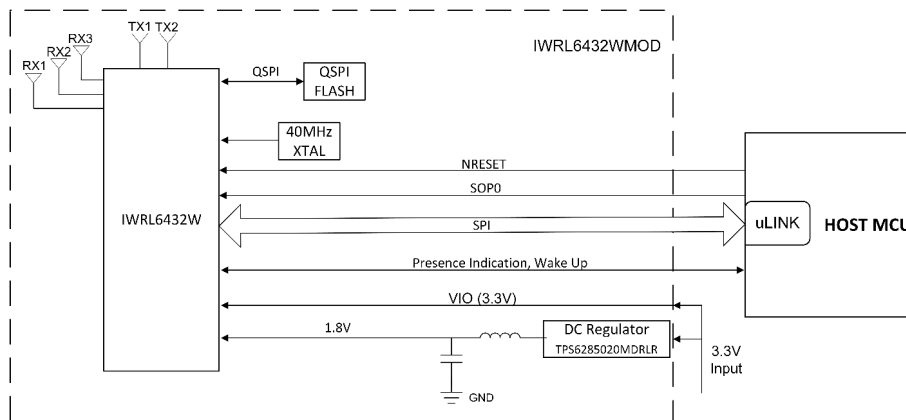

Figure 2-1. Example Application



3 Description

Texas Instruments' radar module IWRL6432WMOD is a compact 31mm × 15.5mm module that integrates a 60GHz patch antenna, on-board power management, flash memory, passives and crystal, eliminating the need for specialized mmWave system design expertise while providing simple software configuration options for range, sensitivity, and regions of interest. The module is distinguished by its comprehensive certification with FCC, RED, MIC that eliminates cost and effort for certification at the end product. Additionally the module provides either SPI based point cloud data outputs or GPIO based presence indication which aids flexible implementation. By addressing customer readiness challenges and enabling autonomous operation across applications such as motion sensing, occupancy detection, and smart home devices, this TI-designed, supported, and distributed device significantly reduces development complexity and accelerates time-to-market for customers seeking to embed mmWave radar sensor capabilities in their products.

Table 3-1. Packaging Information

ORDERABLE PART NUMBER ⁽¹⁾	PACKAGE	BODY SIZE ⁽²⁾	PACKAGING INFORMATION	DESCRIPTION
XI6432BAFCLIMBBR	MBB (QFM, 30)	31mm x 15.5mm	Tape & Reel	Pre-Production; Deep sleep enabled; Authenticated boot capable
IWRL6432BAFCLIMBBR	MBB (QFM, 30)	31mm x 15.5mm	Tape & Reel	Production; Deep sleep enabled; Authenticated boot capable

1. For more information, see [Device Nomenclature](#)
2. For more information, see [Mechanical, Packaging, and Orderable Information](#)

Functional Block Diagram

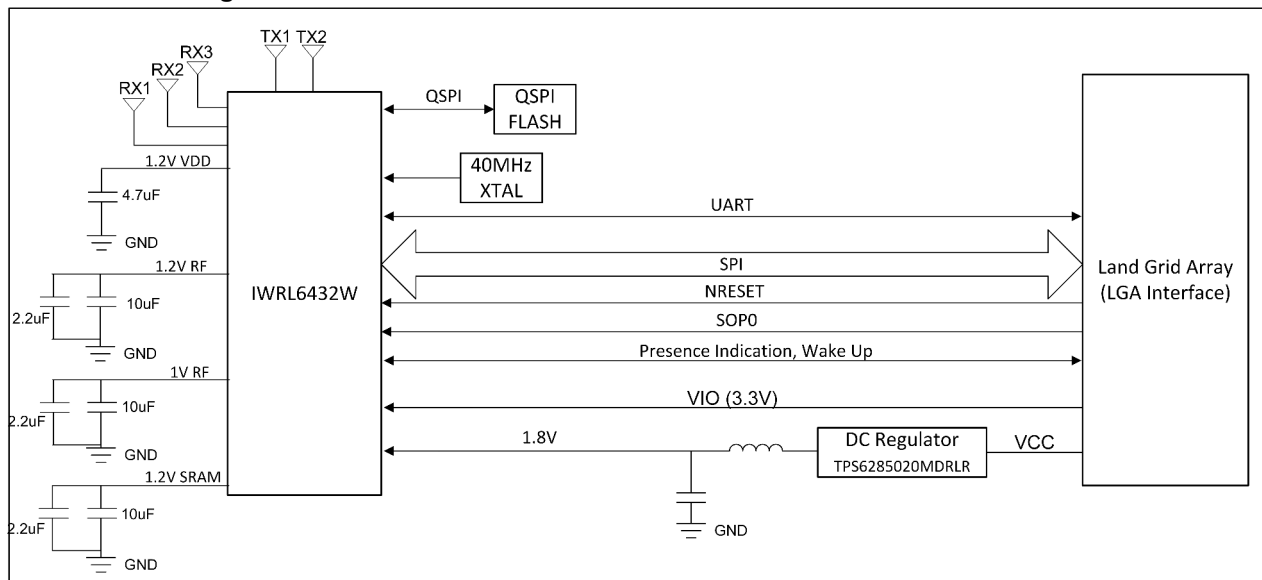

IWRL6432WMOD

Figure 3-1. Functional Block Diagram

Table of Contents

1 Features	1	6.2 Functional Block Diagram.....	17
2 Applications	1	6.3 Subsystems.....	18
3 Description	2	7 Device Certification	20
4 Terminal Configurations and Functions	4	7.1 FCC Certification and Statement.....	20
4.1 Pin Diagrams.....	4	7.2 ETSI/CE.....	20
4.2 Signal Descriptions.....	4	8 Applications, Implementation, and Layout	21
5 Specifications	5	8.1 Application Information.....	21
5.1 Absolute Maximum Ratings.....	5	8.2 Test Results.....	22
5.2 ESD Ratings.....	5	9 Device and Documentation Support	23
5.3 Recommended Operating Conditions.....	5	9.1 Device Nomenclature.....	23
5.4 Module Power Management.....	6	9.2 Device Marking.....	25
5.5 Typical Power Consumption Numbers.....	6	9.3 Documentation Support.....	25
5.6 Peak Current Requirement per Voltage Rail.....	6	9.4 Support Resources.....	25
5.7 RF Specification.....	7	9.5 Trademarks.....	26
5.8 Antenna Position.....	7	9.6 Electrostatic Discharge Caution.....	26
5.9 Antenna Gain Plot.....	9	9.7 Glossary.....	26
5.10 Thermal Resistance Characteristics.....	10	10 Reflow Information	27
5.11 Timing and Switching Characteristics.....	11	11 Revision History	27
6 Detailed Description	16	12 Mechanical, Packaging, and Orderable Information	29
6.1 Overview.....	16		

4 Terminal Configurations and Functions

4.1 Pin Diagrams

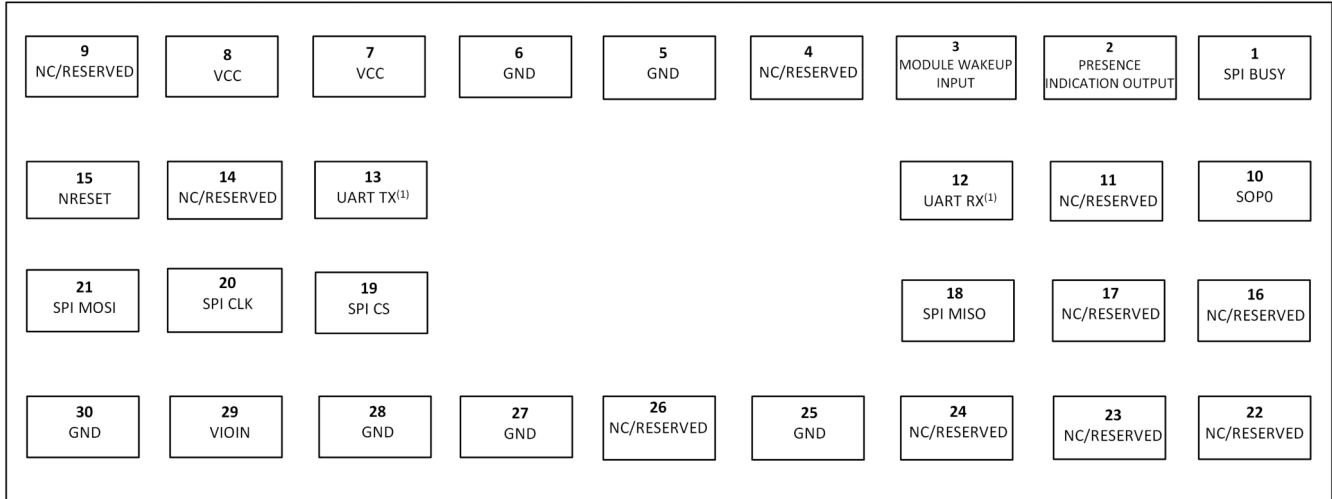

Figure 4-1. IWRL6432WMOD Pin Diagram (Top View)

1. UART TX and UART RX - For uDFP patch updates only. This is not the application interface.

4.2 Signal Descriptions

Note

All digital IO pins of the device (except NRESET) are non-failsafe; hence, care needs to be taken that they are not driven externally without the VIO supply being present to the device.

Table 4-1. Power Supply Signal Descriptions

SIGNAL NAME	DESCRIPTION	PIN TYPE	PIN
VCC	3.3V Supply	PWR	7, 8
VIOIN	3.3V supply	PWR	29
GND	GND	GND	5, 6, 25, 27, 28, 30
SPI BUSY	Host interrupt / SPI host clock request signal	O	1
SPI MOSI	SPI MOSI	I	21
SPI MISO	SPI MISO	O	18
SPI CLK	SPI Clock	I	20
SPI CS	SPI Chip Select	I	19
UART TX ⁽¹⁾	UART Transmit Data	O	13
UART RX ⁽¹⁾	UART Receive Data	I	12
SOPO	Sense On Power	A	10
NRESET	NRESET input	A	15
Presence Indication Output	Output for presence indication in the Region Of Interest	O	2
Module Wake Up Input	Input signal to wakeup the IWRL6432W	I	3
NC	No Connection	-	4, 9, 11, 14, 16, 17, 22, 23, 24, 26

1. For uDFP patch updates only. This is not the application interface.

5 Specifications

5.1 Absolute Maximum Ratings

PARAMETERS ^{(1) (2)}		MIN	MAX	UNIT
VCC	Input Supply Voltage (3.3V)	-0.5	3.8	V
VIOIN	I/O supply (3.3V): All CMOS I/Os operate on the same VIOIN voltage level	-0.5	3.8	V
T _J	Operating temperature range	-40	85	°C

- (1) Stresses beyond those listed under *Absolute Maximum Ratings* may cause permanent damage to the device. These are stress ratings only, and functional operation of the device at these or any other conditions beyond those indicated under *Recommended Operating Conditions* is not implied. Exposure to absolute-maximum-rated conditions for extended periods may affect device reliability.
- (2) All voltage values are with respect to GND, unless otherwise noted.

5.2 ESD Ratings

		DEVICE			VALUE	UNIT
V _(ESD)	Electrostatic discharge	IWRL6432WMOD	Human-body model (HBM)	All Pins to GND only ⁽¹⁾	±2000 ⁽¹⁾	V
		IWRL6432BDQAYFFR	Human-body model (HBM), per ANSI/ESDA/JEDEC JS-001 ⁽²⁾	All Pins	±1000	
		TPS628502MDRLR	Human body model (HBM), per ANSI/ESDA/JEDEC JS-001 ⁽²⁾	All Pins	±2000	

- (1) HBM stress for the IWRL6432WMOD module was limited to pin to GND stress combinations (+/-). This is not fully compliant to ESDA/JEDEC JS-001.
- (2) JEDEC document JEP155 states that 500V HBM allows safe manufacturing with a standard ESD control process.

5.3 Recommended Operating Conditions

		MIN	NOM	MAX	UNIT
VCC	Input Supply Voltage	3.135	3.3	3.465	V
VIOIN	I/O supply (3.3V): All CMOS I/Os can operate on this supply.	3.135	3.3	3.465	V
V _{IH}	Voltage Input High (3.3Vmode)	2.25			V
V _{IL}	Voltage Input Low (3.3Vmode)			0.62	V
V _{OH}	High-level output threshold (I _{OH} = 6mA)	VIOIN – 450			mV
V _{OL}	Low-level output threshold (I _{OL} = 6mA)			450	mV
NRESET, SOP0	V _{IL} (3.3V Mode)			0.3	V
	V _{IH} (3.3V Mode)	1.57			

5.4 Module Power Management

The module can be powered using a 3.3V input supply.

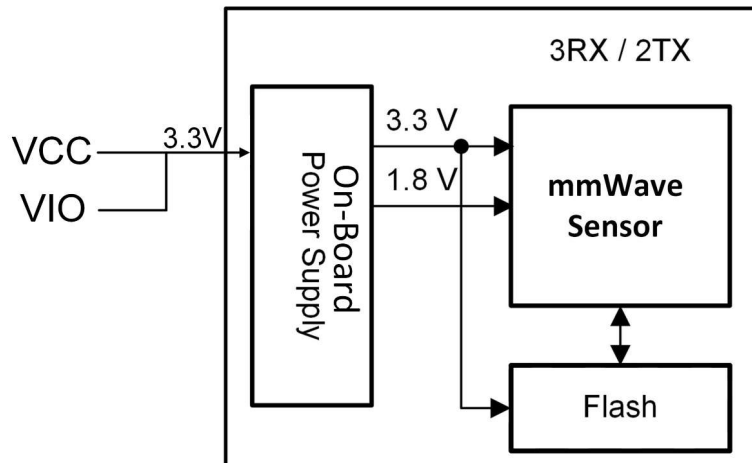

Figure 5-1. Module Power Management (3.3V I/O Topology)

5.5 Typical Power Consumption Numbers

Table 5-1 lists the typical power consumption for each power save modes in different power topologies and antenna configurations for a nominal device at 25C ambient temperature and nominal voltage conditions.

Table 5-1. Use-Case Power Consumed

Configuration	Radar Location	Typical Power Consumption (mW)
Max Range = 4m, Update Rate = 1Hz	Indoor	8.70
Max Range = 4m, Update Rate = 1Hz	Outdoor	8.93
Max Range = 11m, Update Rate = 4Hz	Indoor	36.10
Max Range = 11m, Update Rate = 4Hz	Outdoor	38.25
Max Range = 15m, Update Rate = 5Hz	Indoor	54.46
Max Range = 15m, Update Rate = 5Hz	Outdoor	59.31

5.6 Peak Current Requirement per Voltage Rail

Table 5-2 provides the max split rail current numbers.

Table 5-2. Maximum Peak Current per Voltage Rail

Supply Voltage Rail (V)	Maximum Current (mA) ⁽¹⁾
VCC (3.3V)	1000
VIO (3.3V)	90

1. The exact VIOIN current depends on the peripherals used and the frequency of operation.

5.7 RF Specification

The following specifications are for recommended operating conditions (unless otherwise noted)

PARAMETER		MIN	TYP	MAX	UNIT	
Antenna	Single transmitter output power (EIRP)	FCC		19	dBm	
		MIC		10	dBm	
	Effective isotropic noise figure (EINF)		9.6		dB	
	Frequency range	57		61.5	GHz	
	Bandwidth		4.5		GHz	
	Antenna gain		4.4		dBi	
	Field of View	Azimuth		120		Degrees
		Elevation		120		Degrees
	Azimuthal Angular Resolution ⁽¹⁾			19		Degrees
	Maximum Adult Human Presence Detection Range	Boresight		15		m
+/- 60°			8			

- For resolving objects near boresight with similar RCS.

5.8 Antenna Position

The module uses a single-element patch antenna for its three receiver and two transmitter antenna. The antenna array has been defined in a way that the angular resolution is maximized in azimuthal plane.

5.8.1 2D Antenna Array With 3D Detection Capability

The TX2 antenna placed $\lambda/2$ below the TX1 antenna in the elevation plane, as shown in Figure 5-2. This antenna geometry has a two rows, six element virtual antenna array with six elements in the azimuthal plane and two elements in the elevation plane as shown in Figure 5-3. This antenna is capable of detecting the range, angle and velocity in both azimuthal and elevation plane.

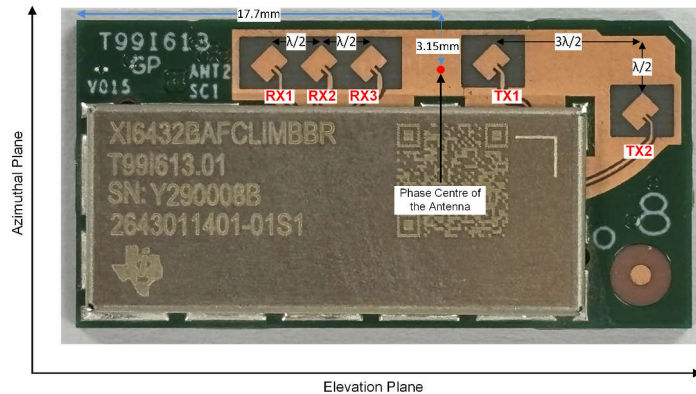

Figure 5-2. 2D Antenna Patch Array Geometry

Figure 5-3 shows the geometry of the virtual antenna array with each index depicting multiplication factor for $\lambda/2$. Position 0, 1, and 2 represents placement of virtual antenna originated from combination of all 3 RX (RX1, RX2, RX3) and TX1. Position 3, 4, and 5 represents placement of virtual antenna originated from combination of all 3 RX (RX1, RX2, RX3) and TX2.

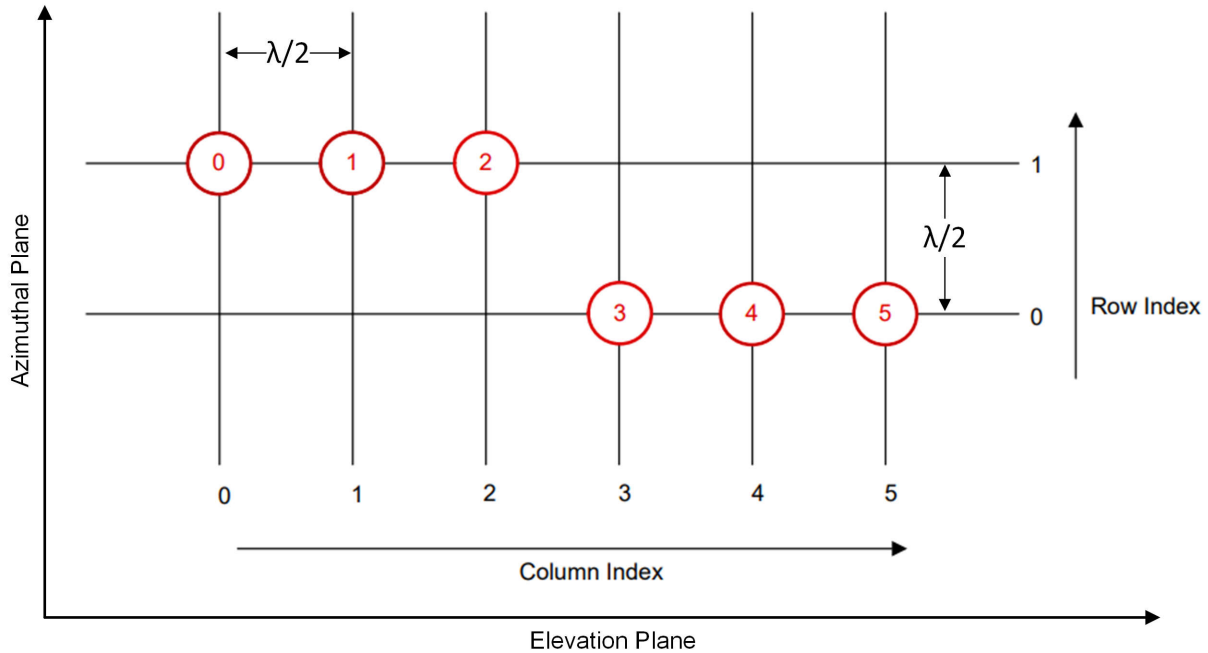

Figure 5-3. 2D Antenna - Virtual Array

The virtual antenna forms a two dimensional array with six elements in the azimuth and two elements in the elevation. The six elements in the azimuth direction, yields an angular resolution of 19 degrees in azimuthal plane. This enables 3-dimensional detection capability of the mmWave sensor.

5.9 Antenna Gain Plot

This section depicts transmitter and receiver normalized antenna loopback gain plot in azimuth and elevation planes

5.9.1 Measured Azimuth Loopback Plot

Figure 5-4 shows typical antenna loopback plots for all transmitter receiver pairs in Azimuth plane. The Y axis shows the normalized antenna loopback normalized gain in dB and X axis shows the angle in degrees.

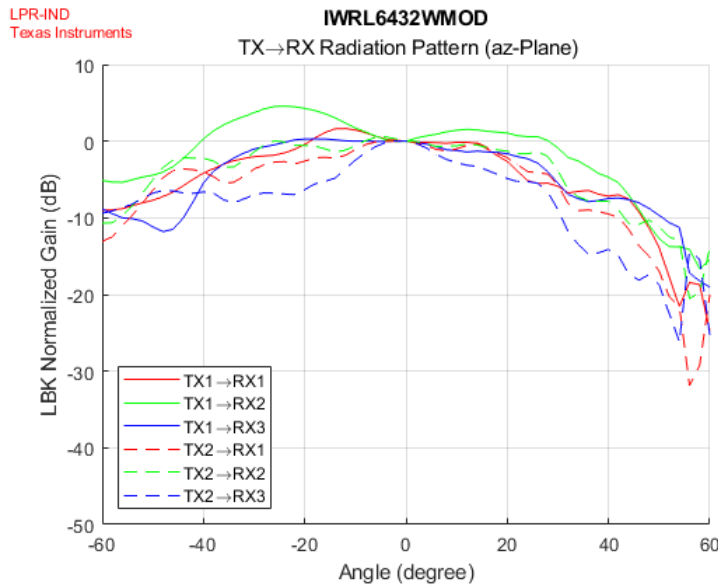

Figure 5-4. Measured Antenna Loopback Plot in Azimuth Plane

5.9.2 Measured Elevation Loopback Plot

Figure 5-5 shows typical antenna loopback plots for all transmitter and receiver pairs in Elevation plane. The Y axis shows the normalized antenna loopback normalized gain in dB and X axis shows the angle in degrees.

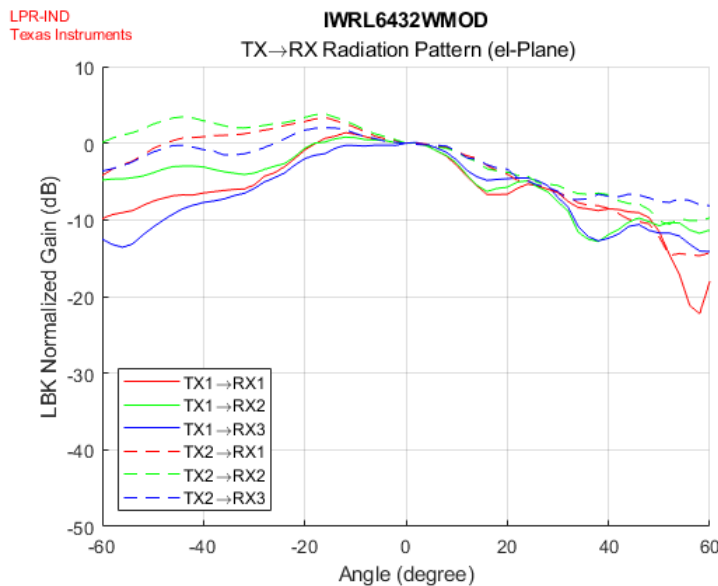

Figure 5-5. Measured Antenna Loopback Plot in Elevation Plane

5.10 Thermal Resistance Characteristics

Table 5-3. Thermal Resistance Characteristics for QFM Package [MBB0030A]

THERMAL METRICS ⁽¹⁾		°C/W ⁽²⁾⁽³⁾
$R\theta_{JC}$	Junction-to-case (Top)	29.0
$R\theta_{JB}$	Junction-to-board	21.6
$R\theta_{JA}$	Junction-to-free air	34.8
Ψ_{siJT}	Junction-to-top	18.3
Ψ_{siJB}	Junction-to-board	21.4

- For more information about traditional and new thermal metrics, see [Semiconductor and IC Package Thermal Metrics](#).
- °C/W = degrees Celsius per watt.
- These values are based on a JEDEC-defined 2S2P system (with the exception of the Theta JC [$R\theta_{JC}$] value, which is based on a JEDEC-defined 1S0P system) and will change based on environment as well as application. For more information, see these EIA/JEDEC standards:
 - JESD51-2, *Integrated Circuits Thermal Test Method Environmental Conditions - Natural Convection (Still Air)*
 - JESD51-3, *Low Effective Thermal Conductivity Test Board for Leaded Surface Mount Packages*
 - JESD51-7, *High Effective Thermal Conductivity Test Board for Leaded Surface Mount Packages*
 - JESD51-9, *Test Boards for Area Array Surface Mount Package Thermal Measurements*

5.11 Timing and Switching Characteristics

5.11.1 Power Supply Sequencing and Reset Timing

The IWRL6432WMOD device expects all external voltage rails to be stable before nRESET release. Figure 5-6 describes the device wake-up sequence.

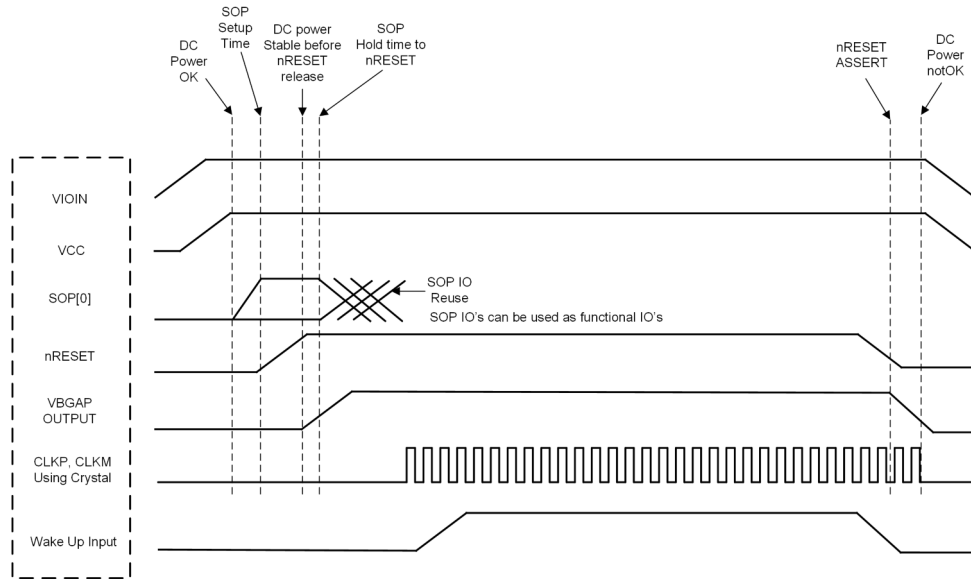

Figure 5-6. Module Wake-up Sequence

5.11.2 MultiChannel buffered / Standard Serial Peripheral Interface (McSPI)

The McSPI module is a multichannel transmit/receive, controller/peripheral synchronous serial bus

5.11.2.1 SPI Timing Conditions

Table 5-4 presents timing conditions for McSPI

Table 5-4. McSPI Timing Conditions

		MIN	TYP	MAX	UNIT
Input Conditions					
t_R	Input rise time	1		3	ns
t_F	Input fall time	1		3	ns
Output Conditions					
C_{LOAD}	Output load capacitance	2		15	pF

5.11.2.2 SPI—Peripheral Mode

5.11.2.2.1 Timing and Switching Requirements for SPI - Peripheral Mode

Table 5-5 and Table 5-6 present timing requirements for SPI -Peripheral Mode.

Table 5-5. SPI Timing Requirements - Peripheral Mode

NO.(1) (3)	PARAMETER	DESCRIPTION	MIN	MAX	UNIT
SS1	$t_c(SPI_{CLK})$	Cycle time, SPI_CLK	24.6		ns
SS2	$t_w(SPI_{CLKL})$	Typical Pulse duration, SPI_CLK low	$0.45 \cdot P_2$		ns
SS3	$t_w(SPI_{CLKH})$	Typical Pulse duration, SPI_CLK high	$0.45 \cdot P_2$		ns
SS4	$t_{su}(SIMO-SPI_{CLK})$	Setup time, SPI_D[x] valid before SPI_CLK active edge	3		ns
SS5	$t_h(SPI_{CLK}-SIMO)$	Hold time, SPI_D[x] valid after SPI_CLK active edge	1		ns
SS8	$t_{su}(CS-SPI_{CLK})$	Setup time, SPI_CS[x] valid before SPI_CLK first edge	5		ns

Table 5-5. SPI Timing Requirements - Peripheral Mode (continued)

NO.(1) (3)	PARAMETER	DESCRIPTION	MIN	MAX	UNIT
SS9	$t_{h(SPICLK-CS)}$	Hold time, SPI_CS[x] valid after SPI_CLK last edge	5		ns
SS10	sr	Input Slew Rate for all pins	1	3	ns
SS11	Cb	Capacitive load on D0 and D1	2	15	pF

Table 5-6. SPI Switching Characteristics Peripheral Mode

NO.	PARAMETER	DESCRIPTION	MIN	MAX	UNIT
SS6	$t_{d(SPICLK-SOMI)}$	Delay time, SPI_CLK active edge to McSPI_somi transition	0	5.77	ns
SS7	$t_{sk(CS-SOMI)}$	Delay time, SPI_CS[x] active edge to McSPI_somi transition	5.77		ns

1. P = This timing applies to all configurations regardless of SPI_CLK polarity and which clock edges are used to drive output data and capture input data.
2. P = SPICLK period.
3. PHA = 0; SPI_CLK phase is programmable with the PHA bit of the SPI_CH(i)CONF register.

5.11.2.2.2 Timing and Switching Characteristics for SPI Output Timings—Secondary Mode

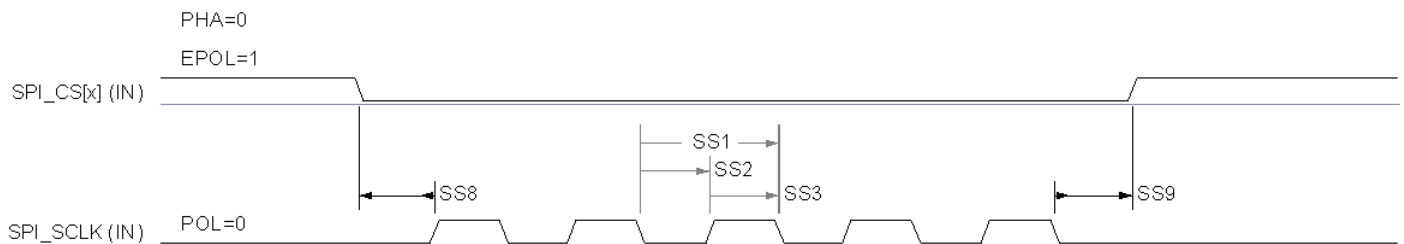

Figure 5-7. SPI Timing - Peripheral mode Receive

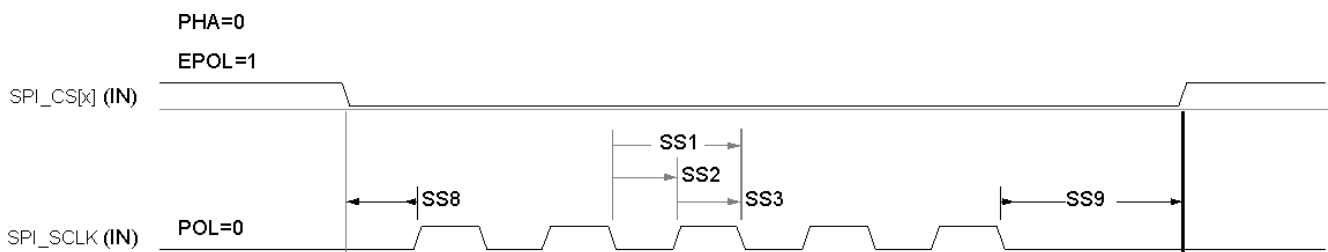

Figure 5-8. SPI Timing - Peripheral mode Transmit

5.11.2.3 SPI Protocol

This section describes the low-level SPI configuration, packet structure, and transfer sequencing required for host-to-module communication. Integrators using the mmWaveULink library do not need to implement this protocol manually — it is handled internally.

Parameter	Value	Notes
Controller	HOST MCU	Host MCU is always SPI controller
Peripheral	IWRL6432WMOD	Single peripheral on the bus
Mode	0 (CPOL:0 , CPHA:0)	Data sampled on rising edge, shifted on falling edge
Maximum Frequency	15MHz	Reduce to 10MHz if signal integrity issues are observed
Data Width	16 bits (MSB first)	MSB first
Endianness	Little	Applies to multi-byte fields within the packet
CS Polarity	Active Low	Standard SPI chip select

5.11.2.3.1 Data Format for Host Communication over SPI

The SPI packet format consists of the SPI header and SPI command/ response data.

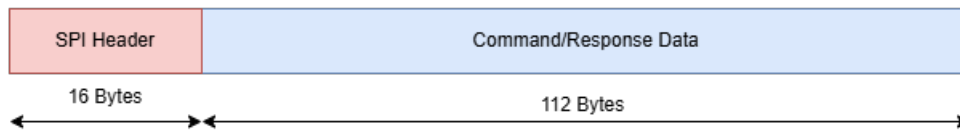

Figure 5-9. SPI Data Format

The SPI header of 16 bytes is further divided with CRC-32 for message authentication , command or response Identifier, long and short message size with few reserved bytes.

Byte Offset	Field Name	Size (bytes)	Description
0-3	CRC-32	4	CRC-32 computed over bytes 4–15 of the header and the full payload. Used for message authentication.
4-5	Message ID	2	Identifies the command (host-to-module) or response (module-to-host). See API command table.
6-7	Short Message Length	2	Length of the payload when payload is 255 bytes or less. Set to 0xFFFF if long length is used.
8-11	Long Message Length	4	Length of the payload when payload exceeds 255 bytes. Set to 0x00000000 if short length is used.
12-15	Reserved	4	Set to 0x00000000. Must not be modified.



Figure 5-10. SPI Header Format

The SPI command/response is further divided to command header and variable length command/response. The max variable length can be 106bytes.

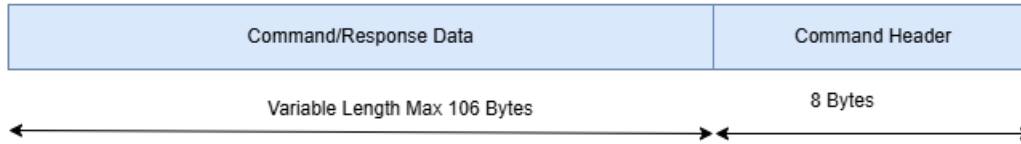

Figure 5-11. SPI Command Format

Byte Offset	Field Name	Size (bytes)	Description
0-1	Command/Response Code	2	Opcode identifying the specific API command or response type.
2-3	Payload Sub-length	2	Length of the variable data field that follows.
4-N	Variable Data	0-102	Command arguments or response data. Format is command-specific. Maximum 102 bytes.

Note

The combined header (16 bytes) and payload (max 106 bytes) make the maximum SPI transaction size 122 bytes. Buffers allocated in the host MCU must accommodate this maximum.

5.11.2.3.2 Typical Sequence Diagram

Below is a typical API sequence that the Host MCU application should follow for communicating with the module.

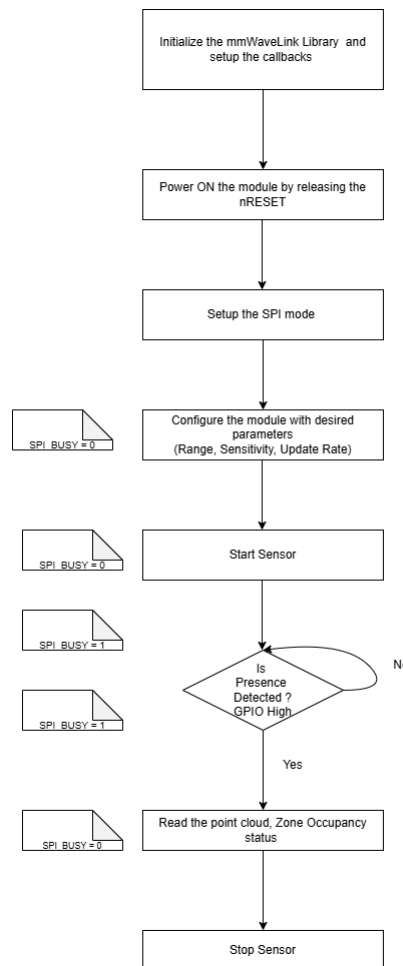

Figure 5-12. Typical Sequence Diagram

5.11.3 Dedicated Input/Output

This section highlights the timing and switching characteristics for module wakeup input and presence indication output.

5.11.3.1 Switching Characteristics for Output Timing versus Load Capacitance (C_L)

Table 5-7 lists the switching characteristics of output timing relative to load capacitance.

Table 5-7. Switching Characteristics for Output Timing versus Load Capacitance (C_L)

PARAMETER ⁽¹⁾		TEST CONDITIONS		UNIT
t_r	Max rise time	$C_L = 20\text{pF}$	3.3	ns
		$C_L = 50\text{pF}$	7.2	
		$C_L = 75\text{pF}$	10.5	
t_f	Max fall time	$C_L = 20\text{pF}$	3.1	ns
		$C_L = 50\text{pF}$	6.6	
		$C_L = 75\text{pF}$	9.6	

1. The rise/fall time is measured as the time taken by the signal to transition from 10% and 90% of VIOIN voltage.

5.11.4 Serial Communication Interface (SCI)

Note

The UART interface are used for uDFP patch updates only. This is not the application interface.

5.11.4.1 SCI Timing Requirements

		MIN	TYP	MAX	UNIT
f(baud)	Supported baud rate at 20pF		115.2 ⁽¹⁾		kBaud

1. Maximum supported standard baud rate.

6 Detailed Description

6.1 Overview

Texas Instruments' radar module IWRL6432WMOD is a compact 31mm × 15.5mm module that integrates a 60GHz patch antenna, on-board power management, flash memory, passives and crystal, eliminating the need for specialized mmWave system design expertise while providing simple software configuration options for range, sensitivity, and regions of interest. The module is distinguished by its comprehensive certification with FCC, RED, MIC that eliminates cost and effort for certification at the end product. Additionally the module provides either SPI based point cloud data outputs or GPIO based presence indication which aids flexible implementation. By addressing customer readiness challenges and enabling autonomous operation across applications such as motion sensing, occupancy detection, and smart home devices, this TI-designed, supported, and distributed device significantly reduces development complexity and accelerates time-to-market for customers seeking to embed mmWave radar sensor capabilities in their products.

6.1.1 Module Images



Figure 6-1. Top Side of the Module

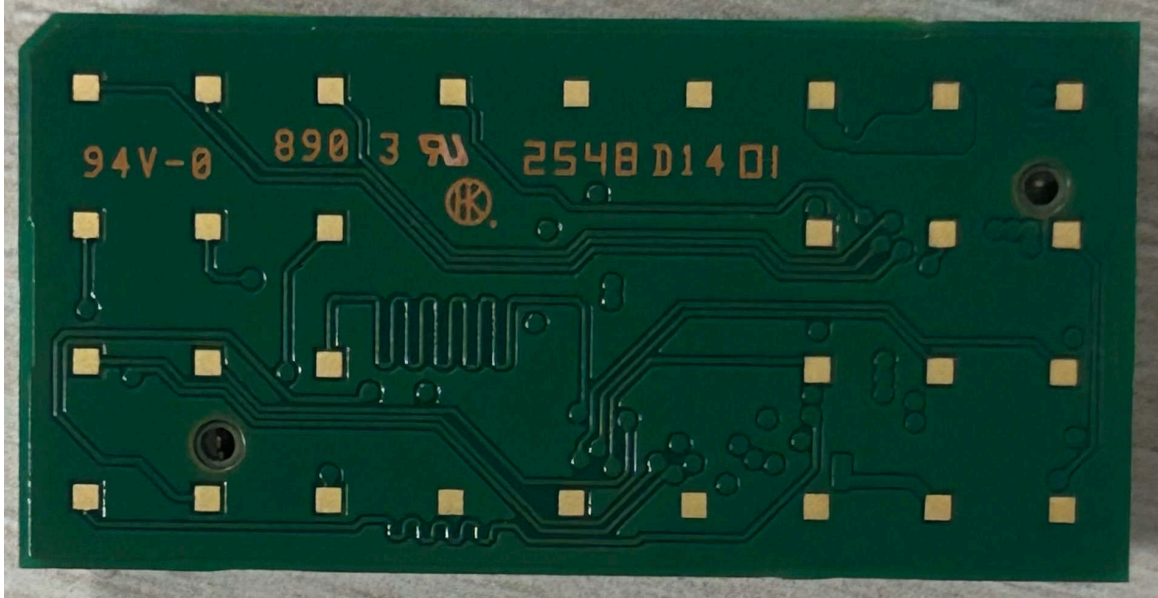

Figure 6-2. Bottom Side of the Module

6.2 Functional Block Diagram

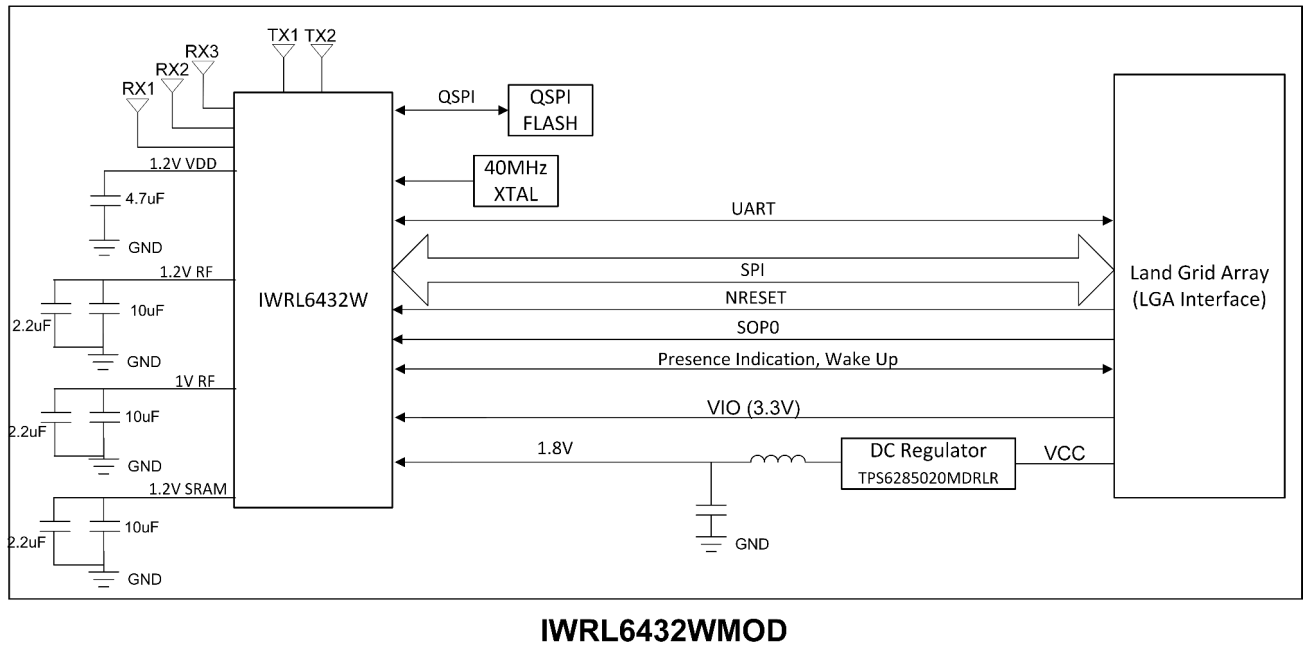

Figure 6-3. Functional Block Diagram

6.3 Subsystems

6.3.1 Host Interface

This section software integration guidelines for interfacing an external Microcontroller Unit (MCU) with the IWRL6432WMOD mmWave radar module. It covers the hardware interface signals, operating modes, SPI communication protocol, firmware library integration, API usage patterns, and recommended coding practices.

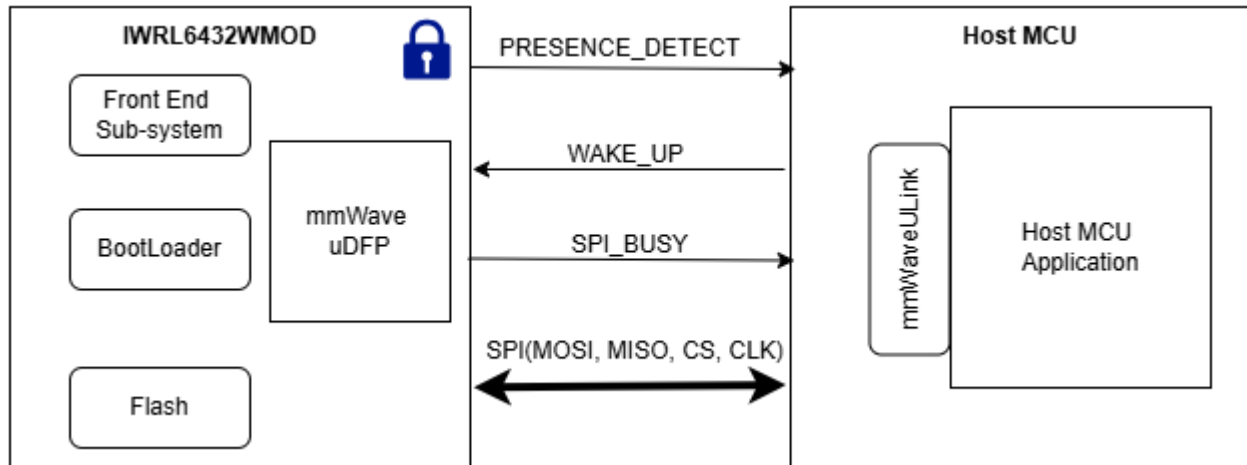

Figure 6-4. Host Interface

6.3.1.1 Interface Signal Description

The IWRL6432WMOD communicates with an external host MCU through a set of dedicated hardware signals. The primary data path is a synchronous SPI bus. Additional GPIO signals coordinate power state and interrupt-driven communication flow.

Signal	Direction (from HOST)	Type	Description
SPI (MOSI/MISO/SCLK/CS)	Bidirectional	SPI Bus	Primary synchronous serial interface. Host MCU is SPI Controller; IWRL6432WMOD is SPI Peripheral.
SPI_BUSY	Input to Host	GPIO — Output from Module	Active HIGH. Asserted by the module when it is processing a command and cannot accept new SPI transactions. Host must poll or interrupt on this before initiating transfers.
PRESENCE_DETECT	Input to Host	GPIO — Output from Module	In Autonomous and Multi-Zone modes: HIGH indicates Presence detected. In Verbose mode: toggles to indicate End-of-Frame, allowing host to synchronize data reads.
WAKE_UP	Output from Host	GPIO — Input to Module	Active HIGH. Host must assert before any SPI API transaction and de-assert after the transaction completes. Prevents the module from entering Deep Sleep during communication. The WAKE_UP (Module Wakeup Input) should be pulled LOW using pull down resistor (lower than 10KOhm) on customer hardware.
nRESET	Output from Host	GPIO — Input to Module	Active LOW. Host releases (de-asserts) this signal to power on the module. Must remain HIGH during normal operation.

Note

SPI_BUSY must be checked for LOW before asserting CS and beginning any SPI transfer. Initiating a transfer while SPI_BUSY is HIGH may corrupt the transaction and cause undefined module behavior.

6.3.1.2 Operating Modes

The IWRL6432WMOD operates in 3 different modes :

1. Autonomous Mode
2. Multi-zone Mode
3. Verbose Mode

Selecting the correct mode determines whether a host MCU is required, what data is available over SPI, and how configuration is stored. The mode is selected at firmware load time and cannot be changed at runtime without a full reset. Below table lists the differences in these operating mode.

	Autonomous Mode	Multi-Zone Mode	Verbose mode
Need Host MCU	No	Yes	Yes
Host MCU Interface	Not Applicable	SPI	SPI
Output information from IWRL6432WMOD	Binary data (Presence /No Presence GPIO indication)	Presence/No Presence binary data. Point cloud, zone-occupancy status for each individual zone	Presence/No Presence binary data. Point cloud, zone-occupancy status for each individual zone
PRESENCE_DETECT Output functionality	Indicate Presence	Indicate Presence	Indicate End of Frame
Configuration Storage	External Flash (in IWRL6432WMOD)	Host MCU	Host MCU
Suitable For	Simple standalone detection without MCU	Zoned presence detection with MCU overhead	Full radar data capture and custom processing

6.3.2 Device Firmware

The IWRL6432WMOD comes with a presence and motion detection software that is pre-programmed in the external flash that is part of the module. The module can be configured to set of desired configuration based on the customer use-cases for max range, detection sensitivity , motion sensitivity and region of interest using set of simple APIs that are defined as part of the uDevice Firmware Package ([MMWAVE-UDFP-APPSW](#)).

More details of the APIs and the sequence to be followed to configure the module can be found in the documentation available in the [MMWAVE-UDFP-APPSW](#) package

<MMWAVE_UDFP_INSTALL_PATH>\Host\mmWaveULink_Interface_Control_Document.pdf

7 Device Certification

The IWRL6432WMOD module from TI is modularly approved for FCC, ETSI/CE, and Japan MIC. TI customers who build products based on the IWRL6432WMOD can benefit by reducing the test cost and time to market.

Note

The FCC ID must be placed in both the user manual and on the package. The module contains the FCC ID and marking in 4 pt. font.

Table 7-1. Device Certification

REGULATORY BODY	SPECIFICATION	ID(When Applicable)
FCC (USA)	Part 15.255 + MPE FCC RF Exposure	2AX.JSIWRL6432BAFCLI
ETSI/CE (European Union)	EN 305 550-2 v1.2.1	
	EN 301 489-1 v2.2.3	
	EN 301 489-51 v2.1.1	
	EN 62368-1:2020+A11:2020	
MIC (Japan)	JRL 2-1-8	

Note

Customers operating the device within Japan must enable the “MIC Compliant Mode” bit. Failure to do so will void the certification of the device.

7.1 FCC Certification and Statement

The IWRL6432WMOD module from TI is approved under the FCC as a single-modular transmitter. The modules are radio modules that carry an FCC modular grant. Users are cautioned that changes or modifications not expressly approved by the part responsible for compliance could void the authority of the user to operate the equipment.

This device complies with Part 15 of the FCC rules. Operation is subject to two conditions:

1. This device may not cause harmful interference.
2. This device must accept any interference received, including interference that may cause undesired operation of the device.

Note

FCC RF Radiation Exposure Statement: This equipment complies with FCC radiation exposure limits set forth for an uncontrolled environment. End users must follow the specific operating instructions to satisfy RF exposure limits. This transmitter must not be collocated or operate with any other antenna or transmitter.

7.2 ETSI/CE

The IWRL6432WMOD modules conform to the EU Radio Equipment Directive. For further details, see the full text of the EU Declaration of Conformity for the IWRL6432WMOD devices.

Note

This device complies with the RF Exposure Limits given in Council Recommendation 1999/519/EC for any separation distance greater than or equal to 20 cm under all modes of operation. Users should maintain at least 20 cm of separation between humans and the device when in operation.

8 Applications, Implementation, and Layout

Note

Information in the following Applications section is not part of the TI component specification, and TI does not warrant its accuracy or completeness. TI's customers are responsible for determining suitability of components for their purposes. Customers should validate and test their design implementation to confirm system functionality.

8.1 Application Information

8.1.1 Typical Application

The module supports two system topologies.

- Topology 1: Autonomous mode, with ability to send Presence Detect via GPIO
- Topology 2: Secondary Device mode, under control of external MCU

8.1.1.1 Autonomous Mode

In Autonomous mode, the radar's chirping configuration, which sets the range, sensitivity and user-defined detection parameters for the radar, are pre-stored in the module serial flash. The application software boots up and reads the configuration from the flash and gives a Presence/No Presence indication via GPIO (Presence Detect GPIO) . For example, this GPIO can be used to turn ON/OFF a simple lighting relay circuit. Refer to [MMWAVE-UDFP-APPSW](#) or [BP-IWRL6432WMOD](#) user guide for steps to store the configuration to flash using SPI.

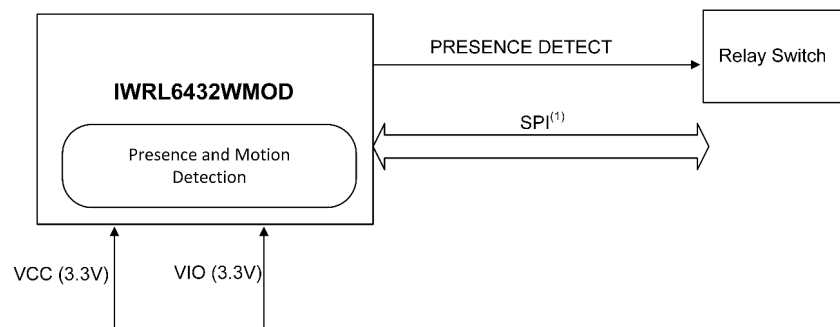

Figure 8-1. Autonomous Mode

1. Only for storing the configuration on to the flash. The interface shall be used only once during the production.

8.1.1.2 Secondary Device Mode

In Secondary Device mode, the IWRL6432WMOD is interfaced with an external Host MCU . SPI is the primary host communication interface to configure the module. The host is required to integrate the "mmWaveuLink/ uLINK" library to control the module in its system software. The host sends the configuration (SPI Messages) to the module through the SPI interface. The module provides presence detection through a dedicated GPIO (Presence Indication Output) . In this mode the module can also send out point cloud information to the host via the same SPI interface. The host can interpret the point cloud data to perform higher order processing like tracking.

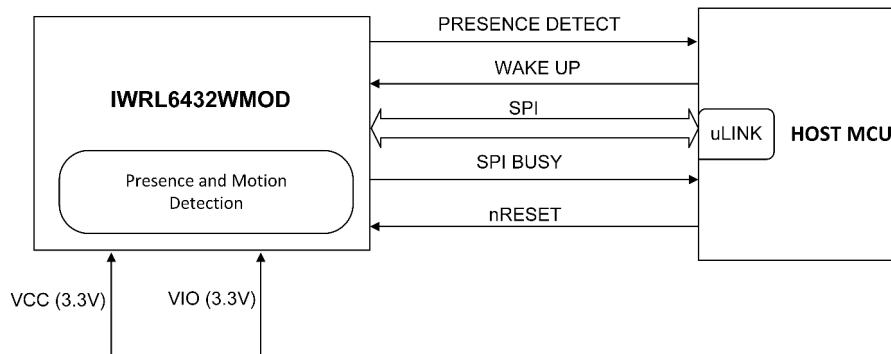

Figure 8-2. Secondary Device Mode

8.2 Test Results

In an open space the module was placed for the test. The configuration used for this test is elaborated in [Figure 8-3](#).

Table 8-1. Test Results

Azimuthal Angle	Presence Detection
0°	15m
+45°	13m
-45°	12m
+60°	9m
-60°	7m

Sensor Configuration

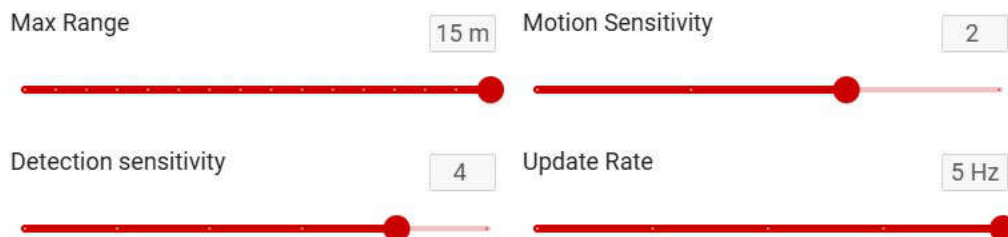

Figure 8-3. Test Configuration

9 Device and Documentation Support

9.1 Device Nomenclature

To designate the stages in the product development cycle, TI assigns prefixes to the part numbers of all microprocessors (MPUs) and support tools. Each device has one of three prefixes: X, P, or null (no prefix) (for example, *IWRL6432W*). Texas Instruments recommends two of three possible prefix designators for its support tools: TMDX and TMDS. These prefixes represent evolutionary stages of product development from engineering prototypes (TMDX) through fully qualified production devices and tools (TMDS).

Device development evolutionary flow:

- X** Experimental device that is not necessarily representative of the final device's electrical specifications and may not use production assembly flow.
- P** Prototype device that is not necessarily the final silicon die and may not necessarily meet final electrical specifications.
- null** Production version of the silicon die that is fully qualified.

Support tool development evolutionary flow:

- TMDX** Development-support product that has not yet completed Texas Instruments internal qualification testing.
- TMDS** Fully-qualified development-support product.

X and P devices and TMDX development-support tools are shipped against the following disclaimer:

"Developmental product is intended for internal evaluation purposes."

Production devices and TMDS development-support tools have been characterized fully, and the quality and reliability of the device have been demonstrated fully. TI's standard warranty applies.

Predictions show that prototype devices (X or P) have a greater failure rate than the standard production devices. Texas Instruments recommends that these devices not be used in any production system because their expected end-use failure rate still is undefined. Only qualified production devices are to be used.

TI device nomenclature also includes a suffix with the device family name. This suffix indicates the package type (for example, MBB0030A), the temperature range (for example, blank is the default commercial temperature range). [Figure 9-1](#) provides a legend for reading the complete device name for any *IWRL6432WMOD* device.

For orderable part numbers of *IWRL6432WMOD* devices in the MBB0030A package types, see the Package Option Addendum of this document (when available), the TI website (www.ti.com), or contact your TI sales representative.

For additional description of the device nomenclature markings on the die, see the [Device Marking](#).

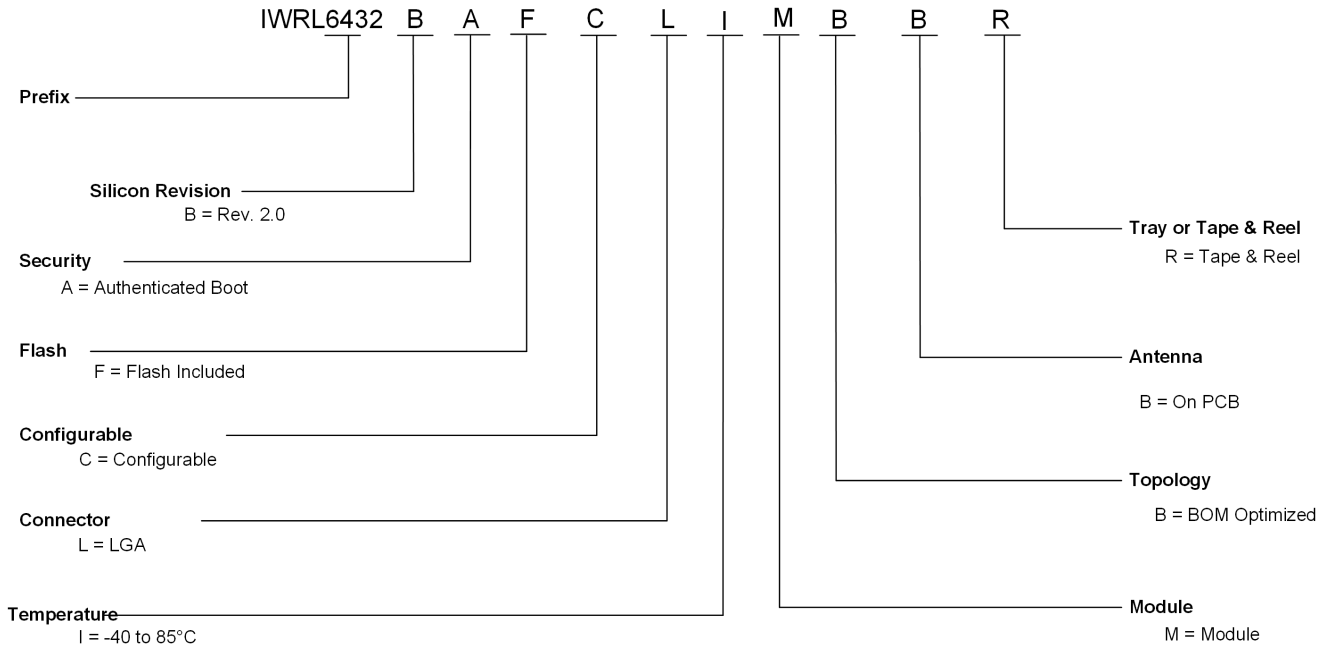

Figure 9-1. Production Device Nomenclature

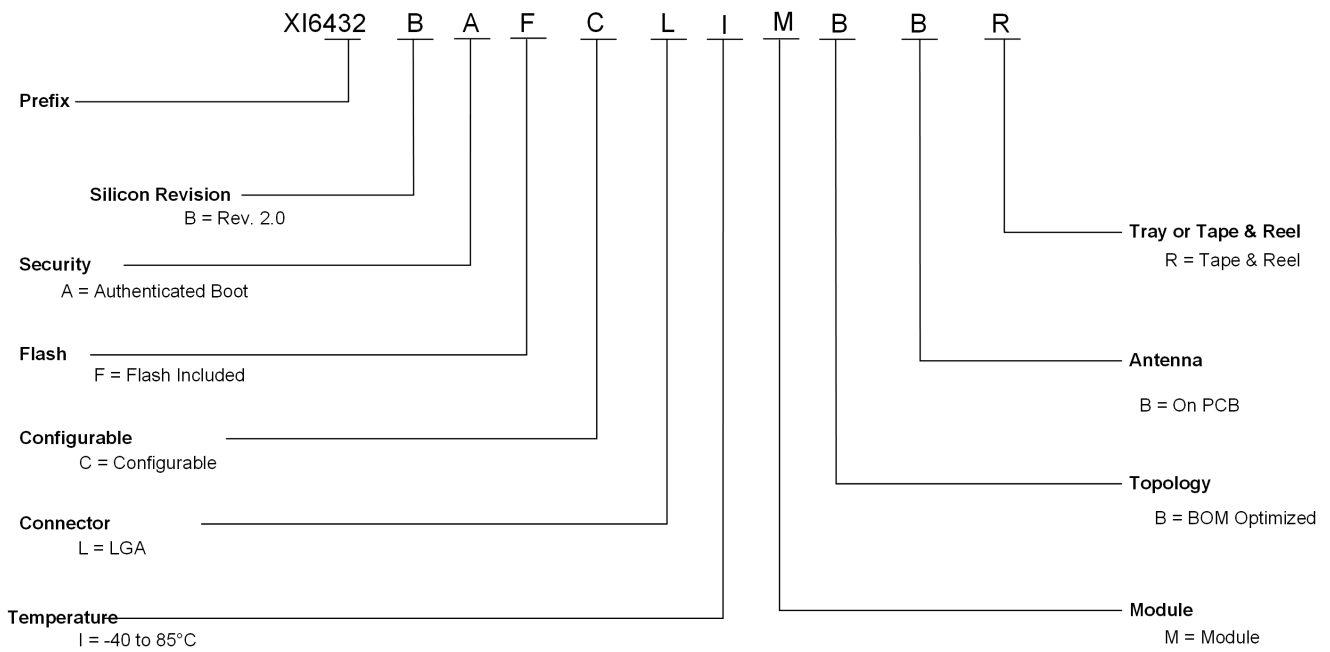

Figure 9-2. Pre-production Device Nomenclature

9.2 Device Marking

Figure 9-3 shows an example of the IWRL6432WMOD Radar Device's package symbolization.



Figure 9-3. Example of Device Part Markings

This identifying number contains the following information:

- **Line 1:** Orderable Part Number
- **Line 2:** Generic Part Number
- **Line 3:** Barcode
- **Line 4:** Serial Number
- **Line 5:** TI Logo
- **Line 5:** Manufacturer Part Number
- **Line 6:** FCC ID number

MARKING	DESCRIPTION
IWRL6432BAFCLIMBBR	TI Orderable Part Number
IWRL6432WMOD	TI Generic Part Number
SN: XXXXXXXX	Serial Number: Reserved for TI Use
T99I613.01	Manufacturer Part Number
Barcode	Barcode Identifier
QR	Product Page
2AXJSIWRL6432BAFCLI	FCC ID number

9.3 Documentation Support

To receive notification of documentation updates, navigate to the device product folder on [ti.com](https://www.ti.com). Click on *Notifications* to register and receive a weekly digest of any product information that has changed. For change details, review the revision history included in any revised document.

The current documentation that describes the peripherals, and other technical collateral follows.

- [IWRL6432WMOD device datasheet](#)

9.4 Support Resources

[TI E2E™ support forums](#) are an engineer's go-to source for fast, verified answers and design help—straight from the experts. Search existing answers or ask your own question to get the quick design help you need.

Linked content is provided "AS IS" by the respective contributors. They do not constitute TI specifications and do not necessarily reflect TI's views; see TI's [Terms of Use](#).

9.5 Trademarks

E2E™ is a trademark of Texas Instruments.
All trademarks are the property of their respective owners.

9.6 Electrostatic Discharge Caution



This integrated circuit can be damaged by ESD. Texas Instruments recommends that all integrated circuits be handled with appropriate precautions. Failure to observe proper handling and installation procedures can cause damage.

ESD damage can range from subtle performance degradation to complete device failure. Precision integrated circuits may be more susceptible to damage because very small parametric changes could cause the device not to meet its published specifications.

9.7 Glossary

TI Glossary	This glossary lists and explains terms, acronyms, and definitions.
-----------------------------	--

10 Reflow Information

This section provides information about reflow guidelines for reflow soldering.

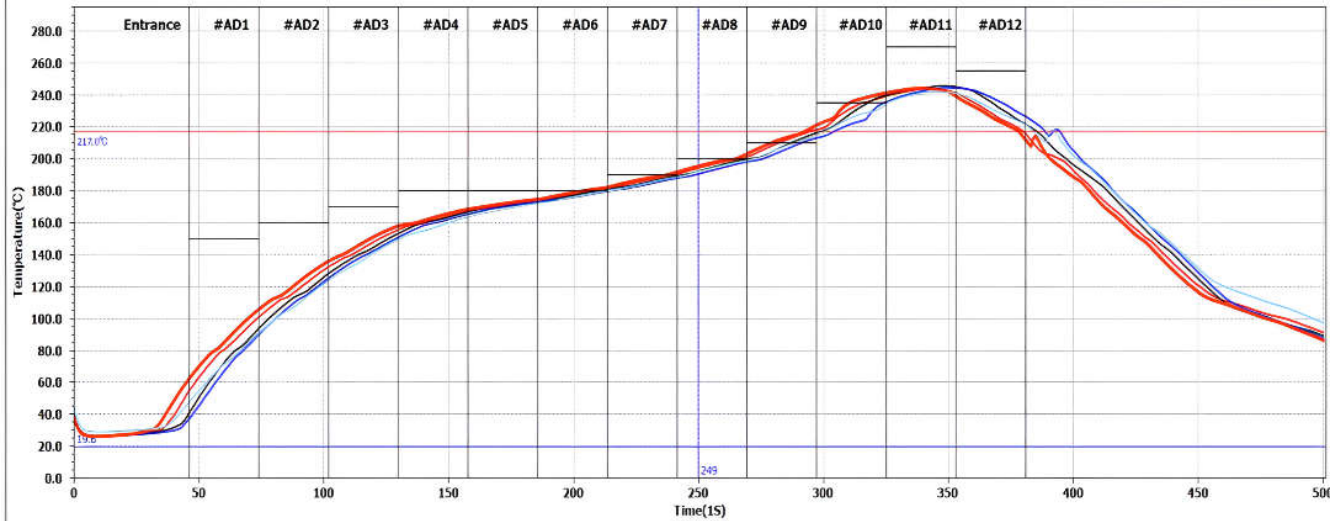

Figure 10-1. Module Reflow Profile

PARAMETER		MIN	TYP	MAX	UNIT
Pre-Heat/ Soak time (t_s)	150°C (T_{smin})- 180°C (T_{smax})	60		120	sec
Reflow	Over 217°C (T_L)	50		90	sec
Ramp-Up Rate(T_L to T_P)		0		3	°C/sec
Peak Temperature (T_P)		240		250	°C
Ramp-Down Rate (T_P to T_L)		-3		0	°C/sec
O ₂ Content				3000	PPM

- t_s - Soak Time
- T_{smin} - Minimum Soak Temperature
- T_{smax} - Maximum Soak Temperature
- T_L - Liquidous Temperature
- T_P - Peak Temperature

11 Revision History

DATE	REVISION	NOTES
December 2025	*	Initial Release
May 2026	A	RTM Release

Changes from December 31, 2025 to June 4, 2026 (from Revision * (December 2025) to Revision A (June 2026))

	Page
• Features: Certification status updated.....	1
• Applications: Added Robotics.....	1
• Description: Description updated.....	2
• Packaging Information: Dimensions updated.....	2
• Typical Power Consumption Numbers: Section added.....	6
• Antenna Radiation Pattern: Loopback radiation pattern updated.....	9
• SPI Protocol: New section added.....	13
• Detailed Description: Overview updated.....	16

IWRL6432WMODSWRS350A – DECEMBER 2025 – REVISED JUNE 2026

- Host Interface: Section updated..... 18
- Device certification: Section added..... 20
- Device Marking: Marking updated for production part..... 25

12 Mechanical, Packaging, and Orderable Information

The following pages include mechanical, packaging, and orderable information. This information is the most current data available for the designated devices. This data is subject to change without notice and revision of this document. For browser-based versions of this data sheet, see the left-hand navigation.

MBB0030A

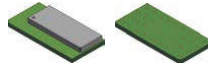

PACKAGE OUTLINE

QFM - 3.8 mm max height

QUAD FLATPACK MODULE - NO LEAD

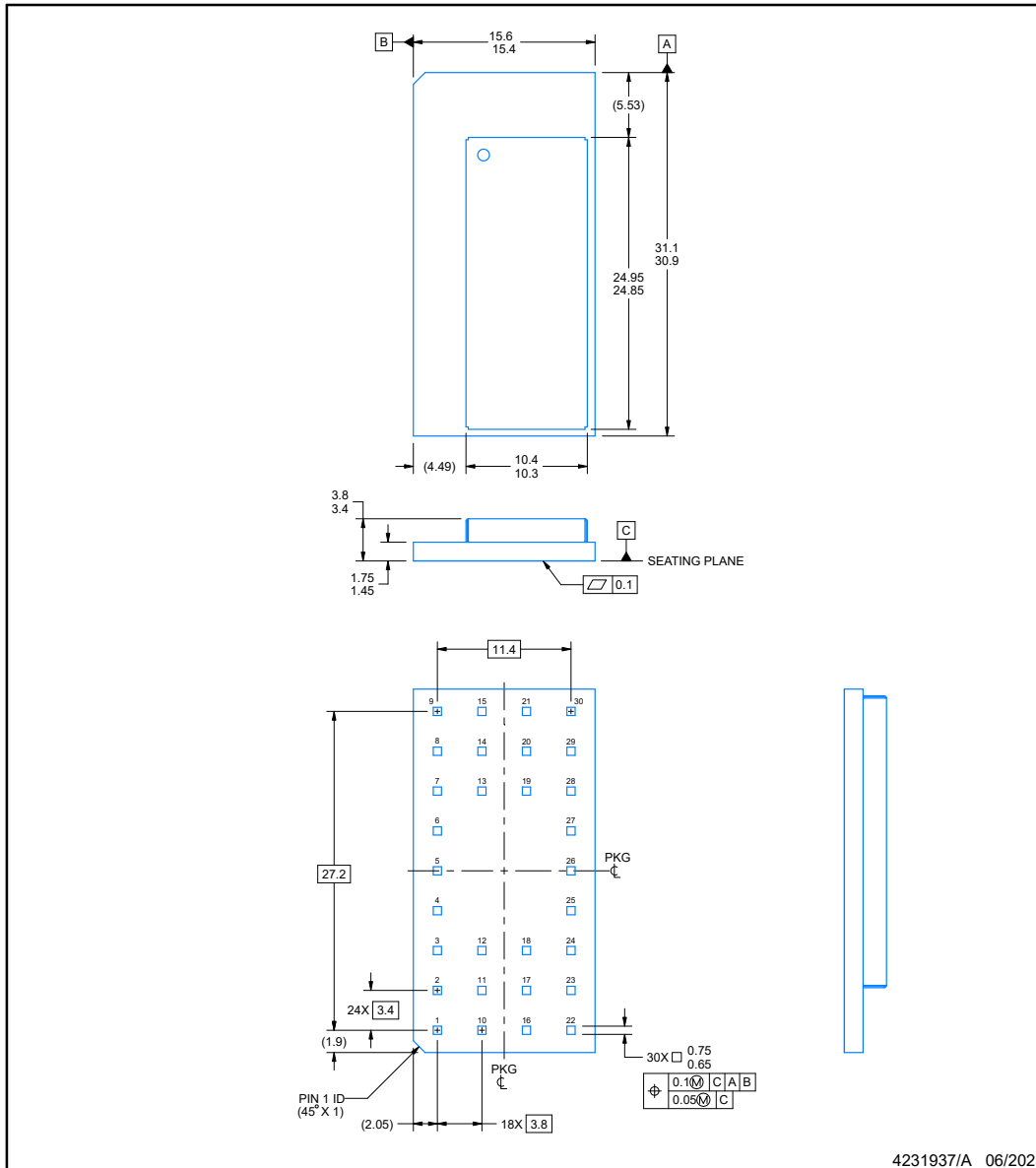

NOTES:

1. All linear dimensions are in millimeters. Any dimensions in parenthesis are for reference only. Dimensioning and tolerancing per ASME Y14.5M.
2. This drawing is subject to change without notice.

EXAMPLE BOARD LAYOUT

MBB0030A

QFM - 3.8 mm max height

QUAD FLATPACK MODULE - NO LEAD

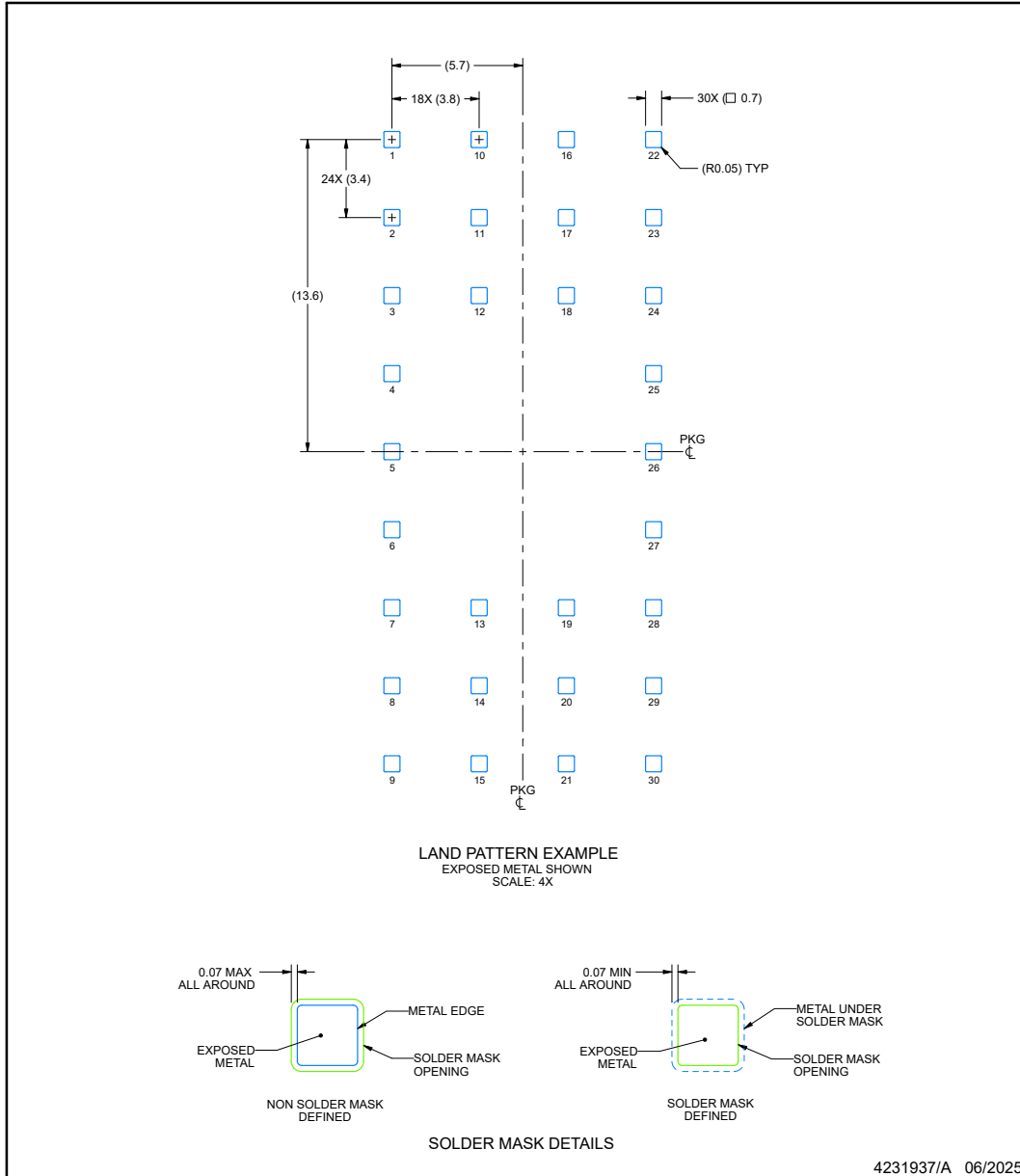

NOTES: (continued)

3. For more information, see Texas Instruments literature number SLUA271 (www.ti.com/lit/slua271).

EXAMPLE STENCIL DESIGN

MBB0030A

QFM - 3.8 mm max height

QUAD FLATPACK MODULE - NO LEAD

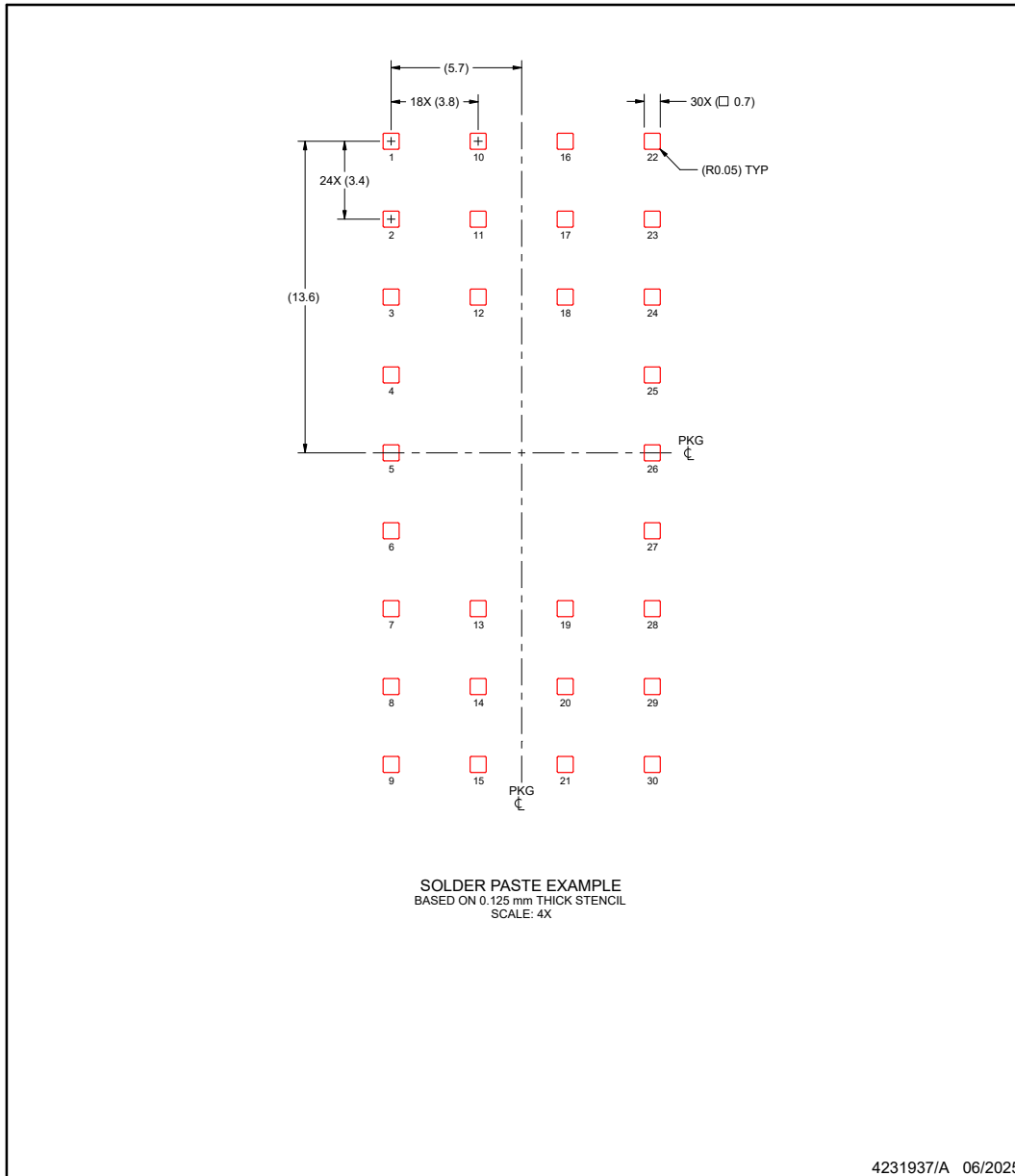

NOTES: (continued)

4. Laser cutting apertures with trapezoidal walls and rounded corners may offer better paste release. IPC-7525 may have alternate design recommendations.

PACKAGING INFORMATION

Orderable part number	Status (1)	Material type (2)	Package Pins	Package qty Carrier	RoHS (3)	Lead finish/ Ball material (4)	MSL rating/ Peak reflow (5)	Op temp (°C)	Part marking (6)
X16432BAFCLIMBBR	Active	Preproduction	QFM (MBB) 30	600 LARGE T&R	Exempt	Call TI	Call TI	-40 to 85	

(1) **Status:** For more details on status, see our [product life cycle](#).

(2) **Material type:** When designated, preproduction parts are prototypes/experimental devices, and are not yet approved or released for full production. Testing and final process, including without limitation quality assurance, reliability performance testing, and/or process qualification, may not yet be complete, and this item is subject to further changes or possible discontinuation. If available for ordering, purchases will be subject to an additional waiver at checkout, and are intended for early internal evaluation purposes only. These items are sold without warranties of any kind.

(3) **RoHS values:** Yes, No, RoHS Exempt. See the [TI RoHS Statement](#) for additional information and value definition.

(4) **Lead finish/Ball material:** Parts may have multiple material finish options. Finish options are separated by a vertical ruled line. Lead finish/Ball material values may wrap to two lines if the finish value exceeds the maximum column width.

(5) **MSL rating/Peak reflow:** The moisture sensitivity level ratings and peak solder (reflow) temperatures. In the event that a part has multiple moisture sensitivity ratings, only the lowest level per JEDEC standards is shown. Refer to the shipping label for the actual reflow temperature that will be used to mount the part to the printed circuit board.

(6) **Part marking:** There may be an additional marking, which relates to the logo, the lot trace code information, or the environmental category of the part.

Multiple part markings will be inside parentheses. Only one part marking contained in parentheses and separated by a "-" will appear on a part. If a line is indented then it is a continuation of the previous line and the two combined represent the entire part marking for that device.

Important Information and Disclaimer: The information provided on this page represents TI's knowledge and belief as of the date that it is provided. TI bases its knowledge and belief on information provided by third parties, and makes no representation or warranty as to the accuracy of such information. Efforts are underway to better integrate information from third parties. TI has taken and continues to take reasonable steps to provide representative and accurate information but may not have conducted destructive testing or chemical analysis on incoming materials and chemicals. TI and TI suppliers consider certain information to be proprietary, and thus CAS numbers and other limited information may not be available for release.

In no event shall TI's liability arising out of such information exceed the total purchase price of the TI part(s) at issue in this document sold by TI to Customer on an annual basis.

EXAMPLE BOARD LAYOUT

MBB0030A

QFM - 3.8 mm max height

QUAD FLATPACK MODULE - NO LEAD

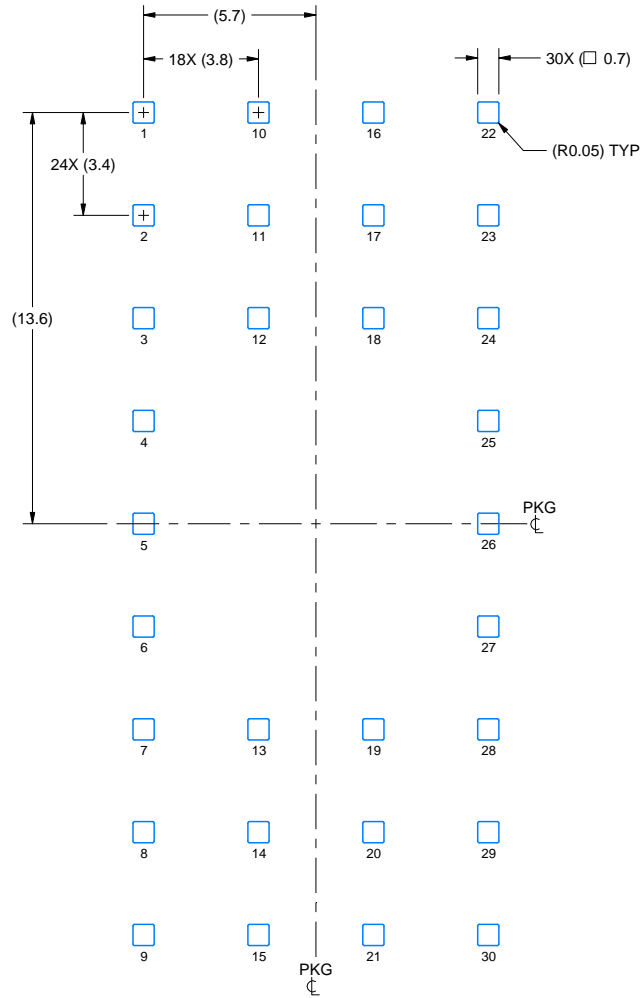

LAND PATTERN EXAMPLE
EXPOSED METAL SHOWN
SCALE: 4X

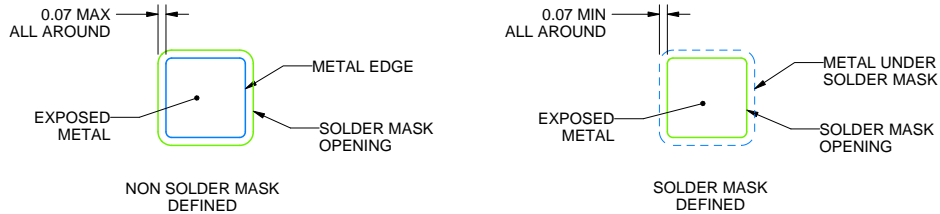

SOLDER MASK DETAILS

4231937/A 06/2025

NOTES: (continued)

3. For more information, see Texas Instruments literature number SLUA271 (www.ti.com/lit/sl原因271).

EXAMPLE STENCIL DESIGN

MBB0030A

QFM - 3.8 mm max height

QUAD FLATPACK MODULE - NO LEAD

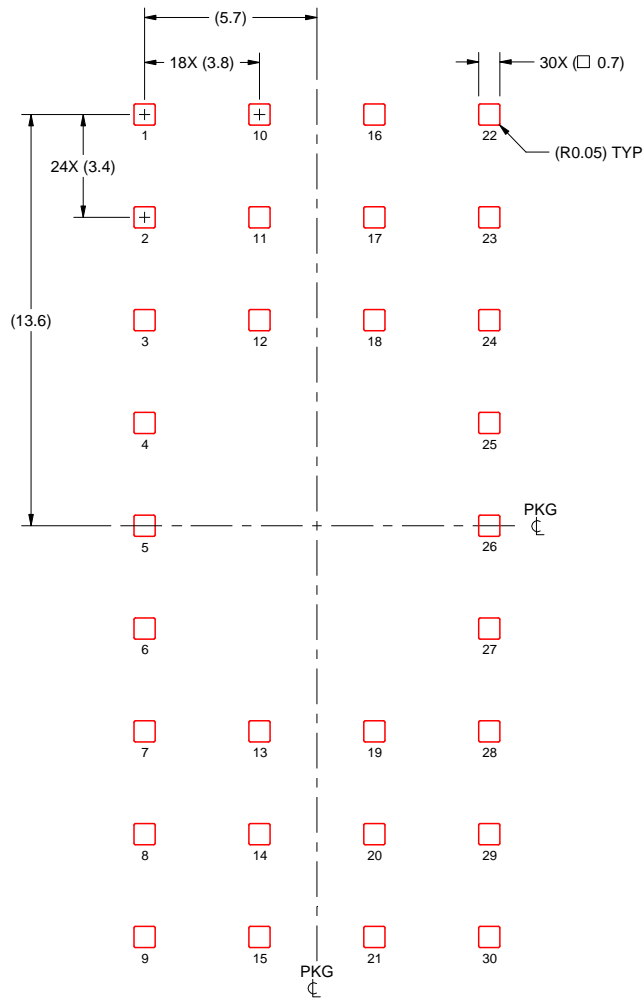

SOLDER PASTE EXAMPLE
BASED ON 0.125 mm THICK STENCIL
SCALE: 4X

4231937/A 06/2025

NOTES: (continued)

4. Laser cutting apertures with trapezoidal walls and rounded corners may offer better paste release. IPC-7525 may have alternate design recommendations.

IMPORTANT NOTICE AND DISCLAIMER

TI PROVIDES TECHNICAL AND RELIABILITY DATA (INCLUDING DATASHEETS), DESIGN RESOURCES (INCLUDING REFERENCE DESIGNS), APPLICATION OR OTHER DESIGN ADVICE, WEB TOOLS, SAFETY INFORMATION, AND OTHER RESOURCES "AS IS" AND WITH ALL FAULTS, AND DISCLAIMS ALL WARRANTIES, EXPRESS AND IMPLIED, INCLUDING WITHOUT LIMITATION ANY IMPLIED WARRANTIES OF MERCHANTABILITY, FITNESS FOR A PARTICULAR PURPOSE OR NON-INFRINGEMENT OF THIRD PARTY INTELLECTUAL PROPERTY RIGHTS.

These resources are intended for skilled developers designing with TI products. You are solely responsible for (1) selecting the appropriate TI products for your application, (2) designing, validating and testing your application, and (3) ensuring your application meets applicable standards, and any other safety, security, regulatory or other requirements.

These resources are subject to change without notice. TI grants you permission to use these resources only for development of an application that uses the TI products described in the resource. Other reproduction and display of these resources is prohibited. No license is granted to any other TI intellectual property right or to any third party intellectual property right. TI disclaims responsibility for, and you fully indemnify TI and its representatives against any claims, damages, costs, losses, and liabilities arising out of your use of these resources.

TI's products are provided subject to [TI's Terms of Sale](#), [TI's General Quality Guidelines](#), or other applicable terms available either on ti.com or provided in conjunction with such TI products. TI's provision of these resources does not expand or otherwise alter TI's applicable warranties or warranty disclaimers for TI products. Unless TI explicitly designates a product as custom or customer-specified, TI products are standard, catalog, general purpose devices.

TI objects to and rejects any additional or different terms you may propose.

Copyright © 2026, Texas Instruments Incorporated

Last updated 10/2025