

## MMBZ30VCL Dual Channel ESD Protection

### 1 Features

- Ultra Low I/O capacitance = 4.5pF (typical)
- Low leakage current <25nA
- Unidirectional ESD protection for 2 channels or Bidirectional for 1 channel
- IEC 61000-4-2 ESD protection:
  - ±30kV contact discharge
  - ±30kV air-gap discharge
- Temperature range: –55°C to +150°C
- Leaded packages used for automatic optical inspection (AOI)

### 2 Applications

- General Purpose IO Protection
- **Industrial control networks:**
  - DeviceNet
  - Smart distribution systems
- Audio
- Telecommunications

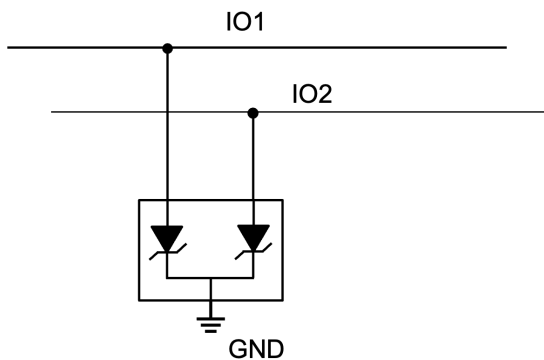

### 3 Description

The MMBZ30VCL is a dual channel unidirectional or single channel bidirectional ESD in a common cathode configuration. The device's low capacitance and low leakage features enable use in high speed applications. The low dynamic resistance allows low clamping voltage to help protect systems against transient events.

The MMBZ30VCL is packaged in the SOT-23, providing two channels of robust transient protection in one space-efficient form factor.

#### Package Information

PART NUMBER	PACKAGE <sup>(1)</sup>	PACKAGE SIZE <sup>(2)</sup>
MMBZ30VCL	DBZ (SOT-23, 3)	2.92mm × 2.37mm

(1) For more information, see [Section 8](#).

(2) The package size (length × width) is a nominal value and includes pins, where applicable.

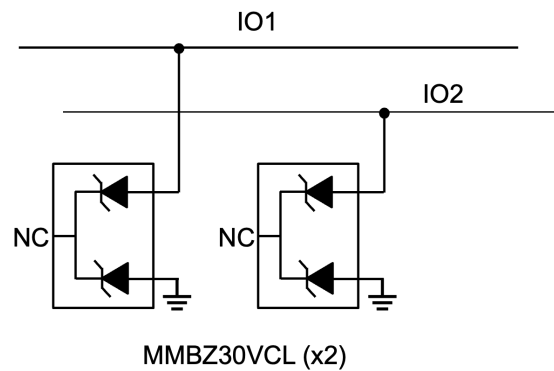

### Typical Application



## Table of Contents

<b>1 Features</b> .....	1	5.7 Typical Characteristics.....	5
<b>2 Applications</b> .....	1	<b>6 Device and Documentation Support</b> .....	6
<b>3 Description</b> .....	1	6.1 Documentation Support.....	6
<b>4 Pin Configuration and Functions</b> .....	3	6.2 Receiving Notification of Documentation Updates.....	6
<b>5 Specifications</b> .....	3	6.3 Support Resources.....	6
5.1 Absolute Maximum Ratings.....	3	6.4 Trademarks.....	6
5.2 ESD Ratings—JEDEC Specification.....	3	6.5 Electrostatic Discharge Caution.....	6
5.3 ESD Ratings—IEC Specification.....	3	6.6 Glossary.....	6
5.4 Recommended Operating Conditions.....	4	<b>7 Revision History</b> .....	6
5.5 Thermal Information.....	4	<b>8 Mechanical, Packaging, and Orderable Information</b> ....	6
5.6 Electrical Characteristics.....	4		

## 4 Pin Configuration and Functions

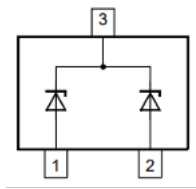

Figure 4-1. DBZ Package, 3-Pin SOT-23 (Top View)

Table 4-1. Pin Functions

PIN		DESCRIPTION
NAME	NO.	
AN1	1	Anode of diode 1
AN2	2	Anode of diode 2
CC	3	Common Cathode

## 5 Specifications

### 5.1 Absolute Maximum Ratings

over operating free-air temperature range (unless otherwise noted)<sup>(1)</sup>

		MIN	MAX	UNIT
P <sub>PP</sub>	IEC 61643-321 Power (t <sub>p</sub> - 10/1000μs) at 25°C		20	W
I <sub>PP</sub>	IEC 61643-321 Current (t <sub>p</sub> - 10/1000μs) at 25°C		0.5	A
T <sub>A</sub>	Operating free-air temperature	-55	150	°C
T <sub>J</sub>	Junction temperature	-55	150	
T <sub>stg</sub>	Storage temperature	-65	155	

- (1) Operation outside the Absolute Maximum Ratings may cause permanent device damage. Absolute Maximum Ratings do not imply functional operation of the device at these or any other conditions beyond those listed under Recommended Operating Conditions. If used outside the Recommended Operating Conditions but within the Absolute Maximum Ratings, the device may not be fully functional, and this may affect device reliability, functionality, performance, and shorten the device lifetime.

### 5.2 ESD Ratings—JEDEC Specification

			VALUE	UNIT
V <sub>(ESD)</sub>	Electrostatic discharge	Human body model (HBM), per ANSI/ESDA/ JEDEC JS-001 <sup>(1)</sup>	± 2500	V
		Charged device model (CDM), per JEDEC specification JS-002 <sup>(2)</sup>	± 1000	

- (1) JEDEC document JEP155 states that 500V HBM allows safe manufacturing with a standard ESD control process.  
 (2) JEDEC document JEP157 states that 250V CDM allows safe manufacturing with a standard ESD control process.

### 5.3 ESD Ratings—IEC Specification

			VALUE	UNIT
V <sub>(ESD)</sub>	Electrostatic discharge	IEC 61000-4-2 Contact Discharge, all pins	±30000	V
		IEC 61000-4-2 Air-gap Discharge, all pins	±30000	

## 5.4 Recommended Operating Conditions

over operating free-air temperature range (unless otherwise noted)

		MIN	NOM	MAX	UNIT
$T_A$	Operating free-air temperature	-55		150	°C

## 5.5 Thermal Information

THERMAL METRIC <sup>(1)</sup>		MMBZ30VCL	UNIT
		DBZ (SOT-23)	
		3 PINS	
$R_{\theta JA}$	Junction-to-ambient thermal resistance	262.6	°C/W
$R_{\theta JC(top)}$	Junction-to-case (top) thermal resistance	147.0	°C/W
$R_{\theta JB}$	Junction-to-board thermal resistance	96.1	°C/W
$\Psi_{JT}$	Junction-to-top characterization parameter	33.5	°C/W
$\Psi_{JB}$	Junction-to-board characterization parameter	95.4	°C/W
$R_{\theta JC(bot)}$	Junction-to-case (bottom) thermal resistance	N/A	°C/W

(1) For more information about traditional and new thermal metrics, see the [Semiconductor and IC Package Thermal Metrics](#) application report.

## 5.6 Electrical Characteristics

over  $T_A = 25^\circ\text{C}$  (unless otherwise noted)

PARAMETER		TEST CONDITIONS	MIN	TYP	MAX	UNIT
$V_F$	Forward Voltage	$I_F = 10\text{mA}$ , $T_A = 25^\circ\text{C}$			1.1	V
$V_{RWM}$	Reverse stand-off voltage	$T_A = 25^\circ\text{C}$			24	V
$V_{BR}$	Breakdown voltage <sup>(1)</sup>	$I_T = 10\text{mA}$ , $T_A = 25^\circ\text{C}$	24.8		34.8	V
$V_{CLAMP}$	Clamping voltage <sup>(2)</sup>	$I_{PPM} = 0.5\text{A}$ , $t_p = 10/1000\mu\text{s}$		31	40	V
$I_{LEAK}$	Leakage current	$V_{IO} = \pm 24\text{V}$		1	25	nA
$S_Z$	Temperature Coefficient	$I_Z = 10\text{mA}$		13		mV/C
$C_L$	Line capacitance	$V_{IO} = 0\text{V}$ , $f = 1\text{MHz}$ , $V_{pp} = 30\text{mV}$		4.5		pF

(1)  $V_{BR}$  is defined as the voltage when 10mA is applied and before the device enters into the shallow snapback state

(2) Device stressed with 10/1000  $\mu\text{s}$  exponential decay waveform according to IEC 61643-321

## 5.7 Typical Characteristics

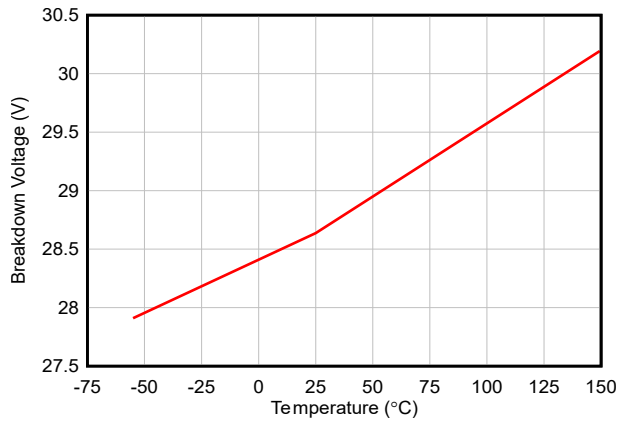

**Figure 5-1. Breakdown Voltage vs Temperature**

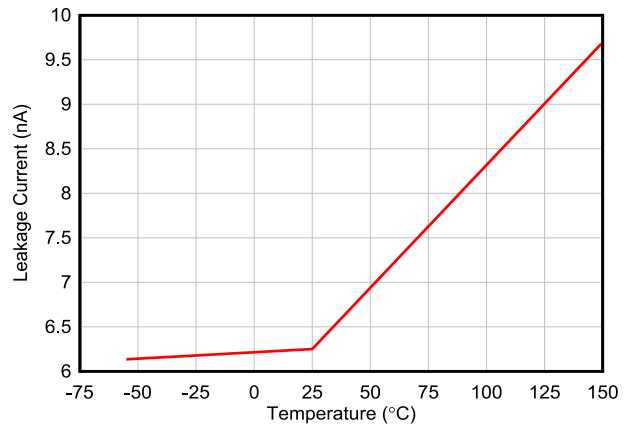

**Figure 5-2. Leakage Current vs Temperature**

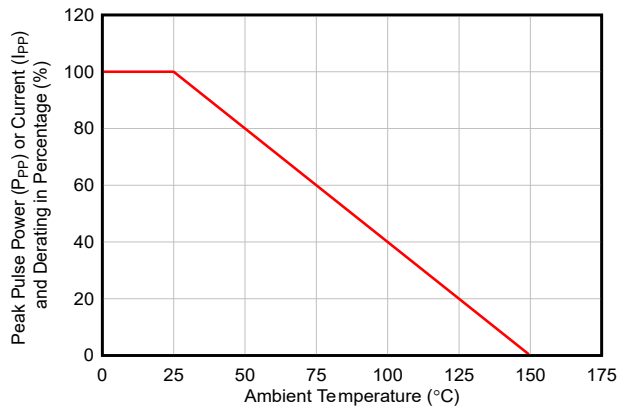

**Figure 5-3. Peak Pulse Power Derating Curve**

## 6 Device and Documentation Support

TI offers an extensive line of development tools. Tools and software to evaluate the performance of the device, generate code, and develop solutions are listed below.

### 6.1 Documentation Support

#### 6.1.1 Related Documentation

For related documentation, see the following:

- Texas Instruments, [ESD Layout Guide application reports](#)
- Texas Instruments, [Generic ESD Evaluation Module user's guide](#)
- Texas Instruments, [Picking ESD Diodes for Ultra High-Speed Data Lines application reports](#)
- Texas Instruments, [Reading and Understanding an ESD Protection data sheet](#)

### 6.2 Receiving Notification of Documentation Updates

To receive notification of documentation updates, navigate to the device product folder on [ti.com](#). Click on *Notifications* to register and receive a weekly digest of any product information that has changed. For change details, review the revision history included in any revised document.

### 6.3 Support Resources

[TI E2E™ support forums](#) are an engineer's go-to source for fast, verified answers and design help — straight from the experts. Search existing answers or ask your own question to get the quick design help you need.

Linked content is provided "AS IS" by the respective contributors. They do not constitute TI specifications and do not necessarily reflect TI's views; see TI's [Terms of Use](#).

### 6.4 Trademarks

TI E2E™ is a trademark of Texas Instruments.

All trademarks are the property of their respective owners.

### 6.5 Electrostatic Discharge Caution



This integrated circuit can be damaged by ESD. Texas Instruments recommends that all integrated circuits be handled with appropriate precautions. Failure to observe proper handling and installation procedures can cause damage.

ESD damage can range from subtle performance degradation to complete device failure. Precision integrated circuits may be more susceptible to damage because very small parametric changes could cause the device not to meet its published specifications.

### 6.6 Glossary

[TI Glossary](#) This glossary lists and explains terms, acronyms, and definitions.

## 7 Revision History

DATE	REVISION	NOTES
November 2024	*	Initial Release

## 8 Mechanical, Packaging, and Orderable Information

The following pages include mechanical, packaging, and orderable information. This information is the most current data available for the designated devices. This data is subject to change without notice and revision of this document. For browser-based versions of this data sheet, refer to the left-hand navigation.

**PACKAGING INFORMATION**

Orderable part number	Status (1)	Material type (2)	Package   Pins	Package qty   Carrier	RoHS (3)	Lead finish/ Ball material (4)	MSL rating/ Peak reflow (5)	Op temp (°C)	Part marking (6)
<a href="#">MMBZ30VCLDBZR</a>	Active	Production	SOT-23 (DBZ)   3	3000   LARGE T&R	Yes	SN	Level-1-260C-UNLIM	-55 to 150	3ICG
MMBZ30VCLDBZR.B	Active	Production	SOT-23 (DBZ)   3	3000   LARGE T&R	Yes	SN	Level-1-260C-UNLIM	-55 to 150	3ICG

(1) **Status:** For more details on status, see our [product life cycle](#).

(2) **Material type:** When designated, preproduction parts are prototypes/experimental devices, and are not yet approved or released for full production. Testing and final process, including without limitation quality assurance, reliability performance testing, and/or process qualification, may not yet be complete, and this item is subject to further changes or possible discontinuation. If available for ordering, purchases will be subject to an additional waiver at checkout, and are intended for early internal evaluation purposes only. These items are sold without warranties of any kind.

(3) **RoHS values:** Yes, No, RoHS Exempt. See the [TI RoHS Statement](#) for additional information and value definition.

(4) **Lead finish/Ball material:** Parts may have multiple material finish options. Finish options are separated by a vertical ruled line. Lead finish/Ball material values may wrap to two lines if the finish value exceeds the maximum column width.

(5) **MSL rating/Peak reflow:** The moisture sensitivity level ratings and peak solder (reflow) temperatures. In the event that a part has multiple moisture sensitivity ratings, only the lowest level per JEDEC standards is shown. Refer to the shipping label for the actual reflow temperature that will be used to mount the part to the printed circuit board.

(6) **Part marking:** There may be an additional marking, which relates to the logo, the lot trace code information, or the environmental category of the part.

Multiple part markings will be inside parentheses. Only one part marking contained in parentheses and separated by a "-" will appear on a part. If a line is indented then it is a continuation of the previous line and the two combined represent the entire part marking for that device.

**Important Information and Disclaimer:**The information provided on this page represents TI's knowledge and belief as of the date that it is provided. TI bases its knowledge and belief on information provided by third parties, and makes no representation or warranty as to the accuracy of such information. Efforts are underway to better integrate information from third parties. TI has taken and continues to take reasonable steps to provide representative and accurate information but may not have conducted destructive testing or chemical analysis on incoming materials and chemicals. TI and TI suppliers consider certain information to be proprietary, and thus CAS numbers and other limited information may not be available for release.

In no event shall TI's liability arising out of such information exceed the total purchase price of the TI part(s) at issue in this document sold by TI to Customer on an annual basis.

**OTHER QUALIFIED VERSIONS OF MMBZ30VCL :**

- Automotive : [MMBZ30VCL-Q1](#)

**NOTE: Qualified Version Definitions:**

- Automotive - Q100 devices qualified for high-reliability automotive applications targeting zero defects



**TAPE AND REEL INFORMATION**

**QUADRANT ASSIGNMENTS FOR PIN 1 ORIENTATION IN TAPE**

\*All dimensions are nominal

Device	Package Type	Package Drawing	Pins	SPQ	Reel Diameter (mm)	Reel Width W1 (mm)	A0 (mm)	B0 (mm)	K0 (mm)	P1 (mm)	W (mm)	Pin1 Quadrant
MMBZ30VCLDBZR	SOT-23	DBZ	3	3000	180.0	8.4	3.2	2.85	1.3	4.0	8.0	Q3

**TAPE AND REEL BOX DIMENSIONS**

\*All dimensions are nominal

Device	Package Type	Package Drawing	Pins	SPQ	Length (mm)	Width (mm)	Height (mm)
MMBZ30VCLDBZR	SOT-23	DBZ	3	3000	210.0	185.0	35.0

# DBZ0003A



## PACKAGE OUTLINE SOT-23 - 1.12 mm max height

SMALL OUTLINE TRANSISTOR

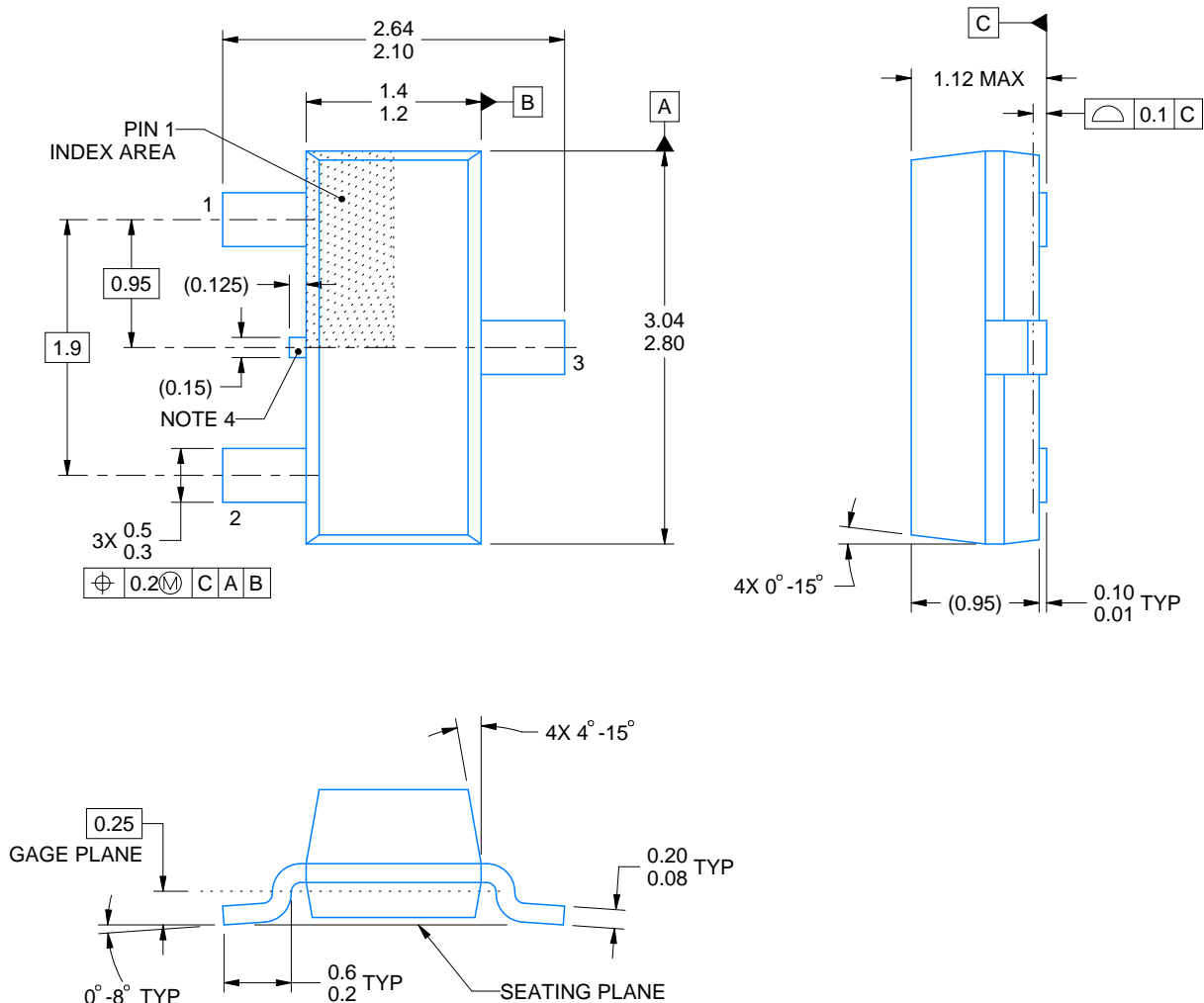

4214838/F 08/2024

### NOTES:

1. All linear dimensions are in millimeters. Any dimensions in parenthesis are for reference only. Dimensioning and tolerancing per ASME Y14.5M.
2. This drawing is subject to change without notice.
3. Reference JEDEC registration TO-236, except minimum foot length.
4. Support pin may differ or may not be present.
5. Body dimensions do not include mold flash, protrusions, or gate burrs. Mold flash, protrusions, or gate burrs shall not exceed 0.25mm per side

# EXAMPLE BOARD LAYOUT

DBZ0003A

SOT-23 - 1.12 mm max height

SMALL OUTLINE TRANSISTOR



LAND PATTERN EXAMPLE  
SCALE:15X



SOLDER MASK DETAILS

4214838/F 08/2024

NOTES: (continued)

5. Publication IPC-7351 may have alternate designs.
6. Solder mask tolerances between and around signal pads can vary based on board fabrication site.

# EXAMPLE STENCIL DESIGN

DBZ0003A

SOT-23 - 1.12 mm max height

SMALL OUTLINE TRANSISTOR



SOLDER PASTE EXAMPLE  
BASED ON 0.125 THICK STENCIL  
SCALE:15X

4214838/F 08/2024

NOTES: (continued)

7. Laser cutting apertures with trapezoidal walls and rounded corners may offer better paste release. IPC-7525 may have alternate design recommendations.
8. Board assembly site may have different recommendations for stencil design.

## IMPORTANT NOTICE AND DISCLAIMER

TI PROVIDES TECHNICAL AND RELIABILITY DATA (INCLUDING DATASHEETS), DESIGN RESOURCES (INCLUDING REFERENCE DESIGNS), APPLICATION OR OTHER DESIGN ADVICE, WEB TOOLS, SAFETY INFORMATION, AND OTHER RESOURCES "AS IS" AND WITH ALL FAULTS, AND DISCLAIMS ALL WARRANTIES, EXPRESS AND IMPLIED, INCLUDING WITHOUT LIMITATION ANY IMPLIED WARRANTIES OF MERCHANTABILITY, FITNESS FOR A PARTICULAR PURPOSE OR NON-INFRINGEMENT OF THIRD PARTY INTELLECTUAL PROPERTY RIGHTS.

These resources are intended for skilled developers designing with TI products. You are solely responsible for (1) selecting the appropriate TI products for your application, (2) designing, validating and testing your application, and (3) ensuring your application meets applicable standards, and any other safety, security, regulatory or other requirements.

These resources are subject to change without notice. TI grants you permission to use these resources only for development of an application that uses the TI products described in the resource. Other reproduction and display of these resources is prohibited. No license is granted to any other TI intellectual property right or to any third party intellectual property right. TI disclaims responsibility for, and you fully indemnify TI and its representatives against any claims, damages, costs, losses, and liabilities arising out of your use of these resources.

TI's products are provided subject to [TI's Terms of Sale](#), [TI's General Quality Guidelines](#), or other applicable terms available either on [ti.com](#) or provided in conjunction with such TI products. TI's provision of these resources does not expand or otherwise alter TI's applicable warranties or warranty disclaimers for TI products. Unless TI explicitly designates a product as custom or customer-specified, TI products are standard, catalog, general purpose devices.

TI objects to and rejects any additional or different terms you may propose.

Copyright © 2025, Texas Instruments Incorporated

Last updated 10/2025