

## TCA9517 Level-Shifting I<sup>2</sup>C Bus Repeater

### 1 Features

- Two-Channel Bidirectional Buffer
- I<sup>2</sup>C Bus and SMBus Compatible
- Operating Supply Voltage Range of 0.9 V to 5.5 V on A-side
- Operating Supply Voltage Range of 2.7 V to 5.5 V on B-side
- Voltage-Level Translation From 0.9 V - 5.5 V to 2.7 V - 5.5 V
- Footprint and Functional Replacement for PCA9515B
- Active-High Repeater-Enable Input
- Open-Drain I<sup>2</sup>C I/O
- 5.5-V Tolerant I<sup>2</sup>C and Enable Input Support Mixed-Mode Signal Operation
- Accommodates Standard Mode and Fast Mode I<sup>2</sup>C Devices and Multiple Masters
- High-Impedance I<sup>2</sup>C Pins When Powered-Off
- Latch-Up Performance Exceeds 100 mA Per JESD 78, Class II
- ESD Protection Exceeds JESD 22
  - 5500 V Human-Body Model (A114-A)
  - 200 V Machine Model (A115-A)
  - 1000 V Charged-Device Model (C101)

### 2 Applications

- Servers
- Routers (Telecom Switching Equipment)
- Industrial Equipment
- Products with Many I<sup>2</sup>C Slaves and/or Long PCB Traces

### 3 Description

The TCA9517 is a bidirectional buffer with level shifting capabilities for I<sup>2</sup>C and SMBus systems. It provides bidirectional voltage-level translation (up-translation/down-translation) between low voltages (down to 0.9 V) and higher voltages (2.7 V to 5.5 V) in mixed-mode applications. This device enables I<sup>2</sup>C and SMBus systems to be extended without degradation of performance, even during level shifting.

The TCA9517 buffers both the serial data (SDA) and the serial clock (SCL) signals on the I<sup>2</sup>C bus, thus allowing two buses of up to 400-pF bus capacitance to be connected in an I<sup>2</sup>C application.

The TCA9517 has two types of drivers: A-side drivers and B-side drivers. All inputs and I/Os are over-voltage tolerant to 5.5 V, even when the device is unpowered ( $V_{CCB}$  and/or  $V_{CCA} = 0$  V).

#### Device Information<sup>(1)</sup>

PART NUMBER	PACKAGE	BODY SIZE (NOM)
TCA9517	VSSOP (8)	3.00 mm x 3.00 mm
	SOIC (8)	4.90 mm x 3.91 mm

(1) For all available packages, see the orderable addendum at the end of the datasheet.

#### Simplified Schematic

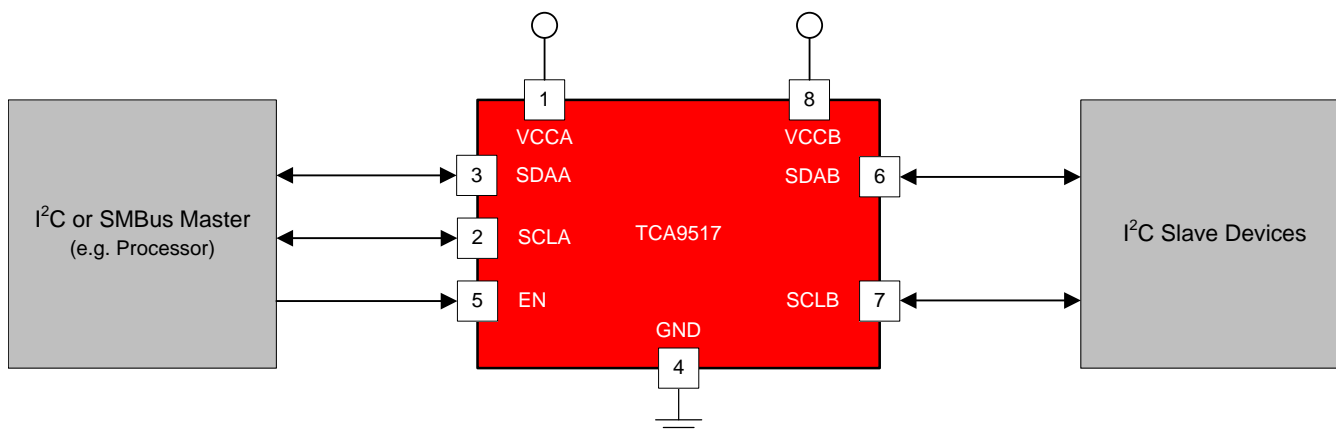

## Table of Contents

<b>1 Features</b> .....	<b>1</b>	9.1 Overview .....	<b>10</b>
<b>2 Applications</b> .....	<b>1</b>	9.2 Functional Block Diagram .....	<b>10</b>
<b>3 Description</b> .....	<b>1</b>	9.3 Feature Description .....	<b>11</b>
<b>4 Revision History</b> .....	<b>2</b>	9.4 Device Functional Modes .....	<b>11</b>
<b>5 Description (continued)</b> .....	<b>3</b>	<b>10 Application and Implementation</b> .....	<b>12</b>
<b>6 Pin Configuration and Functions</b> .....	<b>4</b>	10.1 Application Information .....	<b>12</b>
<b>7 Specifications</b> .....	<b>4</b>	10.2 Typical Application .....	<b>12</b>
7.1 Absolute Maximum Ratings .....	<b>4</b>	<b>11 Power Supply Recommendations</b> .....	<b>15</b>
7.2 ESD Ratings .....	<b>5</b>	<b>12 Layout</b> .....	<b>16</b>
7.3 Recommended Operating Conditions .....	<b>5</b>	12.1 Layout Guidelines .....	<b>16</b>
7.4 Thermal Information .....	<b>5</b>	12.2 Layout Example .....	<b>16</b>
7.5 Electrical Characteristics .....	<b>6</b>	<b>13 Device and Documentation Support</b> .....	<b>17</b>
7.6 Timing Requirements .....	<b>6</b>	13.1 Community Resource .....	<b>17</b>
7.7 I <sup>2</sup> C Interface Switching Characteristics .....	<b>7</b>	13.2 Trademarks .....	<b>17</b>
7.8 Typical Characteristics .....	<b>8</b>	13.3 Electrostatic Discharge Caution .....	<b>17</b>
<b>8 Parameter Measurement Information</b> .....	<b>9</b>	13.4 Glossary .....	<b>17</b>
<b>9 Detailed Description</b> .....	<b>10</b>	<b>14 Mechanical, Packaging, and Orderable Information</b> .....	<b>17</b>

## 4 Revision History

NOTE: Page numbers for previous revisions may differ from page numbers in the current version.

<b>Changes from Revision C (June 2015) to Revision D</b>	<b>Page</b>
• Deleted $V_{CCA} < V_{CCB}$ from the <i>Design Requirements</i> list .....	<b>12</b>

<b>Changes from Revision B (May 2013) to Revision C</b>	<b>Page</b>
• Added <i>Pin Configuration and Functions</i> section, <i>ESD Ratings</i> table, <i>Feature Description</i> section, <i>Device Functional Modes</i> , <i>Application and Implementation</i> section, <i>Power Supply Recommendations</i> section, <i>Layout</i> section, <i>Device and Documentation Support</i> section, and <i>Mechanical, Packaging, and Orderable Information</i> section .....	<b>1</b>
• Removed Ordering Information table .....	<b>3</b>

<b>Changes from Revision A (April 2013) to Revision B</b>	<b>Page</b>
• Updated the TOP-SIDE MARKING column of the ORDERING INFORMATION TABLE .....	<b>1</b>

<b>Changes from Original (December 2012) to Revision A</b>	<b>Page</b>
• Added D package to document .....	<b>1</b>
• Updated the TOP-SIDE MARKING column of the ORDERING INFORMATION TABLE .....	<b>1</b>

## 5 Description (continued)

The type of buffer design on the B-side prevents it from being used in series with devices which use static voltage offset. This is because these devices do not recognize buffered low signals as a valid low and do not propagate it as a buffered low again.

The B-side drivers operate from 2.7 V to 5.5 V. The output low level for this internal buffer is approximately 0.5 V, but the input voltage must be 70 mV or more below the output low level when the output internally is driven low. The higher-voltage low signal is called a buffered low. When the B-side I/O is driven low internally, the low is not recognized as a low by the input. This feature prevents a lockup condition from occurring when the input low condition is released.

The A-side drivers operate from 0.9 V to 5.5 V and drive more current. They do not require the buffered low feature (or the static offset voltage). This means that a low signal on the B-side translates to a nearly 0 V low on the A-side, which accommodates smaller voltage swings of lower-voltage logic. The output pulldown on the A-side drives a hard low, and the input level is set at  $0.3 \times V_{CCA}$  to accommodate the need for a lower low level in systems where the low-voltage-side supply voltage is as low as 0.9 V.

The A-side of two or more TCA9517 s can be connected together, allowing many topographies (See [Figure 8](#) and [Figure 9](#)), with the A-side as the common bus. Also, the A-side can be connected directly to any other buffer with static- or dynamic-offset voltage. Multiple TCA9517 s can be connected in series, A-side to B-side, with no buildup in offset voltage and with only time-of-flight delays to consider. The TCA9517 cannot be connected B-side to B-side, because of the buffered low voltage from the B-side. The B-side cannot be connected to a device with rise time accelerators.

$V_{CCA}$  is only used to provide the  $0.3 \times V_{CCA}$  reference to the A-side input comparators and for the power-good-detect circuit. The TCA9517 logic and all I/Os are powered by the  $V_{CCB}$  pin.

As with the standard I<sup>2</sup>C system, pullup resistors are required to provide the logic-high levels on the buffered bus. The TCA9517 has standard open-drain configuration of the I<sup>2</sup>C bus. The size of these pullup resistors depends on the system, but each side of the repeater must have a pullup resistor. The device is designed to work with Standard mode and Fast mode I<sup>2</sup>C devices in addition to SMBus devices. Standard mode I<sup>2</sup>C devices only specify 3 mA in a generic I<sup>2</sup>C system, where Standard mode devices and multiple masters are possible. Under certain conditions, higher termination currents can be used.

## 6 Pin Configuration and Functions



### Pin Functions

PIN		TYPE	DESCRIPTION
NO.	NAME		
1	VCCA	Supply	A-side supply voltage (0.9 V to 5.5 V)
2	SCLA	Input/Output	Serial clock bus, A-side. Connect to $V_{CCA}$ through a pull-up resistor. If unused, connect directly to ground.
3	SDAA	Input/Output	Serial data bus, A-side. Connect to $V_{CCA}$ through a pull-up resistor. If unused, connect directly to ground.
4	GND	Ground	Ground
5	EN	Input	Active-high repeater enable input
6	SDAB	Input/Output	Serial data bus, B-side. Connect to $V_{CCB}$ through a pull-up resistor. If unused, connect directly to ground.
7	SCLB	Input/Output	Serial clock bus, B-side. Connect to $V_{CCB}$ through a pull-up resistor. If unused, connect directly to ground.
8	VCCB	Supply	B-side and device supply voltage (2.7 V to 5.5 V)

## 7 Specifications

### 7.1 Absolute Maximum Ratings

over operating free-air temperature range (unless otherwise noted)<sup>(1)</sup>

		MIN	MAX	UNIT
$V_{CCB}$	Supply voltage range	-0.5	7	V
$V_{CCA}$	Supply voltage range	-0.5	7	V
$V_I$	Enable input voltage range <sup>(2)</sup>	-0.5	7	V
$V_{I/O}$	I <sup>2</sup> C bus voltage range <sup>(2)</sup>	-0.5	7	V
$I_{IK}$	Input clamp current		-50	mA
$I_{OK}$	Output clamp current		-50	
$I_O$	Continuous output current		±50	mA
	Continuous current through $V_{CC}$ or GND		±100	
$T_{stg}$	Storage temperature range	-65	150	°C

(1) Stresses beyond those listed under *Absolute Maximum Ratings* may cause permanent damage to the device. These are stress ratings only, which do not imply functional operation of the device at these or any other conditions beyond those indicated under *Recommended Operating Conditions*. Exposure to absolute-maximum-rated conditions for extended periods may affect device reliability.

(2) The input negative-voltage and output voltage ratings may be exceeded if the input and output current ratings are observed.

## 7.2 ESD Ratings

		VALUE	UNIT
V <sub>(ESD)</sub>	Electrostatic discharge	Human body model (HBM), per ANSI/ESDA/JEDEC JS-001 <sup>(1)</sup>	±5500
		Charged-device model (CDM), per JEDEC specification JESD22-C101 <sup>(2)</sup>	±1000
		Machine model (A115-A)	±200

(1) JEDEC document JEP155 states that 500 V HBM allows safe manufacturing with a standard ESD control process.

(2) JEDEC document JEP157 states that 250 V CDM allows safe manufacturing with a standard ESD control process.

## 7.3 Recommended Operating Conditions

		MIN	MAX	UNIT
V <sub>CCA</sub>	Supply voltage, A-side bus	0.9 <sup>(1)</sup>	5.5	V
V <sub>CCB</sub>	Supply voltage, B-side bus	2.7	5.5	V
V <sub>IH</sub>	High-level input voltage	SDAA, SCLA	0.7 × V <sub>CCA</sub>	5.5
		SDAB, SCLB	0.7 × V <sub>CCB</sub>	5.5
		EN	0.7 × V <sub>CCB</sub>	5.5
V <sub>IL</sub>	Low-level input voltage	SDAA, SCLA	0.3 × V <sub>CCA</sub>	V
		SDAB, SCLB <sup>(2)</sup>	0.3 × V <sub>CCB</sub>	
		EN	0.3 × V <sub>CCB</sub>	
I <sub>OL</sub>	Low-level output current		6	mA
T <sub>A</sub>	Operating free-air temperature	−40	85	°C

(1) Low-level supply voltage

(2) V<sub>IL</sub> specification is for the first low level seen by the SDAB and SCLB lines. V<sub>ILc</sub> is for the second and subsequent low levels seen by the SDAB and SCLB lines. See [V<sub>ILc</sub> and Pullup Resistor Sizing](#) for V<sub>ILc</sub> application information

## 7.4 Thermal Information

THERMAL METRIC <sup>(1)</sup>	TCA9517		UNIT	
	DGK (VSSOP)	D (SOIC)		
	8 PINS	8 PINS		
R <sub>θJA</sub>	Junction-to-ambient thermal resistance	187.6	133.6	°C/W
R <sub>θJC(top)</sub>	Junction-to-case (top) thermal resistance	59.3	87.6	°C/W
R <sub>θJB</sub>	Junction-to-board thermal resistance	108.6	74.2	°C/W
ψ <sub>JT</sub>	Junction-to-top characterization parameter	3.4	36.9	°C/W
ψ <sub>JB</sub>	Junction-to-board characterization parameter	106.9	73.7	°C/W

(1) For more information about traditional and new thermal metrics, see the *Semiconductor and IC Package Thermal Metrics* application report, [SPRA953](#).

## 7.5 Electrical Characteristics

 $V_{CCB} = 2.7\text{ V to }5.5\text{ V}$ ,  $GND = 0\text{ V}$ ,  $T_A = -40^\circ\text{C to }85^\circ\text{C}$  (unless otherwise noted)

PARAMETER		TEST CONDITIONS	$V_{CCB}$	MIN	TYP	MAX	UNIT
$V_{IK}$	Input clamp voltage	$I_I = -18\text{ mA}$	2.7 V to 5.5 V			-1.2	V
$V_{OL}$	Low-level output voltage	SDAB, SCLB $I_{OL} = 100\ \mu\text{A}$ or $6\text{ mA}$ , $V_{ILA} = V_{ILB} = 0\text{ V}$	2.7 V to 5.5 V	0.45	0.52	0.6	V
		SDAA, SCLA $I_{OL} = 6\text{ mA}$			0.1	0.2	
$V_{OL} - V_{ILC}$	Low-level input voltage below low-level output voltage	SDAB, SCLB ensured by design	2.7 V to 5.5 V		70		mV
$V_{ILC}$	SDA and SCL low-level input voltage contention	SDAB, SCLB	2.7 V to 5.5 V		0.4		V
$I_{CC}$	Quiescent supply current	Both channels low, SDAA = SCLA = GND and SDAB = SCLB = open, or SDAA = SCLA = open and SDAB = SCLB = GND				1	mA
		Both channels high, SDAA = SCLA = $V_{CCA}$ and SDAB = SCLB = $V_{CCB}$ and EN = $V_{CCB}$	5.5 V		1.5	5	
		Both channels low, SDAA = SCLA = GND and SDAB = SCLB = open			1.5	5	
		In contention, SDAA = SCLA = GND and SDAB = SCLB = GND			3	5	
$I_I$	Input leakage current	SDAB, SCLB	2.7 V to 5.5 V	$V_I = V_{CCB}$		$\pm 1$	$\mu\text{A}$
				$V_I = 0.2\text{ V}$		10	
		SDAA, SCLA		$V_I = V_{CCB}$		$\pm 1$	
				$V_I = 0.2\text{ V}$		10	
		EN		$V_I = V_{CCB}$		$\pm 1$	
				$V_I = 0.2\text{ V}$		-10 -30	
$I_{OH}$	High-level output leakage current	SDAB, SCLB	2.7 V to 5.5 V			10	$\mu\text{A}$
		SDAA, SCLA		$V_O = 3.6\text{ V}$			
$C_I$	Input capacitance	EN	$V_I = 3\text{ V}$ or $0\text{ V}$	3.3 V		6 10	pF
		SCLA, SCLB	$V_I = 3\text{ V}$ or $0\text{ V}$	3.3 V		8 13	
				$0\text{ V}$			
$C_{IO}$	Input/output capacitance	SDAA, SDAB	$V_I = 3\text{ V}$ or $0\text{ V}$	3.3 V		8 13	pF
				$0\text{ V}$			

## 7.6 Timing Requirements

over recommended operating free-air temperature range (unless otherwise noted)

		MIN	MAX	UNIT
$t_{su}$	Setup time, EN high before Start condition <sup>(1)</sup>	100		ns
$t_h$	Hold time, EN high after Stop condition <sup>(1)</sup>	100		ns

(1) EN should change state only when the global bus and the repeater port are in an idle state.

## 7.7 I<sup>2</sup>C Interface Switching Characteristics

 $V_{CCB} = 2.7\text{ V to }5.5\text{ V}$ ,  $GND = 0\text{ V}$ ,  $T_A = -40^\circ\text{C to }85^\circ\text{C}$  (unless otherwise noted)<sup>(1)</sup> <sup>(2)</sup>

PARAMETER		FROM (INPUT)	TO (OUTPUT)	TEST CONDITIONS	MIN	TYP <sup>(3)</sup>	MAX	UNIT				
$t_{PLZ}$	Propagation delay	SDAB, SCLB <sup>(4)</sup> (see Figure 6)	SDAA, SCLA <sup>(4)</sup> (see Figure 6)		80	141	250	ns				
		SDAA, SCLA <sup>(5)</sup> (see Figure 5)	SDAB, SCLB <sup>(5)</sup> (see Figure 5)		25	74	110					
$t_{PZL}$	Propagation delay	SDAB, SCLB	SDAA, SCLA	$V_{CCA} \leq 2.7\text{ V}$ (see Figure 4)	30	76 <sup>(6)</sup>	110	ns				
				$V_{CCA} \geq 3\text{ V}$ (see Figure 4)	10	86	230					
		SDAA, SCLA <sup>(5)</sup> (see Figure 5)	SDAB, SCLB <sup>(5)</sup> (see Figure 5)		60	107	230					
$t_{TLH}$	Transition time	B-side to A side	80%	20%	$V_{CCA} \leq 2.7\text{ V}$ (see Figure 5)	10	12	15	ns			
		A side to B-side (see Figure 4)								40	42	45
										110	125	140
$t_{THL}$	Transition time	B-side to A side	80%	20%	$V_{CCA} \leq 2.7\text{ V}$ (see Figure 5)	1	52 <sup>(6)</sup>	105	ns			
		A side to B-side (see Figure 4)								20	67	175
										30	48	90

- (1) Times are specified with loads of 1.35-k $\Omega$  pull-up resistance and 50-pF load capacitance on the B-side and 167- $\Omega$  pull-up and 57-pF load capacitance on the A side. Different load resistance and capacitance alter the RC time constant, thereby changing the propagation delay and transition times.
- (2) pull-up voltages are  $V_{CCA}$  on the A side and  $V_{CCB}$  on the B-side.
- (3) Typical values were measured with  $V_{CCA} = V_{CCB} = 3.3\text{ V}$  at  $T_A = 25^\circ\text{C}$ , unless otherwise noted.
- (4) The  $t_{PLH}$  delay data from B to A side is measured at 0.4 V on the B-side to 0.5  $V_{CCA}$  on the A side when  $V_{CCA}$  is less than 2 V, and 1.5 V on the A side if  $V_{CCA}$  is greater than 2 V.
- (5) The proportional delay data from A to B-side is measured at 0.3  $V_{CCA}$  on the A side to 1.5 V on the B-side.
- (6) Typical value measured with  $V_{CCA} = 2.7\text{ V}$  at  $T_A = 25^\circ\text{C}$

## 7.8 Typical Characteristics

$V_{CCA} = 0.9\text{ V}$ ,  $V_{CCB} = 2.7\text{ V}$

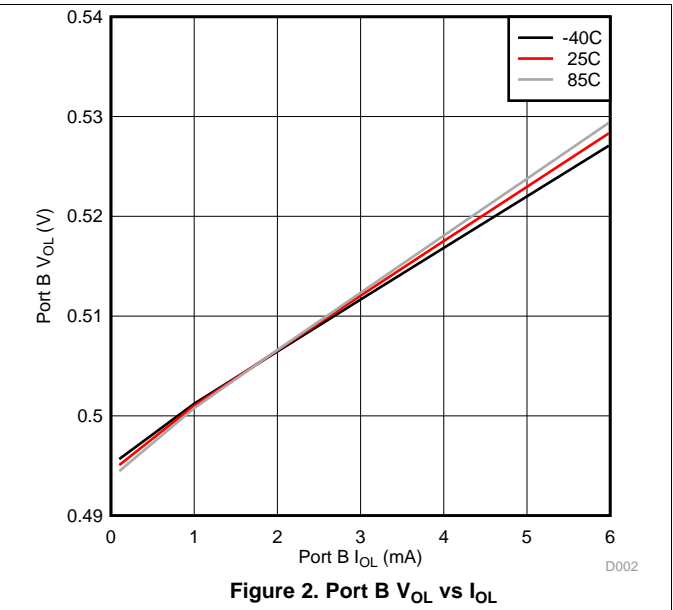
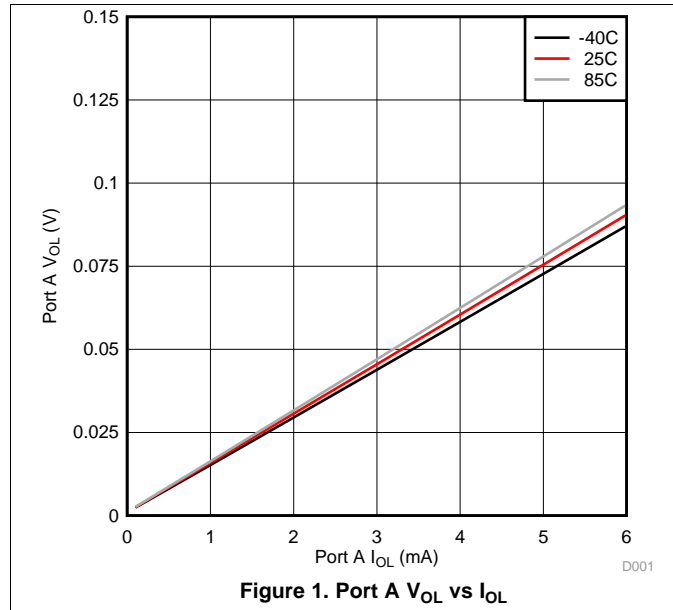

## 8 Parameter Measurement Information

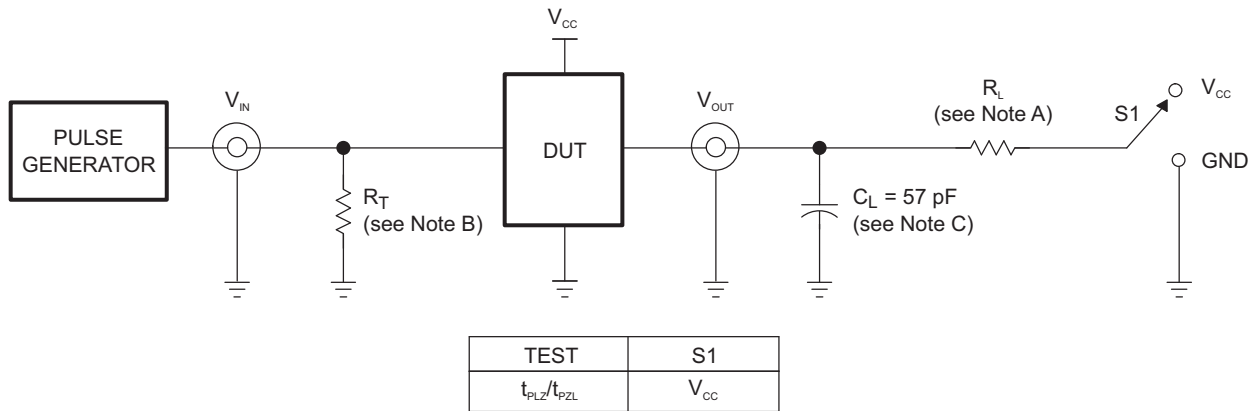

TEST CIRCUIT FOR OPEN-DRAIN OUTPUT

Copyright © 2017, Texas Instruments Incorporated

- A.  $R_L = 167 \Omega$  (0.9 V to 2.7 V) and  $R_L = 450 \Omega$  (3.0 V to 5.5 V) on the A side and 1.35 k $\Omega$  on the B-side
- B.  $R_T$  termination resistance should be equal to  $Z_{OUT}$  of pulse generators.
- C.  $C_L$  includes probe and jig capacitance.
- D. All input pulses are supplied by generators having the following characteristics: PRR  $\leq$  10 MHz,  $Z_O = 50 \Omega$ , slew rate  $\geq$  1 V/ns.
- E. The outputs are measured one at a time, with one transition per measurement.
- F.  $t_{PLH}$  and  $t_{PHL}$  are the same as  $t_{pd}$ .
- G.  $t_{PLZ}$  and  $t_{PHZ}$  are the same as  $t_{dis}$ .
- H.  $t_{PZL}$  and  $t_{PZH}$  are the same as  $t_{en}$ .

Figure 3. Test Circuit

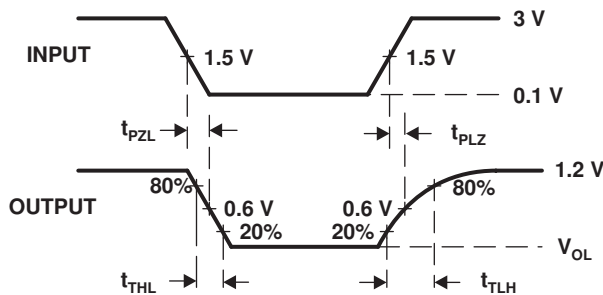

Figure 4. Waveform 1 – Propagation Delay and Transition Times for B-side to A-side

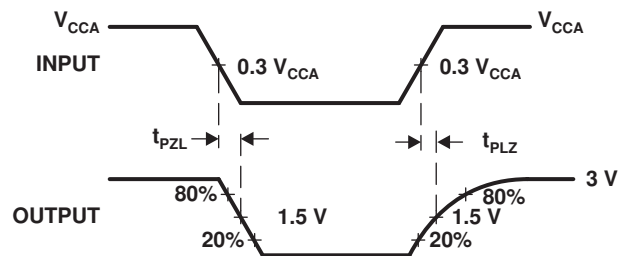

Figure 5. Waveform 2 – Propagation Delay and Transition Times for A-side to B-side

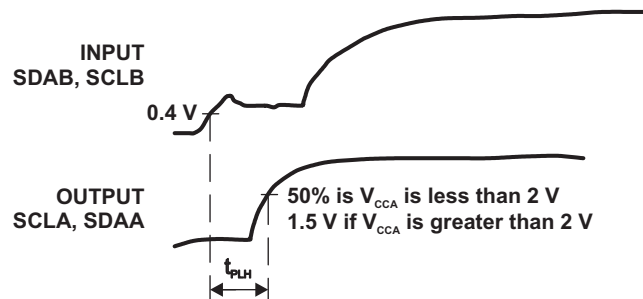

Figure 6. Waveform 3 – Propagation Delay for B-side to A-side

## 9 Detailed Description

### 9.1 Overview

The TCA9517 is a bidirectional buffer with level shifting capabilities for I<sup>2</sup>C and SMBus systems. It provides bidirectional voltage-level translation (up-translation/down-translation) between low voltages (down to 0.9 V) and higher voltages (2.7 V to 5.5 V) in mixed-mode applications. This device enables I<sup>2</sup>C and SMBus systems to be extended without degradation of performance, even during level shifting.

The TCA9517 buffers both the serial data (SDA) and the serial clock (SCL) signals on the I<sup>2</sup>C bus, thus allowing two buses of up to 400-pF bus capacitance to be connected in an I<sup>2</sup>C application.

The TCA9517 has two types of drivers: A-side drivers and B-side drivers. All inputs and I/Os are over-voltage tolerant to 5.5 V, even when the device is unpowered ( $V_{CCB}$  and/or  $V_{CCA} = 0$  V).

### 9.2 Functional Block Diagram

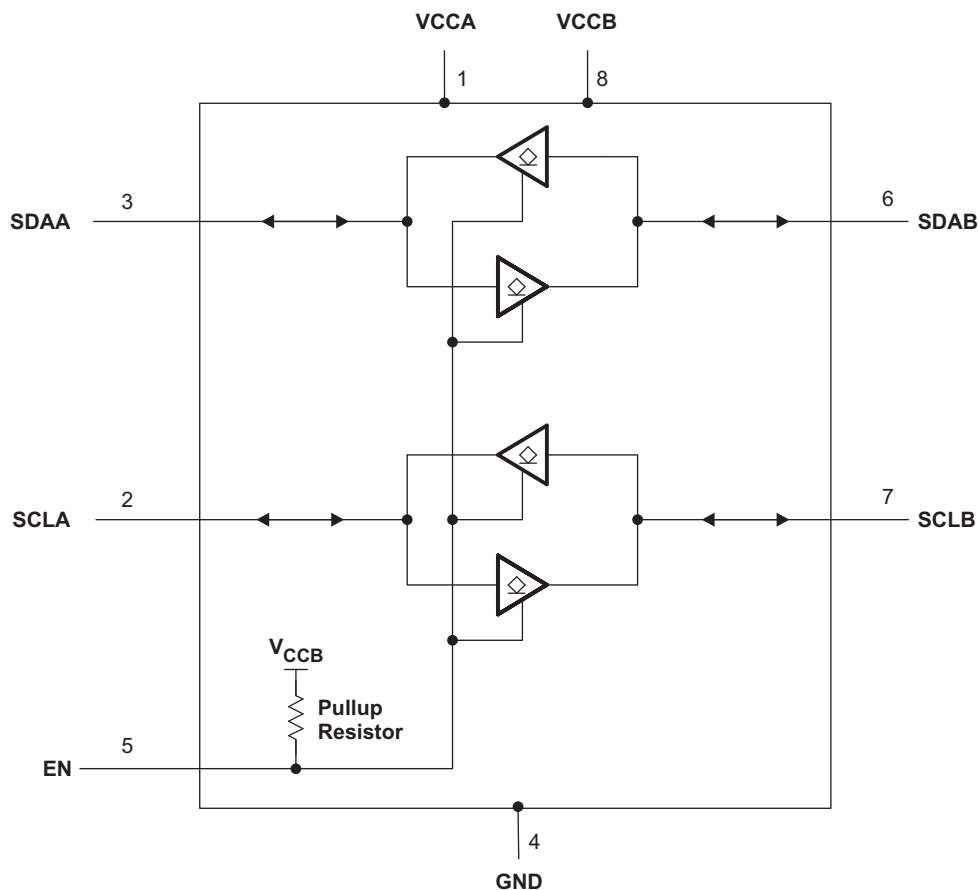

## 9.3 Feature Description

### 9.3.1 Two-Channel Bidirectional Buffer

The TCA9517 is a two-channel bidirectional buffer with level-shifting capabilities

### 9.3.2 Active-High Repeater-Enable Input

The TCA9517 has an active-high enable (EN) input with an internal pull-up to  $V_{CCB}$ , which allows the user to select when the repeater is active. This can be used to isolate a badly behaved slave on power-up reset. The EN input should change state only when the global bus and repeater port are in an idle state, to prevent system failures.

### 9.3.3 $V_{OL}$ B-Side Offset Voltage

The B-side drivers operate from 2.7 V to 5.5 V. The output low level for this internal buffer is approximately 0.5 V, but the input voltage must be 70 mV or more below the output low level when the output internally is driven low. The higher-voltage low signal is called a buffered low. When the B-side I/O is driven low internally, the low is not recognized as a low by the input. This feature prevents a lockup condition from occurring when the input low condition is released. This type of design prevents 2 B-side ports from being connected to each other.

### 9.3.4 Standard Mode and Fast Mode Support

The TCA9517 supports standard mode as well as fast mode I<sup>2</sup>C. The maximum system operating frequency will depend on system design and the delays added by the repeater.

### 9.3.5 Clock Stretching Support

The TCA9517 can support clock stretching, but care needs to be taken to minimize the overshoot voltage presented during the hand-off between the slave and master. This is best done by increasing the pull-up resistor value.

## 9.4 Device Functional Modes

**Table 1. Function Table**

INPUT EN	FUNCTION
L	Outputs disabled
H	SDAA = SDAB SCLA = SCLB

## 10 Application and Implementation

### NOTE

Information in the following applications sections is not part of the TI component specification, and TI does not warrant its accuracy or completeness. TI's customers are responsible for determining suitability of components for their purposes. Customers should validate and test their design implementation to confirm system functionality.

### 10.1 Application Information

A typical application is shown in [Figure 7](#). In this example, the system master is running on a 3.3 V I<sup>2</sup>C bus, and the slave is connected to a 1.2 V I<sup>2</sup>C bus. Both buses run at 400 kHz. Master devices can be placed on either bus.

The TCA9517 is 5-V tolerant, so it does not require any additional circuitry to translate between 0.9 V to 5.5 V bus voltages and 2.7 V to 5.5 V bus voltages.

When the A side of the TCA9517 is pulled low by a driver on the I<sup>2</sup>C bus, a comparator detects the falling edge when it goes below  $0.3 \times V_{CCA}$  and causes the internal driver on the B-side to turn on, causing the B-side to pull down to about 0.5 V. When the B-side of the TCA9517 falls, first a CMOS hysteresis-type input detects the falling edge and causes the internal driver on the A side to turn on and pull the A-side pin down to ground. In order to illustrate what would be seen in a typical application, refer to [Figure 9](#) and [Figure 10](#). If the bus master in [Figure 7](#) were to write to the slave through the TCA9517, waveforms shown in [Figure 9](#) would be observed on the A bus. This looks like a normal I<sup>2</sup>C transmission, except that the high level may be as low as 0.9 V, and the turn on and turn off of the acknowledge signals are slightly delayed.

On the B-side bus of the TCA9517, the clock and data lines would have a positive offset from ground equal to the  $V_{OL}$  of the TCA9517. After the eighth clock pulse, the data line is pulled to the  $V_{OL}$  of the slave device, which is very close to ground in this example. At the end of the acknowledge, the level rises only to the low level set by the driver in the TCA9517 for a short delay, while the A-bus side rises above  $0.3 \times V_{CCA}$  and then continues high.

### 10.2 Typical Application

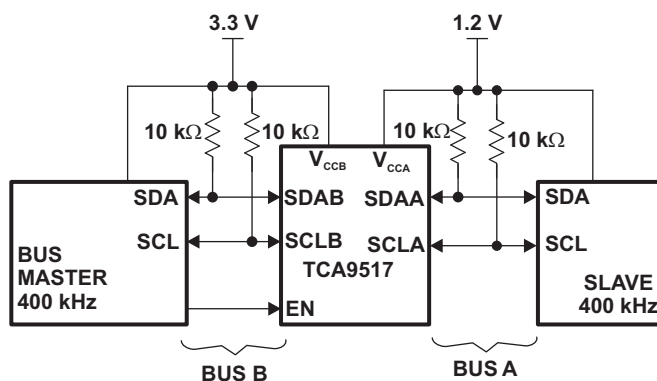

**Figure 7. Typical Application Schematic**

#### 10.2.1 Design Requirements

For the level translating application, the following should be true:

- $V_{CCA}$  = 0.9 V to 5.5 V
- $V_{CCB}$  = 2.7 to 5.5 V
- B-side ports must not be connected together

## Typical Application (continued)

### 10.2.2 Detailed Design Procedure

#### 10.2.2.1 Clock Stretching Support

The TCA9517 can support clock stretching, but care needs to be taken to minimize the overshoot voltage presented during the hand-off between the slave and master. This is best done by increasing the pull-up resistor value.

#### 10.2.2.2 $V_{ILC}$ and Pullup Resistor Sizing

For the TCA9517 to function correctly, all devices on the B-side must be able to pull the B-side below the voltage input low contention level ( $V_{ILC}$ ). This means that the  $V_{OL}$  of any device on the B-side must be below 0.4 V.

$V_{OL}$  of a device can be adjusted by changing the  $I_{OL}$  through the device which is set by the pull-up resistance value. The pull-up resistance on the B-side must be carefully selected to ensure that logic levels will be transferred correctly to the A-side.

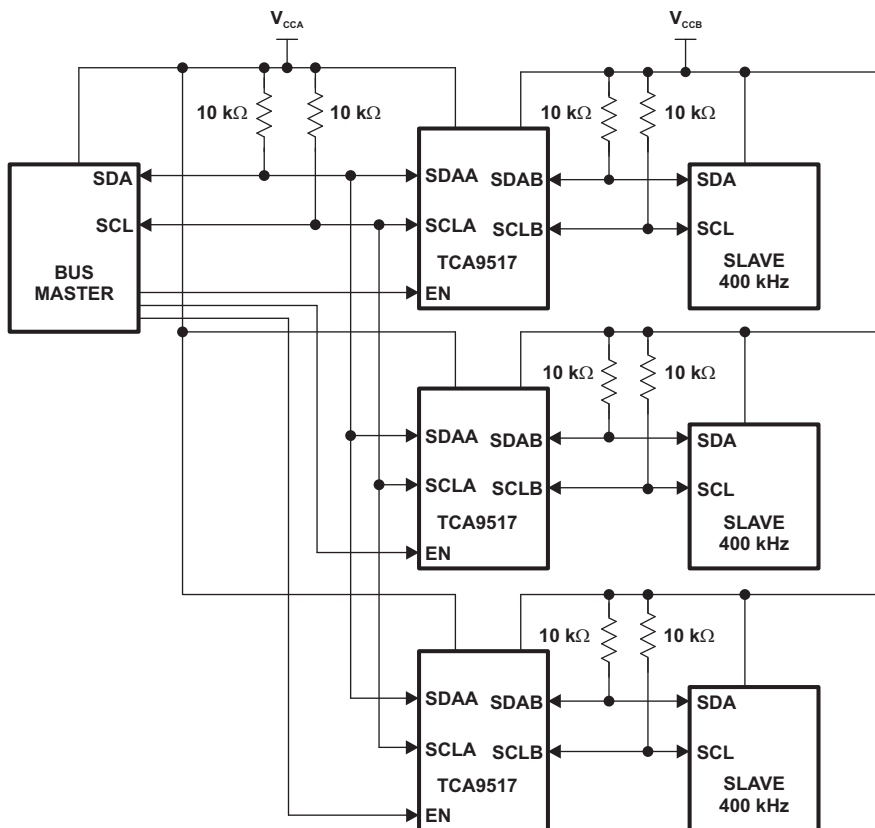

Figure 8. Typical Star Application

Multiple A sides of TCA9517 s can be connected in a star configuration, allowing all nodes to communicate with each other.

Typical Application (continued)

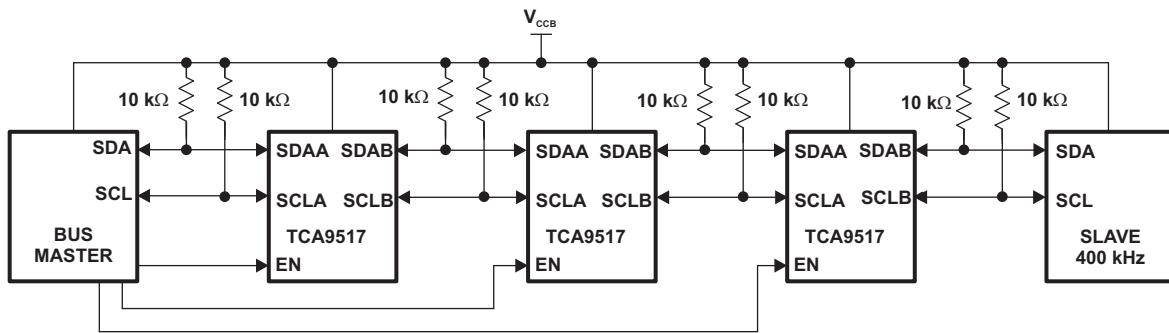

Figure 9. Typical Series Application

To further extend the I<sup>2</sup>C bus for long traces/cables, multiple TCA9517 s can be connected in series as long as the A-side is connected to the B-side. I<sup>2</sup>C bus slave devices can be connected to any of the bus segments. The number of devices that can be connected in series is limited by repeater delay/time-of-flight considerations on the maximum bus speed requirements.

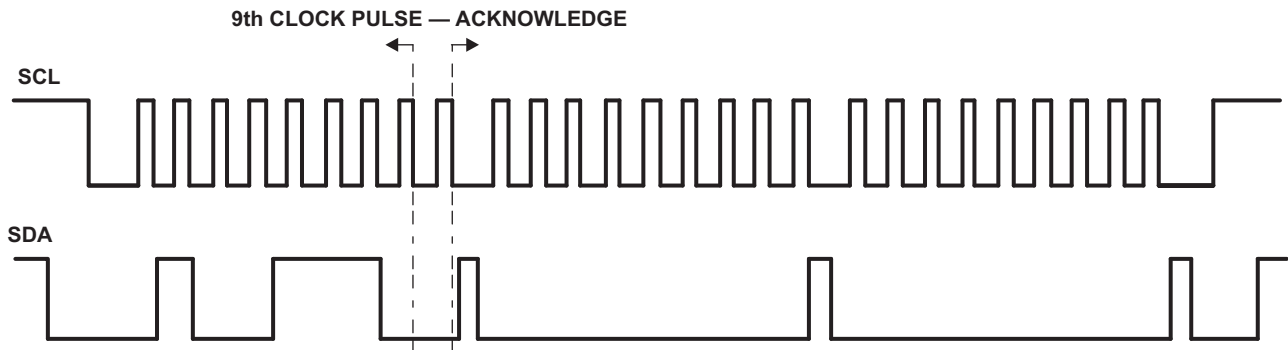

Figure 10. Bus A (0.9 V to 5.5 V Bus) Waveform

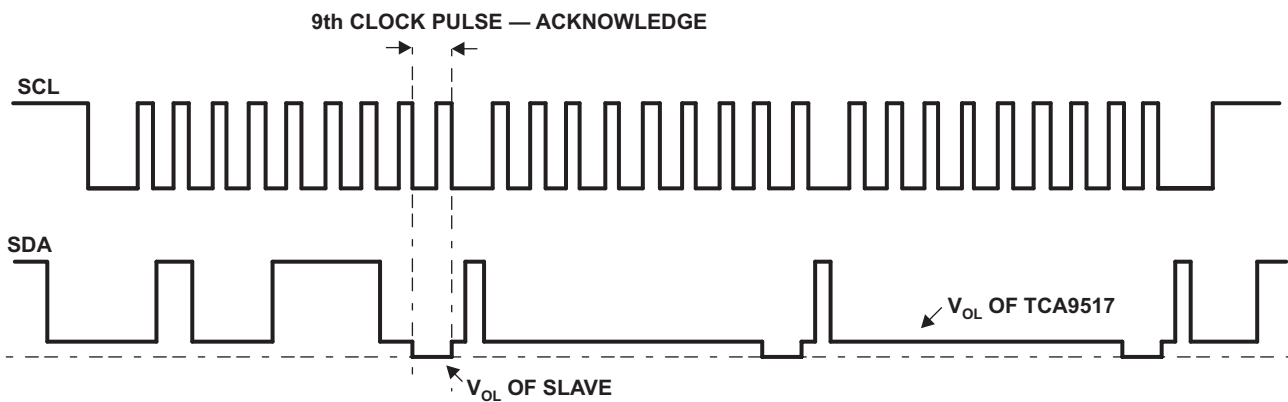
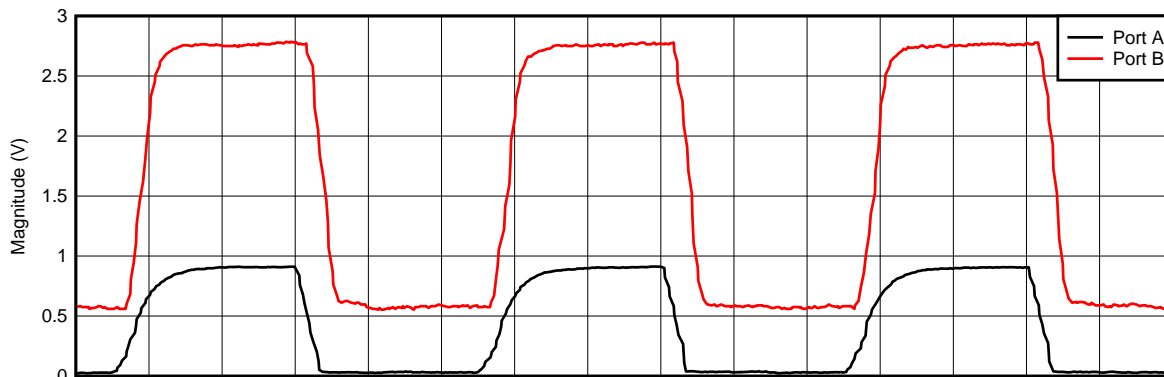

Figure 11. Bus B (2.7 V to 5.5 V Bus) Waveform

## Typical Application (continued)

### 10.2.3 Application Curve



D003

Figure 12. Voltage Translation at 400 kHz,  $V_{CCA} = 0.9\text{ V}$ ,  $V_{CCB} = 2.7\text{ V}$

## 11 Power Supply Recommendations

$V_{CCB}$  and  $V_{CCA}$  can be applied in any sequence at power up. The TCA9517 includes a power-up circuit that keeps the output drivers turned off until  $V_{CCB}$  is above 2.5 V and the  $V_{CCA}$  is above 0.8 V. After power up and with the EN high, a low level on the A-side (below  $0.3 \times V_{CCA}$ ) turns the corresponding B-side driver (either SDA or SCL) on and drives the B-side down to approximately 0.5 V. When the A-side rises above  $0.3 \times V_{CCA}$ , the B-side pull-down driver is turned off and the external pull-up resistor pulls the pin high. When the B-side falls first and goes below  $0.3 \times V_{CCB}$ , the A-side driver is turned on and the A-side pulls down to 0 V. The B-side pull-down is not enabled unless the B-side voltage goes below 0.4 V. If the B-side low voltage does not go below 0.5 V, the A-side driver turns off when the B-side voltage is above  $0.7 \times V_{CCB}$ . If the B-side low voltage goes below 0.4 V, the B-side pull-down driver is enabled, and the B-side is able to rise to only 0.5 V until the A-side rises above  $0.3 \times V_{CCA}$ .

TI recommends using a decoupling capacitor and placing it close to the  $V_{CCA}$  and  $V_{CCB}$  pins of a value of about 100 nF.

## 12 Layout

### 12.1 Layout Guidelines

There are no special layout procedures required for the TCA9517 .

It is recommended that the decoupling capacitors be placed as close to the VCC pins as possible.

### 12.2 Layout Example

Figure 13 shows an example layout of the DGK package.

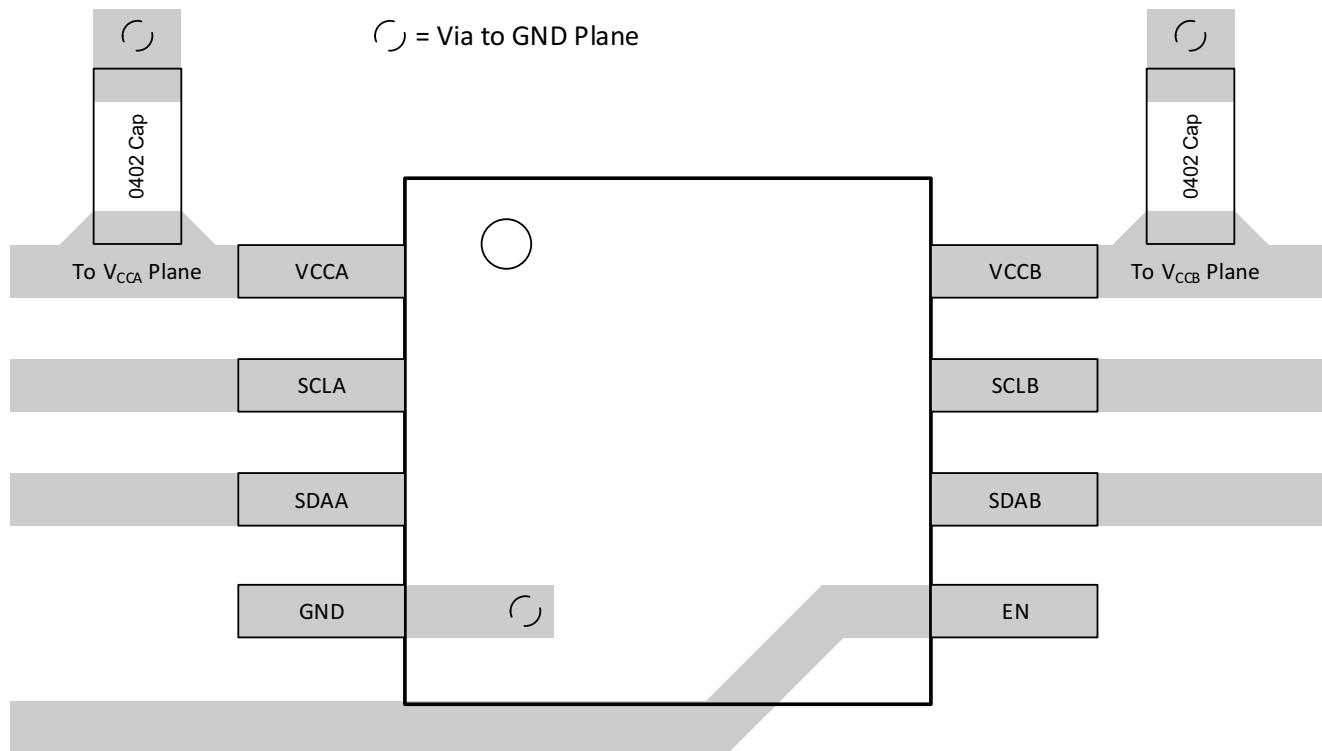

**Figure 13. TCA9517A Layout Example**

## 13 Device and Documentation Support

### 13.1 Community Resource

The following links connect to TI community resources. Linked contents are provided "AS IS" by the respective contributors. They do not constitute TI specifications and do not necessarily reflect TI's views; see TI's [Terms of Use](#).

**TI E2E™ Online Community** *TI's Engineer-to-Engineer (E2E) Community*. Created to foster collaboration among engineers. At [e2e.ti.com](http://e2e.ti.com), you can ask questions, share knowledge, explore ideas and help solve problems with fellow engineers.

**Design Support** *TI's Design Support* Quickly find helpful E2E forums along with design support tools and contact information for technical support.

### 13.2 Trademarks

E2E is a trademark of Texas Instruments.  
All other trademarks are the property of their respective owners.

### 13.3 Electrostatic Discharge Caution



These devices have limited built-in ESD protection. The leads should be shorted together or the device placed in conductive foam during storage or handling to prevent electrostatic damage to the MOS gates.

### 13.4 Glossary

[SLYZ022](#) — *TI Glossary*.

This glossary lists and explains terms, acronyms, and definitions.

## 14 Mechanical, Packaging, and Orderable Information

The following pages include mechanical, packaging, and orderable information. This information is the most current data available for the designated devices. This data is subject to change without notice and revision of this document. For browser-based versions of this data sheet, refer to the left-hand navigation.

**PACKAGING INFORMATION**

Orderable part number	Status (1)	Material type (2)	Package   Pins	Package qty   Carrier	RoHS (3)	Lead finish/ Ball material (4)	MSL rating/ Peak reflow (5)	Op temp (°C)	Part marking (6)
<a href="#">TCA9517DGKR</a>	Active	Production	VSSOP (DGK)   8	2500   LARGE T&R	Yes	NIPDAU   SN   NIPDAUAG	Level-1-260C-UNLIM	-40 to 85	AYK
TCA9517DGKR.B	Active	Production	VSSOP (DGK)   8	2500   LARGE T&R	Yes	NIPDAU	Level-1-260C-UNLIM	-40 to 85	AYK
<a href="#">TCA9517DR</a>	Active	Production	SOIC (D)   8	2500   LARGE T&R	Yes	NIPDAU	Level-1-260C-UNLIM	-40 to 85	PW517
TCA9517DR.B	Active	Production	SOIC (D)   8	2500   LARGE T&R	Yes	NIPDAU	Level-1-260C-UNLIM	-40 to 85	PW517
TCA9517DRG4	Active	Production	SOIC (D)   8	2500   LARGE T&R	Yes	NIPDAU	Level-1-260C-UNLIM	-40 to 85	PW517
TCA9517DRG4.B	Active	Production	SOIC (D)   8	2500   LARGE T&R	Yes	NIPDAU	Level-1-260C-UNLIM	-40 to 85	PW517

(1) **Status:** For more details on status, see our [product life cycle](#).

(2) **Material type:** When designated, preproduction parts are prototypes/experimental devices, and are not yet approved or released for full production. Testing and final process, including without limitation quality assurance, reliability performance testing, and/or process qualification, may not yet be complete, and this item is subject to further changes or possible discontinuation. If available for ordering, purchases will be subject to an additional waiver at checkout, and are intended for early internal evaluation purposes only. These items are sold without warranties of any kind.

(3) **RoHS values:** Yes, No, RoHS Exempt. See the [TI RoHS Statement](#) for additional information and value definition.

(4) **Lead finish/Ball material:** Parts may have multiple material finish options. Finish options are separated by a vertical ruled line. Lead finish/Ball material values may wrap to two lines if the finish value exceeds the maximum column width.

(5) **MSL rating/Peak reflow:** The moisture sensitivity level ratings and peak solder (reflow) temperatures. In the event that a part has multiple moisture sensitivity ratings, only the lowest level per JEDEC standards is shown. Refer to the shipping label for the actual reflow temperature that will be used to mount the part to the printed circuit board.

(6) **Part marking:** There may be an additional marking, which relates to the logo, the lot trace code information, or the environmental category of the part.

Multiple part markings will be inside parentheses. Only one part marking contained in parentheses and separated by a "-" will appear on a part. If a line is indented then it is a continuation of the previous line and the two combined represent the entire part marking for that device.

**Important Information and Disclaimer:**The information provided on this page represents TI's knowledge and belief as of the date that it is provided. TI bases its knowledge and belief on information provided by third parties, and makes no representation or warranty as to the accuracy of such information. Efforts are underway to better integrate information from third parties. TI has taken and continues to take reasonable steps to provide representative and accurate information but may not have conducted destructive testing or chemical analysis on incoming materials and chemicals. TI and TI suppliers consider certain information to be proprietary, and thus CAS numbers and other limited information may not be available for release.

In no event shall TI's liability arising out of such information exceed the total purchase price of the TI part(s) at issue in this document sold by TI to Customer on an annual basis.

**OTHER QUALIFIED VERSIONS OF TCA9517 :**

- Automotive : [TCA9517-Q1](#)

## NOTE: Qualified Version Definitions:

- Automotive - Q100 devices qualified for high-reliability automotive applications targeting zero defects

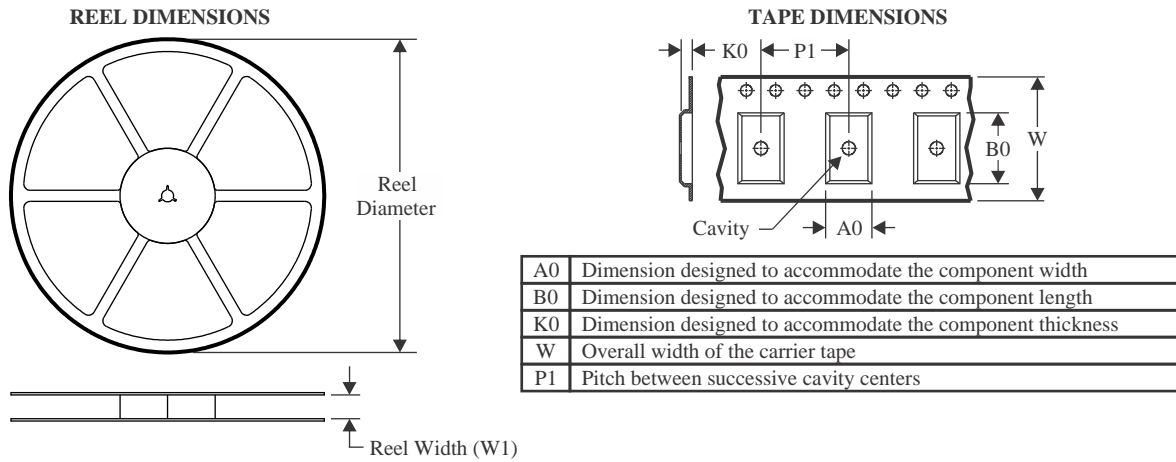
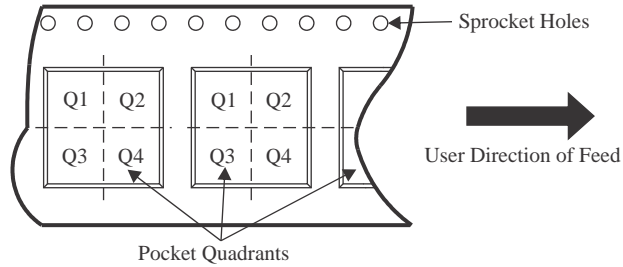
**TAPE AND REEL INFORMATION**

**QUADRANT ASSIGNMENTS FOR PIN 1 ORIENTATION IN TAPE**

\*All dimensions are nominal

Device	Package Type	Package Drawing	Pins	SPQ	Reel Diameter (mm)	Reel Width W1 (mm)	A0 (mm)	B0 (mm)	K0 (mm)	P1 (mm)	W (mm)	Pin1 Quadrant
TCA9517DGKR	VSSOP	DGK	8	2500	330.0	12.4	5.3	3.4	1.4	8.0	12.0	Q1
TCA9517DR	SOIC	D	8	2500	330.0	12.4	6.4	5.2	2.1	8.0	12.0	Q1
TCA9517DRG4	SOIC	D	8	2500	330.0	12.4	6.4	5.2	2.1	8.0	12.0	Q1

**TAPE AND REEL BOX DIMENSIONS**

\*All dimensions are nominal

Device	Package Type	Package Drawing	Pins	SPQ	Length (mm)	Width (mm)	Height (mm)
TCA9517DGKR	VSSOP	DGK	8	2500	353.0	353.0	32.0
TCA9517DR	SOIC	D	8	2500	340.5	336.1	25.0
TCA9517DRG4	SOIC	D	8	2500	340.5	336.1	25.0



D0008A

# PACKAGE OUTLINE

SOIC - 1.75 mm max height

SMALL OUTLINE INTEGRATED CIRCUIT



NOTES:

1. Linear dimensions are in inches [millimeters]. Dimensions in parenthesis are for reference only. Controlling dimensions are in inches. Dimensioning and tolerancing per ASME Y14.5M.
2. This drawing is subject to change without notice.
3. This dimension does not include mold flash, protrusions, or gate burrs. Mold flash, protrusions, or gate burrs shall not exceed  $.006$  [0.15] per side.
4. This dimension does not include interlead flash.
5. Reference JEDEC registration MS-012, variation AA.

# EXAMPLE BOARD LAYOUT

D0008A

SOIC - 1.75 mm max height

SMALL OUTLINE INTEGRATED CIRCUIT



LAND PATTERN EXAMPLE  
EXPOSED METAL SHOWN  
SCALE:8X



SOLDER MASK DETAILS

4214825/C 02/2019

NOTES: (continued)

- 6. Publication IPC-7351 may have alternate designs.
- 7. Solder mask tolerances between and around signal pads can vary based on board fabrication site.

# EXAMPLE STENCIL DESIGN

D0008A

SOIC - 1.75 mm max height

SMALL OUTLINE INTEGRATED CIRCUIT



SOLDER PASTE EXAMPLE  
BASED ON .005 INCH [0.125 MM] THICK STENCIL  
SCALE:8X

4214825/C 02/2019

NOTES: (continued)

8. Laser cutting apertures with trapezoidal walls and rounded corners may offer better paste release. IPC-7525 may have alternate design recommendations.
9. Board assembly site may have different recommendations for stencil design.

# DGK0008A



# PACKAGE OUTLINE

## VSSOP - 1.1 mm max height

SMALL OUTLINE PACKAGE

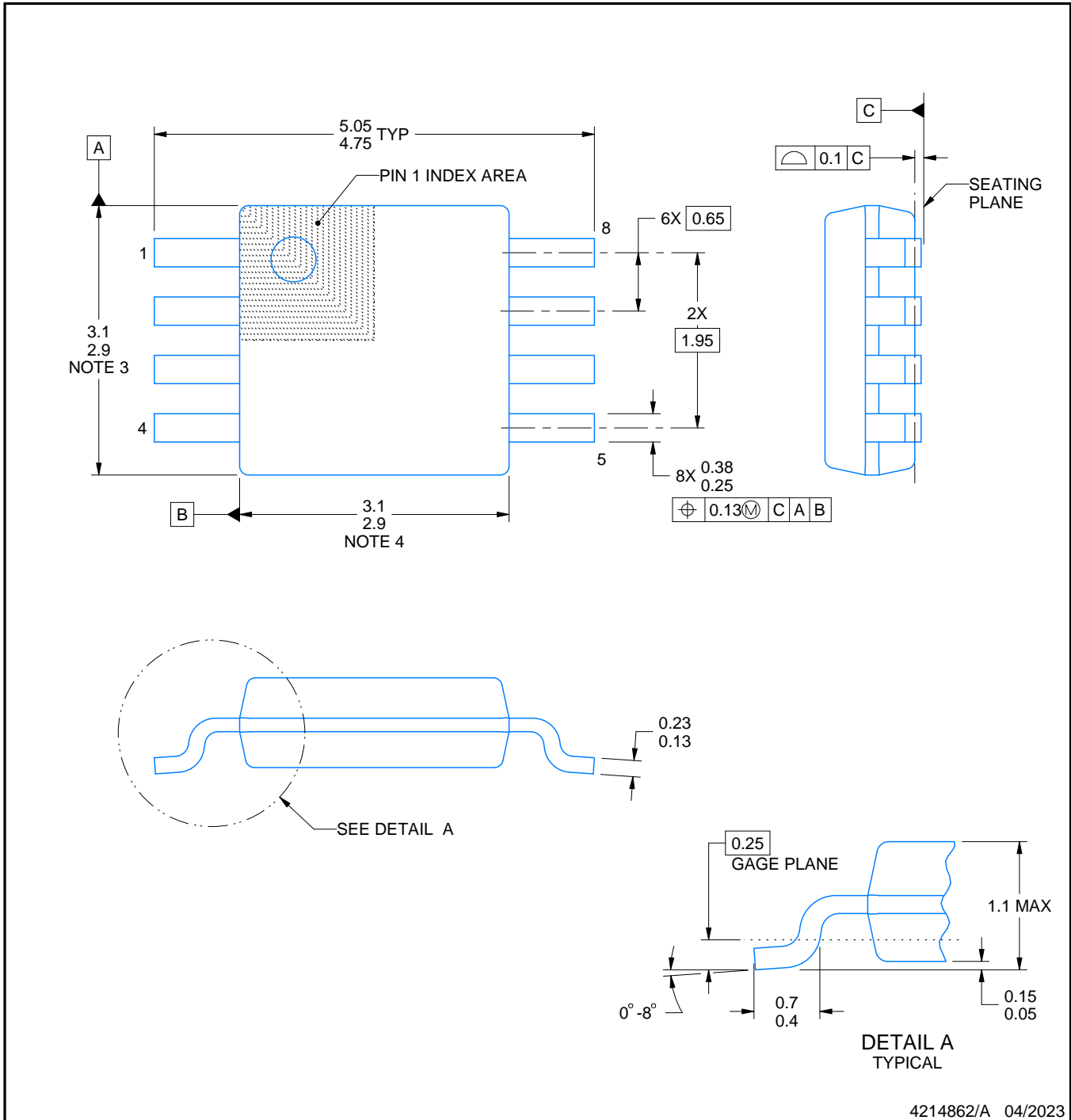

4214862/A 04/2023

**NOTES:**

PowerPAD is a trademark of Texas Instruments.

1. All linear dimensions are in millimeters. Any dimensions in parenthesis are for reference only. Dimensioning and tolerancing per ASME Y14.5M.
2. This drawing is subject to change without notice.
3. This dimension does not include mold flash, protrusions, or gate burrs. Mold flash, protrusions, or gate burrs shall not exceed 0.15 mm per side.
4. This dimension does not include interlead flash. Interlead flash shall not exceed 0.25 mm per side.
5. Reference JEDEC registration MO-187.

# EXAMPLE BOARD LAYOUT

DGK0008A

™ VSSOP - 1.1 mm max height

SMALL OUTLINE PACKAGE



LAND PATTERN EXAMPLE  
EXPOSED METAL SHOWN  
SCALE: 15X



SOLDER MASK DETAILS

4214862/A 04/2023

NOTES: (continued)

6. Publication IPC-7351 may have alternate designs.
7. Solder mask tolerances between and around signal pads can vary based on board fabrication site.
8. Vias are optional depending on application, refer to device data sheet. If any vias are implemented, refer to their locations shown on this view. It is recommended that vias under paste be filled, plugged or tented.
9. Size of metal pad may vary due to creepage requirement.

# EXAMPLE STENCIL DESIGN

DGK0008A

™ VSSOP - 1.1 mm max height

SMALL OUTLINE PACKAGE

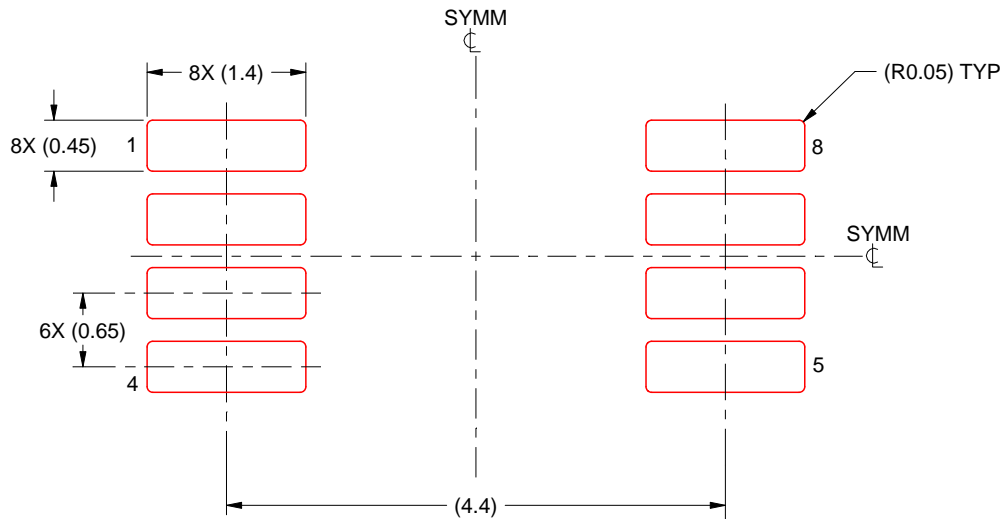

SOLDER PASTE EXAMPLE  
SCALE: 15X

4214862/A 04/2023

NOTES: (continued)

11. Laser cutting apertures with trapezoidal walls and rounded corners may offer better paste release. IPC-7525 may have alternate design recommendations.
12. Board assembly site may have different recommendations for stencil design.

## IMPORTANT NOTICE AND DISCLAIMER

TI PROVIDES TECHNICAL AND RELIABILITY DATA (INCLUDING DATASHEETS), DESIGN RESOURCES (INCLUDING REFERENCE DESIGNS), APPLICATION OR OTHER DESIGN ADVICE, WEB TOOLS, SAFETY INFORMATION, AND OTHER RESOURCES "AS IS" AND WITH ALL FAULTS, AND DISCLAIMS ALL WARRANTIES, EXPRESS AND IMPLIED, INCLUDING WITHOUT LIMITATION ANY IMPLIED WARRANTIES OF MERCHANTABILITY, FITNESS FOR A PARTICULAR PURPOSE OR NON-INFRINGEMENT OF THIRD PARTY INTELLECTUAL PROPERTY RIGHTS.

These resources are intended for skilled developers designing with TI products. You are solely responsible for (1) selecting the appropriate TI products for your application, (2) designing, validating and testing your application, and (3) ensuring your application meets applicable standards, and any other safety, security, regulatory or other requirements.

These resources are subject to change without notice. TI grants you permission to use these resources only for development of an application that uses the TI products described in the resource. Other reproduction and display of these resources is prohibited. No license is granted to any other TI intellectual property right or to any third party intellectual property right. TI disclaims responsibility for, and you fully indemnify TI and its representatives against any claims, damages, costs, losses, and liabilities arising out of your use of these resources.

TI's products are provided subject to [TI's Terms of Sale](#), [TI's General Quality Guidelines](#), or other applicable terms available either on [ti.com](http://ti.com) or provided in conjunction with such TI products. TI's provision of these resources does not expand or otherwise alter TI's applicable warranties or warranty disclaimers for TI products. Unless TI explicitly designates a product as custom or customer-specified, TI products are standard, catalog, general purpose devices.

TI objects to and rejects any additional or different terms you may propose.

Copyright © 2026, Texas Instruments Incorporated

Last updated 10/2025