

TMUXL27518 6-Channel (qSPI, eSPI), 1:2 Multiplexer and Demultiplexer with 1.2V Logic Compatible Control Inputs and Powered off Protection

1 Features

- 1.08V to 1.95V single-supply operation
- Isolation in power-down mode, $V_{CC} = 0$
- Low-capacitance switches, 12pF
- Bandwidth more than 500MHz
- Extended 1.2V logic compatible control inputs across supply
- 3.6V tolerant control inputs
- Powered-off Protection upto 3.6V Signals when $V_{CC}=0$
- Bidirectional Signal Path
- -40°C to $+125^{\circ}\text{C}$ operating temperature

2 Applications

- qSPI , eSPI , SPI Muxing
- Flash Memory Sharing
- SD-SDIO and MMC two-port MUX
- PC VGA video MUX-video systems
- Audio and video signal routing
- Data Centers
- Hardware AI Accelerators
- PC & Notebooks

3 Description

The TMUXL27518 is a bidirectional, 6-channel, 1:2 multiplexer-demultiplexer designed to operate from 1.08V to 1.95V. This device can handle both digital and analog signals, and can transmit signals up to V_{CC} in either direction. The TMUXL27518 has

two control pins, each controlling three 1:2 muxes at the same time, and an enable pin that put all outputs in high-impedance mode. The control pins are compatible with 1.2V logic thresholds across supply voltage range of the device eliminating the need of external logic translation.

Powered-off Protection up to 1.95V on the signal path of the TMUXL27518 provides isolation when the supply voltage is removed ($V_{DD} = 0V$). Without this protection feature, switches can back-power the supply rail through an internal ESD diode and cause potential damage to the system.

The TMUXL27518 allows any SD, SDIO, and multimedia card host controllers to expand out to multiple cards or peripherals because the SDIO interface consists of 6-bits: CMD, CLK, and Data[0:3] signals. This device supports upto 6-bit interfaces such a qSPI eSPI and SPI muxing. The TMUXL27518 has two control pins that give additional flexibility to the user. For example, the ability to mux two different audio-video signals in equipment such as an LCD television, an LCD monitor, or a notebook docking station.

Package Information

PART NUMBER	PACKAGE ⁽¹⁾	PACKAGE SIZE
TMUXL27518	RTW (WQFN, 24)	4mm × 4mm

(1) For more information, see [Section 11](#).

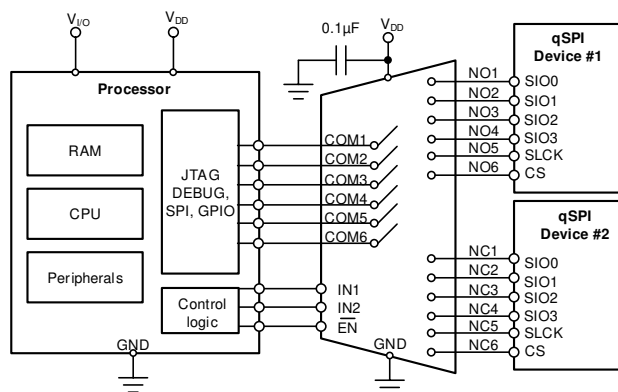

Typical Application

Table of Contents

1 Features	1	7.4 Device Functional Modes.....	24
2 Applications	1	8 Application and Implementation	25
3 Description	1	8.1 Application Information.....	25
4 Pin Configuration and Functions	3	8.2 Typical Application.....	25
5 Specifications	5	8.3 Power Supply Recommendations.....	26
5.1 Absolute Maximum Ratings.....	5	8.4 Layout.....	26
5.2 ESD Ratings.....	5	9 Device and Documentation Support	27
5.3 Recommended Operating Conditions.....	5	9.1 Documentation Support.....	27
5.4 Thermal Information.....	6	9.2 Receiving Notification of Documentation Updates....	27
5.5 Electrical Characteristics for 1.8V Supply.....	7	9.3 Support Resources.....	27
5.6 Electrical Characteristics for 1.2V Supply.....	11	9.4 Trademarks.....	27
5.7 Typical Characteristics.....	16	9.5 Electrostatic Discharge Caution.....	27
6 Parameter Measurement Information	18	9.6 Glossary.....	27
7 Detailed Description	23	10 Revision History	27
7.1 Overview.....	23	11 Mechanical, Packaging, and Orderable Information	27
7.2 Functional Block Diagram.....	23		
7.3 Feature Description.....	23		

4 Pin Configuration and Functions

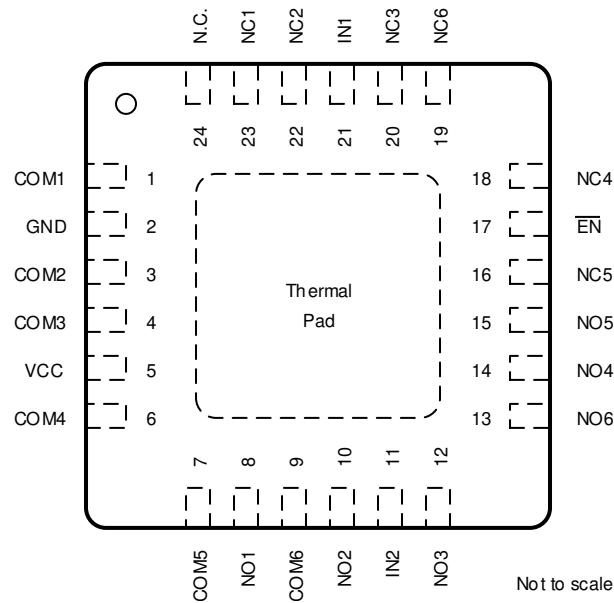

**Figure 4-1. RTW Package
 24-Pin WQFN
 Top View**

Table 4-1. Pin Functions

PIN		TYPE ⁽¹⁾	DESCRIPTION
NAME	RTW		
COM1	1	I/O	Common-signal path
COM2	3	I/O	Common-signal path
COM3	4	I/O	Common-signal path
COM4	6	I/O	Common-signal path
COM5	7	I/O	Common-signal path
COM6	9	I/O	Common-signal path
$\overline{\text{EN}}$	17	I	Digital control to enable or disable all signal paths
GND	2	—	Ground.
IN1	21	I	Digital control to connect COM to NC or NO
IN2	11	I	Digital control to connect COM to NC or NO
N.C.	24	—	Not connected
NC1	23	I/O	Normally closed-signal path
NC2	22	I/O	Normally closed-signal path
NC3	20	I/O	Normally closed-signal path
NC4	18	I/O	Normally closed-signal path
NC5	16	I/O	Normally closed-signal path
NC6	19	I/O	Normally closed-signal path
NO1	8	I/O	Normally open-signal path
NO2	10	I/O	Normally open-signal path
NO3	12	I/O	Normally open-signal path
NO4	14	I/O	Normally open-signal path
NO5	15	I/O	Normally open-signal path
NO6	13	I/O	Normally open-signal path
V _{CC}	5	—	Voltage supply

(1) I/O = input/output

5 Specifications

5.1 Absolute Maximum Ratings

over operating free-air temperature range (unless otherwise noted)⁽¹⁾

			MIN	MAX	UNIT
V_{CC}	Supply voltage		-0.5	2.4	V
V_{NC}, V_{NO}, V_{COM}	Analog Voltage		-0.5	2.4	V
$I_{I/OK}$	Analog port diode current	$V_{NC}, V_{NO}, V_{COM} < 0$	-50	50	
$I_{I/OK}$	Analog port diode current	$V_{NC}, V_{NO}, V_{COM} > V_{CC}$	-50	50	mA
I_{NC}, I_{NO}, I_{COM}	ON-state switch current	$V_{NC}, V_{NO}, V_{COM} = 0$ to VCC	-50	50	mA
V_I	Digital input voltage		-0.5	3.6	V
I_{IK}	Digital input clamp current	$V_I < 0$	-50		mA
I_{CC}, I_{GND}	Continuous current through V_{CC} or GND			100	mA
Storage temperature, T_{stg}			-65	150	°C

- (1) Operation outside the Absolute Maximum Ratings may cause permanent device damage. Absolute Maximum Ratings do not imply functional operation of the device at these or any other conditions beyond those listed under Recommended Operating Conditions. If used outside the Recommended Operating Conditions but within the Absolute Maximum Ratings, the device may not be fully functional, and this may affect device reliability, functionality, performance, and shorten the device lifetime.

5.2 ESD Ratings

			VALUE	UNIT
$V_{(ESD)}$	Electrostatic discharge	Human body model (HBM), per ANSI/ESDA/JEDEC JS-001, all pins ⁽¹⁾	±2000	V
		Charged device model (CDM), per JEDEC specification JESD22-C101, all pins ⁽²⁾	±1000	

- (1) JEDEC document JEP155 states that 500V HBM allows safemanufacturing with a standard ESD control process.
(2) JEDEC document JEP157 states that 250V CDM allows safemanufacturing with a standard ESD control process.

5.3 Recommended Operating Conditions

over operating free-air temperature range (unless otherwise noted)

			MIN	NOM	MAX	UNIT
VCC	Supply voltage		1.08		1.95	V
V_{NC}, V_{NO}, V_{COM}	Signal path voltage		0		1.95	V
V_{IN}	Digital Control Input		0		1.95	V
T_A	Operating free-air temperature		-40		125	°C

5.4 Thermal Information

THERMAL METRIC ⁽¹⁾		TMUXL27518	UNIT
		RTW(WQFN)	
		24 PINS	
$R_{\theta JA}$	Junction-to-ambient thermal resistance	72.14	°C/W
$R_{\theta JC(top)}$	Junction-to-case (top) thermal resistance	58.27	°C/W
$R_{\theta JB}$	Junction-to-board thermal resistance	49.11	°C/W
Ψ_{JT}	Junction-to-top characterization parameter	11.06	°C/W
Ψ_{JB}	Junction-to-board characterization parameter	49.19	°C/W
$R_{\theta JC(bot)}$	Junction-to-case (bottom) thermal resistance	33.72	°C/W

- (1) For more information about traditional and new thermal metrics, see the [Semiconductor and IC Package Thermal Metrics](#) application note.

5.5 Electrical Characteristics for 1.8V Supply

over operating free-air temperature range (unless otherwise noted)

Section	Parameter		Test Conditions	T _A	V _{CC}	MIN	TYP	MAX	UNIT	
V _{COM} , V _{NC} , V _{NO}	Analog Signal Voltage				0			1.95	V	
Analog Switch	R _{on}	ON-state resistance	0 ≤ (V _{NC} or V _{NO}) ≤ V _{CC} , I _{COM} = -32mA,	Switch ON	25°C	1.65V	14	24	Ω	
Analog Switch	R _{on}	ON-state resistance	0 ≤ (V _{NC} or V _{NO}) ≤ V _{CC} , I _{COM} = -32mA,	Switch ON	Full	1.65V		25	Ω	
Analog Switch	ΔR _{on}	ON-state resistance match between channels	V _{NC} or V _{NO} = 1.6V, I _{COM} = -32mA,	Switch ON	25°C	1.65V	0.45	1	Ω	
Analog Switch	ΔR _{on}	ON-state resistance match between channels	V _{NC} or V _{NO} = 1.6V, I _{COM} = -32mA,	Switch ON	Full	1.65V		1.2	Ω	
Analog Switch	R _{on(flat)}	ON-state resistance flatness	0 ≤ (V _{NC} or V _{NO}) ≤ V _{CC} , I _{COM} = -32mA,	Switch ON	25°C	1.65V	7.5	14	Ω	
Analog Switch	R _{on(flat)}	ON-state resistance flatness	0 ≤ (V _{NC} or V _{NO}) ≤ V _{CC} , I _{COM} = -32mA,	Switch ON	Full	1.65V		15	Ω	
Analog Switch	I _{NC(OFF)} , I _{NO(OFF)}	NC, NO OFF Leakage Current	V _{NC} or V _{NO} = 0.3V, V _{COM} =1.65V Or V _{NC} or V _{NO} = 1.65V, V _{COM} =0.3V	Switch OFF	25°C	1.95V	-0.25	0.03	0.25	uA
Analog Switch	I _{NC(OFF)} , I _{NO(OFF)}	NC, NO OFF Leakage Current	V _{NC} or V _{NO} = 0.3V, V _{COM} =1.65V Or V _{NC} or V _{NO} = 1.65V, V _{COM} =0.3V	Switch OFF	Full	1.95	-5	5	uA	

over operating free-air temperature range (unless otherwise noted)

Section	Parameter		Test Conditions		T _A	V _{CC}	MIN	TYP	MAX	UNIT
Analog Switch	$I_{NC(PWROFF)}$ $I_{NO(PWROFF)}$	NC,NO OFF Leakage Current	VNC or VNO = 0 to 1.95, VCOM=1.95 to 0 Or VNC or VNO = 1.95 to 0, VCOM=0 to 1.95	Switch OFF	25°C	0	-0.4	0.01	0.4	uA
Analog Switch	$I_{NC(PWROFF)}$ $I_{NO(PWROFF)}$	NC,NO OFF Leakage Current	VNC or VNO = 0 to 1.95, VCOM=1.95 to 0 Or VNC or VNO = 1.95 to 0, VCOM=0 to 1.95	Switch OFF	Full	0	-7.2		7.2	uA
Analog Switch	$I_{COM(OFF)}$	COM OFF Leakage Current	VNC or VNO = 0.3V, VCOM=1.65V Or VNC or VNO = 1.65V, VCOM=0.3V	Switch OFF	25°C	1.95	-0.4	0.02	0.4	uA
Analog Switch	$I_{COM(OFF)}$	COM OFF Leakage Current	VNC or VNO = 0.3V, VCOM=1.65V Or VNC or VNO = 1.65V, VCOM=0.3V	Switch OFF	Full	1.95	-0.9		0.9	uA
Analog Switch	$I_{COM(PWROFF)}$	COM OFF Leakage Current	VNC or VNO = 0 to 1.95, VCOM=1.95 to 0 Or VNC or VNO = 1.95 to 0, VCOM=0 to 1.95	Switch OFF	25°C	0	-0.4	0.02	0.4	uA

over operating free-air temperature range (unless otherwise noted)

Section	Parameter		Test Conditions		T _A	V _{CC}	MIN	TYP	MAX	UNIT
Analog Switch	I _{COM(PWROF F)}	COM OFF Leakage Current	VNC or VNO = 0 to 1.95, VCOM=1.95 to 0 Or VNC or VNO = 1.95 to 0, VCOM=0 to 1.95	Switch OFF	Full	0	-5		5	uA
Analog Switch	I _{NC(ON),INO(ON)}	NC,NO ON Leakage Current	VNC or VNO = 0.3V, VCOM=Open Or VNC or VNO = 1.65V, VCOM=Open	Switch ON	25°C	1.95	-2	0.02	2	uA
Analog Switch	I _{NC(ON),INO(ON)}	NC,NO ON Leakage Current	VNC or VNO = 0.3V, VCOM=Open Or VNC or VNO = 1.65V, VCOM=Open	Switch ON	Full	1.95	-5.2		5.2	uA
Analog Switch	I _{COM(ON)}	COM ON Leakage Current	VNC or VNO = Open, VCOM=1.65V Or VNC or VNO = Open, VCOM=0.3V	Switch ON	25°C	1.95	-2	0.02	2	uA
Analog Switch	I _{COM(ON)}	COM ON Leakage Current	VNC or VNO = Open, VCOM=1.65V Or VNC or VNO = Open, VCOM=0.3V	Switch ON	Full	1.95	-5.2		5.2	uA
Digital Control Inputs (IN)	V _{IH}	Input logic high			Full	1.95	0.77		3.6	V
Digital Control Inputs (IN)	V _{IL}	Input logic low			Full	1.95	0		0.39	V
Digital Control Inputs (IN)	I _{IH} , I _{IL}	Input leakage current	V _{IN} = V _{CC} or 0		25°C	1.95	-0.1	0.01	0.1	uA

over operating free-air temperature range (unless otherwise noted)

Section	Parameter		Test Conditions		T _A	V _{CC}	MIN	TYP	MAX	UNIT
Digital Control Inputs (IN)	I _{IH} , I _{IL}	Input leakage current	V _{IN} = V _{CC} or 0		Full	1.95	-2.1		2.1	uA
Dynamic	t _{ON}	Turnon time	V _{COM} = V _{CC} , R _L = 50Ω,	C _L = 35pF	-40°C to 125°C	1.65 to 1.95		34	56	ns
Dynamic	t _{OFF}	Turnon time	V _{COM} = V _{CC} , R _L = 50Ω,	C _L = 35pF	-40°C to 125°C	1.65 to 1.95		12	24	ns
Dynamic	t _{BBM}	Break-before-make time	V _{NC} = V _{NO} = V _{CC} /2, R _L = 50Ω,	C _L = 35pF	Full	1.65 to 1.95	11	20		ns
Dynamic	Q _C	Charge injection	V _{GEN} = 0, R _{GEN} = 0	C _L = 0.1nF	25°C	1.8V		1.9		pC
Dynamic	C _{COM(OFF)}	COM OFF capacitance	V _{COM} = V _{CC} or GND, Switch OFF, f = 10MHz		25°C	1.8V		7.8		pF
Dynamic	C _{NC(OFF)} , C _{NO(OFF)}	NC, NO OFF capacitance	V _{NO} or V _{NC} = V _{CC} or GND, Switch OFF, f = 10MHz		25°C	1.8V		4.2		pF
Dynamic	C _{COM(ON)}	COM ON capacitance	V _{COM} = V _{CC} or GND, Switch ON, f = 10MHz		25°C	1.8V		12		pF
Dynamic	C _{NC(ON)} , C _{NO(ON)}	NC, NO ON capacitance	V _{NO} or V _{NC} = V _{CC} or GND, Switch ON, f = 10MHz		25°C	1.8V		12		pF
Dynamic	C _I	Digital input capacitance	V _{IN} = V _{CC} or GND		25°C	1.8V		2		pF
Dynamic	BW	Bandwidth	R _L = 50Ω, -3dB		25°C	1.8V		600		MHz
Dynamic	°ISO	OFF isolation	R _L = 50Ω	f = 10MHz	25°C	1.8V		-53		dB
Dynamic	X _{TALK}	Crosstalk	R _L = 50Ω	f = 10MHz	25°C	1.8V		-54		dB
Dynamic	X _{TALK(ADJ)}	Crosstalk	R _L = 50Ω	f = 10MHz	25°C	1.8V		-56		dB
Dynamic	THD	Total harmonic distortion	R _L = 600Ω, C _L = 50pF,	f = 20Hz to 20kHz	25°C	1.8V		0.1		%
Supply	I _{CC}	Positive supply current	V _{IN} = V _{CC} or GND, V _{NC} and V _{NO} = Floating	Switch ON or OFF	-40°C to 125°C	1.95V			6	μA

5.6 Electrical Characteristics for 1.2V Supply

over operating free-air temperature range (unless otherwise noted)

Section	Parameter	Test Conditions	T _A	V _{CC}	MIN	TYP	MAX	UNIT		
Analog Switch	V _{COM} , V _{NC} , V _{NO}	Analog Signal Voltage			0		1.32	V		
Analog Switch	R _{on}	ON-state resistance	0 ≤ (V _{NC} or V _{NO}) ≤ V _{CC} , I _{COM} = -12mA,	Switch ON	25°C	1.08V	47	81	Ω	
Analog Switch	R _{on}	ON-state resistance	0 ≤ (V _{NC} or V _{NO}) ≤ V _{CC} , I _{COM} = -12mA,	Switch ON	Full	1.08V		85	Ω	
Analog Switch	ΔR _{on}	ON-state resistance match between channels	V _{NC} or V _{NO} = 1.08V, I _{COM} = -12mA,	Switch ON	25°C	1.08V	0.45	1	Ω	
Analog Switch	ΔR _{on}	ON-state resistance match between channels	V _{NC} or V _{NO} = 1.08V, I _{COM} = -12mA,	Switch ON	Full	1.08V		1.2	Ω	
Analog Switch	R _{on(flat)}	ON-state resistance flatness	0 ≤ (V _{NC} or V _{NO}) ≤ V _{CC} , I _{COM} = -12mA,	Switch ON	25°C	1.08V	37	63	Ω	
Analog Switch	R _{on(flat)}	ON-state resistance flatness	0 ≤ (V _{NC} or V _{NO}) ≤ V _{CC} , I _{COM} = -12mA,	Switch ON	Full	1.08V		70	Ω	
Analog Switch	I _{NC(OFF)} , I _{NO(OFF)}	NC, NO OFF Leakage Current	V _{NC} or V _{NO} = 0.24V, V _{COM} = 1.08V Or V _{NC} or V _{NO} = 1.08V, V _{COM} = 0.24V	Switch OFF	25°C	1.32V	-0.25	0.03	0.25	μA
Analog Switch	I _{NC(OFF)} , I _{NO(OFF)}	NC, NO OFF Leakage Current	V _{NC} or V _{NO} = 0.24V, V _{COM} = 1.08V Or V _{NC} or V _{NO} = 1.08V, V _{COM} = 0.24V	Switch OFF	Full	1.32V	-5		5	μA

over operating free-air temperature range (unless otherwise noted)

Section	Parameter		Test Conditions		T _A	V _{CC}	MIN	TYP	MAX	UNIT
Analog Switch	$I_{NC(PWROFF)}$, $I_{NO(PWROFF)}$	NC,NO OFF Leakage Current	VNC or VNO = 0 to 1.32, VCOM=1.32 to 0 Or VNC or VNO = 1.32 to 0, VCOM=0 to 1.32	Switch OFF	25°C	0	-0.4	0.01	0.4	uA
Analog Switch	$I_{NC(PWROFF)}$, $I_{NO(PWROFF)}$	NC,NO OFF Leakage Current	VNC or VNO = 0 to 1.32, VCOM=1.32 to 0 Or VNC or VNO = 1.32 to 0, VCOM=0 to 1.32	Switch OFF	Full	0	-7.2		7.2	uA
Analog Switch	$I_{COM(OFF)}$	COM OFF Leakage Current	VNC or VNO = 0.24V, VCOM=1.08V Or VNC or VNO = 1.08V, VCOM=0.24V	Switch OFF	25°C	1.32V	-0.4	0.02	0.4	uA
Analog Switch	$I_{COM(OFF)}$	COM OFF Leakage Current	VNC or VNO = 0.24V, VCOM=1.08V Or VNC or VNO = 1.08V, VCOM=0.24V	Switch OFF	Full	1.32V	-0.9		0.9	uA
Analog Switch	$I_{COM(PWROFF)}$	COM OFF Leakage Current	VNC or VNO = 0 to 1.32, VCOM=1.32 to 0 Or VNC or VNO = 1.32 to 0, VCOM=0 to 1.32	Switch OFF	25°C	0	-0.4	0.02	0.4	uA

over operating free-air temperature range (unless otherwise noted)

Section	Parameter		Test Conditions		T _A	V _{CC}	MIN	TYP	MAX	UNIT
Analog Switch	I _{COM(PWROFF)}	COM OFF Leakage Current	VNC or VNO = 0 to 1.32, VCOM=1.32 to 0 Or VNC or VNO = 1.32 to 0, VCOM=0 to 1.32	Switch OFF	Full	0	-5		5	uA
Analog Switch	I _{NC(ON),INO(ON)}	NC,NO ON Leakage Current	VNC or VNO = 0.24V, VCOM=Open Or VNC or VNO = 1.08V, VCOM=Open	Switch ON	25°C	1.32V	-2	0.02	2	uA
Analog Switch	I _{NC(ON),INO(ON)}	NC,NO ON Leakage Current	VNC or VNO = 0.24V, VCOM=Open Or VNC or VNO = 1.08V, VCOM=Open	Switch ON	Full	1.32V	-5.2		5.2	uA
Analog Switch	I _{COM(ON)}	COM ON Leakage Current	VNC or VNO = Open, VCOM=1.08V Or VNC or VNO = Open, VCOM=0.24V	Switch ON	25°C	1.32V	-2	0.02	2	uA
Analog Switch	I _{COM(ON)}	COM ON Leakage Current	VNC or VNO = Open, VCOM=1.08V Or VNC or VNO = Open, VCOM=0.24V	Switch ON	Full	1.32V	-5.2		5.2	uA
Digital Control Inputs (IN)	V _{IH}	Input logic high			Full	1.32V	0.8		3.6	V
Digital Control Inputs (IN)	V _{IL}	Input logic low			Full	1.32V	0		0.39	V
Digital Control Inputs (IN)	I _{IH} , I _{IL}	Input leakage current	V _{IN} = V _{CC} or 0		25°C	1.32V	-0.1	0.01	0.1	nA

over operating free-air temperature range (unless otherwise noted)

Section	Parameter		Test Conditions		T _A	V _{CC}	MIN	TYP	MAX	UNIT
Digital Control Inputs (IN)	I _{IH} , I _{IL}	Input leakage current	V _{IN} = V _{CC} or 0		Full	1.32V	-2.1		2.1	nA
Dynamic	t _{ON}	Turnon time	V _{COM} = V _{CC} , R _L = 50Ω,	C _L = 35pF	-40°C to 125°C	1.08 to 1.32		60	165	ns
Dynamic	t _{OFF}	Turnon time	V _{COM} = V _{CC} , R _L = 50Ω,	C _L = 35pF	-40°C to 125°C	1.08 to 1.32		27	50	ns
Dynamic	t _{BBM}	Break-before-make time	V _{NC} = V _{NO} = V _{CC} /2, R _L = 50Ω,	C _L = 35pF	25°C	1.2		20	39	ns
Dynamic	t _{BBM}	Break-before-make time	V _{NC} = V _{NO} = V _{CC} /2, R _L = 50Ω,	C _L = 35pF	Full	1.08 to 1.32		17		ns
Dynamic	Q _C	Charge injection	V _{GEN} = 0, R _{GEN} = 0	C _L = 0.1nF	25°C	1.2V		0.5		pC
Dynamic	C _{COM(OFF)}	COM OFF capacitance	V _{COM} = V _{CC} or GND, Switch OFF, f = 10MHz		25°C	1.2V		8		pF
Dynamic	C _{N(OFF)} , C _{NO(OFF)}	NC, NO OFF capacitance	V _{NO} or V _{NC} = V _{CC} or GND, Switch OFF, f = 10MHz		25°C	1.2V		4		pF
Dynamic	C _{COM(ON)}	COM ON capacitance	V _{COM} = V _{CC} or GND, Switch ON, f = 10MHz		25°C	1.2V		12		pF
Dynamic	C _{N(ON)} , C _{NO(ON)}	NC, NO ON capacitance	V _{NO} or V _{NC} = V _{CC} or GND, Switch ON, f = 10MHz		25°C	1.2V		12		pF
Dynamic	C _I	Digital input capacitance	V _{IN} = V _{CC} or GND		25°C	1.2V		2		pF
Dynamic	BW	Bandwidth	R _L = 50Ω, -3dB		25°C	1.2V		1000		MHz
Dynamic	Q _{ISO}	OFF isolation	R _L = 50Ω	f = 10MHz,	25°C	1.2V		-51		dB
Dynamic	X _{TALK}	Crosstalk	R _L = 50Ω	f = 10MHz,	25°C	1.2V		-54		dB
Dynamic	X _{TALK(ADJ)}	Crosstalk	R _L = 50Ω	f = 10MHz,	25°C	1.2V		-57		dB

over operating free-air temperature range (unless otherwise noted)

Section	Parameter		Test Conditions		T _A	V _{CC}	MIN	TYP	MAX	UNIT
Supply	I _{CC}	Positive supply current	V _{IN} = V _{CC} or GND, V _{NC} and V _{NO} = Floating	Switch ON or OFF	–40°C to 125°C	1.32V			6	μA

5.7 Typical Characteristics

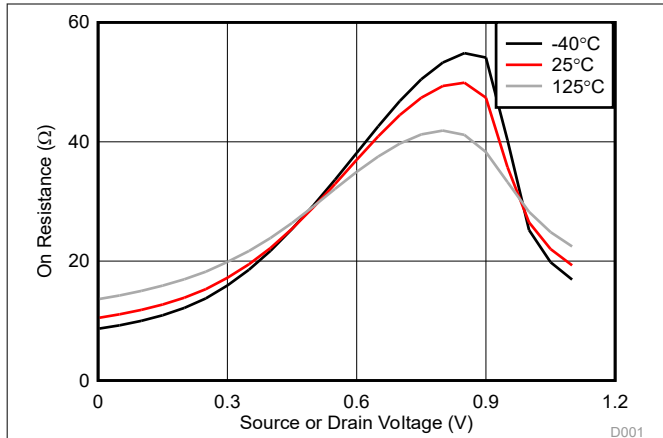

Figure 5-1. On-Resistance vs Source or Drain Voltage (VCC = 1.2V)

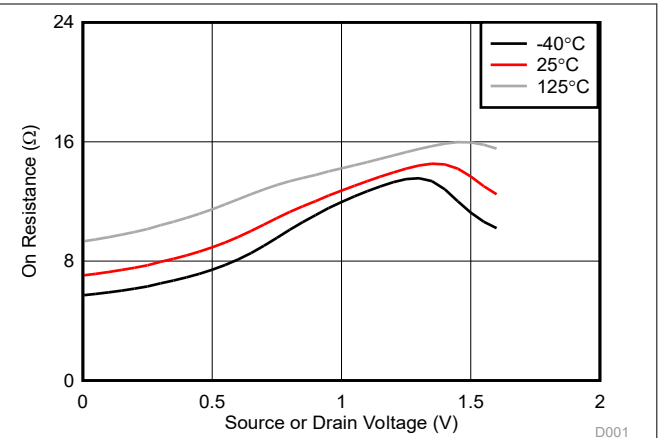

Figure 5-2. On-Resistance vs Source or Drain Voltage (VCC = 1.8V)

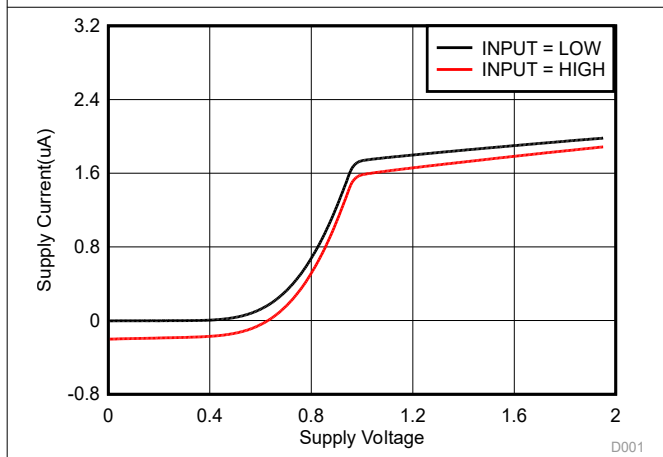

Figure 5-3. Supply Current vs Supply Voltage

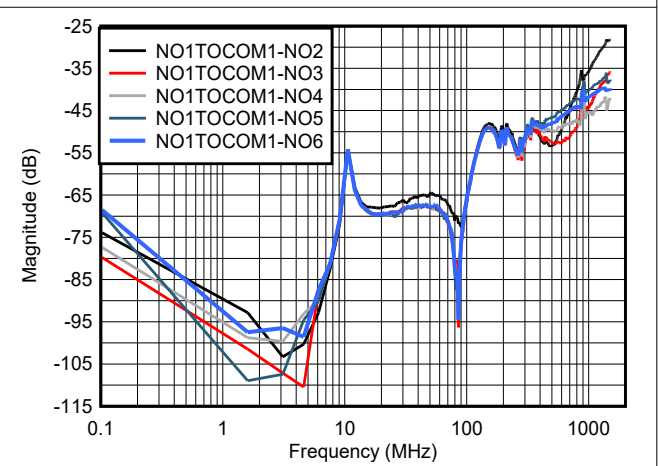

Figure 5-4. Crosstalk Adjacent

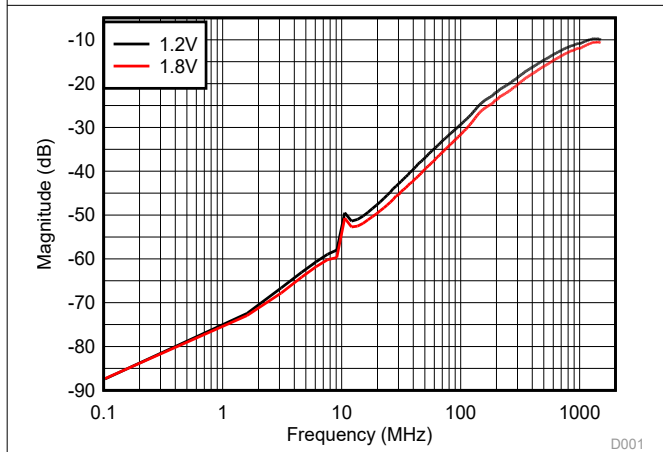

Figure 5-5. OFF Isolation

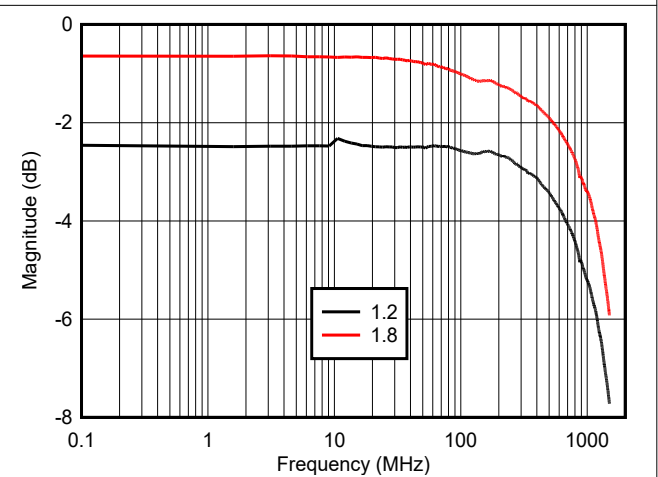
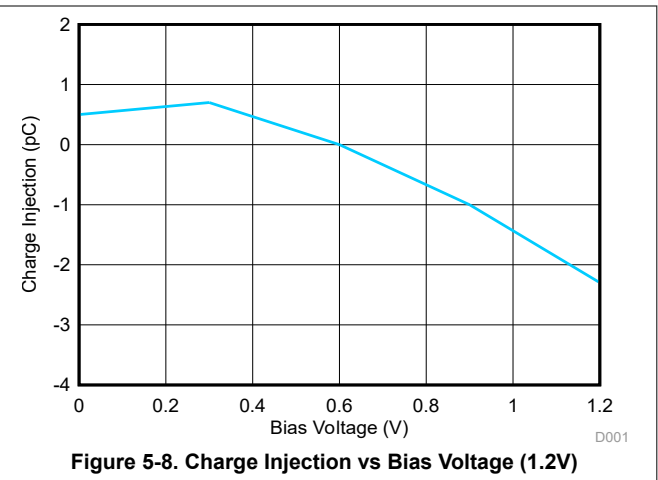
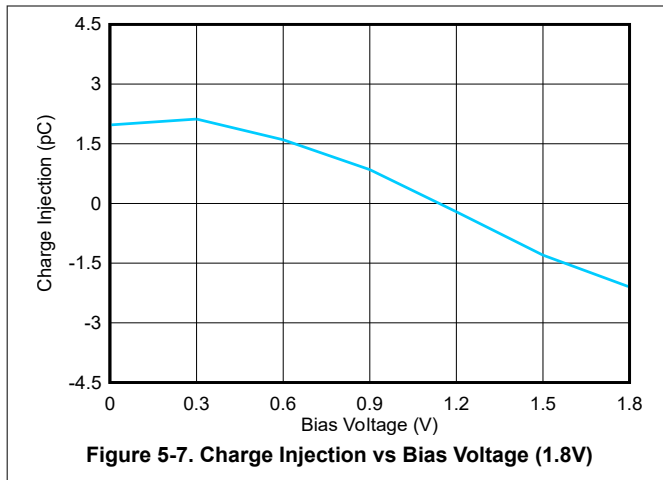

Figure 5-6. Insertion Loss

5.7 Typical Characteristics (continued)



6 Parameter Measurement Information

Table 6-1. Parameter Description

DESCRIPTION	
V_{COM}	Voltage at COM.
V_{NC}	Voltage at NC.
V_{NO}	Voltage at NO.
r_{on}	Resistance between COM and NC or NO ports when the channel is ON.
Δr_{on}	Difference of r_{on} between channels in a specific device.
$r_{on(Flat)}$	Difference between the maximum and minimum value of r_{on} in a channel over the specified range of conditions.
$I_{NC(OFF)}$	Leakage current measured at the NC port, with the corresponding channel (NC to COM) in the OFF state.
$I_{NC(ON)}$	Leakage current measured at the NC port, with the corresponding channel (NC to COM) in the ON state and the output (COM) open.
$I_{NO(OFF)}$	Leakage current measured at the NO port, with the corresponding channel (NO to COM) in the OFF state.
$I_{NO(ON)}$	Leakage current measured at the NO port, with the corresponding channel (NO to COM) in the ON state and the output (COM) open.
$I_{COM(OFF)}$	Leakage current measured at the COM port, with the corresponding channel (COM to NC or NO) in the OFF state.
$I_{COM(ON)}$	Leakage current measured at the COM port, with the corresponding channel (COM to NC or NO) in the ON state and the output (NC or NO) open.
V_{IH}	Minimum input voltage for logic high for the control input (IN, \overline{EN}).
V_{IL}	Maximum input voltage for logic low for the control input (IN, \overline{EN}).
V_I	Voltage at the control input (IN, \overline{EN}).
I_{IH}, I_{IL}	Leakage current measured at the control input (IN, \overline{EN}).
t_{ON}	Turnon time for the switch. This parameter is measured under the specified range of conditions and by the propagation delay between the digital control (IN) signal and analog output (NC or NO) signal when the switch is turning ON.
t_{OFF}	Turnoff time for the switch. This parameter is measured under the specified range of conditions and by the propagation delay between the digital control (IN) signal and analog output (NC or NO) signal when the switch is turning OFF.
Q_C	Charge injection is a measurement of unwanted signal coupling from the control (IN) input to the analog (NC or NO) output. This is measured in coulomb (C) and measured by the total charge induced due to switching of the control input. Charge injection, $Q_C = C_L \times \Delta V_{COM}$, C_L is the load capacitance, and ΔV_{COM} is the change in analog output voltage.
$C_{NC(OFF)}$	Capacitance at the NC port when the corresponding channel (NC to COM) is OFF.
$C_{NC(ON)}$	Capacitance at the NC port when the corresponding channel (NC to COM) is ON.
$C_{NO(OFF)}$	Capacitance at the NC port when the corresponding channel (NO to COM) is OFF.
$C_{NO(ON)}$	Capacitance at the NC port when the corresponding channel (NO to COM) is ON.
$C_{COM(OFF)}$	Capacitance at the COM port when the corresponding channel (COM to NC) is OFF.
$C_{COM(ON)}$	Capacitance at the COM port when the corresponding channel (COM to NC) is ON.
C_I	Capacitance of control input (IN, \overline{EN}).
O_{ISO}	OFF isolation of the switch is a measurement of OFF-state switch impedance. This is measured in dB in a specific frequency, with the corresponding channel (NC to COM) in the OFF state.
X_{TALK}	Crosstalk is a measurement of unwanted signal coupling from an ON channel to an OFF channel (NC1 to NO1). Adjacent crosstalk is a measure of unwanted signal coupling from an ON channel to an adjacent ON channel (NC1 to NC2). This is measured in a specific frequency and in dB.
BW	Bandwidth of the switch. This is the frequency in which the gain of an ON channel is -3 dB below the DC gain.
THD	Total harmonic distortion describes the signal distortion caused by the analog switch. This is defined as the ratio of root mean square (RMS) value of the second, third, and higher harmonic to the absolute magnitude of the fundamental harmonic.
I_{CC}	Static power-supply current with the control (IN) pin at V_{CC} or GND.

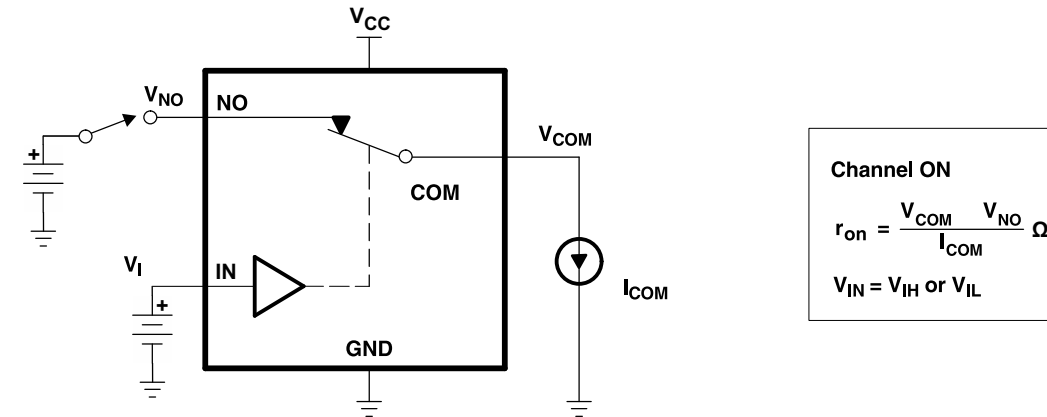

Figure 6-1. ON-State Resistance (r_{ON})

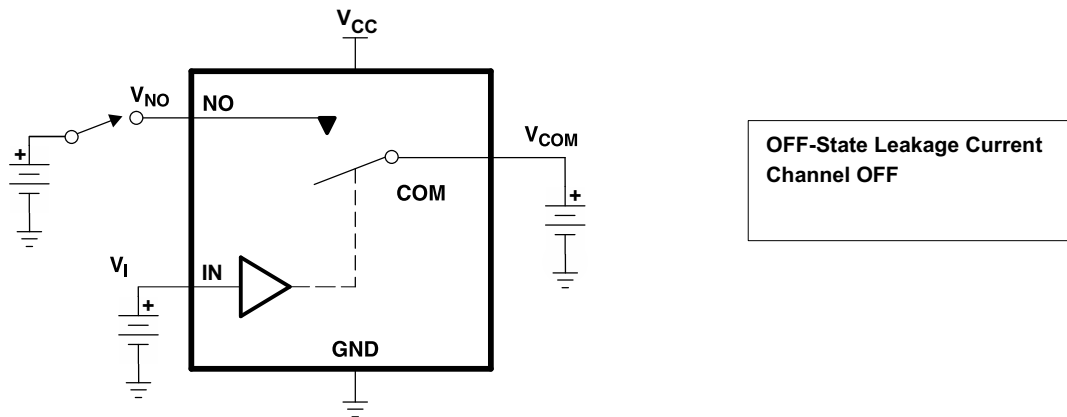

Figure 6-2. OFF-State Leakage Current ($I_{COM(OFF)}$, $I_{NC(OFF)}$, $I_{COM(PWROFF)}$, $I_{NC(PWROFF)}$)

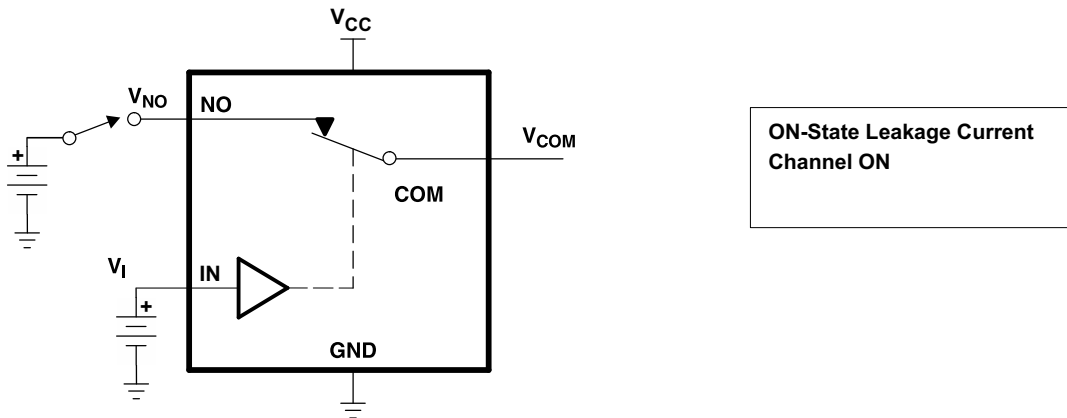

Figure 6-3. ON-State Leakage Current ($I_{COM(ON)}$, $I_{NC(ON)}$)

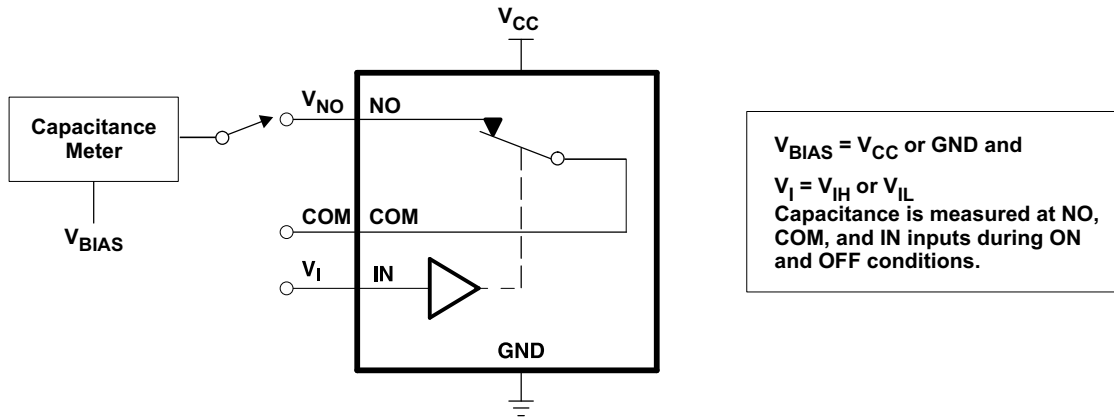
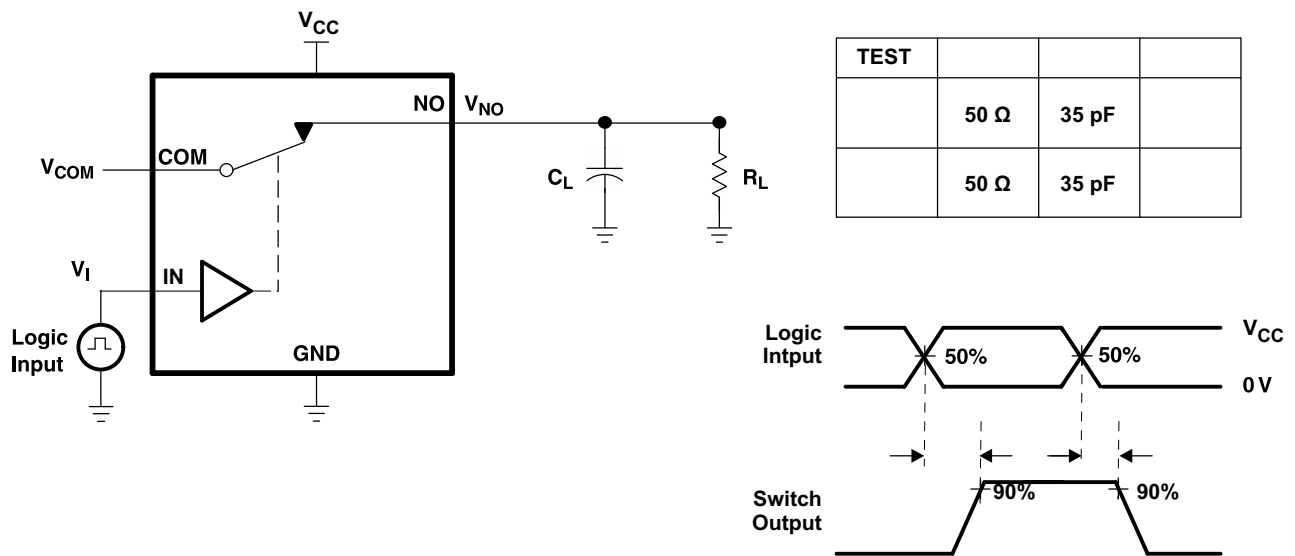
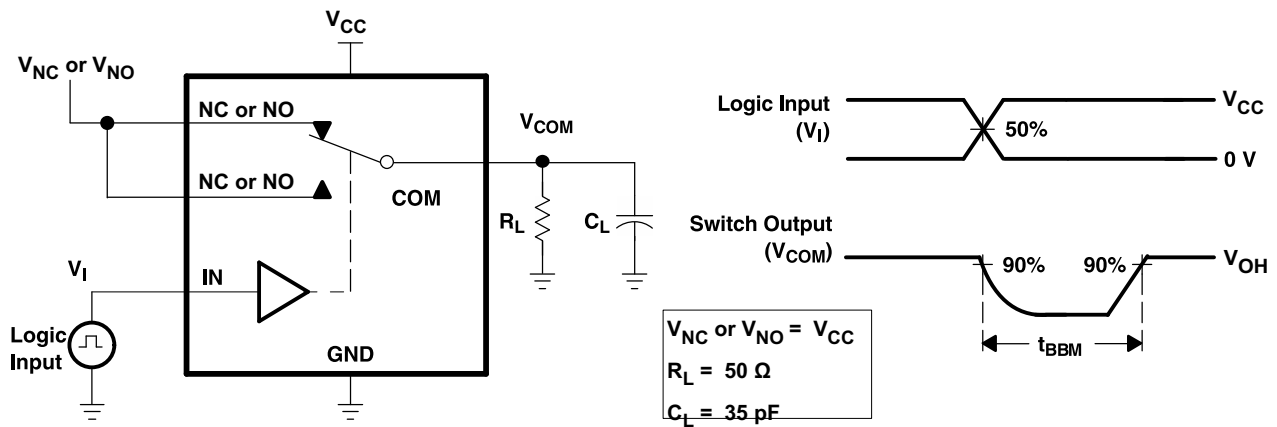

Figure 6-4. Capacitance (C_I , $C_{COM(OFF)}$, $C_{COM(ON)}$, $C_{NC(OFF)}$, $C_{NC(ON)}$)



All input pulses are supplied by generators having the following characteristics: PRR \leq 10MHz, $Z_O = 50\Omega$, $t_r < 5ns$, $t_f < 5ns$. C_L includes probe and jig capacitance.

Figure 6-5. Turnon (t_{ON}) and Turnoff Time (t_{OFF})



C_L includes probe and jig capacitance.

All input pulses are supplied by generators having the following characteristics: PRR \leq 10MHz, $Z_O = 50\Omega$, $t_r < 5ns$, $t_f < 5ns$.

Figure 6-6. Break-Before-Make Time (t_{BBM})

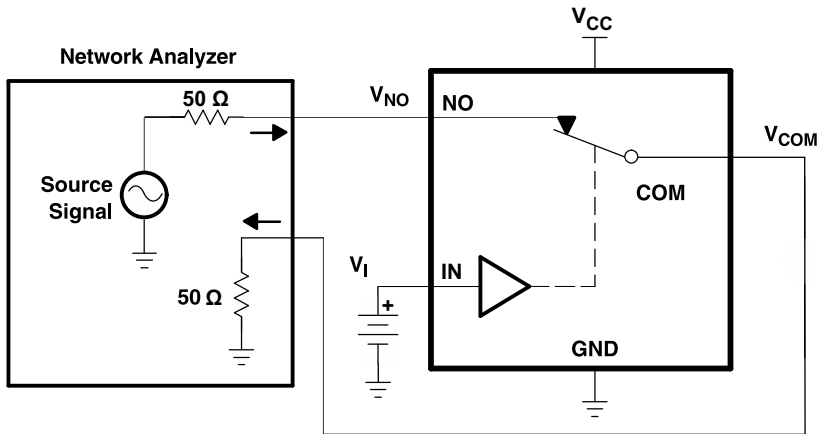

Figure 6-7. Bandwidth (BW)

Channel ON: NO to COM
 $V_I = V_{IH}$ or V_{IL}

Network Analyzer Setup
 Source Power = 0 dBm
 (632-mV P-P at 50-Ω load)
 DC Bias = 350 mV

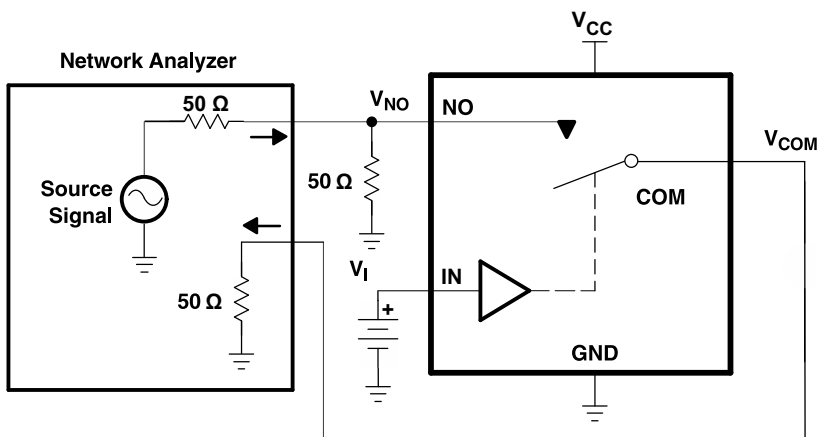

Figure 6-8. OFF Isolation (O_{ISO})

Channel OFF: NO to COM
 $V_I = V_{IH}$ or V_{IL}

Network Analyzer Setup
 Source Power = 0 dBm
 (632-mV P-P at 50-Ω load)
 DC Bias = 350 mV

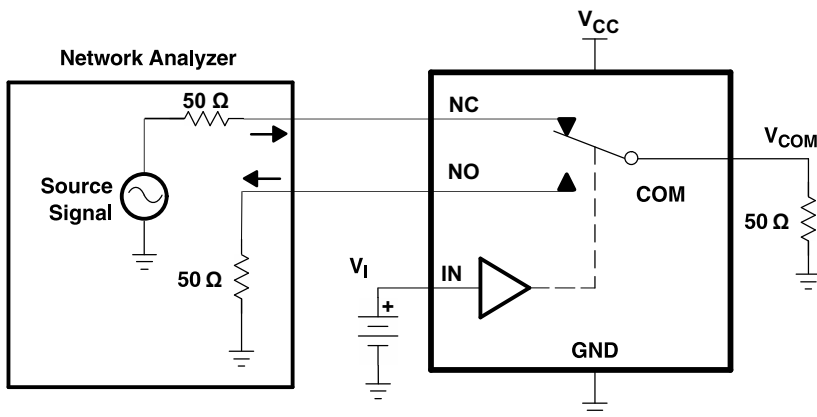
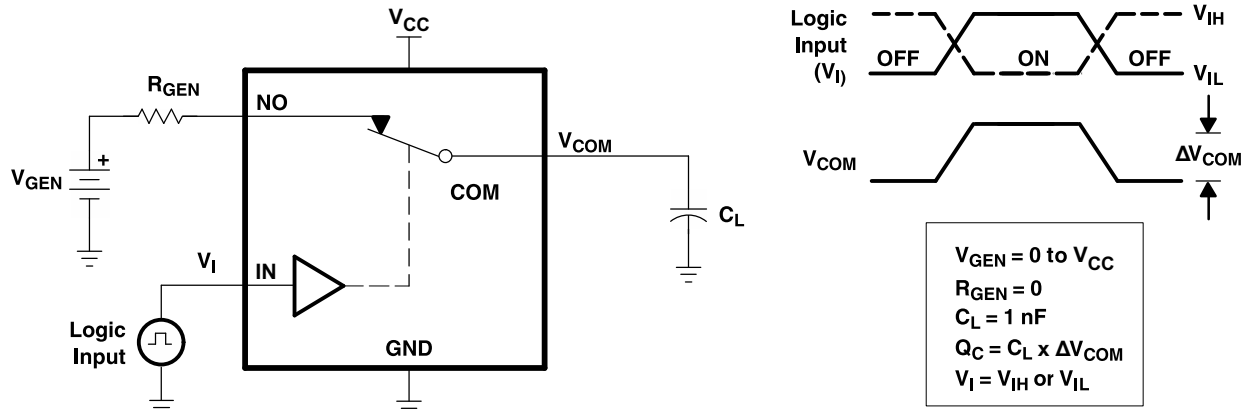

Figure 6-9. Crosstalk (X_{TALK})

Channel ON: NC to COM
Channel OFF: NO to COM
 $V_I = V_{IH}$ or V_{IL}

Network Analyzer Setup
 Source Power = 0 dBm
 (632-mV P-P at 50-Ω load)
 DC Bias = 350 mV



All input pulses are supplied by generators having the following characteristics: PRR \leq 10MHz, $Z_O = 50\Omega$, $t_r < 5\text{ns}$, $t_f < 5\text{ns}$. C_L includes probe and jig capacitance.

Figure 6-10. Charge Injection (Q_C)

Channel ON: COM to NO	$V_I = V_{IH} \text{ or } V_{IL}$	$R_L = 600 \Omega$
$V_{SOURCE} = V_{CC} \text{ P-P}$	$f_{SOURCE} = 20 \text{ Hz to } 20 \text{ kHz}$	$C_L = 50 \text{ pF}$

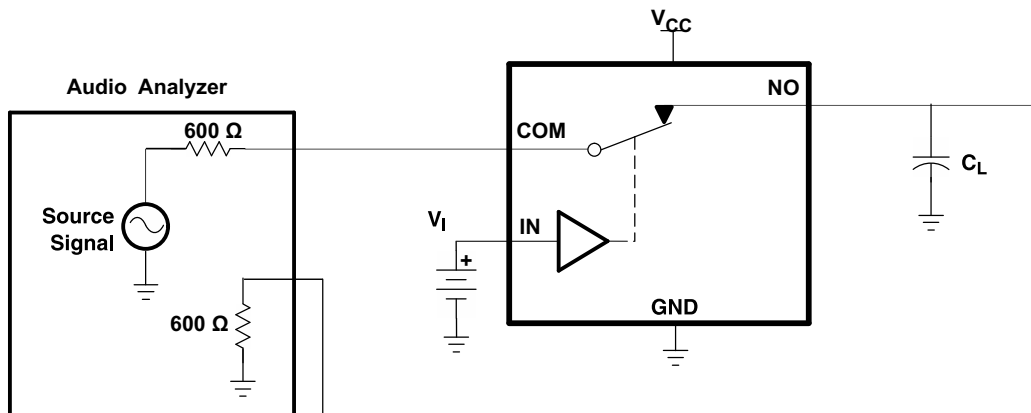

C_L includes probe and jig capacitance.

Figure 6-11. Total Harmonic Distortion (THD)

7 Detailed Description

7.1 Overview

The TMUXL27518 is a bidirectional, 6-channel, 1:2 multiplexer-demultiplexer designed to operate from 1.08V to 1.95V. This device can handle both digital and analog signals, and can transmit signals up to V_{CC} in either direction. The TMUXL27518 has two control pins, each controlling three 1:2 muxes at the same time, and an enable pin that put all outputs in high-impedance mode. The control pins are compatible with 1.2V logic thresholds across supply voltage range of the device eliminating the need of external logic translation.

Powered-off Protection up to 1.95V on the signal path of the TMUXL27518 provides isolation when the supply voltage is removed ($V_{DD} = 0\text{ V}$). Without this protection feature, switches can back-power the supply rail through an internal ESD diode and cause potential damage to the system

The TMUXL27518 allows any SD, SDIO, and multimedia card host controllers to expand out to multiple cards or peripherals because the SDIO interface consists of 6-bits: CMD, CLK, and Data[0:3] signals. This device supports upto 6-bit interfaces such a qSPI eSPI and SPI muxing. The TMUXL27518 has two control pins that give additional flexibility to the user. For example, the ability to mux two different audio-video signals in equipment such as an LCD television, an LCD monitor, or a notebook docking station.

7.2 Functional Block Diagram

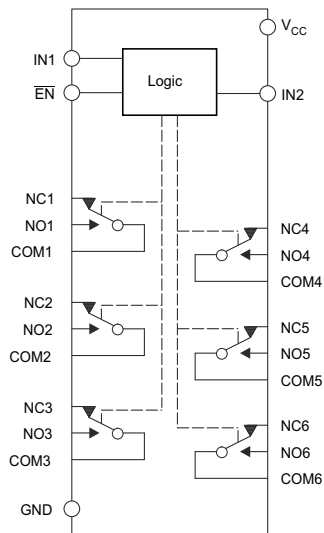

Copyright © 2016, Texas Instruments Incorporated

7.3 Feature Description

The isolation in power-down mode, $V_{CC} = 0$ feature places all switch paths in high-impedance state (High-Z) when the supply voltage equals 0V. When $V_{CC} = 0$, there is no high leakage even when IO voltages go till 3.6V.

7.3.1 1.2V Compatible Logic Control

The TMUXL27518 has 1.2V logic compatible control inputs. Regardless of the VDD voltage, the control input thresholds remain fixed, allowing a 1.2V low nm processor IO to control the TMUXL27518 without the need for an external translator.

7.4 Device Functional Modes

The TMUXL27518 is a bidirectional device that has two sets of three single-pole double-throw switches. Two digital signals control the 6 channels of the switch; one digital control for each set of three single-pole, double-throw switches. Digital input pin IN1 controls switches 1, 2, and 3, while pin IN2 controls switches 4, 5, and 6.

The TMUXL27518 has an \overline{EN} pin that when set to logic high, it places all channels into a high-impedance or HIGH-Z state. [Table 7-1](#) lists the functions of TMUXL27518.

Table 7-1. Function Table

EN	IN1	IN2	NC1/2/3 TO COM1/2/3, COM1/2/3 TO NC1/2/3	NC4/5/6 TO COM4/5/6, COM4/5/6 TO NC4/5/6	NO1/2/3 TO COM1/2/3, COM1/2/3 TO NO1/2/3	NO4/5/6 TO COM4/5/6, COM4/5/6 TO NO4/5/6
H	X	X	OFF	OFF	OFF	OFF
L	L	L	ON	ON	OFF	OFF
L	H	L	OFF	ON	ON	OFF
L	L	H	ON	OFF	OFF	ON
L	H	H	OFF	OFF	ON	ON

8 Application and Implementation

Note

Information in the following applications sections is not part of the TI component specification, and TI does not warrant its accuracy or completeness. TI's customers are responsible for determining suitability of components for their purposes, as well as validating and testing their design implementation to confirm system functionality.

8.1 Application Information

The switches are bidirectional, so the NO, NC, and COM pins can be used as either inputs or outputs. This functionality allows port expansion to support many different types of bidirectional signal interfaces such as SD, SDIO, GPIO, MMC, and qSPI.

8.2 Typical Application

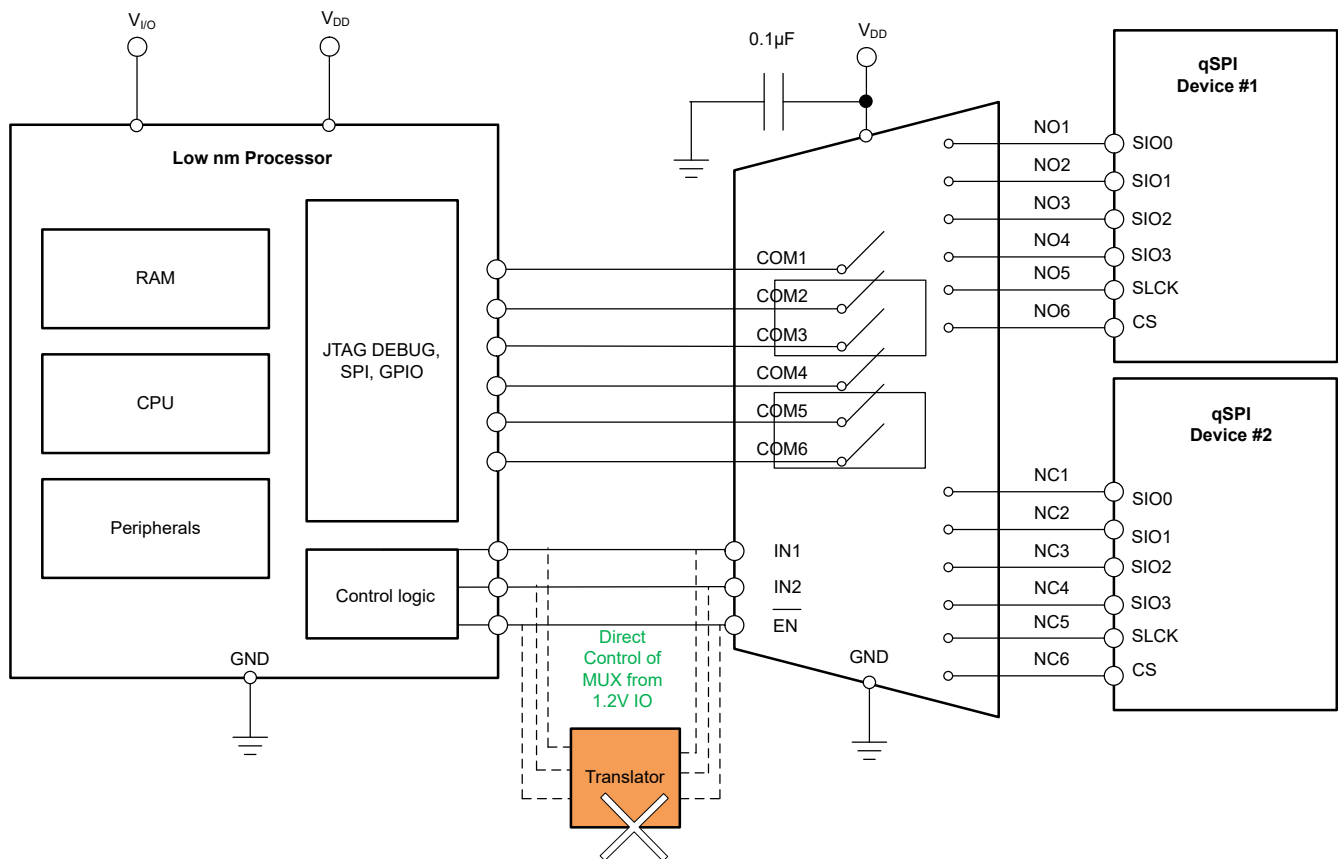

Figure 8-1. qSPI Expander Application Block Diagram

8.2.1 Design Requirement

Ensure that all of the signals passing through the switch are within the recommended operating ranges to ensure proper performance, see [Section 5.3](#).

8.2.2 Detailed Design Procedure

The TMUXL27518 can be properly operated without any external components. However, TI recommends connecting unused pins to the ground through a 50Ω resistor to prevent signal reflections back into the device. TI also recommends that the digital control pins (INX) be pulled up to V_{CC} or down to GND to avoid undesired switch positions that could result from the floating pin. Refer to the [Enabling SPI-Based Flash Memory Expansion by Using Multiplexers application brief](#) for more information on using switches and multiplexers for SPI protocol expansion.

For the RTW package, connect the thermal pad to ground.

8.3 Power Supply Recommendations

TI recommends proper power-supply sequencing for all CMOS devices. Do not exceed the absolute maximum ratings, because stresses beyond the listed ratings can cause permanent damage to the device. Always sequence V_{CC} on first, followed by NO, NC, or COM. Although it is not required, power-supply bypassing improves noise margin and prevents switching noise propagation from the V_{CC} supply to other components. A 0.1-μF capacitor is adequate for most applications, if connected from V_{CC} to GND.

8.4 Layout

8.4.1 Layout Guidelines

To ensure reliability of the device, TI recommends following these common printed-circuit board layout guidelines:

- Bypass capacitors must be used on power supplies, and must be placed as close as possible to the V_{CC} pin.
- Short trace-lengths must be used to avoid excessive loading.
- For the RTW package, connect the thermal pad to ground.

8.4.2 Layout Example

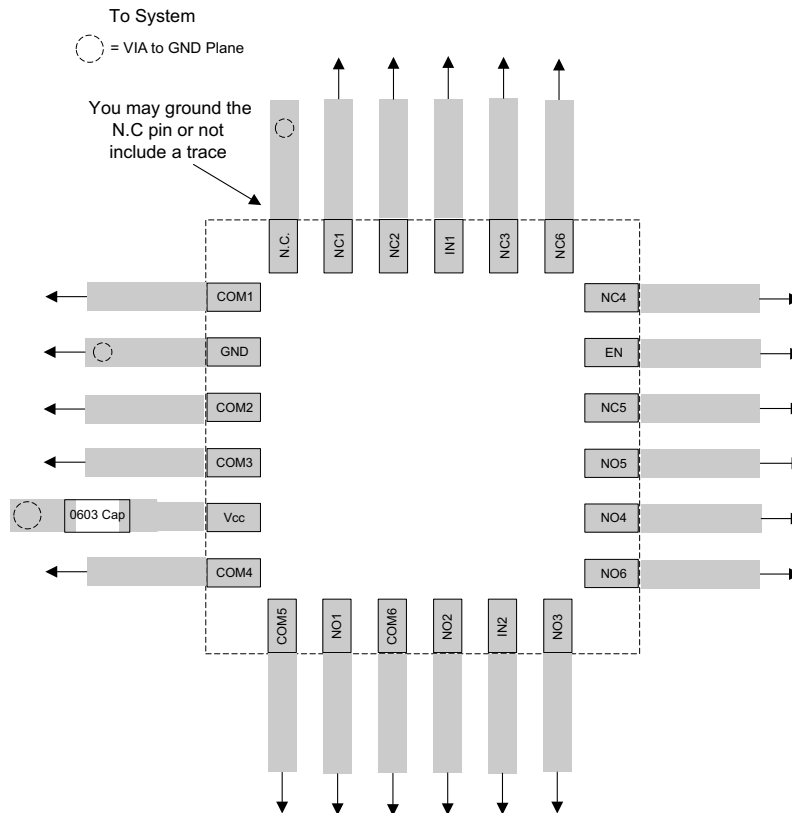

Figure 8-2. WQFN Layout Recommendation

9 Device and Documentation Support

9.1 Documentation Support

9.1.1 Related Documentation

For related documentation, see the following:

- Texas Instruments, [Enabling SPI-Based Flash Memory Expansion by Using Multiplexers application brief](#)

9.2 Receiving Notification of Documentation Updates

To receive notification of documentation updates, navigate to the device product folder on ti.com. Click on *Notifications* to register and receive a weekly digest of any product information that has changed. For change details, review the revision history included in any revised document.

9.3 Support Resources

[TI E2E™ support forums](#) are an engineer's go-to source for fast, verified answers and design help — straight from the experts. Search existing answers or ask your own question to get the quick design help you need.

Linked content is provided "AS IS" by the respective contributors. They do not constitute TI specifications and do not necessarily reflect TI's views; see TI's [Terms of Use](#).

9.4 Trademarks

TI E2E™ is a trademark of Texas Instruments.

All trademarks are the property of their respective owners.

9.5 Electrostatic Discharge Caution



This integrated circuit can be damaged by ESD. Texas Instruments recommends that all integrated circuits be handled with appropriate precautions. Failure to observe proper handling and installation procedures can cause damage.

ESD damage can range from subtle performance degradation to complete device failure. Precision integrated circuits may be more susceptible to damage because very small parametric changes could cause the device not to meet its published specifications.

9.6 Glossary

[TI Glossary](#) This glossary lists and explains terms, acronyms, and definitions.

10 Revision History

NOTE: Page numbers for previous revisions may differ from page numbers in the current version.

DATE	REVISION	NOTES
May 2026	*	Initial Release

11 Mechanical, Packaging, and Orderable Information

The following pages include mechanical, packaging, and orderable information. This information is the most current data available for the designated devices. This data is subject to change without notice and revision of this document. For browser-based versions of this data sheet, refer to the left-hand navigation.

IMPORTANT NOTICE AND DISCLAIMER

TI PROVIDES TECHNICAL AND RELIABILITY DATA (INCLUDING DATASHEETS), DESIGN RESOURCES (INCLUDING REFERENCE DESIGNS), APPLICATION OR OTHER DESIGN ADVICE, WEB TOOLS, SAFETY INFORMATION, AND OTHER RESOURCES "AS IS" AND WITH ALL FAULTS, AND DISCLAIMS ALL WARRANTIES, EXPRESS AND IMPLIED, INCLUDING WITHOUT LIMITATION ANY IMPLIED WARRANTIES OF MERCHANTABILITY, FITNESS FOR A PARTICULAR PURPOSE OR NON-INFRINGEMENT OF THIRD PARTY INTELLECTUAL PROPERTY RIGHTS.

These resources are intended for skilled developers designing with TI products. You are solely responsible for (1) selecting the appropriate TI products for your application, (2) designing, validating and testing your application, and (3) ensuring your application meets applicable standards, and any other safety, security, regulatory or other requirements.

These resources are subject to change without notice. TI grants you permission to use these resources only for development of an application that uses the TI products described in the resource. Other reproduction and display of these resources is prohibited. No license is granted to any other TI intellectual property right or to any third party intellectual property right. TI disclaims responsibility for, and you fully indemnify TI and its representatives against any claims, damages, costs, losses, and liabilities arising out of your use of these resources.

TI's products are provided subject to [TI's Terms of Sale](#), [TI's General Quality Guidelines](#), or other applicable terms available either on [ti.com](#) or provided in conjunction with such TI products. TI's provision of these resources does not expand or otherwise alter TI's applicable warranties or warranty disclaimers for TI products. Unless TI explicitly designates a product as custom or customer-specified, TI products are standard, catalog, general purpose devices.

TI objects to and rejects any additional or different terms you may propose.

Copyright © 2026, Texas Instruments Incorporated

Last updated 10/2025