

3.3-V/5-V Input, D-CAP+™ Mode Synchronous Step-Down Integrated FETs Converter With 2-Bit VID

Check for Samples: [TPS51462](#)

FEATURES

- **Integrated FETs Converter w/TI Proprietary D-CAP+™ Mode Architecture**
- **Minimum External Parts Count**
- **Support all MLCC Output Capacitor and SP/POSCAP**
- **Auto Skip Mode**
- **Selectable 700-kHz and 1-MHz Frequency**
- **Small 4 mm × 4 mm, 24-Pin, QFN Package**

APPLICATIONS

- **Low-Voltage Applications Stepping Down from 5-V or 3.3-V Rail**
- **Notebook/Desktop Computers**

DESCRIPTION

The TPS51462 is a fully integrated synchronous buck regulator employing D-CAP+™. It is used for up to 5-V step-down where system size is at its premium, performance and optimized BOM are must-haves.

This device fully supports Intel system agent applications with integrated 2-bit VID function.

The TPS51462 also features two switching frequency settings (700 kHz and 1 MHz), skip mode, pre-bias startup, programmable external capacitor soft-start time/voltage transition time, output discharge, internal VBST Switch, 2-V reference ($\pm 1\%$), power good and enable.

The TPS51462 is available in a 4 mm × 4 mm, 24-pin, QFN package (Green RoHs compliant and Pb free) and is specified from -40°C to 85°C .

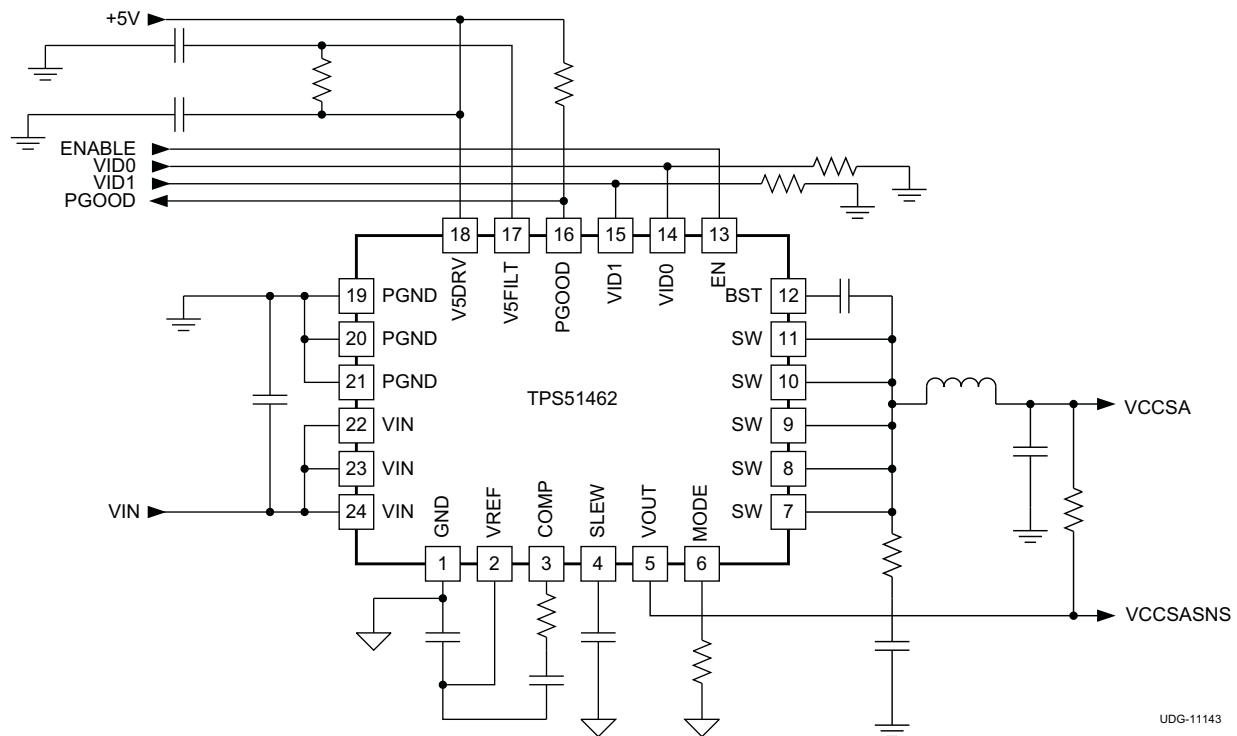

Please be aware that an important notice concerning availability, standard warranty, and use in critical applications of Texas Instruments semiconductor products and disclaimers thereto appears at the end of this data sheet.

D-CAP+ is a trademark of Texas Instruments.



These devices have limited built-in ESD protection. The leads should be shorted together or the device placed in conductive foam during storage or handling to prevent electrostatic damage to the MOS gates.

ORDERING INFORMATION⁽¹⁾

T _A	PACKAGE ⁽²⁾	ORDERING NUMBER	PINS	OUTPUT SUPPLY	MINIMUM QUANTITY	ECO PLAN
-40°C to 85°C	Plastic QFN (RGE)	TPS51462RGER	24	Tape and reel	3000	Green (RoHS and no Pb/Br)
		TPS51462RGET	24	Mini reel	250	

- (1) For the most current package and ordering information, see the *Package Option Addendum* at the end of this document, or visit the TI website at www.ti.com.
- (2) Package drawings, standard packing quantities, thermal data, symbolization, and PCB design guidelines are available at www.ti.com/sc/package.

THERMAL INFORMATION

THERMAL METRIC ⁽¹⁾		TPS51462	UNITS
		RGE (24) PIN	
θ _{JA}	Junction-to-ambient thermal resistance	38.3	°C/W
θ _{JCtop}	Junction-to-case (top) thermal resistance	44.7	
θ _{JB}	Junction-to-board thermal resistance	16	
ψ _{JT}	Junction-to-top characterization parameter	0.8	
ψ _{JB}	Junction-to-board characterization parameter	16.1	
θ _{JCbot}	Junction-to-case (bottom) thermal resistance	5.4	

- (1) For more information about traditional and new thermal metrics, see the *IC Package Thermal Metrics* application report, SPRA953.

ABSOLUTE MAXIMUM RATINGS⁽¹⁾

over operating free-air temperature range (unless otherwise noted)

		VALUE		UNIT
		MIN	MAX	
Input voltage range	VIN, EN, MODE	-0.3	7.0	V
	V5DRV, V5FILT, VBST (with respect to SW)	-0.3	7.0	
	VBST	-0.3	12.5	
	VID0, VID1	-0.3	3.6	
	VOUT	-1.0	3.6	
Output voltage range	SW	-2.0	7.0	V
	SW (transient 20 ns and E=5 μJ)	-3.5		
	COMP, SLEW, VREF	-0.3	3.6	
	PGND	-0.3	0.3	
	PGOOD	-0.3	7.0	
Electrostatic Discharge	Human Body Model (HBM)		2000	V
	Charged Device Model (CDM)		500	
Storage temperature	T _{stg}	-55	150	°C
Junction temperature	T _J	-40	150	°C
Lead temperature 1,6 mm (1/16 inch) from case for 10 seconds			300	°C

- (1) Stresses beyond those listed under “absolute maximum ratings” may cause permanent damage to the device. These are stress ratings only and functional operation of the device at these or any other conditions beyond those indicated under “recommended operating conditions” is not implied. Exposure to absolute-maximum-rated conditions for extended periods may affect device reliability.

RECOMMENDED OPERATING CONDITIONS

		VALUE			UNIT
		MIN	TYP	MAX	
Input voltage range	VIN, EN, MODE	-0.1		6.5	V
	V5DRV, V5FILT, VBST(with respect to SW)	-0.1		5.5	
	VBST	-0.1		11.75	
	VID0, VID1	-0.1		3.5	
	VOUT	-0.8		2.0	
Output voltage range	SW	-0.8		6.5	V
	COMP, SLEW, VREF	-0.1		3.5	
	PGOOD	-0.1		6.5	
	PGND	-0.1		0.1	
Ambient temperature range, T _A		-40		85	°C

ELECTRICAL CHARACTERISTICS

over recommended free-air temperature range, V_{VIN} = 5.0 V, V_{V5DRV} = V_{V5FILT} = 5 V, MODE = OPEN, PGND = GND (unless otherwise noted)

PARAMETER	CONDITIONS	MIN	TYP	MAX	UNIT		
SUPPLY: VOLTAGE, CURRENTS AND 5 V UVLO							
I _{VINSD}	VIN shutdown current	EN = 'LO'		0.02	5	μA	
V _{5VIN}	5VIN supply voltage	V5DRV and V5FILT voltage range		4.5	5.0	5.5	V
I _{5VIN}	5VIN supply current	EN = 'HI', V5DRV + V5FILT supply current		1.6	3.0		mA
I _{5VINS}	5VIN shutdown current	EN = 'LO', V5DRV + V5FILT shutdown current		10	50		μA
V _{5VUVLO}	V5FILT UVLO	Ramp up; EN = 'HI'		4.2	4.3	4.5	V
V _{5VUHYS}	V5FILT UVLO hysteresis	Falling hysteresis		440			mV
V _{VREFUVLO}	REF UVLO ⁽¹⁾	Rising edge of VREF, EN = 'HI'		1.8			V
V _{VREFUHYS}	REF UVLO hysteresis ⁽¹⁾			100			mV
V _{POR5FILT}	Reset	OVP latch is reset by V5FILT falling below the reset threshold		1.5	2.3	3.1	V
VOLTAGE FEEDBACK LOOP: VREF, VOOUT, AND VOLTAGE GM AMPLIFIER							
V _{OUTTOL}	VOOUT accuracy	V _{VOOUT} = 0.8V, No droop		-1.5%	0%	1.5%	
V _{VREF}	VREF	I _{VREF} = 0 μA, T _A = 25°C			2		V
G _M	Transconductance				1		mS
V _{DM}	Differential mode input voltage			0		80	mV
I _{COMP}	COMP pin maximum sourcing current	V _{COMP} = 2 V			-80		μA
V _{OFFSET}	Input offset voltage	T _A = 25°C		-5	0	5	mV
R _{DSCH}	Output voltage discharge resistance				42		Ω
f _{-3dBVL}	-3dB Frequency ⁽¹⁾				6		MHz
CURRENT SENSE: CURRENT SENSE AMPLIFIER, OVER CURRENT AND ZERO CROSSING							
A _{CSINT}	Internal current sense gain	Gain from the current of the low-side FET to PWM comparator when PWM = "OFF"		43	50	57	mV/A
I _{OCL}	Positive overcurrent limit (valley)				6.6		A
I _{OCL(neg)}	Negative overcurrent limit (valley)				-6		A
V _{ZXOFF}	Zero crossing comp internal offset				0		mV
DRIVERS: BOOT STRAP SWITCH							
R _{DSONBST}	Internal BST switch on-resistance	I _{BST} = 10 mA, T _A = 25°C			5	10	Ω
I _{BSTLK}	Internal BST switch leakage current	V _{BST} = 14 V, V _{SW} = 7 V, T _A = 25°C				1	μA

(1) Ensured by design, not production tested.

ELECTRICAL CHARACTERISTICS (continued)

over recommended free-air temperature range, $V_{VIN} = 5.0\text{ V}$, $V_{V5DRV} = V_{V5FILT} = 5\text{ V}$, MODE = OPEN, PGND = GND (unless otherwise noted)

PARAMETER		CONDITIONS	MIN	TYP	MAX	UNIT
PROTECTION: OVP, UVP, PGOOD, and THERMAL SHUTDOWN						
V_{PGDLL}	PGOOD deassert to lower (PGOOD → Low)	Measured at the VOUT pin w/r/t V_{SLEW}	82%	84%	86%	
$V_{PGHYSHL}$	PGOOD high hysteresis			8%		
V_{PGDLH}	PGOOD de-assert to higher (PGOOD → Low)	Measured at the VOUT pin w/r/t V_{SLEW}	114%	116%	118%	
$V_{PGHYSHH}$	PGOOD high hysteresis			-8%		
$V_{INMINPG}$	Minimum VIN voltage for valid PGOOD	Measured at the VIN pin with a 2-mA sink current on PGOOD pin	0.9	1.3	1.5	V
V_{OVP}	OVP threshold	Measured at the VOUT pin w/r/t V_{SLEW}	118%	120%	122%	
V_{UVP}	UVP threshold	Measured at the VOUT pin w/r/t V_{SLEW} , device latches OFF, begins soft-stop	66%	68%	70%	
TH_{SD}	Thermal shutdown ⁽²⁾	Latch off controller, attempt soft-stop.		125		°C
$TH_{SD(hys)}$	Thermal Shutdown hysteresis ⁽²⁾	Controller re-starts after temperature has dropped		10		°C
TIMERS: ON-TIME, MINIMUM OFF TIME, SS, AND I/O TIMINGS						
$t_{ONESHOTC}$	PWM one-shot ⁽²⁾	$V_{VIN} = 5\text{ V}$, $V_{VOUT} = 0.8\text{ V}$, $f_{SW} = 667\text{ kHz}$, fixed VID mode		240		ns
		$V_{VIN} = 5\text{ V}$, $V_{VOUT} = 0.8\text{ V}$, $f_{SW} = 1\text{ MHz}$, fixed VID mode		160		ns
$t_{MIN(off)}$	Minimum OFF time ⁽²⁾	$V_{VIN} = 5\text{ V}$, $V_{VOUT} = 0.8\text{ V}$, $f_{SW} = 1\text{ MHz}$, DRVL on, SW = PGND, $V_{VOUT} < V_{SLEW}$		357		ns
t_{PGDDL}	PGOOD startup delay time ⁽²⁾ (excl. SLEW ramp up time)	Delay starts from VOUT = VID code 00 and excludes SLEW ramp up time		3		ms
$t_{PGDPDLYH}$	PGOOD high propagation delay time ⁽²⁾	50 mV over drive, rising edge	0.8	1	1.2	ms
$t_{PGDPDLYL}$	PGOOD low propagation delay time ⁽²⁾	50 mV over drive, falling edge		10		µs
t_{OVPDLY}	OVP delay time ⁽²⁾	Time from the VOUT pin out of +20% of V_{SLEW} to OVP fault		0.2		µs
$t_{UVDLYEN}$	Undervoltage fault enable delay (excl. SLEW ramp up time) ⁽²⁾	Time from (VOUT = VID code 00) going high to undervoltage fault is ready		3		ms
t_{UVPDLY}	UVP delay time ⁽²⁾	Time from the VOUT pin out of -30% of V_{SLEW} to UVP fault		8.5		µs
I_{SLEW}	Soft-start and voltage transition	$C_{SS} = 10\text{ nF}$ assuming voltage slew rate of 1 mV/µs	9	10	11	µA
LOGIC PINS: I/O VOLTAGE AND CURRENT						
V_{PGDPD}	PGOOD pull down voltage	PGOOD low impedance, $I_{SINK} = 4\text{ mA}$, $V_{VIN} = V_{V5FILT} = 4.5\text{ V}$			0.3	V
I_{PGDLKG}	PGOOD leakage current	PGOOD high impedance, forced to 5.5 V	-1	0	1	µA
V_{ENH}	EN logic high	EN, VCCP logic	0.8			V
V_{ENL}	EN logic low	EN, VCCP logic			0.3	V
I_{EN}	EN input current				1	µA
V_{VIDH}	VID logic high	VID0, VID1	0.8			V
V_{VIDL}	VID logic low	VID0, VID1			0.3	V
V_{MODETH}	MODE threshold voltage ⁽³⁾	MODE 3	0.37	0.42	0.47	V
		MODE 4	0.55	0.60	0.65	
		MODE 7	1.75	1.80	1.85	
I_{MODE}	MODE current			15		µA
R_{PD}	VID pull-down resistance			10		kΩ

(2) Ensured by design, not production tested.

(3) See Table 3 for descriptions of MODE parameters.

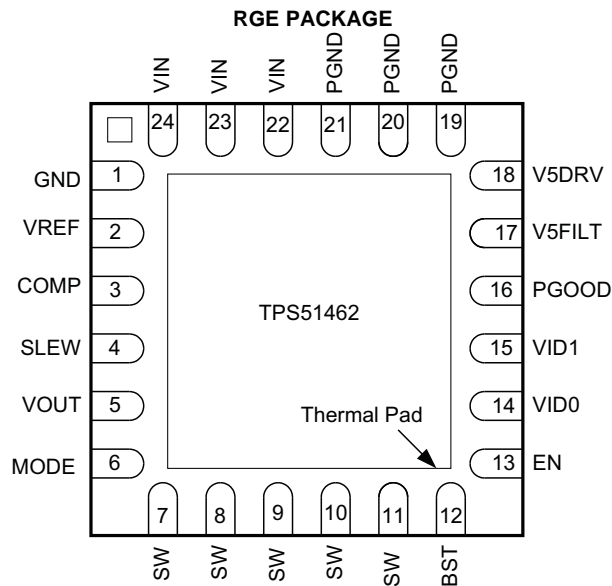

PIN FUNCTIONS

PIN		I/O	DESCRIPTION
NO.	NAME		
19	PGND	I	Power ground. Source terminal of the rectifying low-side power FET.
20			
21			
22	VIN	I	Power supply input pin. Drain terminal of the switching high-side power FET.
23			
24			
1	GND	–	Signal ground.
2	VREF	O	2.0-V reference output. Connect a 0.22- μ F ceramic capacitor to GND.
3	COMP	O	Connect series R-C to the VREF pin for loop compensation.
4	SLEW	I/O	Program the startup and voltage transition time using an external capacitor via 10- μ A current source.
5	VOUT	I	Output voltage monitor input pin.
6	MODE	I	Allows selection of switching frequencies and output voltage. (See Table 3)
7	SW	I/O	Switching node output. Connect to the external inductor.
8			
9			
10			
11			
12	BST	I	Power supply for internal high-side gate driver. Connect a 0.1- μ F bootstrap capacitor between this pin and the SW pin.
13	EN	I	Enable of the SMPS.
14	VID0	I	2-bit VID input.
15	VID1		
16	PGOOD	O	Power good output. Connect pull-up resistor.
17	V5FILT	I	5-V power supply for analog circuits.
18	V5DRV	I	5-V power supply for the gate driver.
	Thermal Pad	–	Connect directly to system GND plane with multiple vias.

BLOCK DIAGRAM

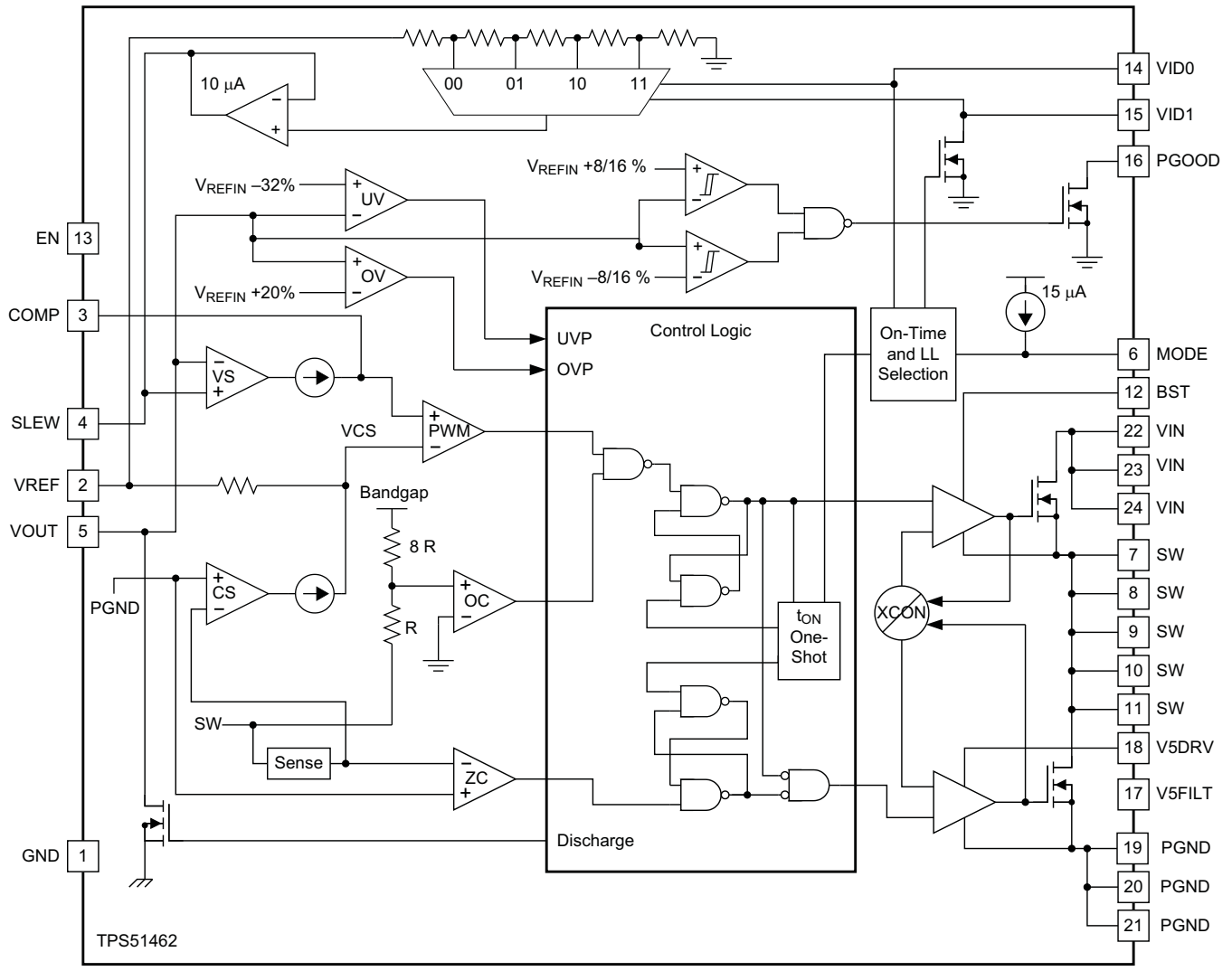

UDG-11209

Table 1. Intel SA VID

VID 0	VID 1	VCCSA
0	0	0.9 V
0	1	0.80 V ⁽¹⁾ MODE = Open
0	1	0.85 V ⁽¹⁾ MODE = 33 kΩ
1	0	0.725 V
1	1	0.675 V

(1) 0.8 V for 2012/2013 SV processors and 0.85 V for 2012 LV/ULV processors.

TPS51462 APPLICATION DIAGRAM

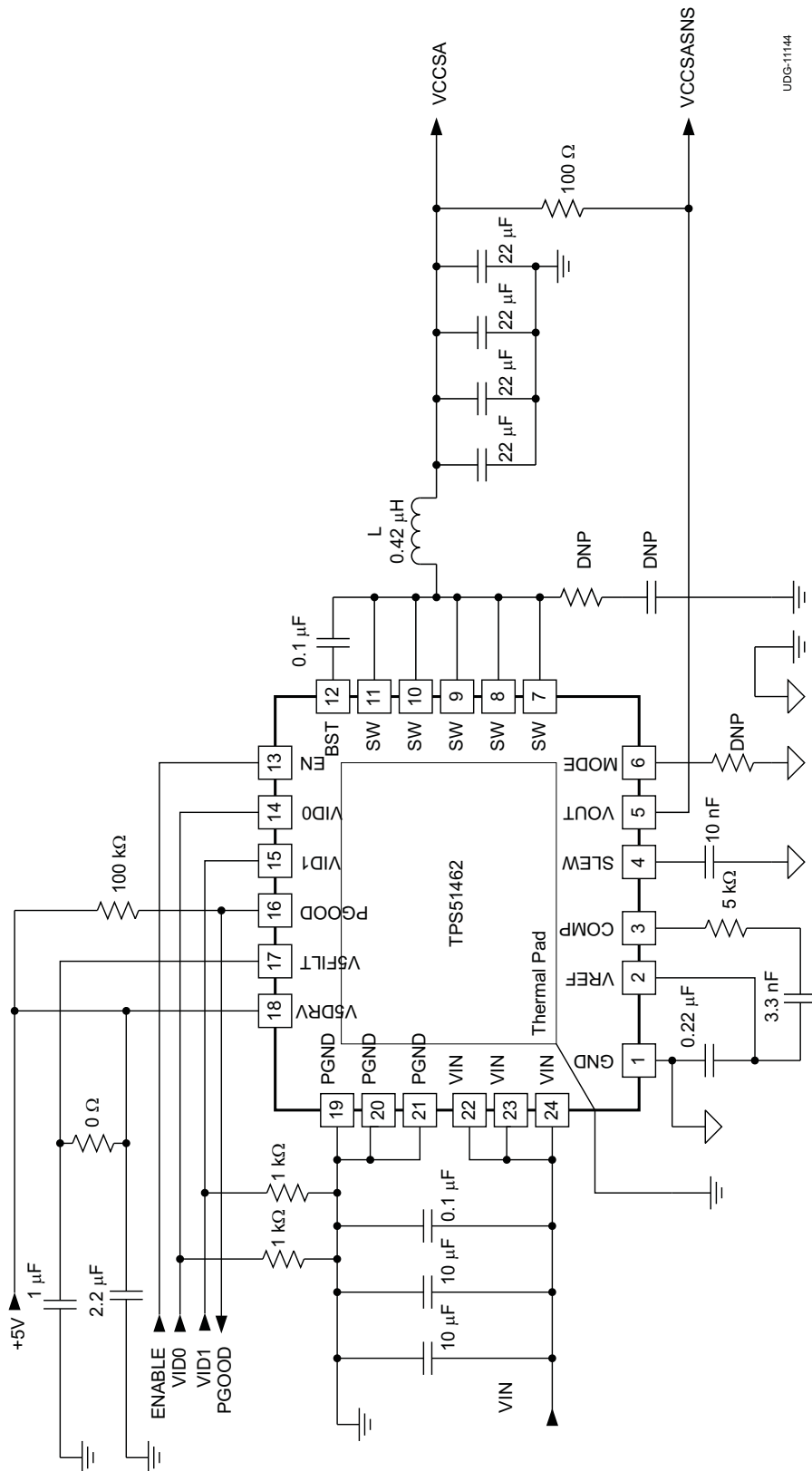

Figure 1. Application Schematic Using Non-Droop Configuration

Application Circuit List of Materials

Recommended part numbers for key external components for the circuit in [Figure 1](#) are listed in [Table 2](#).

**Table 2. Key External Component Recommendations
([Figure 1](#))**

FUNCTION	MANUFACTURER	PART NUMBER
Output Inductor	Nec-Tokin	MPCG0740LR42C
Ceramic Output Capacitors	Panasonic	ECJ2FB0J226M
	Murata	GRM21BR60J226ME39L

APPLICATION INFORMATION

Functional Overview

The TPS51462 is a D-CAP+™ mode adaptive on-time converter. The output voltage is set using a 2-bit DAC that outputs a reference voltage in accordance with the code defined in Table 1. *VID-on-the-fly* transitions are supported with the slew rate controlled by a single capacitor on the SLEW pin. The converter automatically runs in discontinuous conduction mode (DCM) to optimize light-load efficiency. Two switching frequency selections are provided, (700 kHz and 1 MHz) to enable optimization of the power chain for the cost, size and efficiency requirements of the design.

In adaptive on-time converters, the controller varies the on-time as a function of input and output voltage to maintain a nearly constant frequency during steady-state conditions. In conventional constant on-time converters, each cycle begins when the output voltage crosses to a fixed reference level. However, in the TPS51462, the cycle begins when the current feedback reaches an error voltage level which is the amplified difference between the reference voltage and the feedback voltage.

PWM Operation

Referring to Figure 2, in steady state, continuous conduction mode, the converter operates in the following way.

Starting with the condition that the top FET is off and the bottom FET is on, the current feedback (V_{CS}) is higher than the error amplifier output (V_{COMP}). V_{CS} falls until it hits V_{COMP} , which contains a component of the output ripple voltage. V_{CS} is not directly accessible by measuring signals on pins of TPS51462. The PWM comparator senses where the two waveforms cross and triggers the on-time generator.

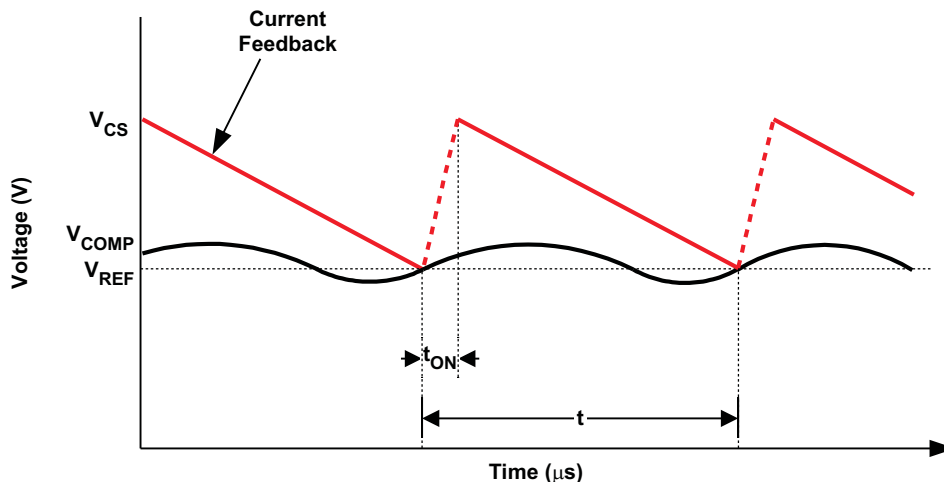

UDG-10187

Figure 2. D-CAP+™ Mode Basic Waveforms

The current feedback is an amplified and filtered version of the voltage between PGND and SW during low-side FET on-time. The TPS51462 also provides a single-ended differential voltage (V_{OUT}) feedback to increase the system accuracy and reduce the dependence of circuit performance on layout.

PWM Frequency and Adaptive on Time Control

In general, the on-time (at the SW node) can be estimated by Equation 1.

$$t_{ON} = \frac{V_{OUT}}{V_{IN}} \times \frac{1}{f_{SW}}$$

where

- f_{SW} is the frequency selected by the connection of the MODE pin (1)

The on-time pulse is sent to the top FET. The inductor current and the current feedback rises to peak value. Each ON pulse is latched to prevent double pulsing. Switching frequency settings are shown in Table 3.

Non-Droop Configuration

The TPS51462 offers a non-droop solution only. The benefit of a non-droop approach is that load regulation is flat, therefore, in a system where tight DC tolerance is desired, the non-droop approach is recommended. For the Intel system agent application, non-droop is recommended as the standard configuration.

The non-droop approach can be implemented by connecting a resistor and a capacitor between the COMP and the VREF pins. The purpose of the type II compensation is to obtain high DC feedback gain while minimizing the phase delay at unity gain cross over frequency of the converter.

The value of the resistor (R_C) can be calculated using the desired unity gain bandwidth of the converter, and the value of the capacitor (C_C) can be calculated by knowing where the zero location is desired. An application tool that calculates these values is available from your local TI Field Application Engineer.

Figure 3 shows the basic implementation of the non-droop mode using the TPS51462.

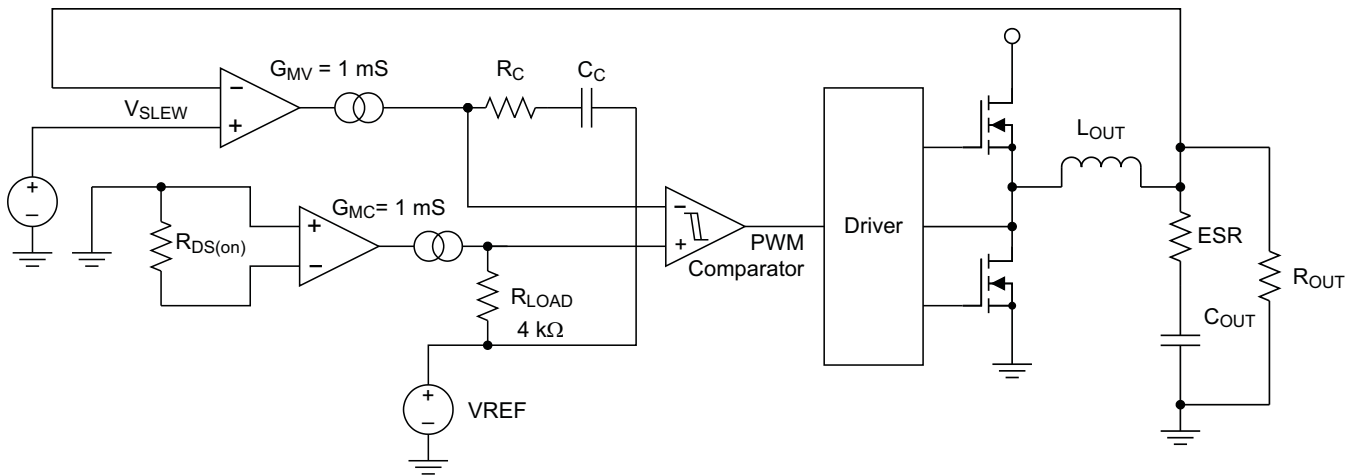

UDG-11208

Figure 3. Non-Droop Mode Basic Implementation

Figure 4 shows the load regulation of the system agent rail using non-droop configuration.

Figure 5 shows the transient response of TPS51462 using non-droop configuration where $C_{OUT} = 4 \times 22 \mu\text{F}$. The applied step load is from 0 A to 2 A.

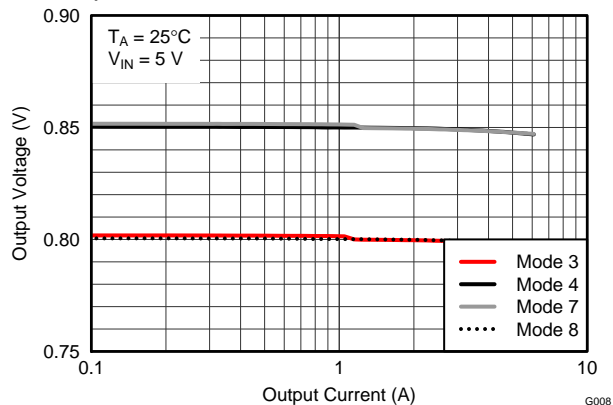

Figure 4. 0.8 V/0.85 V Load Regulation ($V_{IN} = 5 \text{ V}$) Non-Droop Configuration

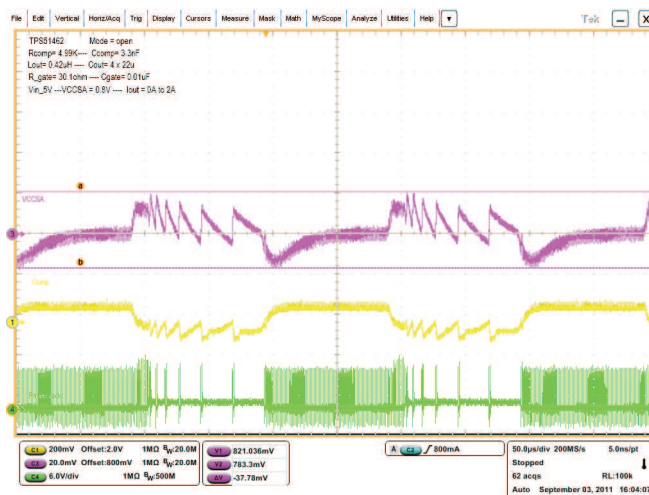

Figure 5. Non-Droop Configuration Transient Response

Table 3. Mode Parameter Table

MODE	MODE CONNECTION	SWITCHING FREQUENCY (f_{sw})	VID1 = 1 VID0 = 0 (V)
3	22 k Ω	700 kHz	0.80
4	33 k Ω	1 MHz	0.85
7	100 k Ω	700 kHz	0.85
8	Open	1 MHz	0.80

Light Load Power Saving Features

The TPS51462 has an automatic pulse-skipping mode to provide excellent efficiency over a wide load range. The converter senses inductor current and prevents negative flow by shutting off the low-side gate driver. This saves power by eliminating re-circulation of the inductor current. Further, when the bottom FET shuts off, the converter enters discontinuous mode, and the switching frequency decreases, thus reducing switching losses as well.

Voltage Slewing

The TPS51462 ramps the SLEW voltage up and down to perform the output voltage transitioning. The timing is independent of switching frequency, as well as output resistive and capacitive loading. It is set by a capacitor from SLEW pin to GND, called C_{SLEW} , together with an internal current source of 10 μ A. The slew rate is used to set the startup and voltage transition rate.

$$C_{SLEW} = \frac{I_{SLEW}}{SR} \quad (2)$$

$$t_{SS} = \frac{C_{SLEW} \times 0.9V}{I_{SLEW}}$$

where

- $I_{SLEW} = 10 \mu$ A (nom)
- SR is the target output voltage slew rate, per Intel specification between 0.5 mV/ μ s and 10 mV/ μ s (3)

For the current reference design, an SR of 1 mV/ μ s is targeted. The C_{SLEW} is calculated to be 10 nF. The slower slew rate is desired to minimize large inductor current perturbation during startup and voltage transitioning thus reducing the possibility of acoustic noise.

After the power up, when VID1 is transitioning from 0 to 1, TPS51462 follows the SLEW voltage entering the forced PWM mode to actively discharge the output voltage from 0.9 V to 0.8 V. The actual output voltage slew rate is approximately the same as the set slew rate while the bandwidth of the converter supports it and there is no overcurrent triggered by additional charging current flowing into the output capacitors. After SLEW transition is completed, PWM mode is maintained for 64 μ s (16 clock cycles when the frequency is 1 MHz) to ensure voltage regulation.

Protection Features

The TPS51462 offers many features to protect the converter power chain as well as the system electronics.

5-V Undervoltage Protection (UVLO)

The TPS51462 continuously monitors the voltage on the V5FILT pin to ensure that the voltage level is high enough to bias the device properly and to provide sufficient gate drive potential to maintain high efficiency. The converter starts with approximately 4.3 V and has a nominal of 440 mV of hysteresis. If the 5-V UVLO limit is reached, the converter transitions the phase node into a 3-state function. And the converter remains in the off state until the device is reset by cycling 5 V until the 5-V POR is reached (2.3-V nominal). The power input does not have an UVLO function

Power Good Signals

The TPS51462 has one open-drain *power good* (PGOOD) pin. During startup, there is a 3 ms power good delay starting from the output voltage reaching the regulation point (excluding soft-start ramp-up time). And there is also a 1 ms power good high propagation delay. The PGOOD pin de-asserts as soon as the EN pin is pulled low or an undervoltage condition on V5FILT is detected. The PGOOD signal is blanked during VID voltage transitions to prevent false triggering during voltage slewing.

Output Overvoltage Protection (OVP)

In addition to the power good function described above, the TPS51462 has additional OVP and UVP thresholds and protection circuits.

An OVP condition is detected when the output voltage is approximately $120\% \times V_{SLEW}$. In this case, the converter de-asserts the PGOOD signals and performs the overvoltage protection function. The converter remains in this state until the device is reset by cycling 5 V until the 5-V POR threshold (2.3 V nominal) is reached.

Output Undervoltage Protection (UVP)

Output undervoltage protection works in conjunction with the current protection described in the [Overcurrent Protection](#) and [Overcurrent Limit](#) sections. If the output voltage drops below 70% of V_{SLEW} , after an 8- μ s delay, the device latches OFF. Undervoltage protection can be reset only by EN or a 5-V POR.

Overcurrent Protection

Both positive and negative overcurrent protection are provided in the TPS51462:

- Overcurrent Limit (OCL)
- Negative OCL (level same as positive OCL)

Overcurrent Limit

If the sensed current value is above the OCL setting, the converter delays the next ON pulse until the current drops below the OCL limit. Current limiting occurs on a pulse-by-pulse basis. The TPS51462 uses a valley current limiting scheme where the DC OCL trip point is the OCL limit plus half of the inductor ripple current. The minimum valley OCL is 6 A over process and temperature.

During the overcurrent protection event, the output voltage likely droops until the UVP limit is reached. Then, the converter de-asserts the PGOOD pin, and then latches OFF after an 8- μ s delay. The converter remains in this state until the device is reset by EN or a 5VFILT POR.

$$I_{OCL(dc)} = I_{OCL(valley)} + \frac{1}{2} \times I_{P-P} \quad (4)$$

Negative OCL

The negative OCL circuit acts when the converter is sinking current from the output capacitor(s). The converter continues to act in a *valley* mode, the absolute value of the negative OCL set point is typically -6.5 A.

Thermal Protection

Thermal Shutdown

The TPS51462 has an internal temperature sensor. When the temperature reaches a nominal 125°C, the device shuts down until the temperature cools by approximately 10°C. Then the converter restarts.

Startup and VID Transition Timing Diagrams

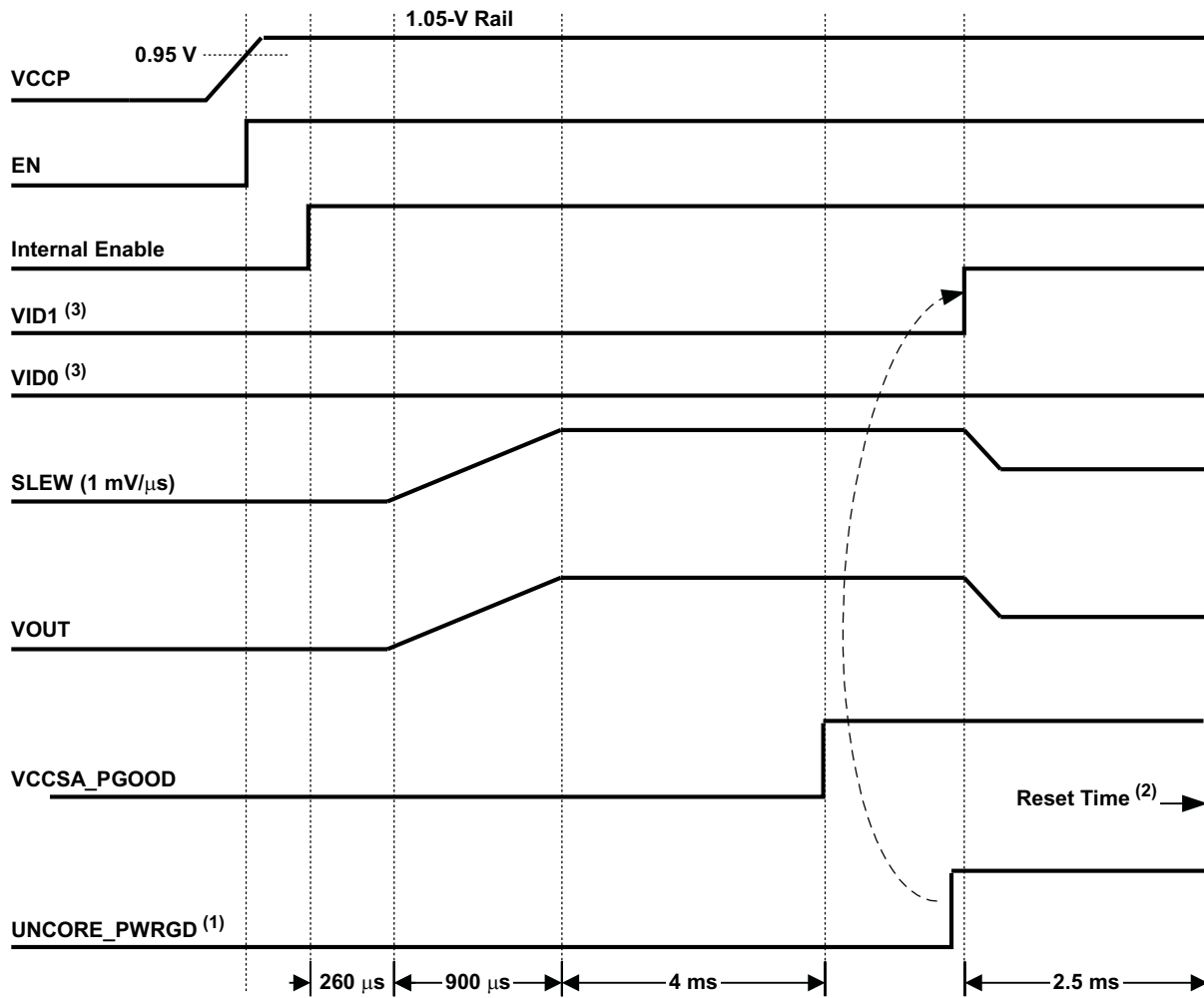

UDG-10191

Figure 6. Fixed VID/Fixed Step Startup and VID Toggle Timing Diagram for 2011 Intel Platform

For Figure 6:

- (1) Includes VCCA, VCCAXG, and VDDQ power rails.
- (2) Processor reset: VID transition must be completed by this time.
- (3) 1-kΩ pull-down resistor required.

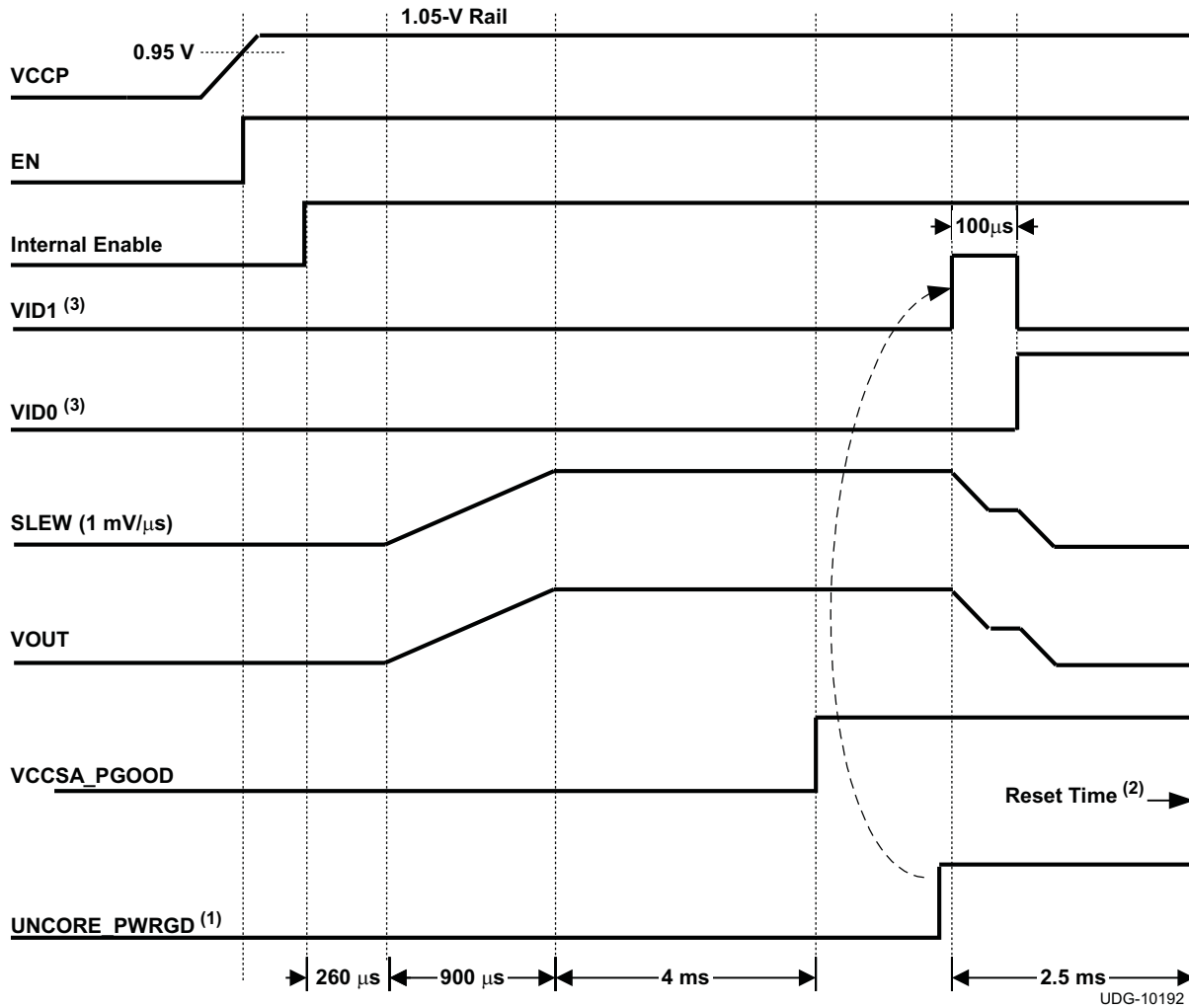

Figure 7. Fixed VID/Fixed Step Startup and VID Toggle Timing Diagram for 2012 Intel Platform

For Figure 7:

- (1) Includes VCCA, VCCAXG, and VDDQ power rails.
- (2) Processor reset: VID transition must be completed by this time.
- (3) 1-kΩ pull-down resistor required.

TYPICAL CHARACTERISTICS

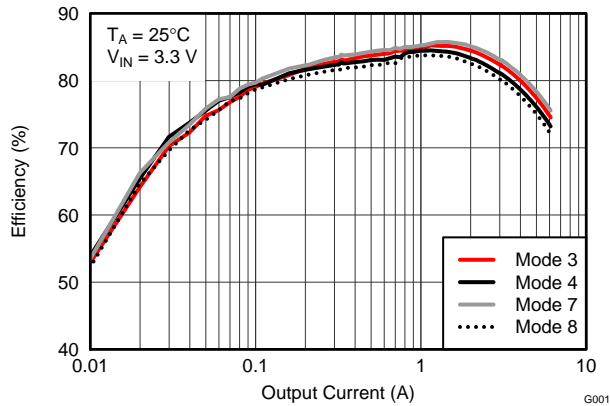

Figure 8. Efficiency vs. Output Current

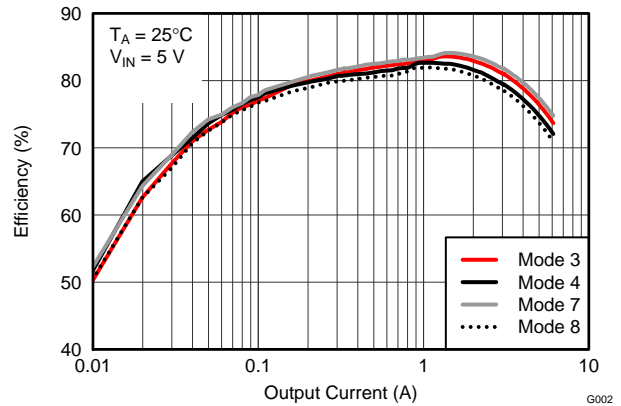

Figure 9. Efficiency vs. Output Current

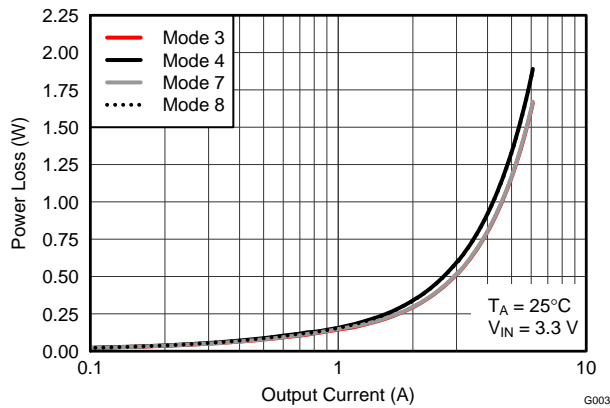

Figure 10. Power Loss vs. Output Current

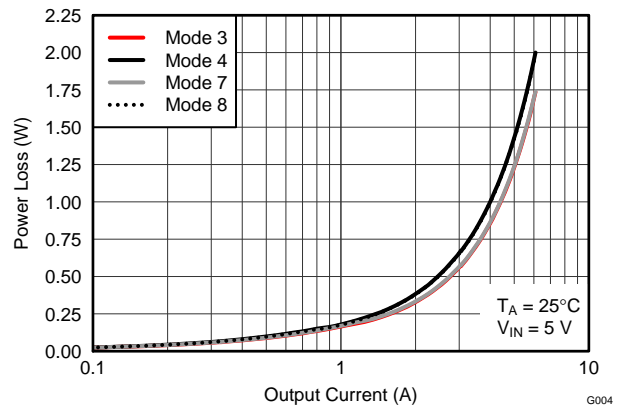

Figure 11. Power Loss vs. Output Current

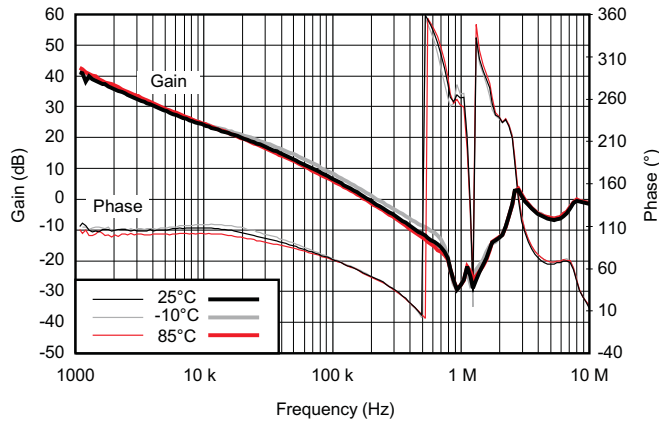

Figure 12. Bode Plot, Non-Droop Mode

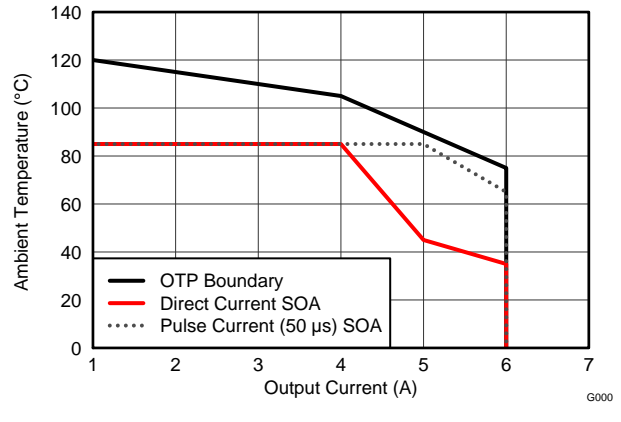

Figure 13. Safe Operating Area

TYPICAL CHARACTERISTICS (continued)

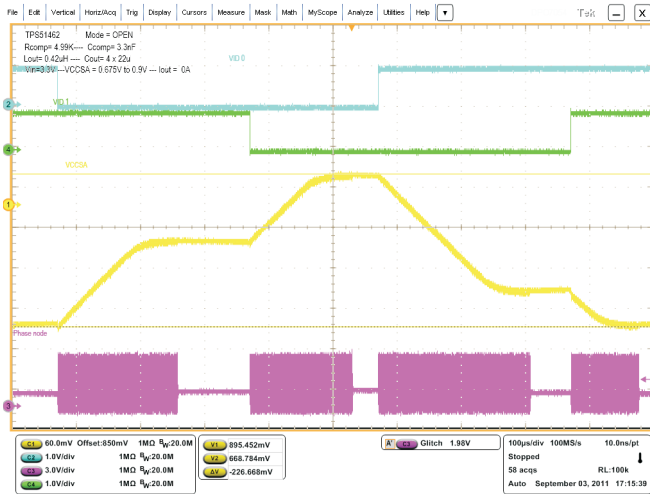

Figure 14. Mode=8, I_{OUT} = 0 A, VID Transitions



Figure 15. Mode=8, I_{OUT} = 3 A, VID Transitions

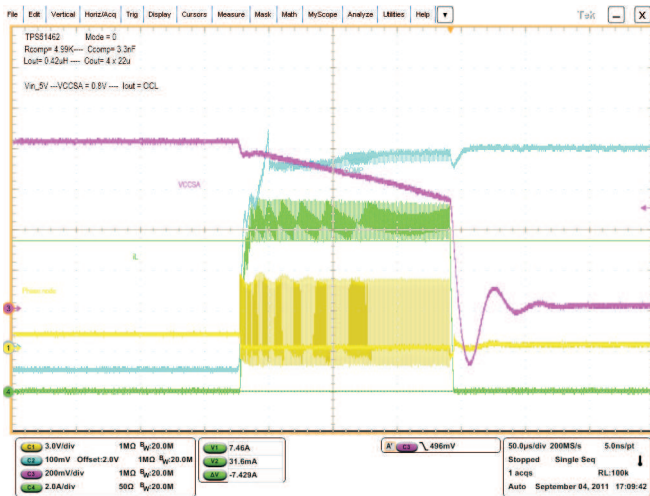

Figure 16. Mode = 8, OCL

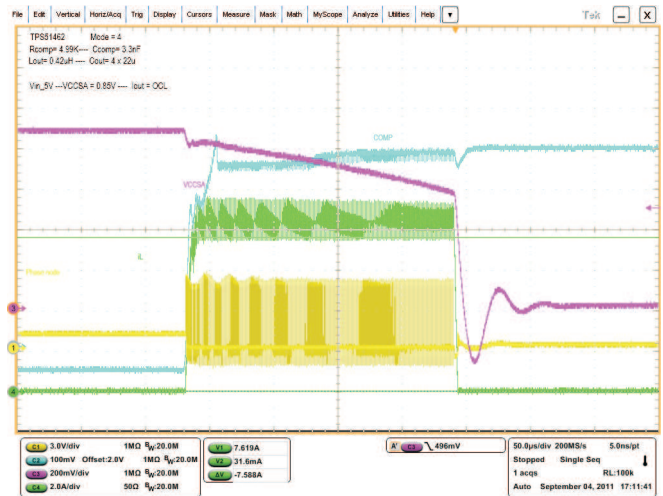

Figure 17. Mode=4, OCL

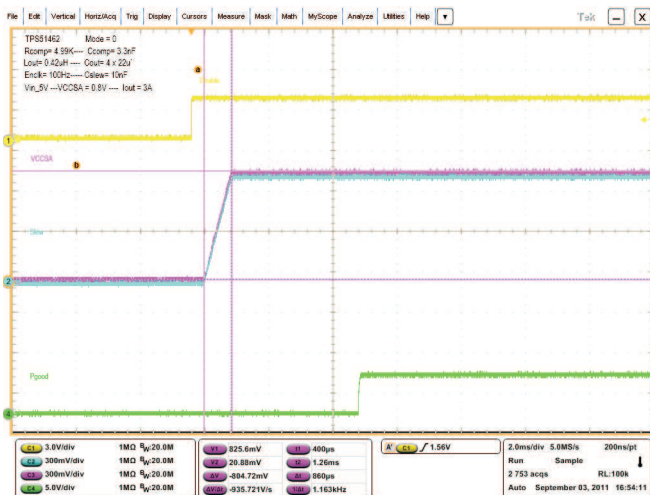

Figure 18. Mode= 8, I_{OUT} = 3 A, Soft-Start

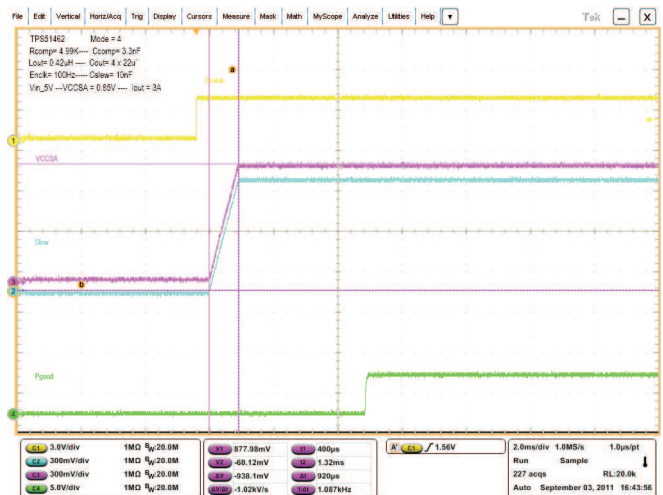

Figure 19. Mode= 4, I_{OUT} = 3 A, Soft-Start

DESIGN PROCEDURE

The simplified design procedure is done for a non-droop application using the TPS51462 converter.

Step One

Determine the specifications.

The System Agent Rail requirements provide the following key parameters:

1. $V_{00} = 0.90 \text{ V}$
2. $V_{10} = 0.80 \text{ V}$
3. $I_{CC(\text{max})} = 6 \text{ A}$
4. $I_{DYN(\text{max})} = 2 \text{ A}$
5. $I_{CC(\text{tdc})} = 3 \text{ A}$

Step Two

Determine system parameters.

The input voltage range and operating frequency are of primary interest. For example:

1. $V_{IN} = 5 \text{ V}$
2. $f_{SW} = 1 \text{ MHz}$

Step Three

Determine inductor value and choose inductor.

Smaller values of inductor have better transient performance but higher ripple and lower efficiency. Higher values have the opposite characteristics. It is common practice to limit the ripple current to 25% to 50% of the maximum current. In this case, use 25%:

$$I_{P-P} = 6 \text{ A} \times 0.25 = 1.5 \text{ A} \quad (5)$$

At $f_{SW} = 1 \text{ MHz}$, with a 5-V input and a 0.80-V output:

$$L = \frac{V \times dT}{I_{P-P}} = \frac{(V_{IN} - V_{10}) \times \left(\frac{V_{10}}{f_{SW} \times V_{IN}} \right)}{I_{P-P}} = \frac{(5 - 0.8) \times \left(\frac{0.8}{(1 \times 5)} \right)}{1.5 \text{ A}} = 0.45 \mu\text{H} \quad (6)$$

For this application, a 0.42- μH , 1.55-m Ω inductor from NEC-TOKIN with part number MPCG0740LR42C is chosen.

Step Four

Set the output voltage.

The output voltage is determined by the VID settings. The actual voltage set point for each VID setting is listed in [Table 1](#). No external resistor dividers are needed for this design.

Step Five

Calculate C_{SLEW} .

VID pin transition and soft-start time is determined by C_{SLEW} and 10 μA of internal current source.

$$C_{SLEW} = \frac{I_{SLEW}}{SR_{DAC}} = \frac{10 \mu\text{A}}{1 \text{ mV} / \mu\text{s}} = 10 \text{ nF} \quad (7)$$

The slower slew rate is desired to minimize large inductor current perturbation during startup and voltage transition, thus reducing the possibility of acoustic noise.

Given the C_{SLEW} , use [Equation 8](#) to calculate the soft start time.

$$t_{SS} = \frac{C_{SLEW} \times 0.9V}{I_{SLEW}} = \frac{10nF \times 0.9V}{10\mu A} = 900 \mu s \quad (8)$$

Step Six

Calculate OCL.

The DC OCL level of TPS51462 design is determined by [Equation 9](#),

$$I_{OCL(dc)} = I_{OCL(valley)} + \frac{1}{2} \times I_{P-P} = 6A + \frac{1}{2} \times 1.5A = 6.75A \quad (9)$$

The minimum valley OCL is 6 A over process and temperature, and $I_{P-P} = 1.5 A$, the minimum DC OCL is calculated to be 6.75A.

Step Seven

Determine the output capacitance.

To determine C_{OUT} based on transient and stability requirement, first calculate the the minimum output capacitance for a given transient.

[Equation 11](#) and [Equation 10](#) can be used to estimate the amount of capacitance needed for a given dynamic load step/release. Please note that there are other factors that may impact the amount of output capacitance for a specific design, such as ripple and stability. [Equation 11](#) and [Equation 10](#) are used only to estimate the transient requirement, the result should be used in conjunction with other factors of the design to determine the necessary output capacitance for the application.

$$C_{OUT(min_under)} = \frac{L \times \Delta I_{LOAD(max)}^2 \times \left(\frac{V_{VOUT} \times t_{SW}}{V_{IN(min)}} + t_{MIN(off)} \right)}{2 \times \Delta V_{LOAD(insert)} \times \left(\left(\frac{V_{IN(min)} - V_{VOUT}}{V_{IN(min)}} \right) \times t_{SW} - t_{MIN(off)} \right) \times V_{VOUT}} \quad (10)$$

$$C_{OUT(min_over)} = \frac{L_{OUT} \times \left(\Delta I_{LOAD(max)} \right)^2}{2 \times \Delta V_{LOAD(release)} \times V_{VOUT}} \quad (11)$$

[Equation 10](#) and [Equation 11](#) calculate the minimum C_{OUT} for meeting the transient requirement, which is 72.9 μF assuming the following:

- $\pm 3\%$ voltage allowance for load step and release
- MLCC capacitance derating of 60% due to DC and AC bias effect

In this reference design, 4, 22- μF capacitors are used in order to provide this amount of capacitance.

Step Eight

Determine the stability based on the output capacitance C_{OUT} .

In order to achieve stable operation. The 0-dB frequency, f_0 should be kept less than 1/5 of the switching frequency (1 MHz). (See [Figure 3](#))

$$f_0 = \frac{1}{2\pi} \times \frac{G_M}{C_{OUT}} \times \frac{R_C}{R_S} = 150 \text{ kHz}$$

where

$$\bullet \quad R_S = R_{DS(on)} \times G_{MC} \times R_{LOAD} \quad (12)$$

$$R_C = \frac{f_0 \times R_S \times 2\pi \times C_{OUT}}{G_M} = \frac{150 \text{ kHz} \times 53 \text{ m}\Omega \times 2\pi \times 88 \mu\text{F}}{1 \text{ mS}} \approx 5 \text{ k}\Omega \quad (13)$$

Using 4, 22- μF capacitors, the compensation resistance, R_C can be calculated to be approximately 5 k Ω .

The purpose of the comparator capacitor (C_C) is to reduce the DC component to obtain high DC feedback gain. However, as it causes phase delay, another zero to cancel this effect at f_0 is needed. This zero can be determined by values of C_C and the compensation resistor, R_C .

$$f_z = \frac{1}{2\pi \times R_C \times C_C} = \frac{f_0}{10} \quad (14)$$

And since R_C has previously been derived, the value of C_C is calculated to be 2.2 nF. In order to further boost phase margin, a value of 3.3-nF is chosen for this reference design.

Step Nine

Select decoupling and peripheral components.

For TPS51462 peripheral capacitors use the following minimum values of ceramic capacitance. X5R or better temperature coefficient is recommended. Tighter tolerances and higher voltage ratings are always appropriate.

- V5DRV decoupling $\geq 2.2 \mu\text{F}$, $\geq 10 \text{ V}$
- V5FILT decoupling $\geq 1 \mu\text{F}$, $\geq 10 \text{ V}$
- VREF decoupling 0.22 μF to 1 μF , $\geq 4 \text{ V}$
- Bootstrap capacitors $\geq 0.1 \mu\text{F}$, $\geq 10 \text{ V}$
- Pull-up resistors on PGOOD, 100 k Ω

Layout Considerations

Good layout is essential for stable power supply operation. Follow these guidelines for an efficient PCB layout.

- Connect PGND pins (or at least one of the pins) to the thermal PAD underneath the device. Also connect GND pin to the thermal PAD underneath the device. Use four vias to connect the thermal pad to internal ground planes.
- Place VIN, V5DRV, V5FILT and 2VREF decoupling capacitors as close to the device as possible.
- Use wide traces for the VIN, VOUT, PGND and SW pins. These nodes carry high current and also serve as heat sinks.
- Place feedback and compensation components as close to the device as possible.
- Keep analog signals (SLEW, COMP) away from noisy signals (SW, VBST).

PACKAGING INFORMATION

Orderable part number	Status (1)	Material type (2)	Package Pins	Package qty Carrier	RoHS (3)	Lead finish/ Ball material (4)	MSL rating/ Peak reflow (5)	Op temp (°C)	Part marking (6)
FX006	Active	Production	VQFN (RGE) 24	3000 LARGE T&R	Yes	NIPDAU	Level-2-260C-1 YEAR	-40 to 85	TPS 51462
TPS51462RGER	Active	Production	VQFN (RGE) 24	3000 LARGE T&R	Yes	NIPDAU	Level-2-260C-1 YEAR	-40 to 85	TPS 51462
TPS51462RGER.A	Active	Production	VQFN (RGE) 24	3000 LARGE T&R	Yes	NIPDAU	Level-2-260C-1 YEAR	-40 to 85	TPS 51462
TPS51462RGET	Active	Production	VQFN (RGE) 24	250 SMALL T&R	Yes	NIPDAU	Level-2-260C-1 YEAR	-40 to 85	TPS 51462
TPS51462RGET.A	Active	Production	VQFN (RGE) 24	250 SMALL T&R	Yes	NIPDAU	Level-2-260C-1 YEAR	-40 to 85	TPS 51462

(1) **Status:** For more details on status, see our [product life cycle](#).

(2) **Material type:** When designated, preproduction parts are prototypes/experimental devices, and are not yet approved or released for full production. Testing and final process, including without limitation quality assurance, reliability performance testing, and/or process qualification, may not yet be complete, and this item is subject to further changes or possible discontinuation. If available for ordering, purchases will be subject to an additional waiver at checkout, and are intended for early internal evaluation purposes only. These items are sold without warranties of any kind.

(3) **RoHS values:** Yes, No, RoHS Exempt. See the [TI RoHS Statement](#) for additional information and value definition.

(4) **Lead finish/Ball material:** Parts may have multiple material finish options. Finish options are separated by a vertical ruled line. Lead finish/Ball material values may wrap to two lines if the finish value exceeds the maximum column width.

(5) **MSL rating/Peak reflow:** The moisture sensitivity level ratings and peak solder (reflow) temperatures. In the event that a part has multiple moisture sensitivity ratings, only the lowest level per JEDEC standards is shown. Refer to the shipping label for the actual reflow temperature that will be used to mount the part to the printed circuit board.

(6) **Part marking:** There may be an additional marking, which relates to the logo, the lot trace code information, or the environmental category of the part.

Multiple part markings will be inside parentheses. Only one part marking contained in parentheses and separated by a "~" will appear on a part. If a line is indented then it is a continuation of the previous line and the two combined represent the entire part marking for that device.

Important Information and Disclaimer: The information provided on this page represents TI's knowledge and belief as of the date that it is provided. TI bases its knowledge and belief on information provided by third parties, and makes no representation or warranty as to the accuracy of such information. Efforts are underway to better integrate information from third parties. TI has taken and continues to take reasonable steps to provide representative and accurate information but may not have conducted destructive testing or chemical analysis on incoming materials and chemicals. TI and TI suppliers consider certain information to be proprietary, and thus CAS numbers and other limited information may not be available for release.

In no event shall TI's liability arising out of such information exceed the total purchase price of the TI part(s) at issue in this document sold by TI to Customer on an annual basis.

TAPE AND REEL INFORMATION

QUADRANT ASSIGNMENTS FOR PIN 1 ORIENTATION IN TAPE

*All dimensions are nominal

Device	Package Type	Package Drawing	Pins	SPQ	Reel Diameter (mm)	Reel Width W1 (mm)	A0 (mm)	B0 (mm)	K0 (mm)	P1 (mm)	W (mm)	Pin1 Quadrant
TPS51462RGER	VQFN	RGE	24	3000	330.0	12.4	4.35	4.35	1.1	8.0	12.0	Q2
TPS51462RGER	VQFN	RGE	24	3000	330.0	12.4	4.25	4.25	1.15	8.0	12.0	Q2
TPS51462RGET	VQFN	RGE	24	250	180.0	12.4	4.25	4.25	1.15	8.0	12.0	Q2
TPS51462RGET	VQFN	RGE	24	250	180.0	12.5	4.35	4.35	1.1	8.0	12.0	Q2

TAPE AND REEL BOX DIMENSIONS



*All dimensions are nominal

Device	Package Type	Package Drawing	Pins	SPQ	Length (mm)	Width (mm)	Height (mm)
TPS51462RGER	VQFN	RGE	24	3000	338.0	355.0	35.0
TPS51462RGER	VQFN	RGE	24	3000	346.0	346.0	33.0
TPS51462RGET	VQFN	RGE	24	250	210.0	185.0	35.0
TPS51462RGET	VQFN	RGE	24	250	338.0	355.0	35.0

RGE 24

GENERIC PACKAGE VIEW

VQFN - 1 mm max height

PLASTIC QUAD FLATPACK - NO LEAD

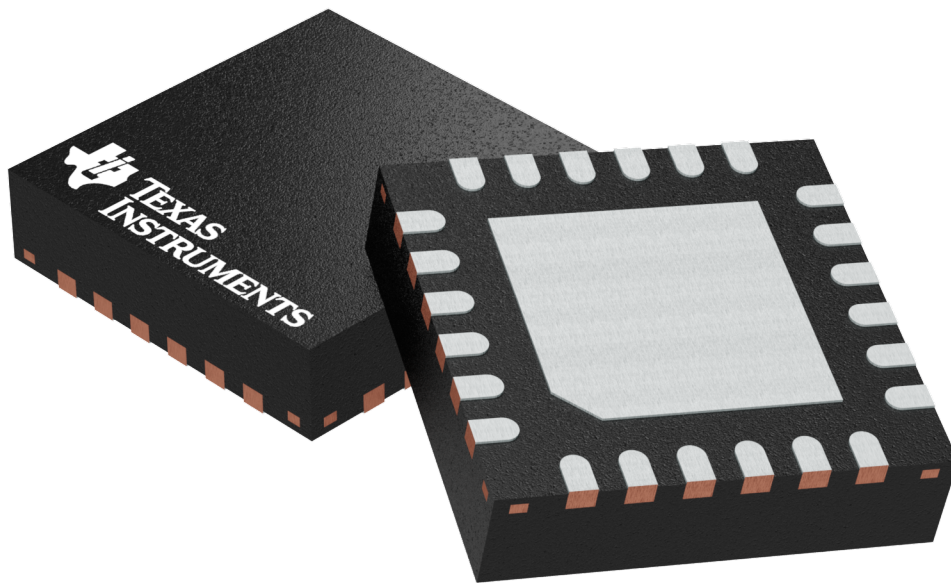

Images above are just a representation of the package family, actual package may vary.
Refer to the product data sheet for package details.

4204104/H

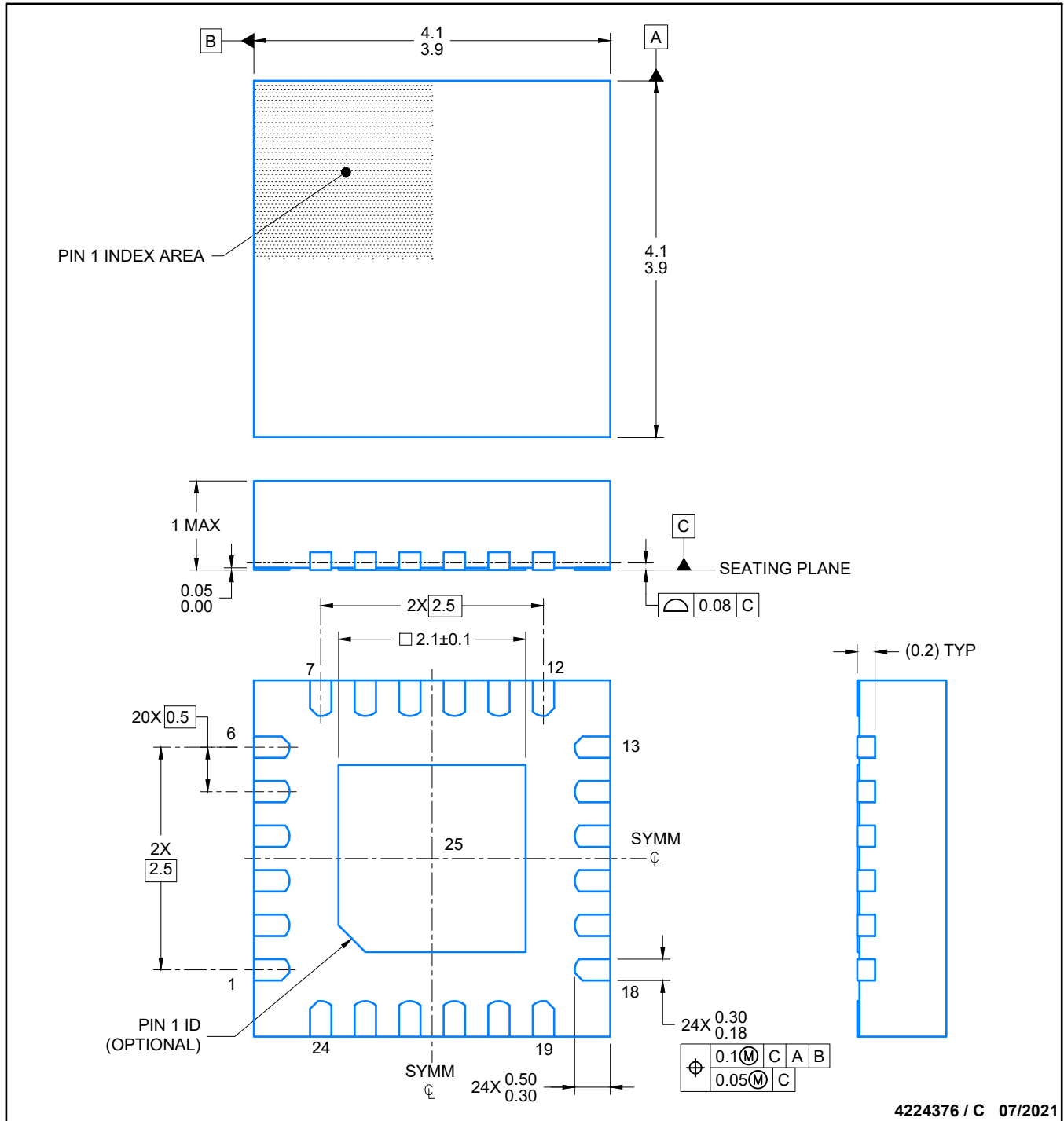

NOTES:

1. All linear dimensions are in millimeters. Any dimensions in parenthesis are for reference only. Dimensioning and tolerancing per ASME Y14.5M.
2. This drawing is subject to change without notice.
3. The package thermal pad must be soldered to the printed circuit board for thermal and mechanical performance.

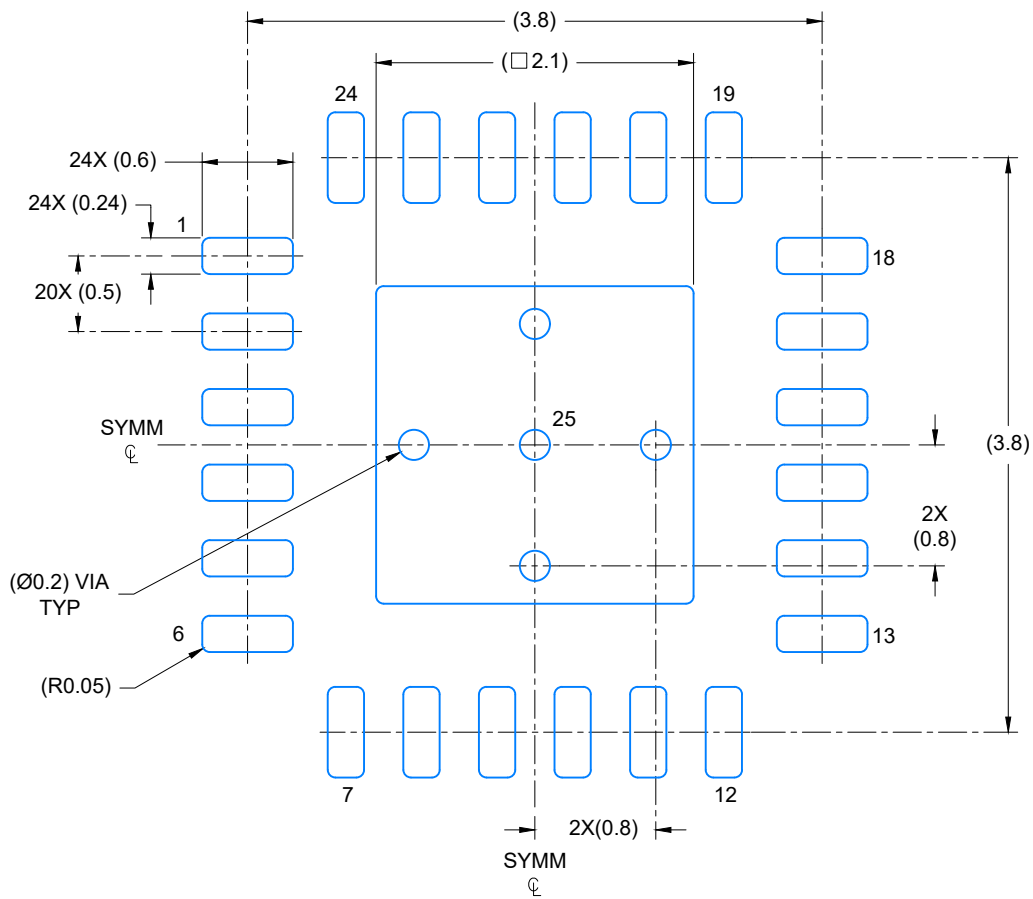

LAND PATTERN EXAMPLE
SCALE: 20X

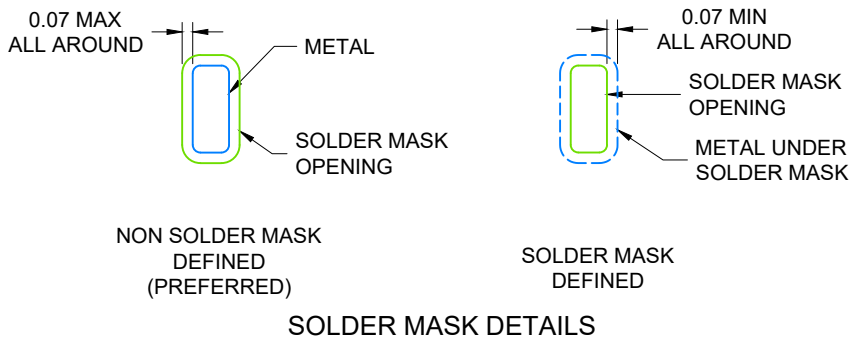

4224376 / C 06/2021

NOTES: (continued)

4. This package is designed to be soldered to a thermal pad on the board. For more information, see Texas Instruments literature number SLUA271 (www.ti.com/lit/slua271).
5. Solder mask tolerances between and around signal pads can vary based on board fabrication site.

EXAMPLE STENCIL DESIGN

RGE0024C

VQFN - 1 mm max height

PLASTIC QUAD FLATPACK- NO LEAD

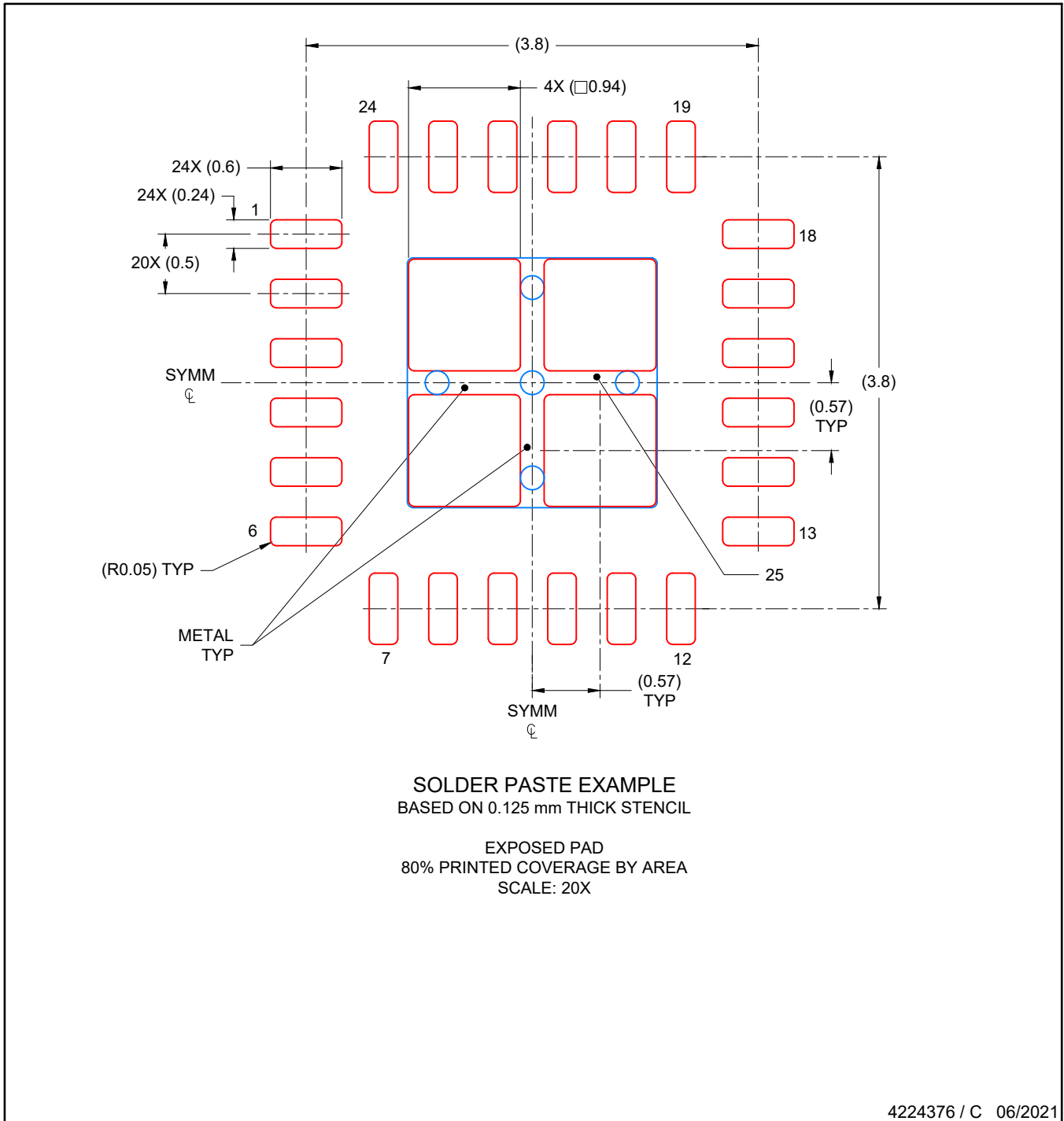

NOTES: (continued)

6. Laser cutting apertures with trapezoidal walls and rounded corners may offer better paste release. IPC-7525 may have alternate design recommendations..

IMPORTANT NOTICE AND DISCLAIMER

TI PROVIDES TECHNICAL AND RELIABILITY DATA (INCLUDING DATASHEETS), DESIGN RESOURCES (INCLUDING REFERENCE DESIGNS), APPLICATION OR OTHER DESIGN ADVICE, WEB TOOLS, SAFETY INFORMATION, AND OTHER RESOURCES "AS IS" AND WITH ALL FAULTS, AND DISCLAIMS ALL WARRANTIES, EXPRESS AND IMPLIED, INCLUDING WITHOUT LIMITATION ANY IMPLIED WARRANTIES OF MERCHANTABILITY, FITNESS FOR A PARTICULAR PURPOSE OR NON-INFRINGEMENT OF THIRD PARTY INTELLECTUAL PROPERTY RIGHTS.

These resources are intended for skilled developers designing with TI products. You are solely responsible for (1) selecting the appropriate TI products for your application, (2) designing, validating and testing your application, and (3) ensuring your application meets applicable standards, and any other safety, security, regulatory or other requirements.

These resources are subject to change without notice. TI grants you permission to use these resources only for development of an application that uses the TI products described in the resource. Other reproduction and display of these resources is prohibited. No license is granted to any other TI intellectual property right or to any third party intellectual property right. TI disclaims responsibility for, and you fully indemnify TI and its representatives against any claims, damages, costs, losses, and liabilities arising out of your use of these resources.

TI's products are provided subject to [TI's Terms of Sale](#), [TI's General Quality Guidelines](#), or other applicable terms available either on ti.com or provided in conjunction with such TI products. TI's provision of these resources does not expand or otherwise alter TI's applicable warranties or warranty disclaimers for TI products. Unless TI explicitly designates a product as custom or customer-specified, TI products are standard, catalog, general purpose devices.

TI objects to and rejects any additional or different terms you may propose.

Copyright © 2026, Texas Instruments Incorporated

Last updated 10/2025