

TVS5200 52V Flat-Clamp Surge Protection Device

1 Features

- IEC 61000-4-5 Surge Protection:
 - 30A (8/20 μ s)
 - Clamping voltage: 58.9V typical at 20A (8/20 μ s)
- Low leakage current:
 - 25nA typical at 27°C
 - 100nA typical at 85°C
- Low capacitance: 154pF
- Integrated IEC 61000-4-2 ESD protection

2 Applications

- 48V USB Type-C EPR
- Power lines

3 Description

The TVS5200 robustly shunts up to 30A of IEC 61000-4-5 fault current to protect systems from high power transients or lightning strikes. The TVS5200 uses a unique feedback mechanism to provide precise flat clamping during a fault, reinforcing system exposure below 60V. The tight voltage regulation allows designers to confidently select system components with a lower voltage tolerance, lowering system costs and complexity without sacrificing robustness.

In addition, the TVS5200 is available in a 1.6mm \times 1.6mm footprint, which is designed for space constrained applications. The extremely low device leakage and capacitance allows a minimal effect on the protected line.

The TVS5200 is part of TI's Flat-Clamp family of surge devices. For more information on the other devices in the family, see the [Related Products](#) section.

Package Information

PART NUMBER	PACKAGE ⁽¹⁾	PACKAGE SIZE ⁽²⁾
TVS5200	VEB (DFN1616, 6)	1.6mm \times 1.6mm

(1) For more information, see the orderable addendum at the end of the datasheet.

(2) The package size (length \times width) is a nominal value and includes pins, where applicable.

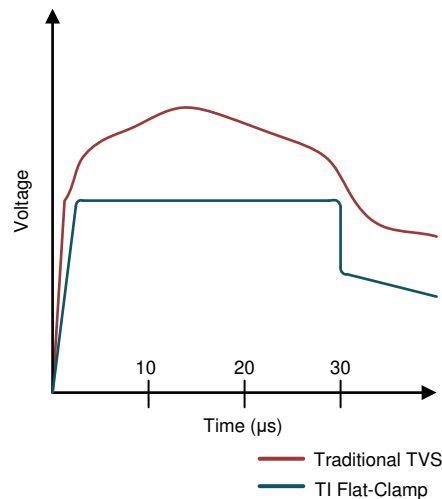

Voltage Clamp Response to 8/20 μ s Surge Event

Table of Contents

1 Features	1	7.4 Device Functional Modes.....	8
2 Applications	1	8 Application and Implementation	9
3 Description	1	8.1 Application Information.....	9
4 Related Products	3	8.2 Typical Application.....	9
5 Pin Configuration and Functions	4	8.3 Power Supply Recommendations.....	10
6 Specifications	5	8.4 Layout.....	10
6.1 Absolute Maximum Ratings.....	5	9 Device and Documentation Support	11
6.2 ESD Ratings - JEDEC.....	5	9.1 Documentation Support.....	11
6.3 ESD Ratings - IEC.....	5	9.2 Receiving Notification of Documentation Updates....	11
6.4 Recommended Operating Conditions.....	5	9.3 Support Resources.....	11
6.5 Thermal Information.....	5	9.4 Trademarks.....	11
6.6 Electrical Characteristics.....	6	9.5 Electrostatic Discharge Caution.....	11
6.7 Typical Characteristics.....	7	9.6 Glossary.....	11
7 Detailed Description	8	10 Revision History	11
7.1 Overview.....	8	11 Mechanical, Packaging, and Orderable Information	11
7.2 Functional Block Diagram.....	8		
7.3 Feature Description.....	8		

4 Related Products

Device	V _{RWM} (V)	V _{CLAMP} at I _{pp} (V)	I _{pp} (8/20 μs) (A)	Leakage Current (nA)	Polarity	Package
TVS0500	5	9.2	43	0.07	Unidirectional	DRV (SON-6)
TVS0701	7	11	30	0.25	Bidirectional	DRB (SON-8)
TVS1400	14	18.4	43	2.2	Unidirectional	DRV (SON-6)
TVS1401	14	20.5	30	1.1	Bidirectional	DRB (SON-8)
TVS1800	18	22.7	40	1.2	Unidirectional	DRV (SON-6)
TVS1801	18	27.4	30	0.4	Bidirectional	DRB (SON-8)
TVS2200	22	27.6	40	3.5	Unidirectional	DRV (SON-6)
TVS2201	22	29.6	30	2	Bidirectional	DRB (SON-8)
TVS2210	22	27.6	25	6	Unidirectional	YMZ (0402)
TVS2700	27	32.5	40	1.8	Unidirectional	DRV (SON-6)
TVS2701	27	34	27	0.8	Bidirectional	DRB (SON-8)
TVS3300	33	38	35	19	Unidirectional	DRV (SON-6), YZF (WCSP)
TVS3301	33	40	27	2.5	Bidirectional	DRB (SON-8)
TVS4000	40	50.4	24	4.45	Unidirectional	VEB (DFN1616)
TVS5200	52	60.5	30	20	Unidirectional	VEB (DFN1616)
TVS5800	58	70.9	25	6	Unidirectional	VEB (DFN1616)

5 Pin Configuration and Functions

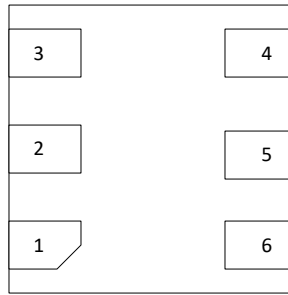

Figure 5-1. VEB Package, 6-Pin DFN1616

Table 5-1. Pin Functions

PIN		TYPE ⁽¹⁾	DESCRIPTION
NAME	NO.		
IN	4, 5, 6	I	ESD and surge protected channel
GND	1, 2, 3	GND	Ground

(1) I = input, GND = ground

6 Specifications

6.1 Absolute Maximum Ratings

$T_A = 27^\circ\text{C}$ (unless otherwise noted)⁽¹⁾

		MIN	MAX	UNIT
Maximum Surge	IEC 61000-4-5 Current (8/20 μs)		30	A
	IEC 61000-4-5 Power (8/20 μs)		1875	W
T_A	Ambient Operating Temperature	-40	125	$^\circ\text{C}$
T_{stg}	Storage Temperature	-65	150	$^\circ\text{C}$

- (1) Operation outside the Absolute Maximum Ratings may cause permanent device damage. Absolute maximum ratings do not imply functional operation of the device at these or any other conditions beyond those listed under Recommended Operating Conditions. If briefly operating outside the Recommended Operating Conditions but within the Absolute Maximum Ratings, the device may not sustain damage, but it may not be fully functional. Operating the device in this manner may affect device reliability, functionality, performance, and shorten the device lifetime

6.2 ESD Ratings - JEDEC

			VALUE	UNIT
$V_{\text{(ESD)}}$	Electrostatic discharge	Human body model (HBM), per ANSI/ESDA/JEDEC JS-001, all pins ⁽¹⁾	± 2000	V
		Charged device model (CDM), per JEDEC specification JESD22C101, all pins ⁽²⁾	± 500	

- (1) JEDEC document JEP155 states that 500V HBM allows safe manufacturing with a standard ESD control process.
 (2) JEDEC document JEP157 states that 250V CDM allows safe manufacturing with a standard ESD control process.

6.3 ESD Ratings - IEC

			VALUE	UNIT
$V_{\text{(ESD)}}$	Electrostatic discharge	IEC 61000-4-2 contact discharge	± 15	kV
		IEC 61000-4-2 air-gap discharge	± 15	

6.4 Recommended Operating Conditions

over operating free-air temperature range (unless otherwise noted)

PARAMETER		MIN	NOM	MAX	UNIT
V_{RWM}	Reverse Stand-off Voltage			52	V

6.5 Thermal Information

THERMAL METRIC ⁽¹⁾		TVS5200	UNIT
		VEB (DFN1616)	
		6 PINS	
R_{qJA}	Junction-to-ambient thermal resistance	132.1	$^\circ\text{C}/\text{W}$
$R_{\text{qJC(top)}}$	Junction-to-case (top) thermal resistance	61.5	$^\circ\text{C}/\text{W}$
R_{qJB}	Junction-to-board thermal resistance	34.5	$^\circ\text{C}/\text{W}$
Y_{JT}	Junction-to-top characterization parameter	1.04	$^\circ\text{C}/\text{W}$
Y_{JB}	Junction-to-board characterization parameter	34.4	$^\circ\text{C}/\text{W}$
$R_{\text{qJC(bot)}}$	Junction-to-case (bottom) thermal resistance	N/A	$^\circ\text{C}/\text{W}$

- (1) For more information about traditional and new thermal metrics, see the [Semiconductor and IC Package Thermal Metrics](#) application note.

6.6 Electrical Characteristics

over operating free-air temperature range (unless otherwise noted)

PARAMETER		TEST CONDITIONS	MIN	TYP	MAX	UNIT
V_{RWM}	Reverse Stand-off Voltage		-0.5		52	V
I_{LEAK}	Leakage Current	Measured at $V_{IN} = V_{RWM}$ $T_A = 27^\circ\text{C}$		25	800	nA
		Measured at $V_{IN} = V_{RWM}$ $T_A = 85^\circ\text{C}$		100	1300	nA
		Measured at $V_{IN} = V_{RWM}$ $T_A = 105^\circ\text{C}$		220	1500	nA
V_F	Forward Voltage	$I_{IN} = 1\text{mA}$ from GND to IO	0.25	0.5	0.65	V
V_{BR}	Break-down Voltage	$I_{IN} = 1\text{mA}$ from IO to GND	54			V
V_{CLAMP}	Clamp Voltage	10A IEC 61000-4-5 Surge (8/20 μs) from IO to GND, $V_{IN} = 0\text{V}$ before surge, 27°C		58.6	60	V
		20A IEC 61000-4-5 Surge (8/20 μs) from IO to GND, $V_{IN} = 0\text{V}$ before surge, 27°C		58.9	60	V
R_{DYN}	8/20 μs surge dynamic resistance	Calculated from V_{CLAMP} at $.5 \cdot I_{pp}$ and I_{pp} surge current levels, 27°C		26		m Ω
C_{IN}	Input pin capacitance	$V_{IN} = V_{RWM}$, $f = 1\text{MHz}$, 30mV_{pp} , IO to GND		154		pF

6.7 Typical Characteristics

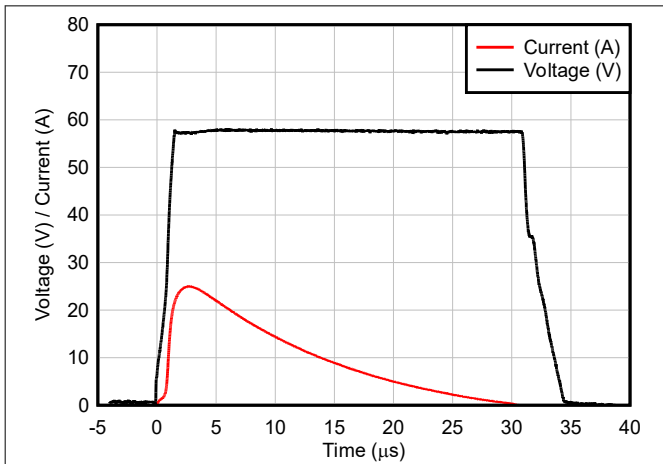

Figure 6-1. 8/20µs Surge Response at 25A

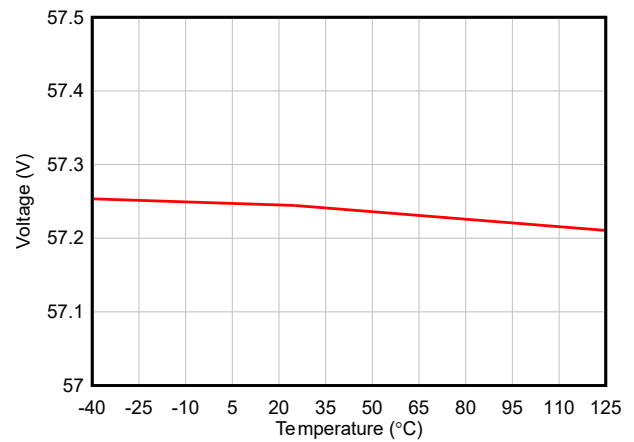

Figure 6-2. Breakdown Voltage (1mA) vs Temperature

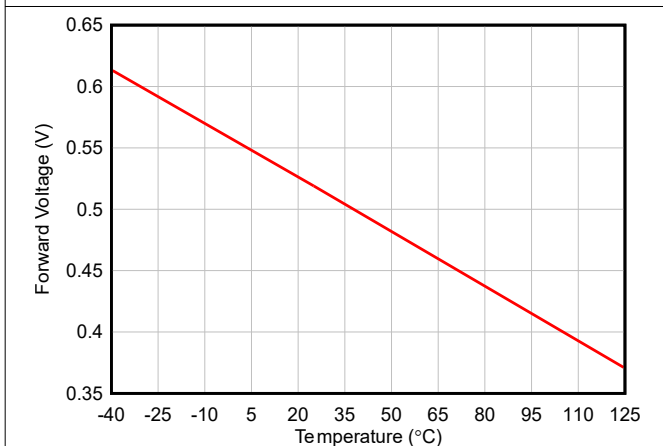

Figure 6-3. Forward Voltage vs Temperature

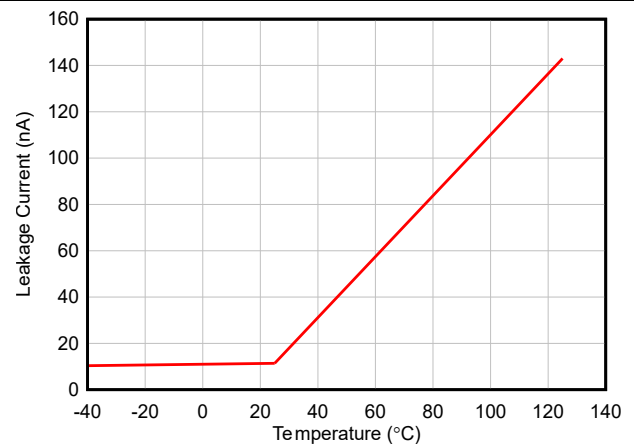

Figure 6-4. Leakage Current vs Temperature at 52V

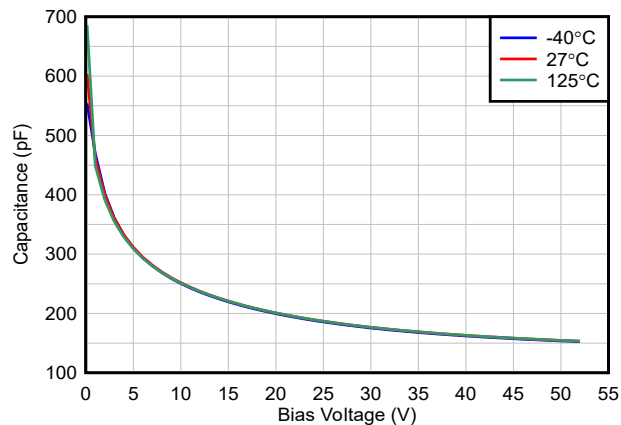

Figure 6-5. Capacitance vs Bias Voltage Across Temperature

7 Detailed Description

7.1 Overview

The TVS5200 is a precision clamp with a low, flat clamping voltage during transient overvoltage events like surge and protecting the system with zero voltage overshoot. For a detailed overview of the Flat-Clamp family of devices, please reference [TI's Flat-Clamp surge protection technology for efficient system protection](#) white paper. This document explains in detail the functional operation of the devices and how the TVS5200 impacts and improves system design.

7.2 Functional Block Diagram

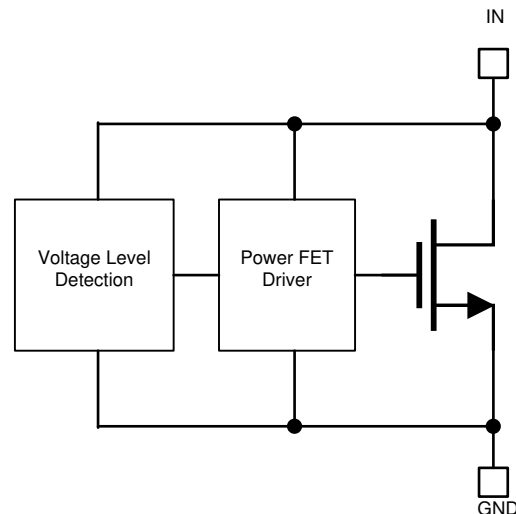

7.3 Feature Description

The TVS5200 is a precision clamp that handles 30A of IEC 61000-4-5 8/20 μ s surge pulse. The flat clamping feature helps keep the clamping voltage very low to keep the downstream circuits from being stressed. The flat clamping feature can also help end-equipment designers save cost by opening up the possibility to use lower-cost, lower voltage tolerant downstream ICs. The TVS5200 has minimal leakage under the standoff voltage of 52V, making TVS5200 a good candidate for applications where low leakage and power dissipation is a necessity. IEC 61000-4-2 ratings make TVS5200 a robust protection design for ESD events. Wide ambient temperature range of -40°C to +125°C, a good candidate for most applications. Compact packages enables the TVS5200 to be used in small devices and save board area.

7.4 Device Functional Modes

7.4.1 Protection Specifications

The TVS5200 is specified according to both the IEC 61000-4-5 standard. The IEC 61000-4-5 standard requires protection against a pulse with a rise time of 8 μ s and a half length of 20 μ s.

The TVS5200 has been tested according to IEC 61000-4-5 to pass a \pm 1kV surge test through a 42 Ω coupling resistor and a 0.5 μ F capacitor. This test is a common test requirement for industrial signal I/O lines and the TVS5200 is designed as a protection option for applications with that requirement.

The TVS5200 also integrates IEC 61000-4-2 level 4 ESD Protection. These combine to maintain that the device can protect against most transient conditions regardless of length or type.

For more information on TI's test methods for Surge, ESD, and EFT testing, reference [TI's IEC 61000-4x Testing Application Note](#)

8 Application and Implementation

Note

Information in the following applications sections is not part of the TI component specification, and TI does not warrant its accuracy or completeness. TI's customers are responsible for determining suitability of components for their purposes, as well as validating and testing their design implementation to confirm system functionality.

8.1 Application Information

The TVS5200 can be used to protect any power, analog, or digital signal from transient fault conditions caused by the environment or other electrical components.

8.2 Typical Application

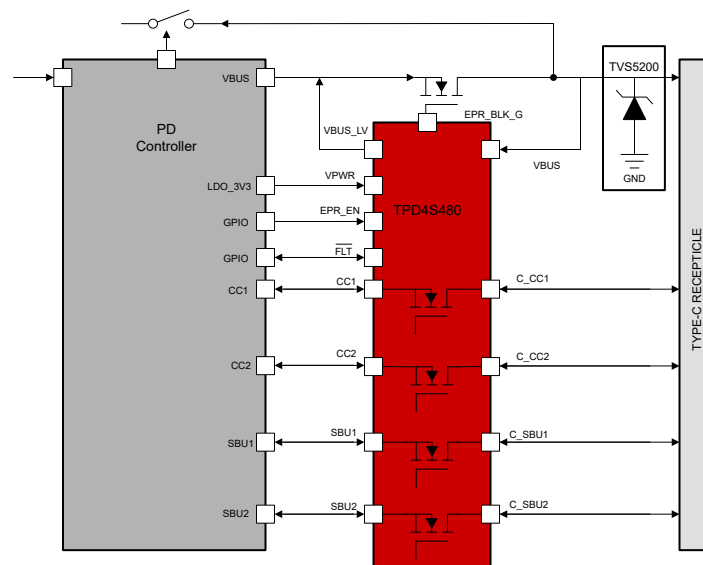

Figure 8-1. TVS5200 Application Schematic

8.2.1 Design Requirements

An application for the TVS5200 is protecting a USB Extended Power Range (EPR) Port Protector. In this example, the TVS5200 is protecting the VBUS pin of a USB Type-C® 48V EPR Port Protector such as TPD4S480, that has a nominal voltage of 48V and a clamping voltage requirement of 63V. The TVS5200 has a max clamping voltage of 60V which makes the device a great option for protection. Also, the maximum expected VBUS voltage can reach 50.9V, amounting to a 5% tolerance which means the working voltage of the TVS needs to be at or above 50.9V. For more information on the EPR Port Protector, see the [TPD4S480 datasheet](#).

Most industrial interfaces such as this require protection against $\pm 1\text{kV}$ surge test through a 42Ω coupling resistor and a $0.5\mu\text{F}$ capacitor, equaling roughly 24A of surge current. Without any input protection, if a surge event is caused by lightning, coupling, ringing, or any other fault condition this input voltage can rise to hundreds of volts for multiple microseconds, violating the absolute maximum input voltage and harming the device. An optimal surge protection diode maximizes the useable voltage range while still clamping at a safe level for the system, TI's Flat-Clamp technology provides the best protection option.

8.2.2 Detailed Design Procedure

If the TVS5200 is in place to protect the device, during a surge event the voltage rises to the breakdown of the diode at V , and then the TVS5200 turns on, shunting the surge current to ground. With the low dynamic resistance of the TVS5200, large amounts of surge current has minimal impact on the clamping voltage. The

dynamic resistance of the TVS5200 is around 26mΩ, which means 30A of surge current causes a voltage raise of $30A \times 26m\Omega = 0.78V$. Because the device turns on at 57.8V, this means the TPD4S480 input is exposed to a maximum of $57.8V + 0.78V = 58.6V$ during surge pulses. This maintains robust protection of your circuit.

The small size of the device also improves fault protection by lowering the effect of fault current coupling onto neighboring traces. The small form factor of the TVS5200 allows the device to be placed extremely close to the input connector, lowering the length of the path fault current takes through the system compared to larger protection options.

8.3 Power Supply Recommendations

The TVS5200 is a clamping device so there is no need to power the device. To verify that the device functions properly do not violate the recommended V_{IN} voltage range (0V to 52V) .

8.4 Layout

8.4.1 Layout Guidelines

The optimum placement is close to the connector. EMI during an ESD event can couple from the trace being struck to other nearby unprotected traces, resulting in early system failures. The PCB designer must minimize the possibility of EMI coupling by keeping any unprotected traces away from the protected traces which are between the TVS and the connector.

Route the protected traces straight. Eliminate any sharp corners on the protected traces between the TVS5200 and the connector by using rounded corners with the largest radii possible. Electric fields tend to build up on corners, increasing EMI coupling.

8.4.2 Layout Example

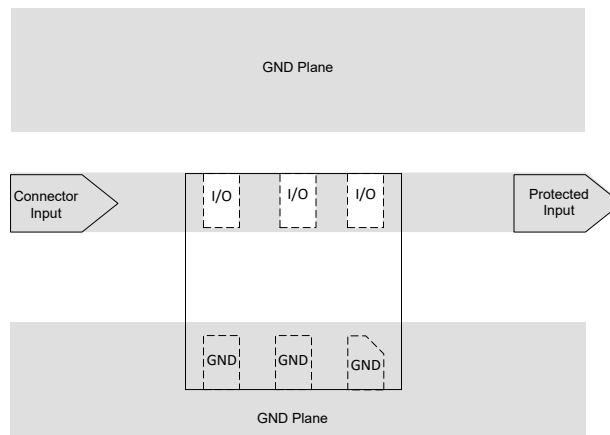

Figure 8-2. TVS5200 DFN1616 Layout

9 Device and Documentation Support

9.1 Documentation Support

9.1.1 Related Documentation

For related documentation, see the following:

- Texas Instruments, [Flat-Clamp TVS Evaluation Kit](#)
- Texas Instruments, [How to select a Surge Diode](#)
- Texas Instruments, [Flat-Clamp surge protection technology for efficient system protection](#)

9.2 Receiving Notification of Documentation Updates

To receive notification of documentation updates, navigate to the device product folder on [ti.com](#). Click on *Notifications* to register and receive a weekly digest of any product information that has changed. For change details, review the revision history included in any revised document.

9.3 Support Resources

TI E2E™ [support forums](#) are an engineer's go-to source for fast, verified answers and design help — straight from the experts. Search existing answers or ask your own question to get the quick design help you need.

Linked content is provided "AS IS" by the respective contributors. They do not constitute TI specifications and do not necessarily reflect TI's views; see TI's [Terms of Use](#).

9.4 Trademarks

TI E2E™ is a trademark of Texas Instruments.

All trademarks are the property of their respective owners.

9.5 Electrostatic Discharge Caution



This integrated circuit can be damaged by ESD. Texas Instruments recommends that all integrated circuits be handled with appropriate precautions. Failure to observe proper handling and installation procedures can cause damage.

ESD damage can range from subtle performance degradation to complete device failure. Precision integrated circuits may be more susceptible to damage because very small parametric changes could cause the device not to meet its published specifications.

9.6 Glossary

[TI Glossary](#) This glossary lists and explains terms, acronyms, and definitions.

10 Revision History

NOTE: Page numbers for previous revisions may differ from page numbers in the current version.

DATE	REVISION	NOTES
May 2026	*	Initial Release

11 Mechanical, Packaging, and Orderable Information

The following pages include mechanical, packaging, and orderable information. This information is the most current data available for the designated devices. This data is subject to change without notice and revision of this document. For browser-based versions of this data sheet, refer to the left-hand navigation.

PACKAGING INFORMATION

Orderable part number	Status (1)	Material type (2)	Package Pins	Package qty Carrier	RoHS (3)	Lead finish/ Ball material (4)	MSL rating/ Peak reflow (5)	Op temp (°C)	Part marking (6)
TVS5200VEBR	Active	Production	UQFN-HR (VEB) 6	3000 LARGE T&R	Yes	SN	Level-1-260C-UNLIM	-40 to 125	SC

(1) **Status:** For more details on status, see our [product life cycle](#).

(2) **Material type:** When designated, preproduction parts are prototypes/experimental devices, and are not yet approved or released for full production. Testing and final process, including without limitation quality assurance, reliability performance testing, and/or process qualification, may not yet be complete, and this item is subject to further changes or possible discontinuation. If available for ordering, purchases will be subject to an additional waiver at checkout, and are intended for early internal evaluation purposes only. These items are sold without warranties of any kind.

(3) **RoHS values:** Yes, No, RoHS Exempt. See the [TI RoHS Statement](#) for additional information and value definition.

(4) **Lead finish/Ball material:** Parts may have multiple material finish options. Finish options are separated by a vertical ruled line. Lead finish/Ball material values may wrap to two lines if the finish value exceeds the maximum column width.

(5) **MSL rating/Peak reflow:** The moisture sensitivity level ratings and peak solder (reflow) temperatures. In the event that a part has multiple moisture sensitivity ratings, only the lowest level per JEDEC standards is shown. Refer to the shipping label for the actual reflow temperature that will be used to mount the part to the printed circuit board.

(6) **Part marking:** There may be an additional marking, which relates to the logo, the lot trace code information, or the environmental category of the part.

Multiple part markings will be inside parentheses. Only one part marking contained in parentheses and separated by a "-" will appear on a part. If a line is indented then it is a continuation of the previous line and the two combined represent the entire part marking for that device.

Important Information and Disclaimer:The information provided on this page represents TI's knowledge and belief as of the date that it is provided. TI bases its knowledge and belief on information provided by third parties, and makes no representation or warranty as to the accuracy of such information. Efforts are underway to better integrate information from third parties. TI has taken and continues to take reasonable steps to provide representative and accurate information but may not have conducted destructive testing or chemical analysis on incoming materials and chemicals. TI and TI suppliers consider certain information to be proprietary, and thus CAS numbers and other limited information may not be available for release.

In no event shall TI's liability arising out of such information exceed the total purchase price of the TI part(s) at issue in this document sold by TI to Customer on an annual basis.

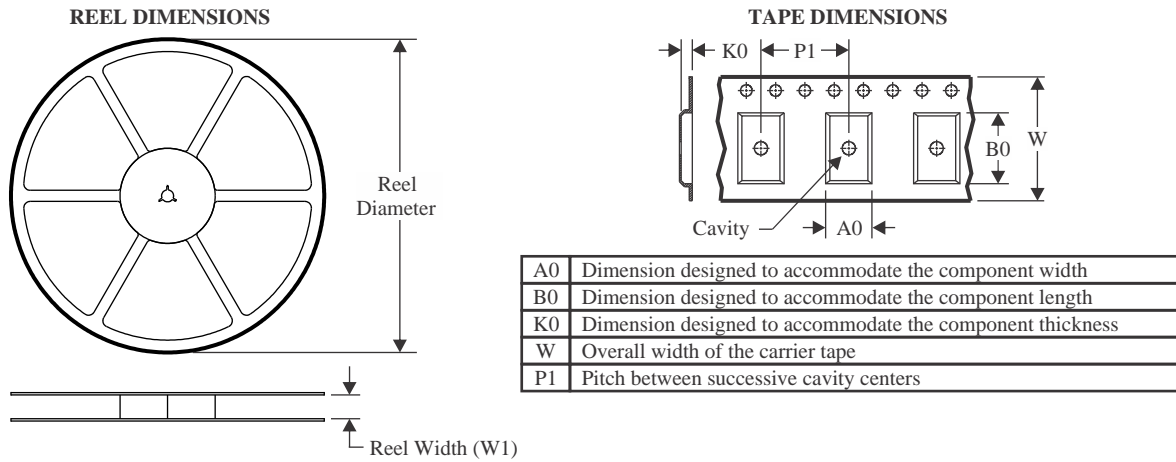
TAPE AND REEL INFORMATION

QUADRANT ASSIGNMENTS FOR PIN 1 ORIENTATION IN TAPE

*All dimensions are nominal

Device	Package Type	Package Drawing	Pins	SPQ	Reel Diameter (mm)	Reel Width W1 (mm)	A0 (mm)	B0 (mm)	K0 (mm)	P1 (mm)	W (mm)	Pin1 Quadrant
TVS5200VEBR	UQFN-HR	VEB	6	3000	180.0	8.4	1.85	1.85	0.85	4.0	8.0	Q1

TAPE AND REEL BOX DIMENSIONS

*All dimensions are nominal

Device	Package Type	Package Drawing	Pins	SPQ	Length (mm)	Width (mm)	Height (mm)
TVS5200VEBR	UQFN-HR	VEB	6	3000	210.0	185.0	35.0

EXAMPLE BOARD LAYOUT

VEB0006A

UQFN-HR - 0.6 mm max height

PLASTIC SMALL OUTLINE - NO LEAD

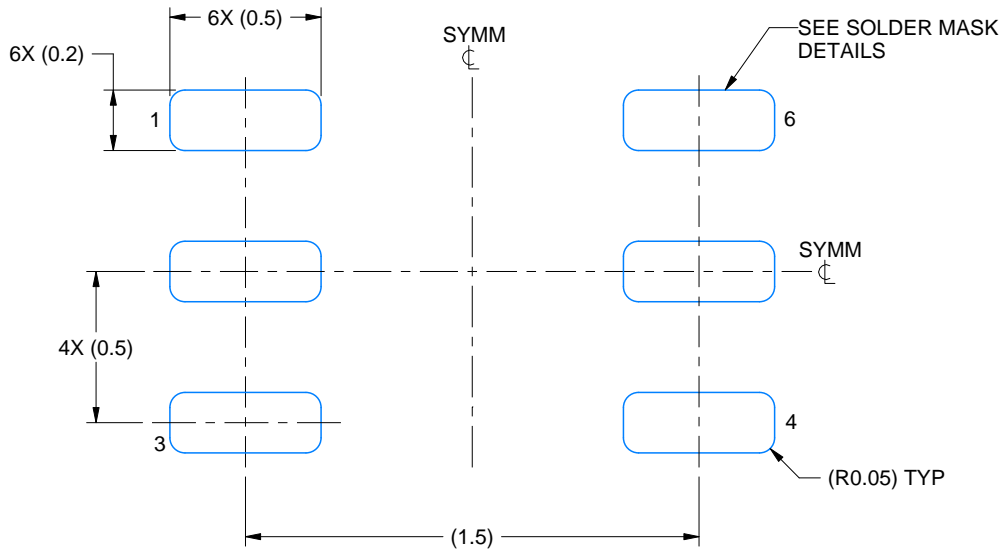

LAND PATTERN EXAMPLE
EXPOSED METAL SHOWN
SCALE: 40X

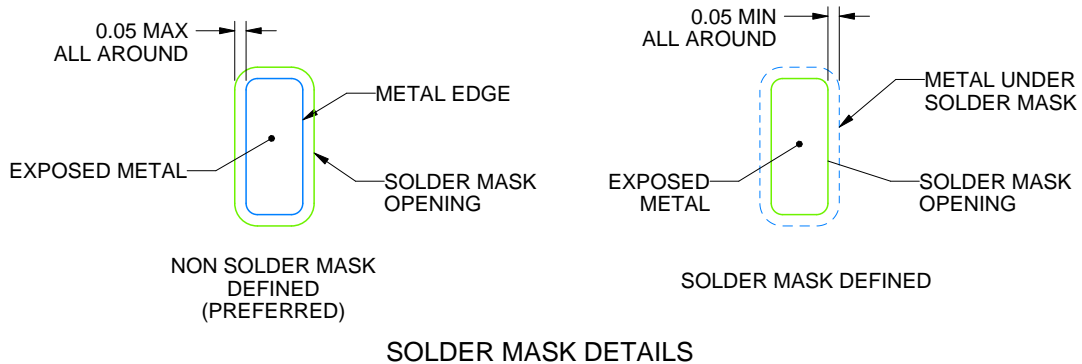

4231688/B 06/2026

NOTES: (continued)

3. For more information, see Texas Instruments literature number SLUA271 (www.ti.com/lit/sluea271).

EXAMPLE STENCIL DESIGN

VEB0006A

UQFN-HR - 0.6 mm max height

PLASTIC SMALL OUTLINE - NO LEAD

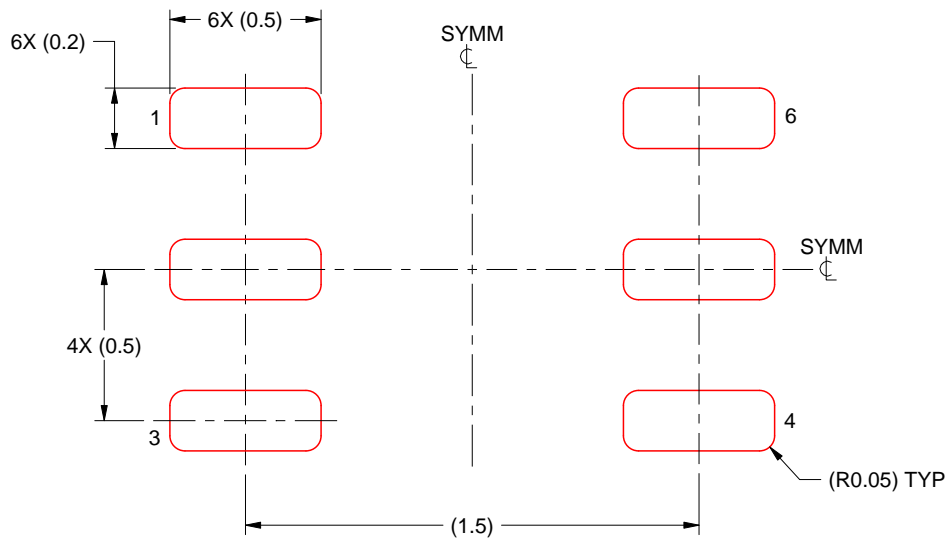

SOLDER PASTE EXAMPLE
BASED ON 0.125 mm THICK STENCIL
SCALE: 40X

4231688/B 06/2026

NOTES: (continued)

4. Laser cutting apertures with trapezoidal walls and rounded corners may offer better paste release. IPC-7525 may have alternate design recommendations.

IMPORTANT NOTICE AND DISCLAIMER

TI PROVIDES TECHNICAL AND RELIABILITY DATA (INCLUDING DATASHEETS), DESIGN RESOURCES (INCLUDING REFERENCE DESIGNS), APPLICATION OR OTHER DESIGN ADVICE, WEB TOOLS, SAFETY INFORMATION, AND OTHER RESOURCES "AS IS" AND WITH ALL FAULTS, AND DISCLAIMS ALL WARRANTIES, EXPRESS AND IMPLIED, INCLUDING WITHOUT LIMITATION ANY IMPLIED WARRANTIES OF MERCHANTABILITY, FITNESS FOR A PARTICULAR PURPOSE OR NON-INFRINGEMENT OF THIRD PARTY INTELLECTUAL PROPERTY RIGHTS.

These resources are intended for skilled developers designing with TI products. You are solely responsible for (1) selecting the appropriate TI products for your application, (2) designing, validating and testing your application, and (3) ensuring your application meets applicable standards, and any other safety, security, regulatory or other requirements.

These resources are subject to change without notice. TI grants you permission to use these resources only for development of an application that uses the TI products described in the resource. Other reproduction and display of these resources is prohibited. No license is granted to any other TI intellectual property right or to any third party intellectual property right. TI disclaims responsibility for, and you fully indemnify TI and its representatives against any claims, damages, costs, losses, and liabilities arising out of your use of these resources.

TI's products are provided subject to [TI's Terms of Sale](#), [TI's General Quality Guidelines](#), or other applicable terms available either on ti.com or provided in conjunction with such TI products. TI's provision of these resources does not expand or otherwise alter TI's applicable warranties or warranty disclaimers for TI products. Unless TI explicitly designates a product as custom or customer-specified, TI products are standard, catalog, general purpose devices.

TI objects to and rejects any additional or different terms you may propose.

Copyright © 2026, Texas Instruments Incorporated

Last updated 10/2025