

## HIGH-SPEED PWM CONTROLLER

### FEATURES

- Qualified for Automotive Applications
- Improved Version of the UC3825 PWM
- Compatible With Voltage-Mode or Current-Mode Control Methods
- Practical Operation at Switching Frequencies to 1 MHz
- 50-ns Propagation Delay to Output
- High-Current Dual Totem-Pole Outputs: 2 A (Peak)
- Trimmed Oscillator Discharge Current
- Low 100- $\mu$ A Startup Current
- Pulse-by-Pulse Current-Limiting Comparator
- Latched Overcurrent Comparator With Full-Cycle Restart

### DESCRIPTION

The UC2825A pulse-width modulation (PWM) controller is an improved versions of the standard UC3825. Performance enhancements have been made to several of the circuit blocks. Error amplifier gain bandwidth product is 12 MHz, while input offset voltage is 2 mV. Current limit threshold is specified to a tolerance of 5%. Oscillator discharge current is specified at 10 mA for accurate dead-time control. Frequency accuracy is improved to 6%. Startup supply current, typically 100  $\mu$ A, is ideal for off-line applications. The output drivers are redesigned to actively sink current during undervoltage lockout (UVLO) at no expense to the startup current specification. In addition, each output is capable of 2-A peak currents during transitions.

### BLOCK DIAGRAM

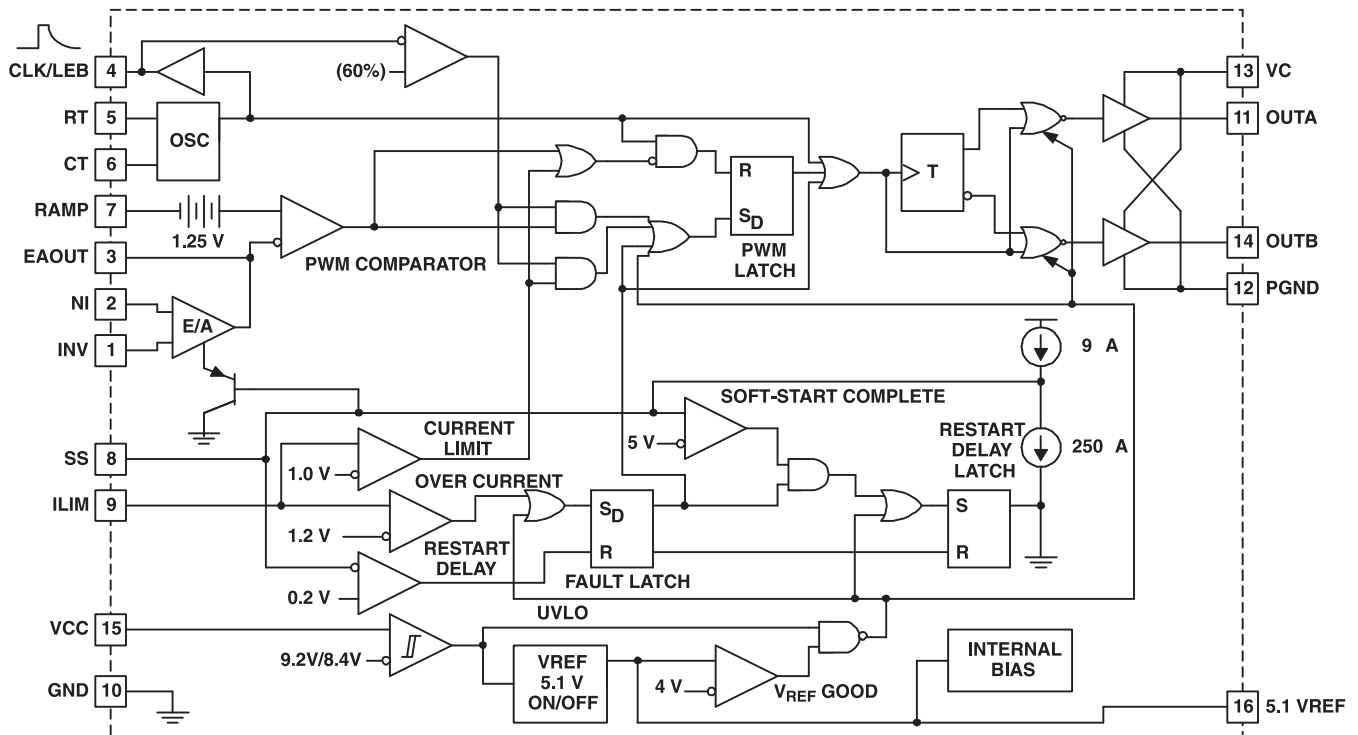

Please be aware that an important notice concerning availability, standard warranty, and use in critical applications of Texas Instruments semiconductor products and disclaimers thereto appears at the end of this data sheet.



These devices have limited built-in ESD protection. The leads should be shorted together or the device placed in conductive foam during storage or handling to prevent electrostatic damage to the MOS gates.

## DESCRIPTION (CONTINUED)

Functional improvements have also been implemented. The shutdown comparator is now a high-speed overcurrent comparator with a threshold of 1.2 V. The overcurrent comparator sets a latch that ensures full discharge of the soft-start capacitor before allowing a restart. While the fault latch is set, the outputs are in the low state. In the event of continuous faults, the soft-start capacitor is fully charged before discharge to insure that the fault frequency does not exceed the designed soft start period. The CLOCK pin has become CLK/LEB. This pin combines the functions of clock output and leading edge blanking adjustment and has been buffered for easier interfacing.

The UC2825A has dual alternating outputs and the same pin configuration of the UC3825. "A" version parts have UVLO thresholds identical to the original UC3825.

See the application report, *The UC3823A,B and UC3825A,B Enhanced Generation of PWM Controllers (SLUA125)* for detailed technical and application information.

## ORDERING INFORMATION<sup>(1)</sup>

T <sub>J</sub>	MAXIMUM DUTY CYCLE	UVLO	PACKAGE <sup>(2)</sup>		ORDERABLE PART NUMBER	TOP-SIDE MARKING
–40°C to 125°C	<50%	9.2 V/8.4 V	SOIC – DW	Reel of 2000	UC2825AQDWRQ1	UC2825AQDW

(1) For the most current package and ordering information, see the Package Option Addendum at the end of this document, or see the TI web site at [www.ti.com](http://www.ti.com).

(2) Package drawings, thermal data, and symbolization are available at [www.ti.com/packaging](http://www.ti.com/packaging).

## PIN ASSIGNMENTS

DW PACKAGE  
(TOP VIEW)

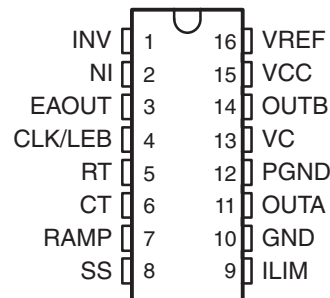

## TERMINAL FUNCTIONS

TERMINAL		I/O	DESCRIPTION
NAME	NO.		
CLK/LEB	4	O	Output of the internal oscillator
CT	6	I	Timing capacitor connection for oscillator frequency programming. The timing capacitor should be connected to the device ground using minimal trace length.
EAOUT	3	O	Output of the error amplifier for compensation
GND	10		Analog ground return
ILIM	9	I	Input to the current limit comparator
INV	1	I	Inverting input to the error amplifier
NI	2	I	Noninverting input to the error amplifier
OUTA	11	O	High-current totem-pole output A of the on-chip drive stage
OUTB	14	O	High-current totem-pole output B of the on-chip drive stage
PGND	12		Ground return for the output driver stage
RAMP	7	I	Noninverting input to the PWM comparator with 1.25-V internal input offset. In voltage-mode operation, this serves as the input voltage feed-forward function by using the CT ramp. In peak current-mode operation, this serves as the slope compensation input.
RT	5	I	Timing resistor connection for oscillator frequency programming
SS	8	I	Soft-start input and the maximum duty cycle clamp
VC	13		Power supply for the output stage. This pin should be bypassed with a 0.1- $\mu$ F monolithic ceramic low ESL capacitor with minimal trace lengths.
VCC	15		Power supply for the device. This pin should be bypassed with a 0.1- $\mu$ F monolithic ceramic low ESL capacitor with minimal trace lengths
VREF	16	O	5.1-V reference. For stability, the reference should be bypassed with a 0.1- $\mu$ F monolithic ceramic low ESL capacitor and minimal trace length to the ground plane.

## ABSOLUTE MAXIMUM RATINGS<sup>(1)</sup>

over operating free-air temperature range unless otherwise noted

			VALUE
$V_{IN}$	Supply voltage	VC, VCC	22 V
$I_O$	Source or sink current, dc	OUTA, OUTB	0.5 A
$I_O$	Source or sink current, pulse (0.5 $\mu$ s)	OUTA, OUTB	2.2 A
	Analog inputs	INV, NI, RAMP	-0.3 V to 7 V
		ILIM, SS	-0.3 V to 6 V
	Power ground	PGND	$\pm 0.2$ V
$I_{CLK}$	Clock output current	CLK/LEB	-5 mA
$I_{O(EA)}$	Error amplifier output current	EAOUT	5 mA
$I_{SS}$	Soft-start sink current	SS	20 mA
$I_{OSC}$	Oscillator charging current	RT	-5 mA
$T_J$	Operating virtual junction temperature range		-55°C to 150°C
$T_{stg}$	Storage temperature range		-65°C to 150°C
	Lead temperature 1,6 mm (1/16 in) from case for 10 s		300°C

(1) Stresses beyond those listed under *absolute maximum ratings* may cause permanent damage to the device. These are stress ratings only, and functional operation of the device at these or any other conditions beyond those indicated under *recommended operating conditions* is not implied. Exposure to absolute-maximum-rated conditions for extended periods may affect device reliability.

**ELECTRICAL CHARACTERISTICS**
 $T_J = -40^\circ\text{C}$  to  $125^\circ\text{C}$ ,  $R_T = 3.65\text{ k}\Omega$ ,  $C_T = 1\text{ nF}$ ,  $V_{CC} = 12\text{ V}$  (unless otherwise noted)

PARAMETER		TEST CONDITIONS	MIN	TYP	MAX	UNIT
<b>Reference, <math>V_{REF}</math></b>						
$V_O$	Output voltage	$T_J = 25^\circ\text{C}$ , $I_O = 1\text{ mA}$	5.05	5.1	5.15	V
	Line regulation	$12\text{ V} \leq V_{CC} \leq 20\text{ V}$		2	15	mV
	Load regulation	$1\text{ mA} \leq I_O \leq 10\text{ mA}$		5	20	mV
	Total output variation	Line, load, temperature	5.03		5.17	V
	Temperature stability <sup>(1)</sup>	$T_{(min)} < T_J < T_{(max)}$		0.2	0.4	mV/°C
	Output noise voltage <sup>(1)</sup>	$10\text{ Hz} < f < 10\text{ kHz}$		50		$\mu\text{V}_{RMS}$
	Long term stability <sup>(1)</sup>	$T_J = 125^\circ\text{C}$ , 1000 hours		5	25	mV
	Short circuit current	$V_{REF} = 0\text{ V}$	30	60	90	mA
		$T_J = 125^\circ\text{C}$	30		110	
<b>Oscillator</b>						
$f_{OSC}$	Initial accuracy <sup>(1)</sup>	$T_J = 25^\circ\text{C}$	375	400	425	kHz
		$R_T = 6.6\text{ k}\Omega$ , $C_T = 220\text{ pF}$ , $T_J = 25^\circ\text{C}$	0.9	1	1.1	MHz
	Total variation <sup>(1)</sup>	Line, temperature	350		450	kHz
		$R_T = 6.6\text{ k}\Omega$ , $C_T = 220\text{ pF}$	0.85		1.15	MHz
	Voltage stability	$12\text{ V} < V_{CC} < 20\text{ V}$			1	%
	Temperature stability <sup>(1)</sup>	$T_{(min)} < T_J < T_{(max)}$		$\pm 5$		%
	High-level output voltage, clock		3.7	4		V
	Low-level output voltage, clock			0	0.2	V
	Ramp peak		2.6	2.8	3	V
	Ramp valley		0.7	1	1.25	V
	Ramp valley to peak		1.6	1.8	2	V
		$T_J = -40^\circ\text{C}$	1.55		2	
$I_{OSC}$	Oscillator discharge current	$R_T = \text{Open}$ , $V_{CT} = 2\text{ V}$	9	10	11	mA
		$T_J = 125^\circ\text{C}$	8		11	
<b>Error Amplifier</b>						
	Input offset voltage			2	10	mV
	Input bias current			0.6	3	$\mu\text{A}$
	Input offset current			0.1	1	$\mu\text{A}$
	Open loop gain	$1\text{ V} < V_O < 4\text{ V}$	60	95		dB
CMRR	Common-mode rejection ratio	$1.5\text{ V} < V_{CM} < 5.5\text{ V}$	75	95		dB
PSRR	Power-supply rejection ratio	$12\text{ V} < V_{CC} < 20\text{ V}$	85	110		dB
$I_{O(sink)}$	Output sink current	$V_{EAOUT} = 1\text{ V}$	1	2.5		mA
$I_{O(src)}$	Output source current	$V_{EAOUT} = 4\text{ V}$	-0.5	-1.3		mA
	High-level output voltage	$I_{EAOUT} = -0.5\text{ mA}$	4.5	4.7	5	V
	Low-level output voltage	$I_{EAOUT} = -1\text{ mA}$	0	0.5	1	V
	Gain bandwidth product	$f = 200\text{ kHz}$	6	12		MHz
	Slew rate <sup>(1)</sup>		6	9		V/ $\mu\text{s}$

(1) Specified by design

**ELECTRICAL CHARACTERISTICS (continued)**
 $T_J = -40^{\circ}\text{C}$  to  $125^{\circ}\text{C}$ ,  $R_T = 3.65\text{ k}\Omega$ ,  $C_T = 1\text{ nF}$ ,  $V_{CC} = 12\text{ V}$  (unless otherwise noted)

PARAMETER		TEST CONDITIONS	MIN	TYP	MAX	UNIT
<b>PWM Comparator</b>						
$I_{BIAS}$	Bias current, RAMP	$V_{RAMP} = 0\text{ V}$		-1	-8	$\mu\text{A}$
	Minimum duty cycle				0	%
	Maximum duty cycle		85			%
$t_{LEB}$	Leading edge blanking time	$R_{LEB} = 2\text{ k}\Omega$ , $C_{LEB} = 470\text{ pF}$	300	375	450	ns
$R_{LEB}$	Leading edge blanking resistance	$V_{CLK/LEB} = 3\text{ V}$	8	10	12	$\text{k}\Omega$
$V_{ZDC}$	Zero dc threshold voltage, EAOUT	$V_{RAMP} = 0\text{ V}$	1.10	1.25	1.4	V
$t_{DELAY}$	Delay-to-output time <sup>(2)</sup>	$V_{EAOUT} = 2.1\text{ V}$ , $V_{ILIM} = 0\text{ V}$ to $2\text{ V}$ step		50	80	ns
<b>Current Limit / Start Sequence / Fault</b>						
$I_{SS}$	Soft-start charge current	$V_{SS} = 2.5\text{ V}$	8	14	20	$\mu\text{A}$
$V_{SS}$	Full soft-start threshold voltage		4.3	5		V
$I_{DSCH}$	Restart discharge current	$V_{SS} = 2.5\text{ V}$	100	250	350	$\mu\text{A}$
$I_{SS}$	Restart threshold voltage			0.3	0.5	V
$I_{BIAS}$	ILIM bias current	$V_{ILIM} = 0\text{ V}$ to $2\text{ V}$ step			15	A
$I_{CL}$	Current limit threshold voltage		0.95	1	1.05	V
	Overcurrent threshold voltage		1.14	1.2	1.26	V
$t_d$	Delay-to-output time, ILIM <sup>(1)</sup>	$V_{ILIM} = 0\text{ V}$ to $2\text{ V}$ step		50	80	ns
<b>Output</b>						
	Low-level output saturation voltage	$I_{OUT} = 20\text{ mA}$		0.25	0.4	V
		$I_{OUT} = 200\text{ mA}$		1.2	2.2	
	High-level output saturation voltage	$I_{OUT} = -20\text{ mA}$		1.9	2.9	V
		$I_{OUT} = -200\text{ mA}$		2	3	
$t_r$ , $t_f$	Rise/fall time <sup>(2)</sup>	$C_L = 1\text{ nF}$		20	45	ns
<b>Undervoltage Lockout (UVLO)</b>						
	Start threshold voltage		8.4	9.2	9.6	V
	UVLO hysteresis		0.4	0.8	1.2	V
<b>Supply Current</b>						
$I_{SU}$	Startup current	$V_C = V_{CC} = V_{TH} = -0.5\text{ V}$		100	300	$\mu\text{A}$
$I_{CC}$	Input current			28	36	mA

(2) Specified by design

APPLICATION INFORMATION

The oscillator is a sawtooth. The rising edge is governed by a current controlled by the RT pin and value of capacitance at the CT pin (C<sub>CT</sub>). The falling edge of the sawtooth sets dead time for the outputs. Selection of RT should be done first, based on desired maximum duty cycle. CT can then be chosen based on the desired frequency (RT) and D<sub>MAX</sub>. The design equations are:

$$R_T = \frac{3V}{(10\text{ mA}) \times (1 - D_{MAX})} \quad C_T = \frac{(1.6 \times D_{MAX})}{(R_T \times f)} \tag{1}$$

Recommended values for R<sub>T</sub> range from 1 kΩ to 100 kΩ. Control of D<sub>MAX</sub> less than 70% is not recommended.

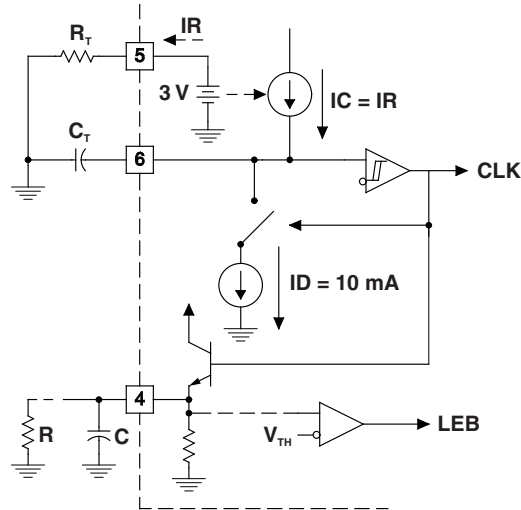

Figure 1. Oscillator

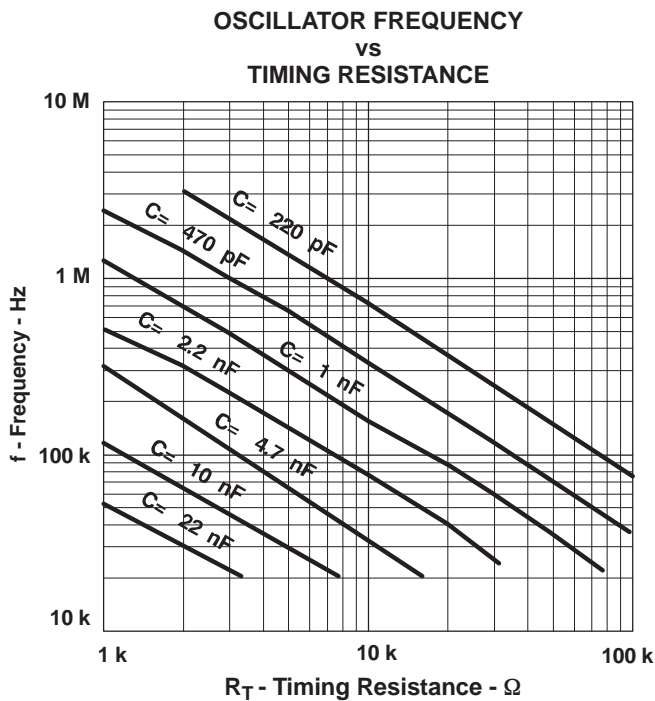

Figure 2.

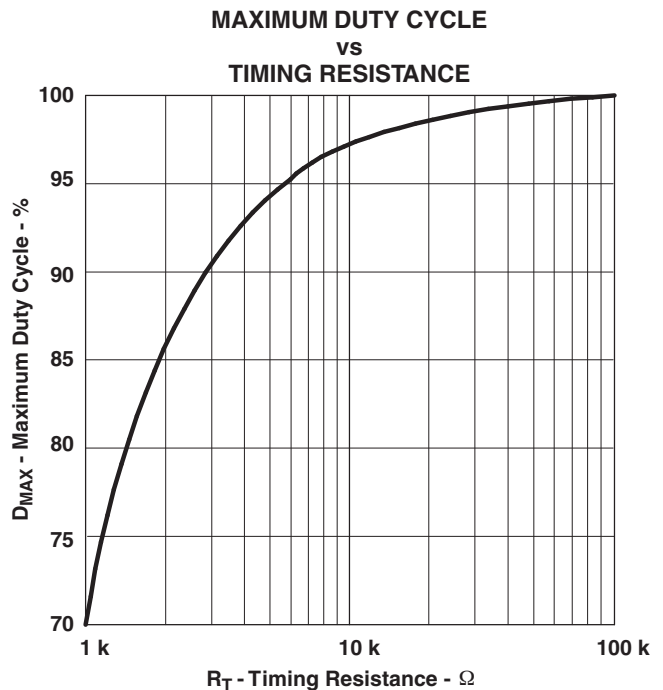

Figure 3.

## Leading Edge Blanking (LEB)

The UC2825A performs fixed-frequency PWM control. The outputs are alternately controlled. During every other cycle, one output is off. Each output then switches at one-half the oscillator frequency, varying in duty cycle from 0% to less than 50%.

To limit maximum duty cycle, the internal clock pulse blanks both outputs low during the discharge time of the oscillator. On the falling edge of the clock, the appropriate output(s) is driven high. The end of the pulse is controlled by the PWM comparator, current limit comparator, or the overcurrent comparator.

Normally the PWM comparator senses a ramp crossing a control voltage (error amplifier output) and terminates the pulse. LEB causes the PWM comparator to be ignored for a fixed amount of time after the start of the pulse. This allows noise inherent with switched mode power conversion to be rejected. The PWM ramp input may not require any filtering as result of LEB.

To program a LEB period, connect a capacitor, C, to CLK/LEB. The discharge time set by C and the internal 10-k $\Omega$  resistor determines the blanked interval. The 10-k $\Omega$  resistor has a 10% tolerance. For more accuracy, an external 2-k $\Omega$  1% resistor (R) can be added, resulting in an equivalent resistance of 1.66 k $\Omega$  with a tolerance of 2.4%. The design equation is:

$$t_{LEB} = 0.5 \times (R \parallel 10 \text{ k}\Omega) \times C \quad (2)$$

Values of R less than 2 k $\Omega$  should not be used.

LEB is also applied to the current limit comparator. After LEB, if the ILIM pin exceeds the 1-V threshold, the pulse is terminated. The overcurrent comparator, however, is not blanked. It catches catastrophic overcurrent faults without a blanking delay. Any time the ILIM pin exceeds 1.2 V, the fault latch is set and the outputs driven low. For this reason, some noise filtering may be required on the ILIM pin.

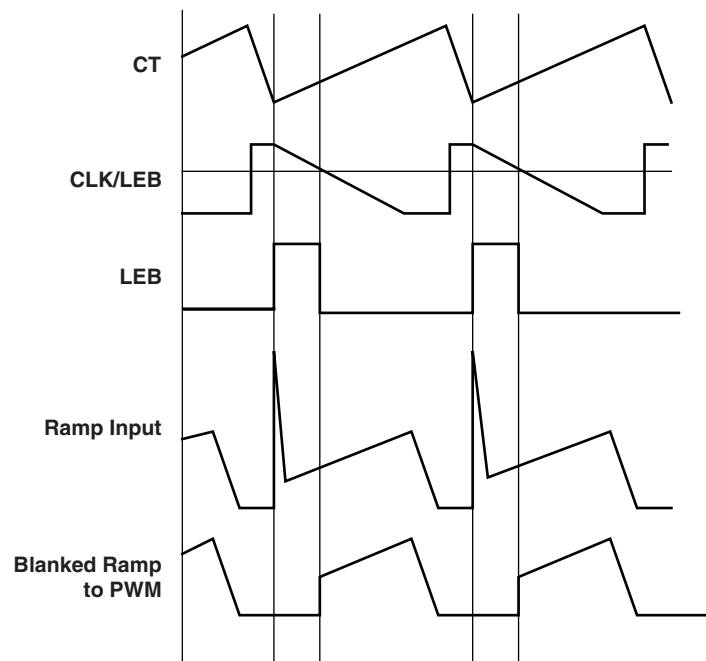

Figure 4. Leading Edge Blanking Operational Waveforms

### UVLO, Soft Start, and Fault Management

Soft start is programmed by a capacitor on the SS pin. At power up, SS is discharged. When SS is low, the error amplifier output is also forced low. While the internal 9- $\mu\text{A}$  source charges the SS pin, the error amplifier output follows until closed loop regulation takes over.

Anytime  $I_{LIM}$  exceeds 1.2 V, the fault latch is set and the output pins are driven low. The soft-start capacitor is then discharged by a 250- $\mu\text{A}$  current sink. No more output pulses are allowed until the soft-start capacitor is fully discharged and  $I_{LIM}$  is below 1.2 V. At this time, the fault latch resets and the chip executes a soft start.

Should the fault latch get set during soft start, the outputs are immediately terminated, but the soft-start capacitor does not discharge until it has been fully charged first. This results in a controlled hiccup interval for continuous fault conditions.

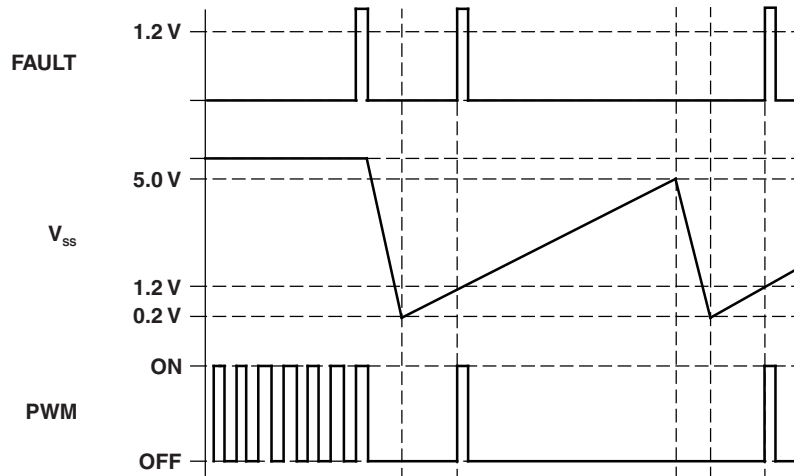
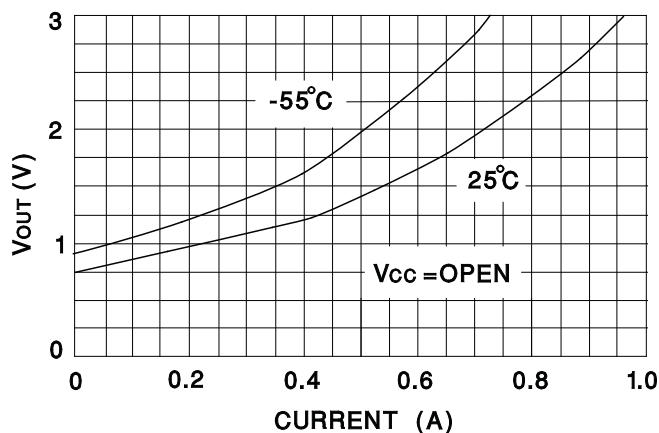

Figure 5. Soft-Start and Fault Waveforms

### Active-Low Outputs During UVLO

The UVLO function forces the outputs to be low and considers both  $V_{CC}$  and  $V_{REF}$  before allowing the chip to operate.



UDG-95108

Figure 6. Output Voltage vs Output Current

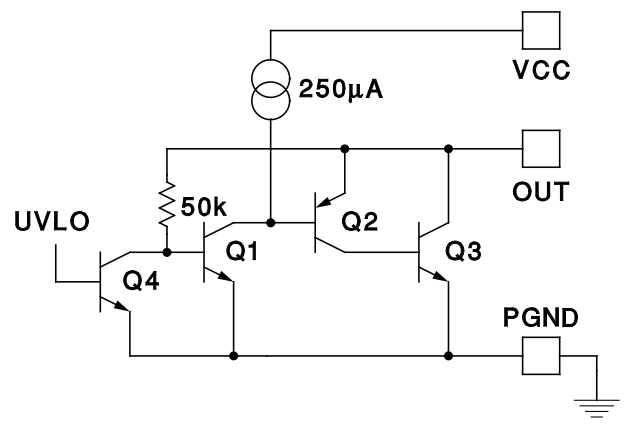

UDG-95106

Figure 7. Output Voltage and Current During UVLO

## Control Methods

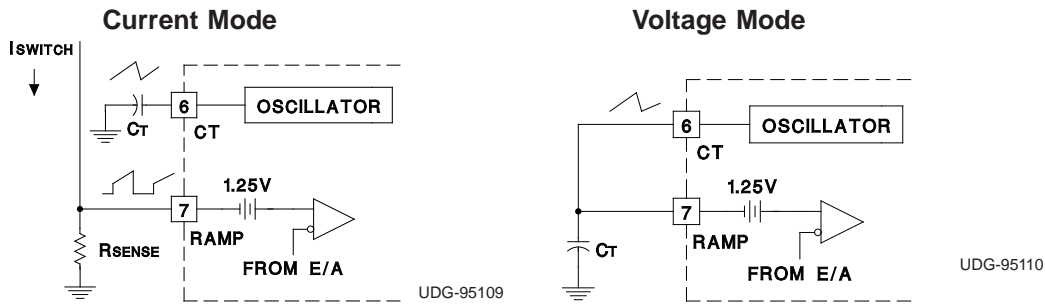

Figure 8. Control Methods

## Synchronization

The oscillator can be synchronized by an external pulse inserted in series with the timing capacitor. Program the free-running frequency of the oscillator to be 10% to 15% slower than the desired synchronous frequency. The pulse width should be greater than 10 ns and less than half the discharge time of the oscillator. The rising edge of the CLK/LEB pin can be used to generate a synchronizing pulse for other chips. Note that the CLK/LEB pin no longer accepts an incoming synchronizing signal.

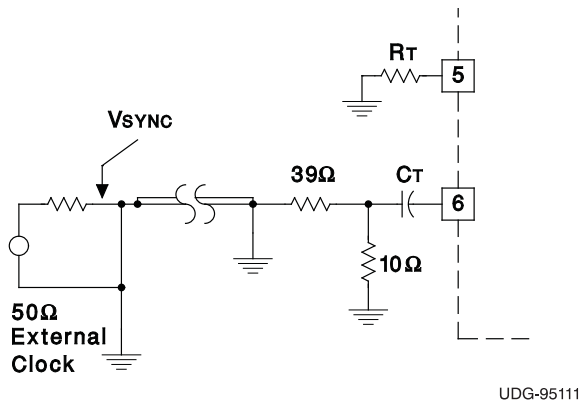

Figure 9. General Oscillator Synchronization

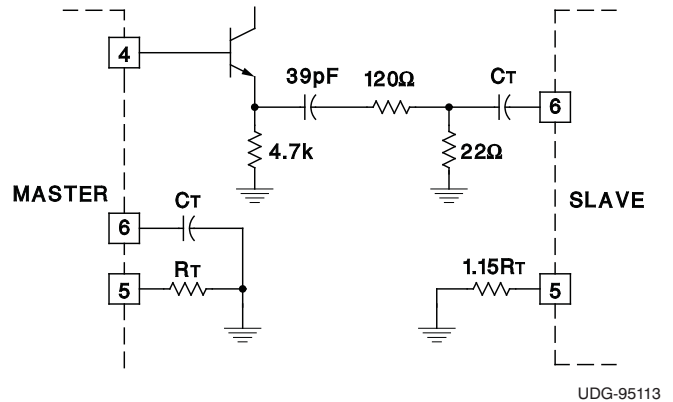
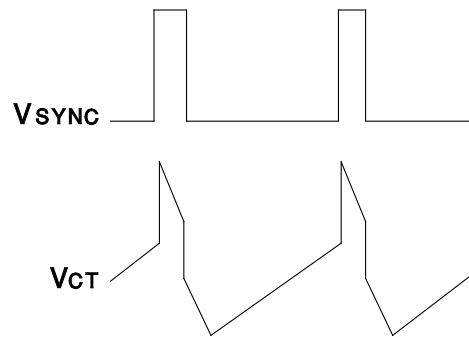

Figure 10. Two Unit Interface



UDG-95112

Figure 11. Operational Waveforms

## High-Current Outputs

Each totem pole output can deliver a 2-A peak current into a capacitive load. The output can slew a 1000-pF capacitor by 15 V in approximately 20 ns. Separate collector supply (VC) and power ground (PGND) pins help decouple the device's analog circuitry from the high-power gate drive noise. The use of 3-A Schottky diodes (1N5120, USD245, or equivalent) from each output to both VC and PGND are recommended. The diodes clamp the output swing to the supply rails, necessary with any type of inductive/capacitive load, typical of a MOSFET gate. Schottky diodes must be used because a low forward voltage drop is required. Do not use standard silicon diodes.

Although they are single-ended devices, two output drivers are available on the UC2825A. These can be paralleled by the use of a 0.5- $\Omega$  (noninductive) resistor connected in series with each output for a combined peak current of 4 A.

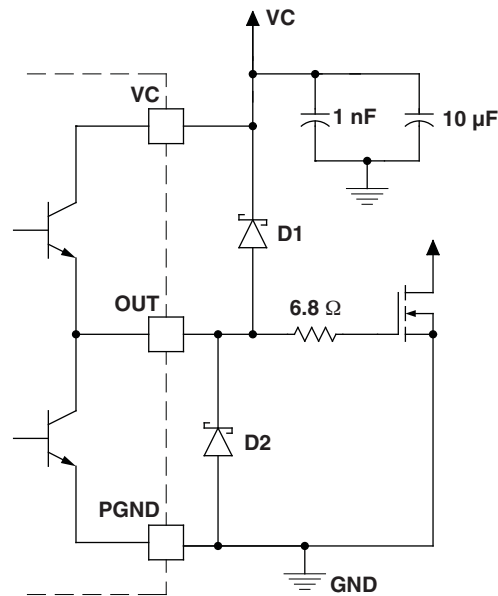

D1, D2 = 1N5820

**Figure 12. Power MOSFET Drive Circuit**

## Ground Planes

Each output driver of these devices is capable of 2-A peak currents. Careful layout is essential for correct operation of the chip. A ground plane must be employed. A unique section of the ground plane must be designated for high di/dt currents associated with the output stages. This point is the power ground to which the PGND pin is connected. Power ground can be separated from the rest of the ground plane and connected at a single point, although this is not necessary if the high di/dt paths are well understood and accounted for. VCC should be bypassed directly to power ground with a good high-frequency capacitor. The sources of the power MOSFET should connect to power ground, as should the return connection for input power to the system and the bulk input capacitor. The output should be clamped with a high-current Schottky diode to both VCC and PGND. Nothing else should be connected to power ground.

VREF should be bypassed directly to the signal portion of the ground plane with a good high-frequency capacitor. Low ESR/ESL ceramic 1-mF capacitors are recommended for both VCC and VREF. All analog circuitry should, likewise, be bypassed to the signal ground plane.

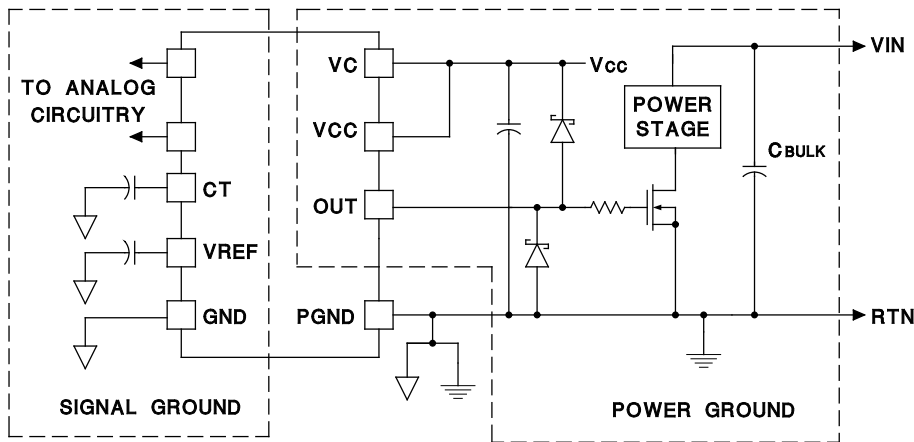

UDG-95115

Figure 13. Ground Planes Diagram

### Open-Loop Test Circuit

This test fixture is useful for exercising many functions of this device family and measuring their specifications. As with any wideband circuit, careful grounding and bypass procedures should be followed. The use of a ground plane is highly recommended.

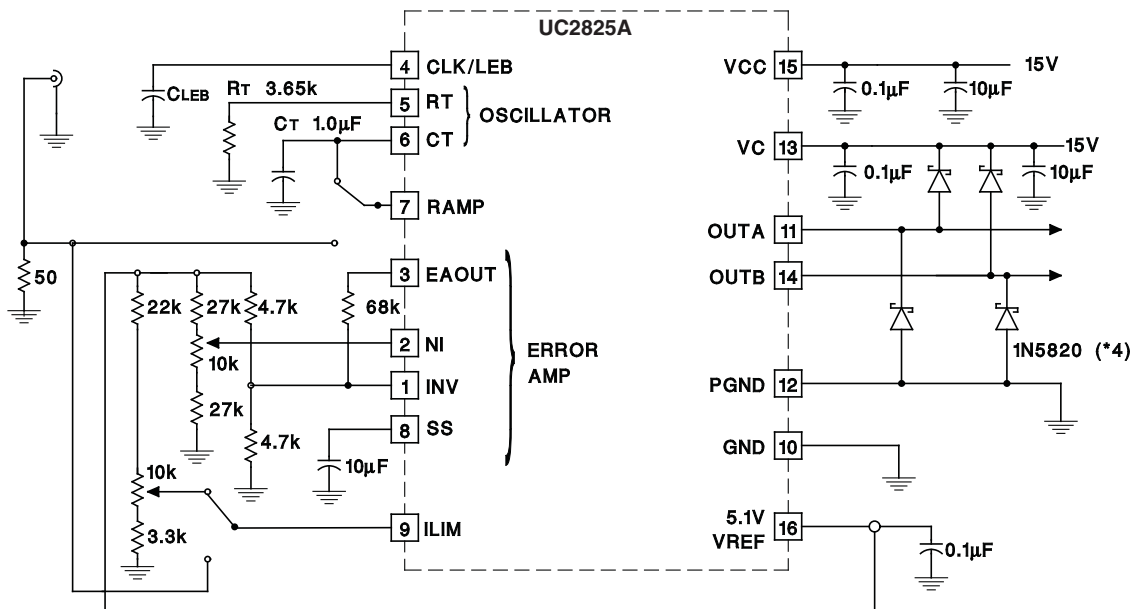

Figure 14. Open-Loop Test Circuit Schematic

**PACKAGING INFORMATION**

Orderable part number	Status (1)	Material type (2)	Package   Pins	Package qty   Carrier	RoHS (3)	Lead finish/ Ball material (4)	MSL rating/ Peak reflow (5)	Op temp (°C)	Part marking (6)
<a href="#">UC2825AQDWRQ1</a>	NRND	Production	SOIC (DW)   16	2000   LARGE T&R	Yes	NIPDAU	Level-2-260C-1 YEAR	-40 to 125	UC2825AQDW
UC2825AQDWRQ1.A	NRND	Production	SOIC (DW)   16	2000   LARGE T&R	Yes	NIPDAU	Level-2-260C-1 YEAR	-40 to 125	UC2825AQDW

(1) **Status:** For more details on status, see our [product life cycle](#).

(2) **Material type:** When designated, preproduction parts are prototypes/experimental devices, and are not yet approved or released for full production. Testing and final process, including without limitation quality assurance, reliability performance testing, and/or process qualification, may not yet be complete, and this item is subject to further changes or possible discontinuation. If available for ordering, purchases will be subject to an additional waiver at checkout, and are intended for early internal evaluation purposes only. These items are sold without warranties of any kind.

(3) **RoHS values:** Yes, No, RoHS Exempt. See the [TI RoHS Statement](#) for additional information and value definition.

(4) **Lead finish/Ball material:** Parts may have multiple material finish options. Finish options are separated by a vertical ruled line. Lead finish/Ball material values may wrap to two lines if the finish value exceeds the maximum column width.

(5) **MSL rating/Peak reflow:** The moisture sensitivity level ratings and peak solder (reflow) temperatures. In the event that a part has multiple moisture sensitivity ratings, only the lowest level per JEDEC standards is shown. Refer to the shipping label for the actual reflow temperature that will be used to mount the part to the printed circuit board.

(6) **Part marking:** There may be an additional marking, which relates to the logo, the lot trace code information, or the environmental category of the part.

Multiple part markings will be inside parentheses. Only one part marking contained in parentheses and separated by a "-" will appear on a part. If a line is indented then it is a continuation of the previous line and the two combined represent the entire part marking for that device.

**Important Information and Disclaimer:**The information provided on this page represents TI's knowledge and belief as of the date that it is provided. TI bases its knowledge and belief on information provided by third parties, and makes no representation or warranty as to the accuracy of such information. Efforts are underway to better integrate information from third parties. TI has taken and continues to take reasonable steps to provide representative and accurate information but may not have conducted destructive testing or chemical analysis on incoming materials and chemicals. TI and TI suppliers consider certain information to be proprietary, and thus CAS numbers and other limited information may not be available for release.

In no event shall TI's liability arising out of such information exceed the total purchase price of the TI part(s) at issue in this document sold by TI to Customer on an annual basis.

**OTHER QUALIFIED VERSIONS OF UC2825A-Q1 :**

- Catalog : [UC2825A](#)

- Enhanced Product : [UC2825A-EP](#)

NOTE: Qualified Version Definitions:

- Catalog - TI's standard catalog product
- Enhanced Product - Supports Defense, Aerospace and Medical Applications

**TAPE AND REEL INFORMATION**

**QUADRANT ASSIGNMENTS FOR PIN 1 ORIENTATION IN TAPE**

\*All dimensions are nominal

Device	Package Type	Package Drawing	Pins	SPQ	Reel Diameter (mm)	Reel Width W1 (mm)	A0 (mm)	B0 (mm)	K0 (mm)	P1 (mm)	W (mm)	Pin1 Quadrant
UC2825AQDWRQ1	SOIC	DW	16	2000	330.0	16.4	10.75	10.7	2.7	12.0	16.0	Q1

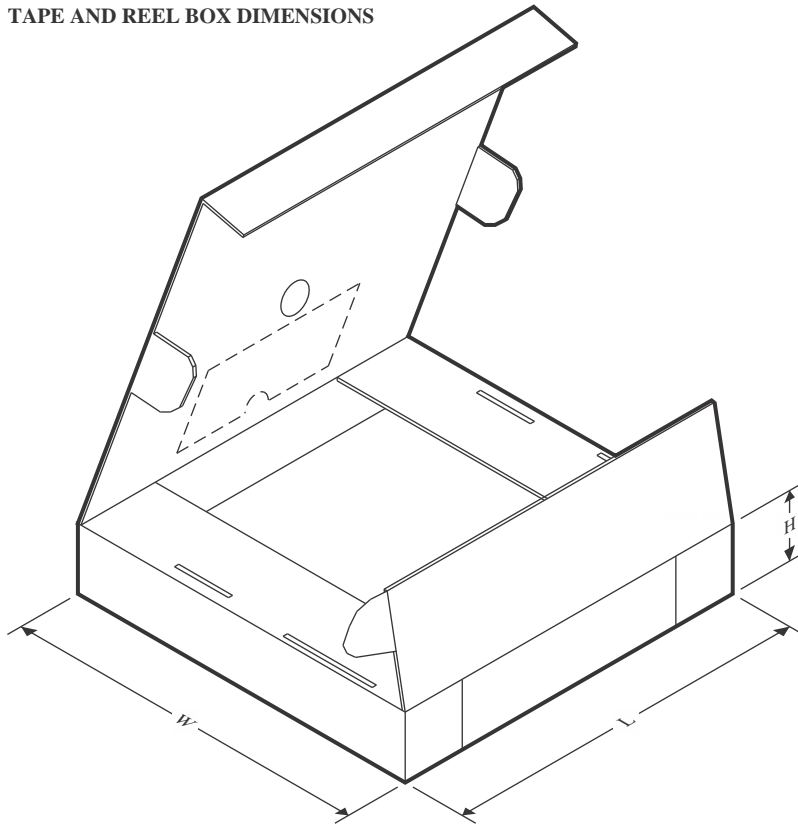
**TAPE AND REEL BOX DIMENSIONS**

\*All dimensions are nominal

Device	Package Type	Package Drawing	Pins	SPQ	Length (mm)	Width (mm)	Height (mm)
UC2825AQDWRQ1	SOIC	DW	16	2000	353.0	353.0	32.0

## GENERIC PACKAGE VIEW

**DW 16**

**SOIC - 2.65 mm max height**

7.5 x 10.3, 1.27 mm pitch

SMALL OUTLINE INTEGRATED CIRCUIT

This image is a representation of the package family, actual package may vary.  
Refer to the product data sheet for package details.

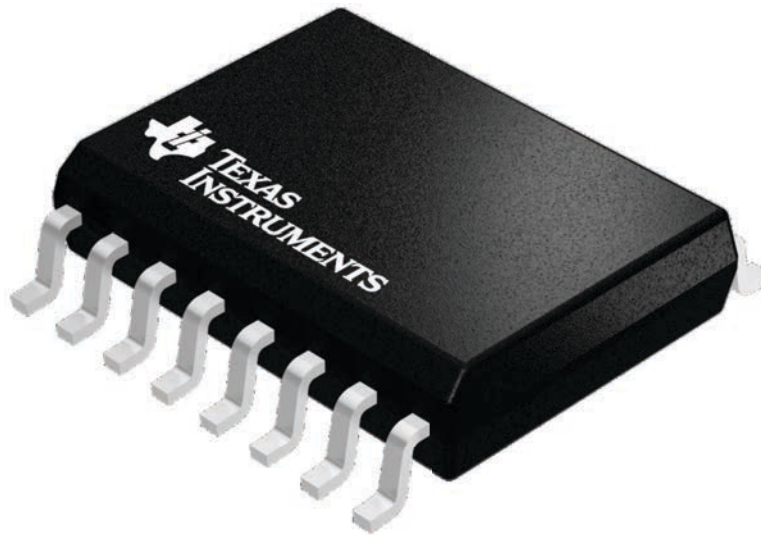

4224780/A

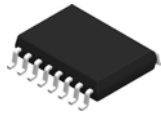

DW0016A

# PACKAGE OUTLINE

SOIC - 2.65 mm max height

SOIC

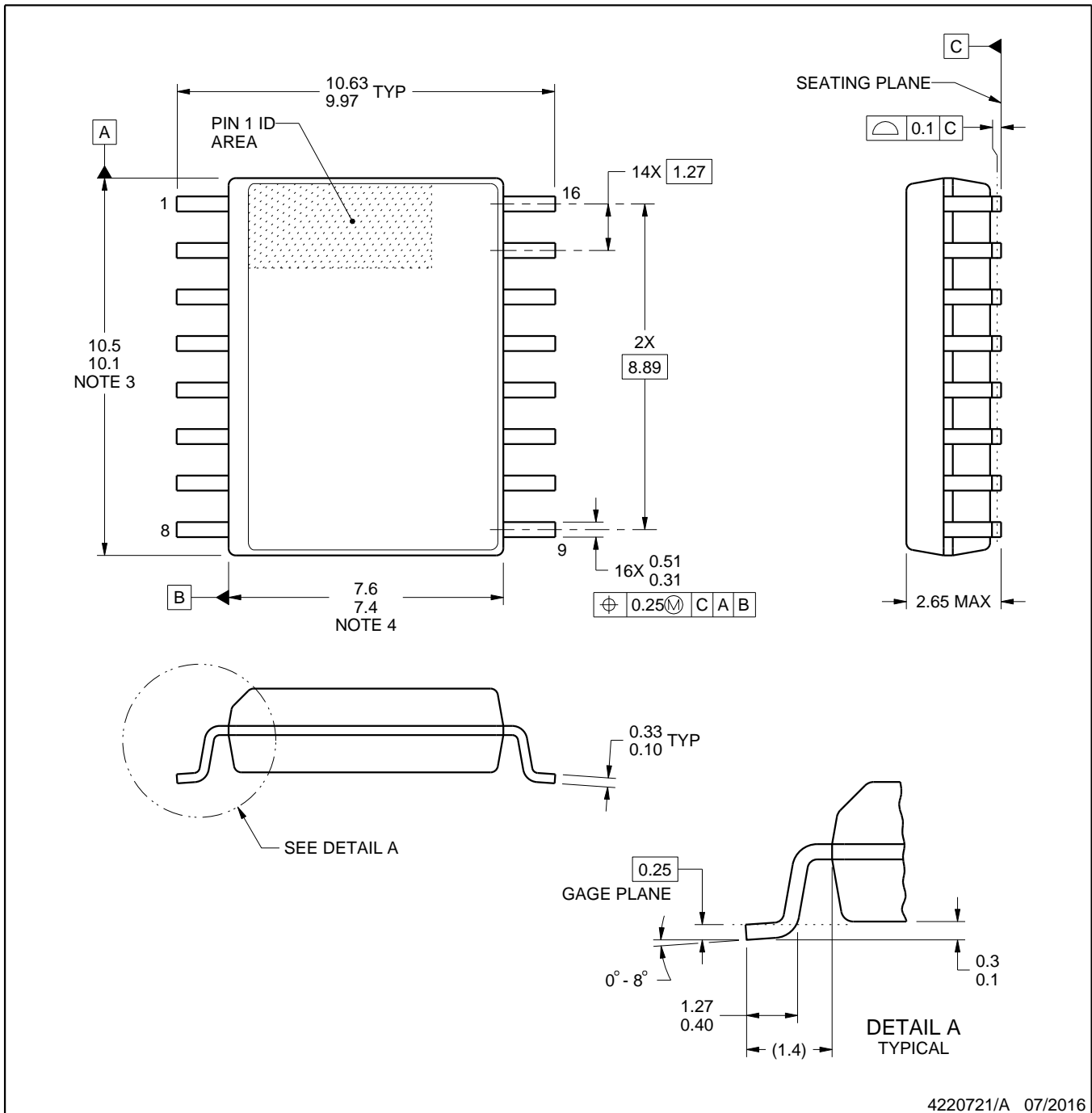

4220721/A 07/2016

NOTES:

1. All linear dimensions are in millimeters. Dimensions in parenthesis are for reference only. Dimensioning and tolerancing per ASME Y14.5M.
2. This drawing is subject to change without notice.
3. This dimension does not include mold flash, protrusions, or gate burrs. Mold flash, protrusions, or gate burrs shall not exceed 0.15 mm, per side.
4. This dimension does not include interlead flash. Interlead flash shall not exceed 0.25 mm, per side.
5. Reference JEDEC registration MS-013.

# EXAMPLE BOARD LAYOUT

DW0016A

SOIC - 2.65 mm max height

SOIC

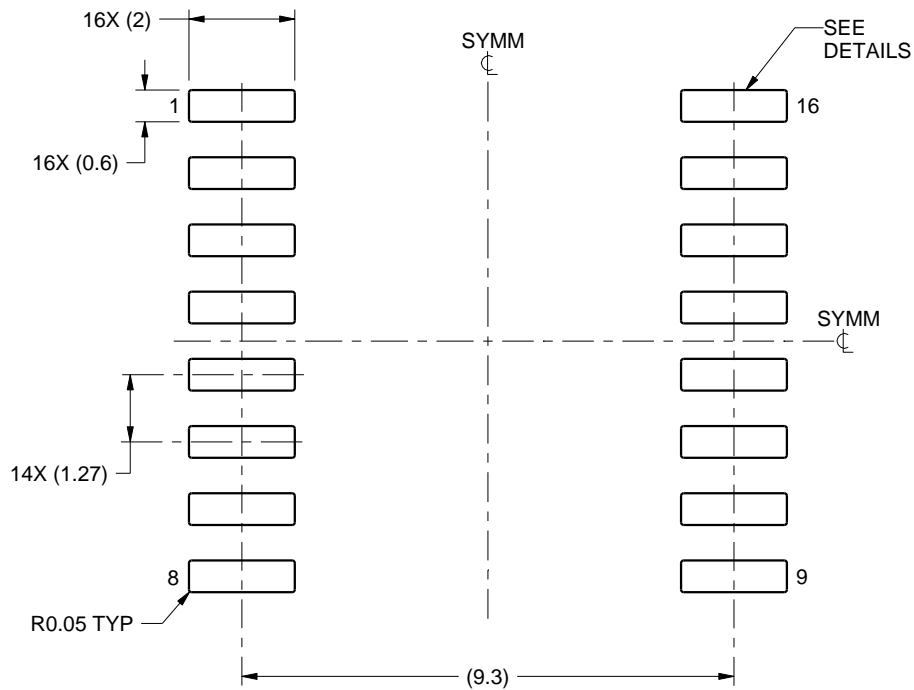

LAND PATTERN EXAMPLE  
SCALE:7X

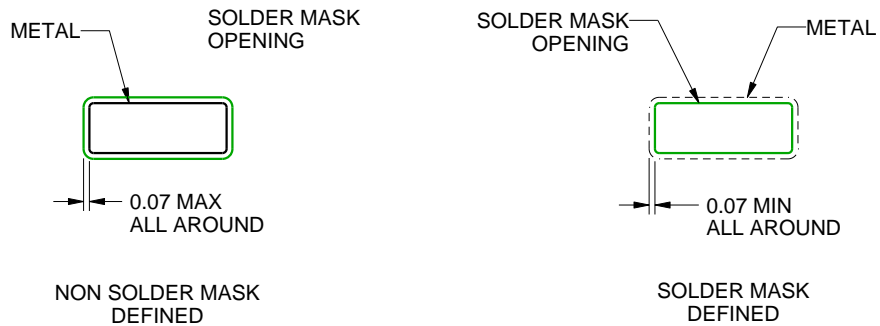

SOLDER MASK DETAILS

4220721/A 07/2016

NOTES: (continued)

6. Publication IPC-7351 may have alternate designs.

7. Solder mask tolerances between and around signal pads can vary based on board fabrication site.

# EXAMPLE STENCIL DESIGN

DW0016A

SOIC - 2.65 mm max height

SOIC

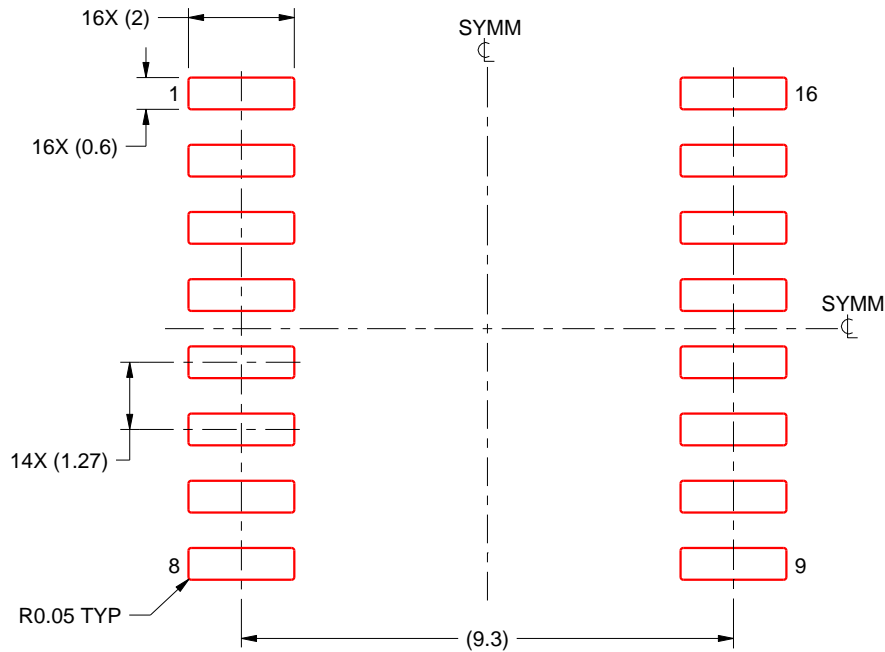

SOLDER PASTE EXAMPLE  
BASED ON 0.125 mm THICK STENCIL  
SCALE:7X

4220721/A 07/2016

NOTES: (continued)

8. Laser cutting apertures with trapezoidal walls and rounded corners may offer better paste release. IPC-7525 may have alternate design recommendations.
9. Board assembly site may have different recommendations for stencil design.

## IMPORTANT NOTICE AND DISCLAIMER

TI PROVIDES TECHNICAL AND RELIABILITY DATA (INCLUDING DATASHEETS), DESIGN RESOURCES (INCLUDING REFERENCE DESIGNS), APPLICATION OR OTHER DESIGN ADVICE, WEB TOOLS, SAFETY INFORMATION, AND OTHER RESOURCES "AS IS" AND WITH ALL FAULTS, AND DISCLAIMS ALL WARRANTIES, EXPRESS AND IMPLIED, INCLUDING WITHOUT LIMITATION ANY IMPLIED WARRANTIES OF MERCHANTABILITY, FITNESS FOR A PARTICULAR PURPOSE OR NON-INFRINGEMENT OF THIRD PARTY INTELLECTUAL PROPERTY RIGHTS.

These resources are intended for skilled developers designing with TI products. You are solely responsible for (1) selecting the appropriate TI products for your application, (2) designing, validating and testing your application, and (3) ensuring your application meets applicable standards, and any other safety, security, regulatory or other requirements.

These resources are subject to change without notice. TI grants you permission to use these resources only for development of an application that uses the TI products described in the resource. Other reproduction and display of these resources is prohibited. No license is granted to any other TI intellectual property right or to any third party intellectual property right. TI disclaims responsibility for, and you fully indemnify TI and its representatives against any claims, damages, costs, losses, and liabilities arising out of your use of these resources.

TI's products are provided subject to [TI's Terms of Sale](#), [TI's General Quality Guidelines](#), or other applicable terms available either on [ti.com](http://ti.com) or provided in conjunction with such TI products. TI's provision of these resources does not expand or otherwise alter TI's applicable warranties or warranty disclaimers for TI products. Unless TI explicitly designates a product as custom or customer-specified, TI products are standard, catalog, general purpose devices.

TI objects to and rejects any additional or different terms you may propose.

Copyright © 2026, Texas Instruments Incorporated

Last updated 10/2025